

DRAFT PROOF 2018

A collection of ideas, processes and projects
Interior Architecture & Design Middlesex University

¹ draft

verb \ 'draft , 'dräft \

To draft; draw up various iterations, not a final copy.

2	draft four
3	preface
4	introduction
4	highlights + collaborations
8	BA (Hons) Interior Architecture
	year one
	a sense of place
	a place for identity
14	year two
	new learning landscapes
	people's palace: new foyer
24	year three
	the people's palace 1
	writing portfolio
	the people's palace 2
44	BA (Hons) Interior Design
	year one
	a sense of place
	a place for identity
50	year two
	poetry pavilion
	melting point
60	year three
	designing for our future selves 1
	research project
	designing for our future selves 2
80	MA Interiors
	in-betweeness
90	interior architecture + design
	highlights + collaborations
	spatial cultures
	structure & balance
	hammeron competition
	virtual reality: digital showscapes
	HKU space
	building a design community
	A&E
	acknowledgements

Middlesex University, London, was formed in 1992 and grew out of an amalgam of much older institutions including the influential Hornsey School of Art. So the graduating students represented in this magazine come from a venerable lineage of interior designers and interior architects trained at Middlesex who have played significant roles in shaping the interiors industry in London and globally over many decades. Situated in the Faculty of Arts and Creative Industries, the Interiors students (together with students of craft and jewellery in the Interiors Directorate) make up roughly half of the Design Department, alongside those studying fashion.

At Middlesex we believe all design practices should be outward facing, inclusive, imaginative and dynamic: we train designers who can address real world situations face on but who are eager to challenge the status quo. That is why we do not have a Middlesex 'house style': instead, we value self-expression, independent minds and genuinely innovative ideas. But our talented and skilful teaching and technical team also go to great lengths to introduce students to the realities of professional life in the interiors industry, in order to best equip them for their future careers. This year I am particularly pleased with student success at the Hammerson sponsored competition on the Future of Retail.

This spring saw the culmination of 'Digital Showscapes' a two-year project funded by the HEFCE Catalyst Fund for Innovations in Learning and Teaching. Our Interior Design programme has pioneered the use of Virtual Reality technology as a tool for students to present their speculative projects in a new, immersive way. It is emblematic of how we embrace new ways of working that enhance our graduates' skills and employability.

The first cohort of students began our new 3D Design Foundation Year in October 2017 and most of them will progress onto BA Interior Architecture or BA Interior Design next academic year. And MA Interiors has its largest cohort yet, as it grows its reputation nationally and internationally with students from as far afield as Japan, Malaysia, Iran, Romania and Dominican Republic. As we respond to both the challenges of the design industry and the fluctuations of higher education, I expect we will retain a distinctive mix of idealism for the positive change design can bring to the world, together with a realistic view of how to make those changes possible, that are the hallmarks of design at Middlesex University.

Professor Gareth Williams

Head of the Design Department

Draft Four, as with previous iterations, aims to highlight the breadth of student design activity and achievement on our Interior programmes during the academic year. 2017/18 commenced following one of our most successful years. At the annual Interior Educators Exhibition in London, a show that represents graduate work nationwide, BA Interior Architecture student, Lauren Slevin, won the Best Overall Student Project Award, an excellent achievement. Second year students, in a course competition, designed our exhibition at Interior Educators and so we were also particularly delighted to pick up an award for Best Exhibition of Student Work. We believe that this success relates to the strong links that we have and continue to build with practice and industry. This year we have developed these connections in a number of ways, illustrated in this issue.

Interior Architecture sustains its focus on the exploration of old buildings as palimpsests and their adaptation in the remodeling process. Alexandra Palace in North London was the site for this year's study and third year students were invited to propose ideas for the reinvention of the East Wing. This huge complex of spaces has a fascinating backstory, and includes the abandoned BBC Television Studios and (currently being refurbished) Victorian Theatre.

Third Year Interior Design students investigated the commercial relationship between sensory perception, ageing and well being. The year-long study involved an initial brief to design a retail outlet that specifically explored one of the five senses and a major project that expanded the research into sensory experience of place through the design of related larger scale typologies.

Following on from the success last year in the Retail Student Design Awards, second year students from both Interior BAs this year worked on a joint project called the Future of Retail. The brief evolved from a competition theme set in collaboration between Middlesex University and developer Hammerson Plc. The project's focus was on responsible retail linked to charitable organisations and Claire Robey won a Best Project award and an internship with Hammerson for her innovative idea to retail 3D printed spectacles utilizing hemp based filament.

By nature, designing interiors is a collaborative and interdisciplinary practice and our programmes are committed to developing and expanding our collaborative community. Interior students were involved in a cross faculty project called A+E, an abbreviation for both Accident and Emergency and Arts and Education. The project invited students across a range of subjects as diverse as acting,

nursing and fine art, to work together and creatively respond to the current state of the National Health Service. The outcomes were fascinating, provocative and in some cases controversial.

The beginning of the academic year saw further extension of our learning timeframe with the introduction of a new 3D Foundation Year that allows applicants to our degrees the option to build basic knowledge of three-dimensional design at Middlesex, prior to progressing onto one of the degree programmes. At the other end of the learning spectrum, our MA Interiors (Architecture + Design) continues to grow and develop its unique approach to postgraduate study. Challenging and redefining what constitutes the 'interior', the programme places emphasis on processing design ideas through making and the compilation of three books of analysis. Individual expression is nurtured through focus on the articulation of in-between spaces, from the room to the city, into a diverse array of places with a social conscience.

At our Degree Show this year, in addition to the conventional format of presenting student work, we are showing a selection of projects using virtual reality technology. The project, entitled Digital Showscapes, exemplifies our commitment to offer students the broadest range of opportunities to develop and represent their design proposals. It also endorses that the emphasis we place on exploring design possibilities through making physical models does not negate or oppose the need to develop skills using the latest digital technologies. We acknowledge analogue and digital forms of investigation and representation with equal merit in the design process - as with theory and practice, the real and the speculative or the look and the feel. By embedding this understanding within our pedagogy, we aim to equip our graduates with the appropriate knowledge and skills to eventually lead and inform professional practice rather than to merely follow it.

I would like to thank our teaching team for their sustained dedication and excellent contribution to the programmes again this year. In particular, congratulations to MA Programme Leader, Jason Scoot and 3D Foundation Year Leader, Beverley Speight, who were shortlisted for teaching awards. Our thanks and very best wishes are also extended to former Director of Programmes Tony Side, who retired this year, after 25 years of invaluable commitment to our programmes.

And of course, congratulations to all of our graduating students. We wish you all the very best for your onward journey and future success.

David Fern

Director of Programmes for Interior Architecture and Design

— 2017-18

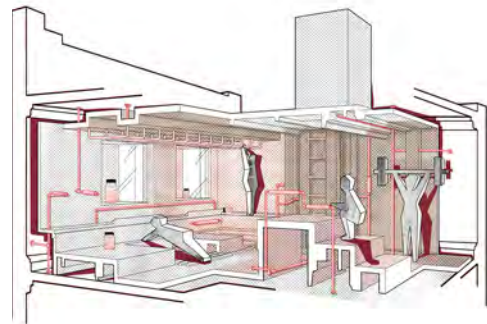

Interior Educators 2017

We had great success at the 2017 Interior Educators Exhibition held at the Truman Brewery, with twenty students exhibiting their work on behalf of our Interior Architecture & Design courses.

Last year, Interior Architecture graduate, Lauren Slevin, won 1st Place for Best Overall Student Project (above). Lauren's project focused on issues of consumption, detoxification and well-being in the soon-to-be remodelled location of Smithfield Market, Farringdon, London. Middlesex University also won the Best Stand – an award that recognizes the standard of student cohort work shown using the most appropriate construction form for display of 2D/3D & supporting work.

Interior Educators is an organisation established by academics representing well-established Interior programmes from across the UK and now represents more than 50 Higher Education institutions teaching almost 3,000 students.

Visit the Interior Educators website to see more:
www.interioreducators.co.uk/student-awards-2017



What will the shopping centre of the future look like?

Middlesex students were invited to participate in a competition held in partnership by Middlesex University & Hammerson Plc, a major owner, manager and developer of retail destinations across Europe. Participants were asked to pitch ideas from a variety of areas focused on future retail innovations. Four of our students made it to the final stage of the competition with outstanding design proposals. Claire Robey, second year Interior Architecture student won 1st place prize for her design of a retail store selling bespoke 3D printed spectacles produced using hemp filament. She will be completing an internship at Hammerson Plc this summer. (Above)

Turn to page 95 to see Claire Robey's winning project.



A&E Collaboration Project Accident & Emergency/Arts & Education

Interior Architecture & Design students took part in the 'A&E' collaboration project; a student engagement project that opened up learning dialogues between students from different disciplines at different stages of their learning journeys. It challenged students to work in studios outside their normal habitat and engage in specialist support in new multidisciplinary learning communities. It brought together many Faculty of Arts & Creative Industry departments and some from outside of the faculty (Nursing, Education, and LSS) as well as external agencies such as the Red Cross.

The A&E project went on to receive a nomination for 'Collaboration of the Year' at the Middlesex 2018 Staff Awards.

Turn to page 102 to see more details.



BA Study Trip Antwerp

Interior Architecture and Interior Design 1st year students travelled to Antwerp, Belgium in November 2017 for a combined study trip. Philippe Swartenbroux, a lecturer from Hasselt University, met us from the train and introduced us to the historical and contemporary context of the city. As with all study trips, staff and students were able to spend a more relaxed social time together while enjoying numerous sights of cultural interest, including the MAS Museum, Rubens's House, The Museum of Contemporary Art (above) and the recently completed Zaha Hadid Port House.



Placement Story Daniela Hurmuzache

'Working at FITCH definitely has its perks.. the social and cultural aspects of the company are great. Even just working / collaborating on the same projects with others made me want to discover and explore design more than ever. Throughout my year I've had the opportunity to be part of a strong collective and to get involved in so many exciting activities I'd never even dreamt of. Getting immersed into the FITCH culture was without doubt the best learning experience, and activities like Bold Day, 5.15 and staff parties made my year so much more exciting, although within a serious work environment. Considering that FITCH's approach is to design the future and make it memorable, I can wholeheartedly say that they've succeeded in making my placement unforgettable'.

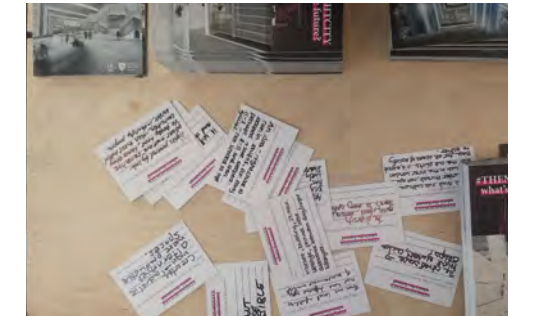

MDX Strategy Launch

In October Middlesex University launched its new strategy at London's iconic City Hall - the strategy closely aligns with a number of governmental agendas including supporting social mobility and upskilling the country's workforce. To enforce the role of Middlesex as a key London player, and to underline the connection between Middlesex activities and the current city policies, a few projects were showcased at the launch event.

#Nightclubbing/What's the future?, a series of projects developed across Interior Architecture courses last year, questions the role of the Night Economy, recently investigated and widely discussed. *What are the qualities of London's night life? Which activities, actions and performances are part of London's night life? And - What will London's night life spaces be like in 10 years?*, were some of the questions answered by the attendees during the event, in a lively debate with our students.

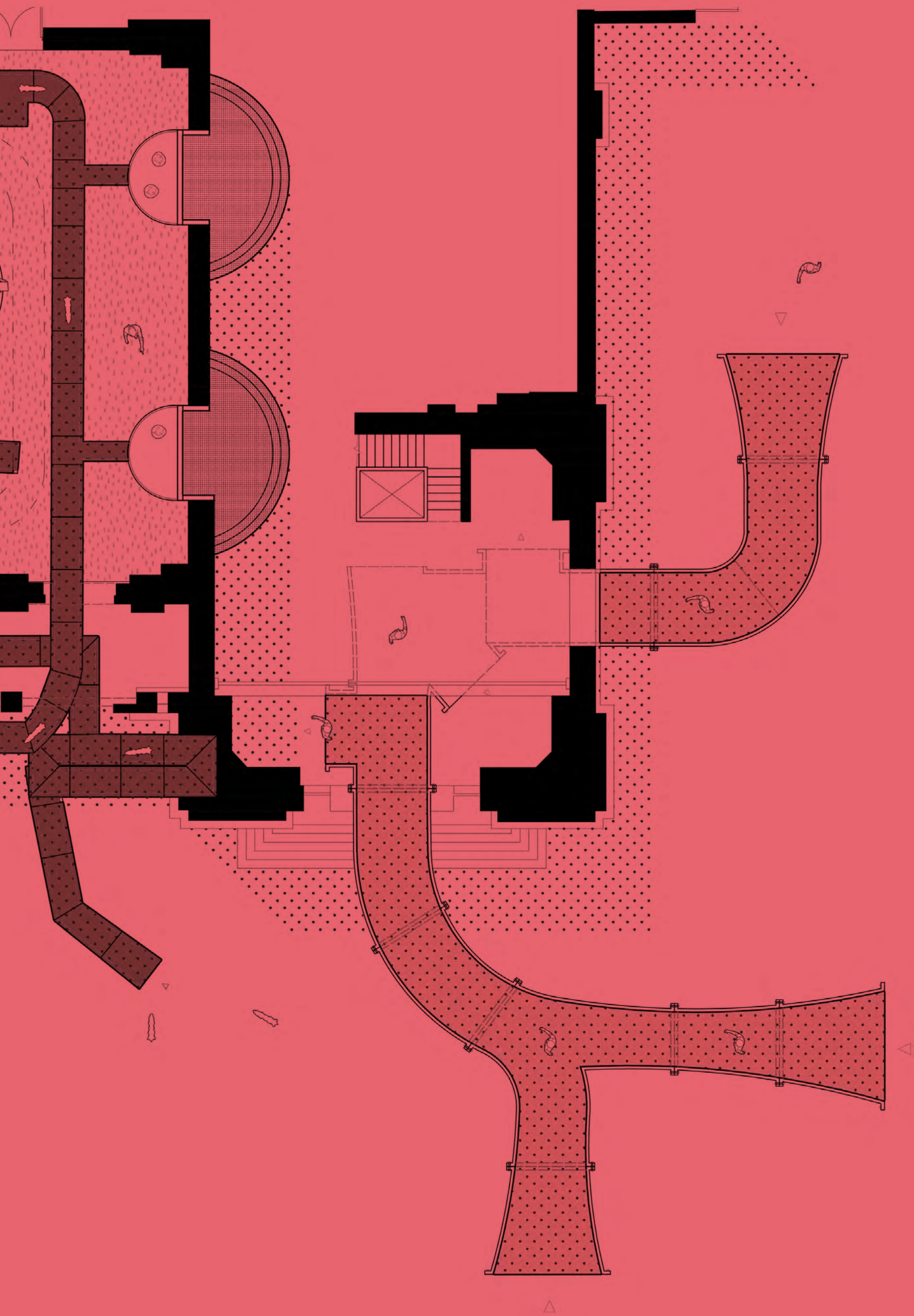

BA (Hons) Interior Architecture is concerned with the study of interiors that adapt and remodel interiors through architectural intervention, by respecting and connecting with existing site contexts for long term use. Projects focus on the relationship between the new design and the existing building.

BA (Hons) Interior Architecture

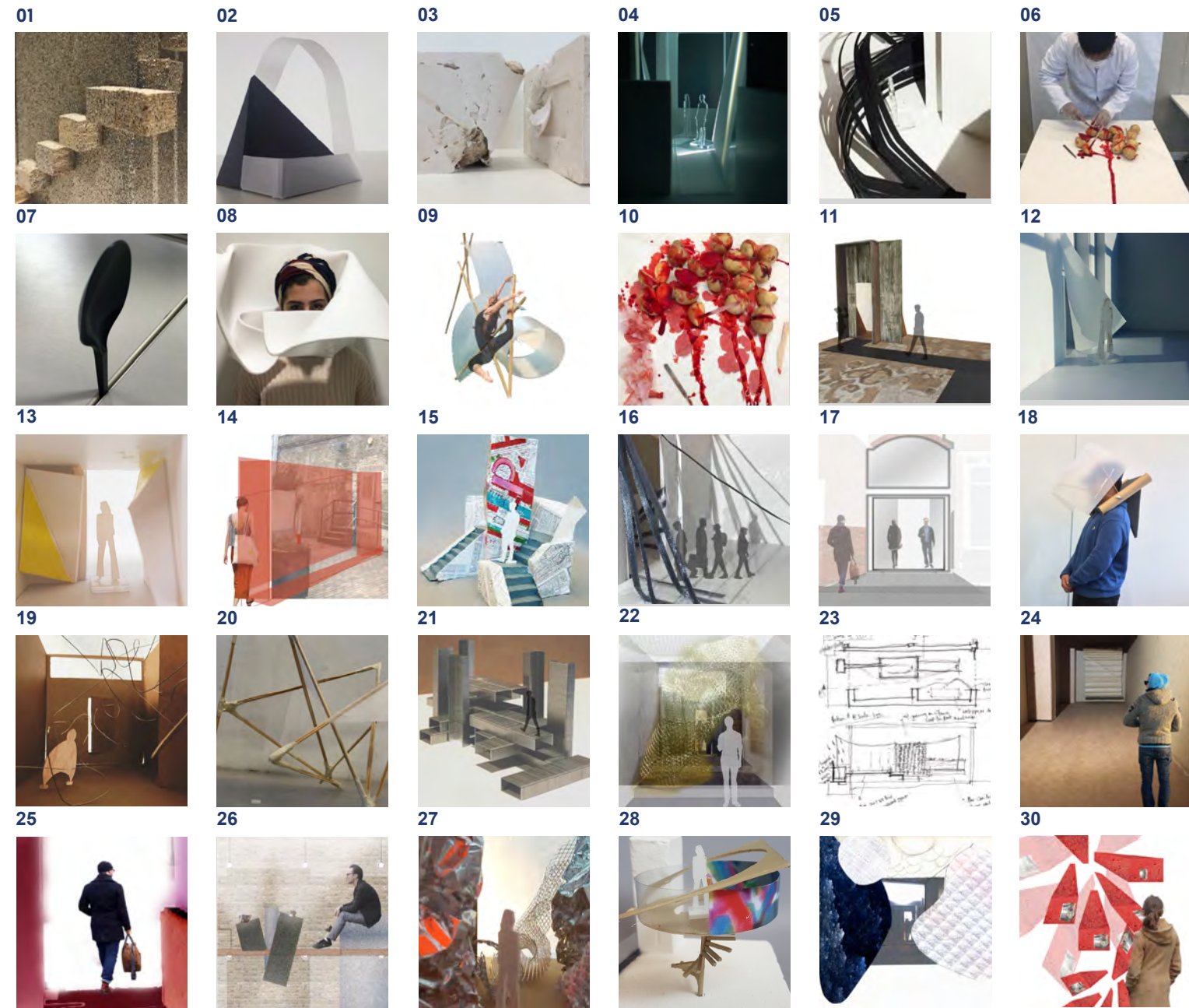

- 01 Charlie Hoar
- 02 Phinolla Glenn
- 03 Mahaylia Irish
- 04 Didem Gunes
- 05 Mahaylia Irish
- 06 Group Project
- 07 Jasmine Tetteh
- 08 Mahaylia Irish
- 09 Sareh Sarvar
- 10 Group Project
- 11 Charlie Hoar
- 12 Michael Bustillos Salazar
- 13 Michael Bustillos Salazar
- 14 Mahaylia Irish
- 15 Michael Bustillos Salazar

- 16 Sareh Sarvar
- 17 Michael Bustillos Salazar
- 18 Group Project
- 19 Charlie Hoar
- 20 Didem Gunes
- 21 Charlie Hoar
- 22 Viktorija Marcinkeviciute
- 23 Mahaylia Irish
- 24 Kowshikan Sivalingam
- 25 Sareh Sarvar
- 26 Viktorija Marcinkeviciute
- 27 Phinolla Glenn
- 28 Michael Bustillos Salazar
- 29 Viktorija Marcinkeviciute
- 30 Viktorija Marcinkeviciute

a sense of place

This project explores how a space transforms into a place through human occupancy and inhabitation. It focuses on everyday rituals and the way that we use, move through and interact with domestic, personal space. To fully understand a sense of place and relate to the needs of those we design for it is important to take human experience as a starting point. Students were asked to design an intimate workspace for an individual artist or maker that reflects their internalised world. Twice a year the chosen artist/maker participates in a local Open Studio scheme which requires the space to unfold and reveal their work to the general public and local community.

Students chose from the following:

food artist taxidermist horologist illustrator

This project involved looking at and understanding the physicality and emotional experience of personal space. Students investigated occupation relative to function, organisation and emotion. There was a particular focus on sensorial experience, memory and association in relation to their chosen client.

a place for identity

The chosen site for this project was the original Brunel Engine House, Rotherhithe. Students were asked to reinterpret the existing museum space by designing a contemporary exhibition that reflected and responded to the identity and ethos of a given designer/maker. It was important that the students demonstrated sensitivity and understanding of what motivates their designer/maker - who they are, what they do and why they do it. The aim of the exhibition was to reinforce the authenticity and value of the objects being displayed, with a focus on the atmosphere and character of the journey through and around the space.

Students needed to understand the historic nature of this building, acknowledging its scale, materiality and detailing. The design had to be accessible and engage with the general public, so students needed to consider the location of this building within its surrounding context.

- 01 Viktorija Marcinkeviciute
- 02 Jasmine Tetteh
- 03 Mahayla Irish
- 04 Viktorija Marcinkeviciute
- 05 Michael Bustillos Salazar

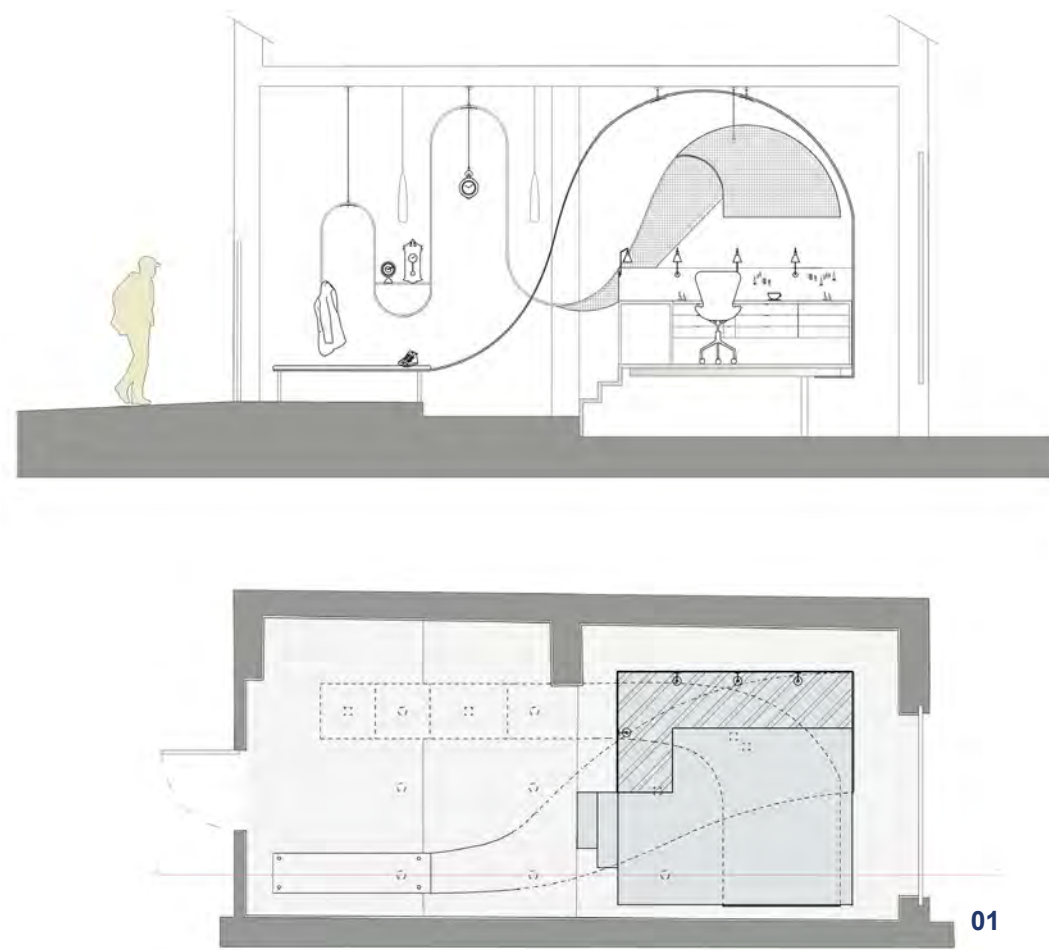

01

02



03



04



05

01



- 01 Mahaylia Irish
- 02 Jasmine Tetteh
- 03 Mahaylia Irish
- 04 Jasmine Tetteh
- 05 Viktorija Marcinkeviciute

02

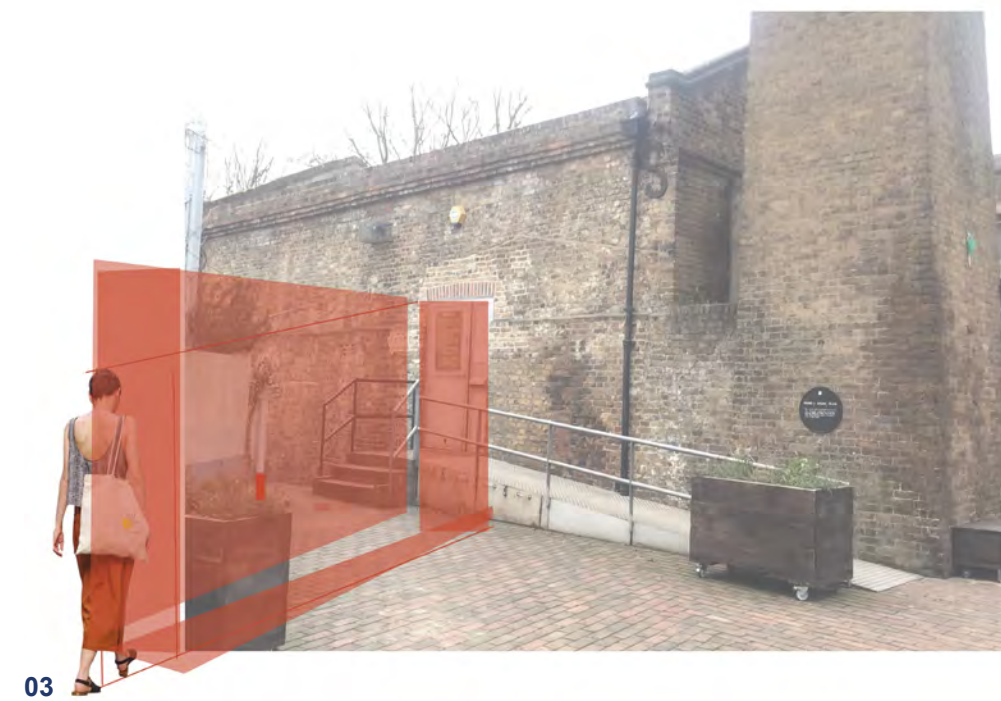

03



04

05



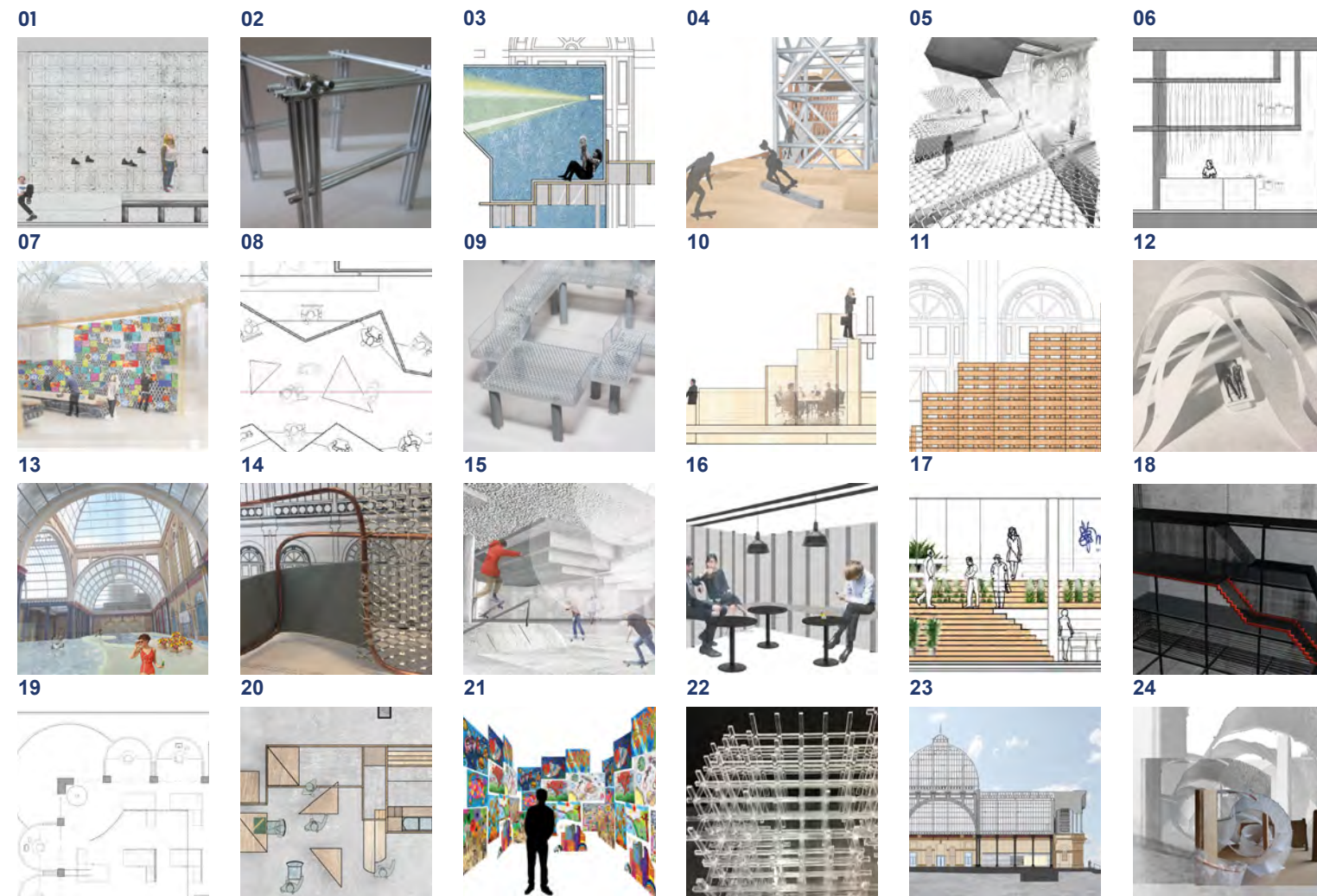

01 Anastasija Luciva
 02 Beatriz Olivera Camello
 03 Beth Williams
 04 Bish Phillips
 05 Chanel Wu
 06 Chay Clohessy
 07 Cheryse Canoville
 08 Claire Robey
 09 Daniel Brown
 10 Elena Petrova Evgenieva
 11 Evy Mansour
 12 Filuzio Soeiro Da Silva
 13 Jurate Cibulske
 14 Lucja Michalska
 15 Lucinda Hekneby

16 Marieta Correia Ca
 17 Phatsara Phueng-Ain
 18 Rehanna Cameron
 19 Rita Zavratchiyska
 20 Savanna Nelson-Murray
 21 Sylwia Chlebowicz
 22 Vanessa dos Santos Sousa
 23 Zahra Al Jbouri
 24 Michaela Ohenlen

new learning landscapes

Building on last year's Research Project - Writing Spaces¹ and on the Middlesex ongoing New Learning Landscape Project, we have involved the students in reflecting on their experience of learning and how space affects this process. Education - teaching & learning - is in continuous transformation and we need to continuously update our tools. What is the role that space has in this process? How do we articulate the relationship between learning spaces and built space? Students have undertaken fieldwork and ethnographic research to frame behaviours and needs - and to transform their studio space into a new landscape able to inspire, connect and host different users.

“Approaches to learning in educational settings are changing. Traditional teacher-centred models, where good teaching is conceptualised as the passing on of sound academic, practical or vocational knowledge/, are being replaced with student-centred approaches which emphasise the construction of knowledge through shared situations.”

¹ *Writing Spaces*, Francesca Murialdo, Ruth Bonazza and Peter Thomas, Draft Three, Middlesex University

the people's palace new foyer

In the second term of the year, second year students have been involved in the ongoing collaboration with Alexandra Palace (please refer to *The People's Palace: Narratives, Politics and Education*, page 25-27). Building on what emerged from the research and reflections carried out by their year 3 colleagues, the students worked on the idea of the New Foyer, a hybrid space that operates as a link between the two new cultural spaces in the East Wing: the Victorian Theatre (currently being renovated) and the future Learning Centre. Both spaces are due to open late in 2018, providing new content and users to the Palace, but the East Wing is a huge space and Alexandra Palace are yet to fully address its future use. The New Foyer is a social networking space with functions and activities able to develop and enforce the idea of the People's Palace.

The students worked on spaces able to welcome new users (visitor's centre); to experience the building (architectural promenade); to be entertained (pools, cinemas, performing spaces and skate parks) and to engage in workshop activities. Each project also contains a retail space - either a café, a bar, a cake shop or a souvenir shop.

The proposals are strong statements that work with the immense proportions of the East Wing, and set a series of strategies of intervention that are responsive to new inhabitations and behaviours.

² Harrison A., Cairns A., *The changing academic workplace*, DEGW, UK.



01



02



06

- 01 Marieta Correia
- 02 Marieta Correia
- 03 Lucinda Hekneby
- 04 Evy Mansour
- 05 Daniel Brown
- 06 Anastasija Luciva
- 07 Bethany Williams
- 08 Savanna Nelson-Murray

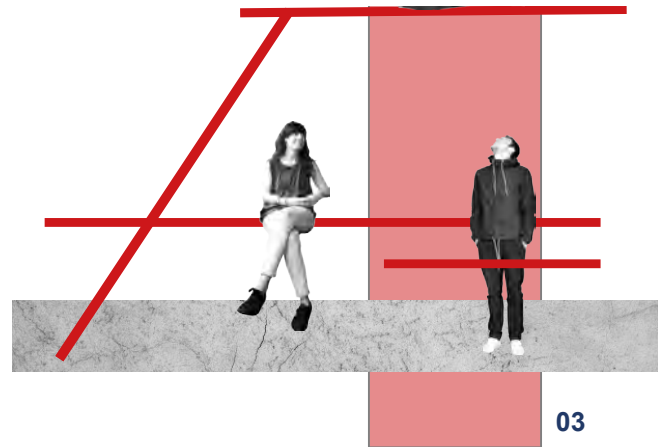

03

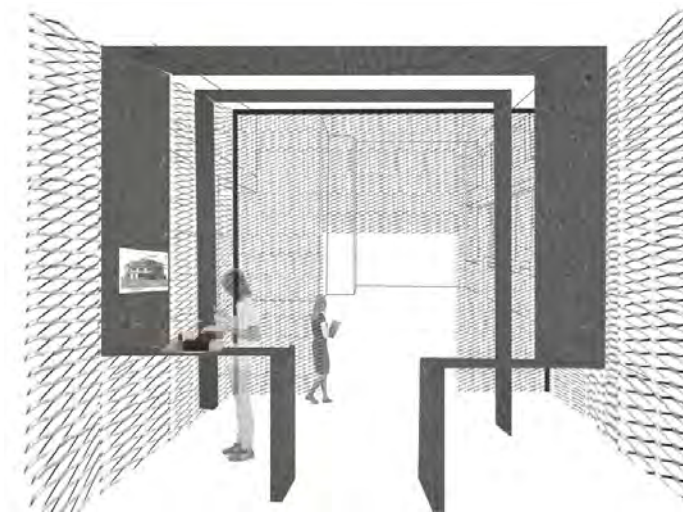

04



07

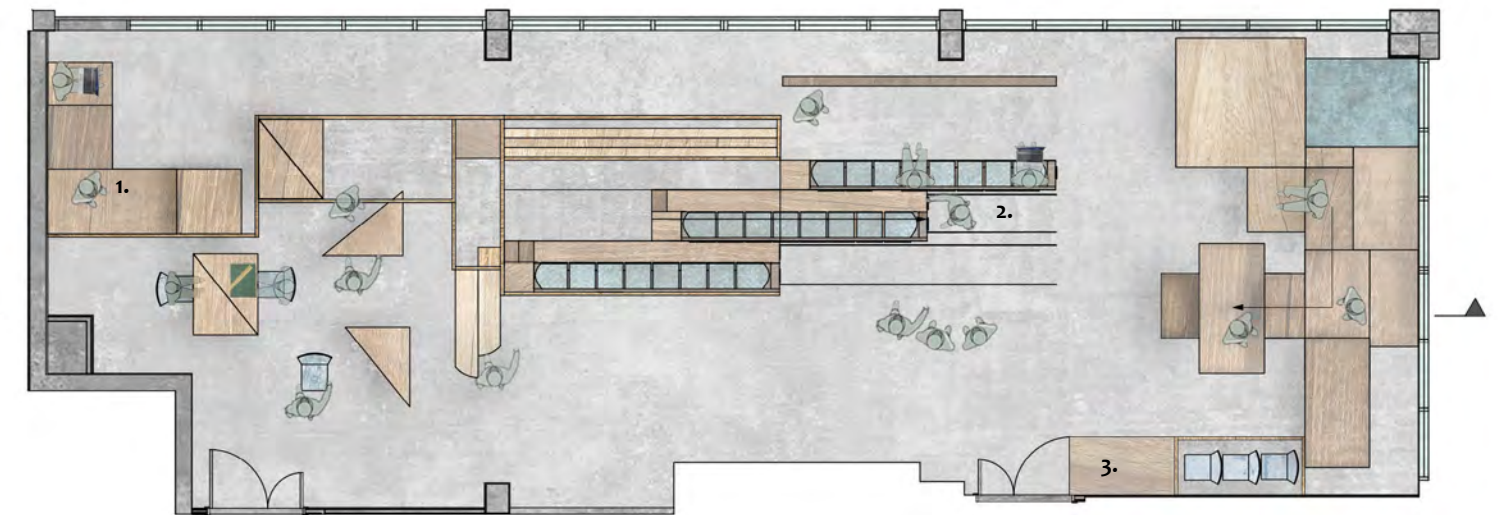

05

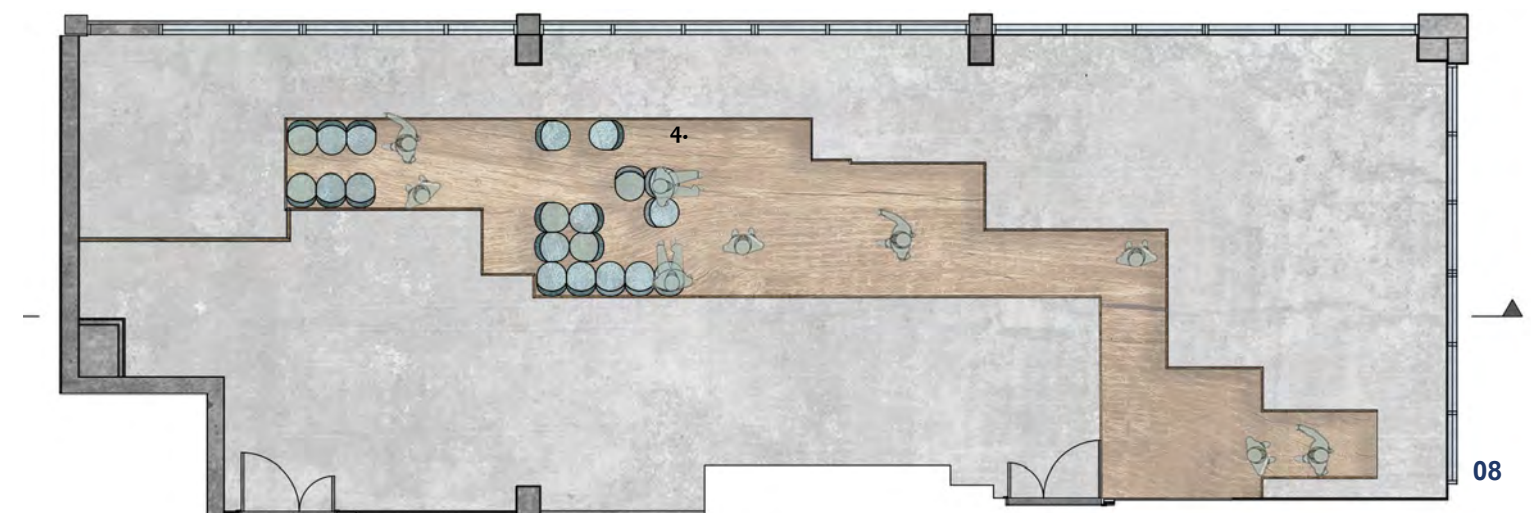

08

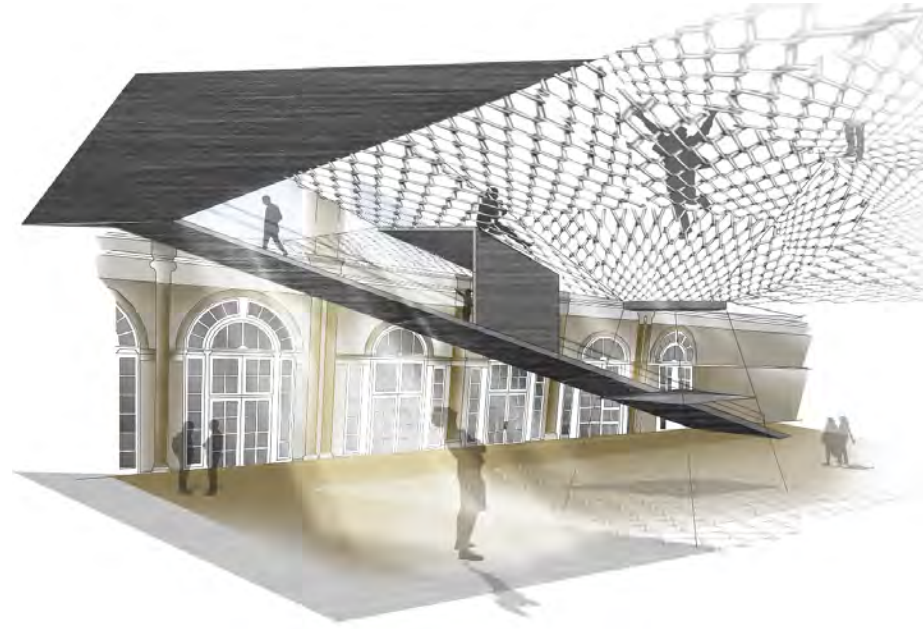

01



02

- 01 Chanel Wu
- 02 Bethany Williams
- 03 Evy Mansour
- 04 Claire Robey
- 05 Chay Clohessy
- 06 Chay Clohessy
- 07 Lucja Michalska

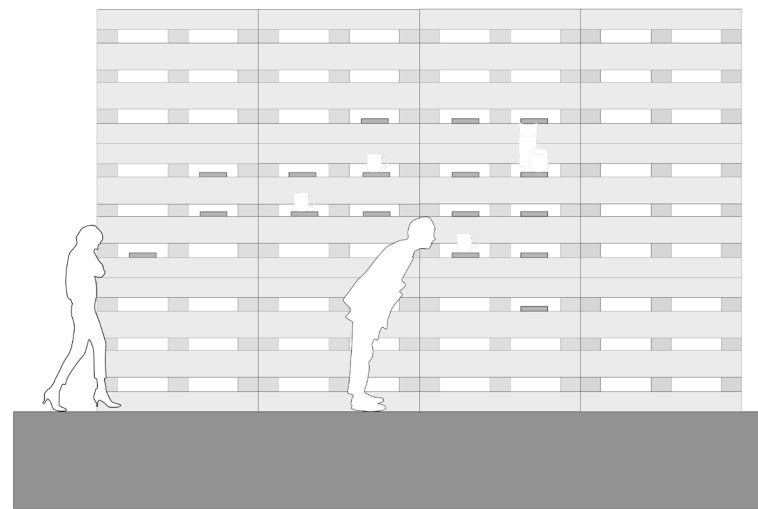

03

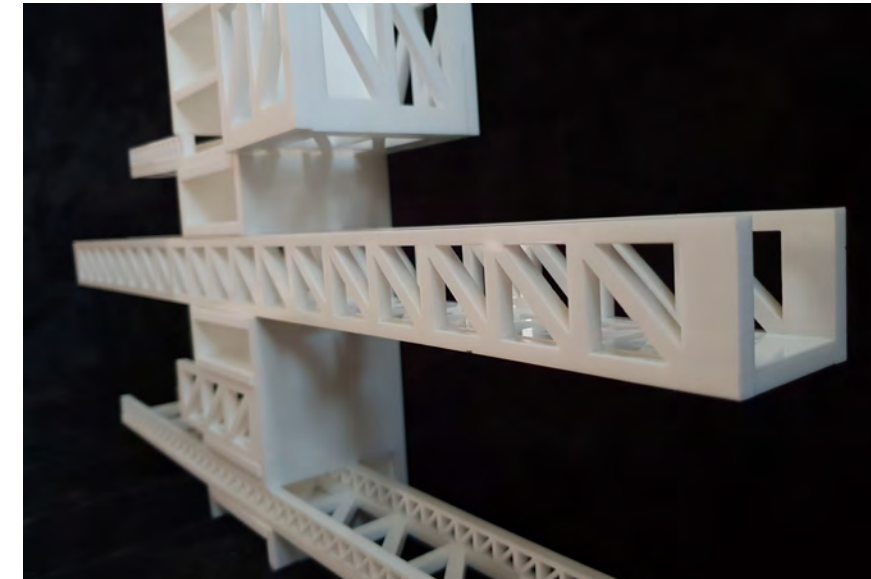

05

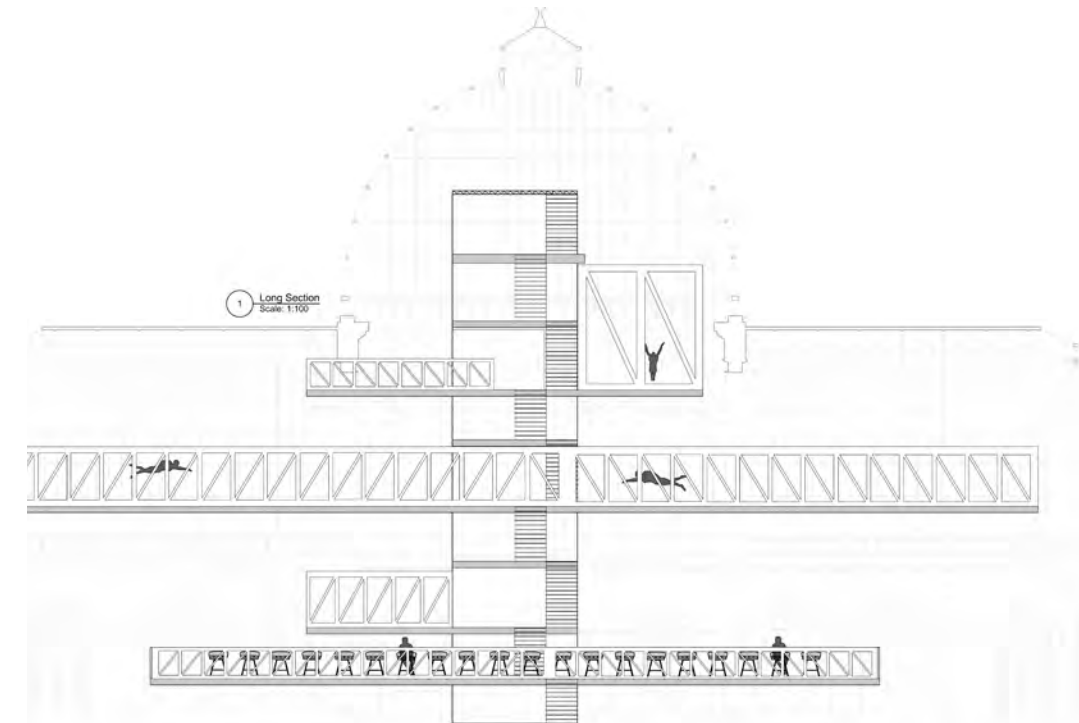

06

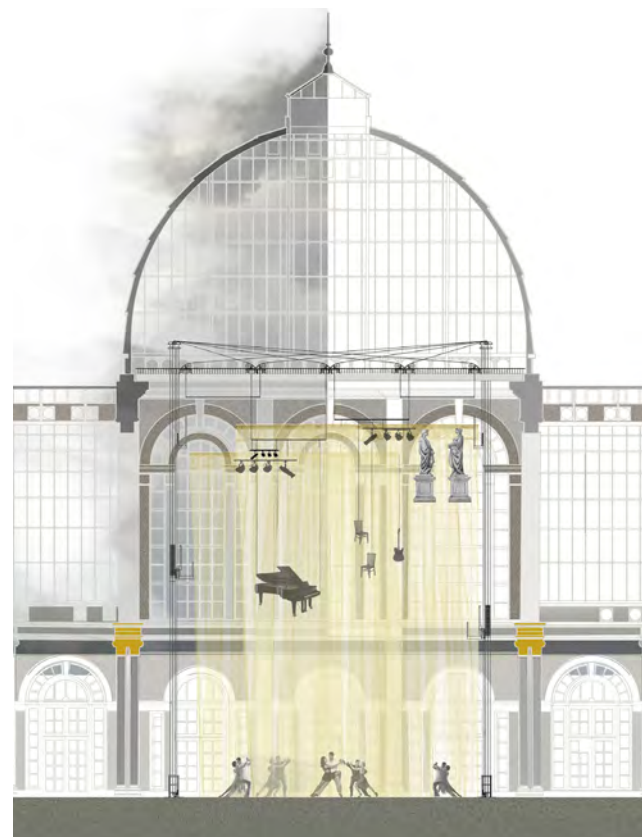

04

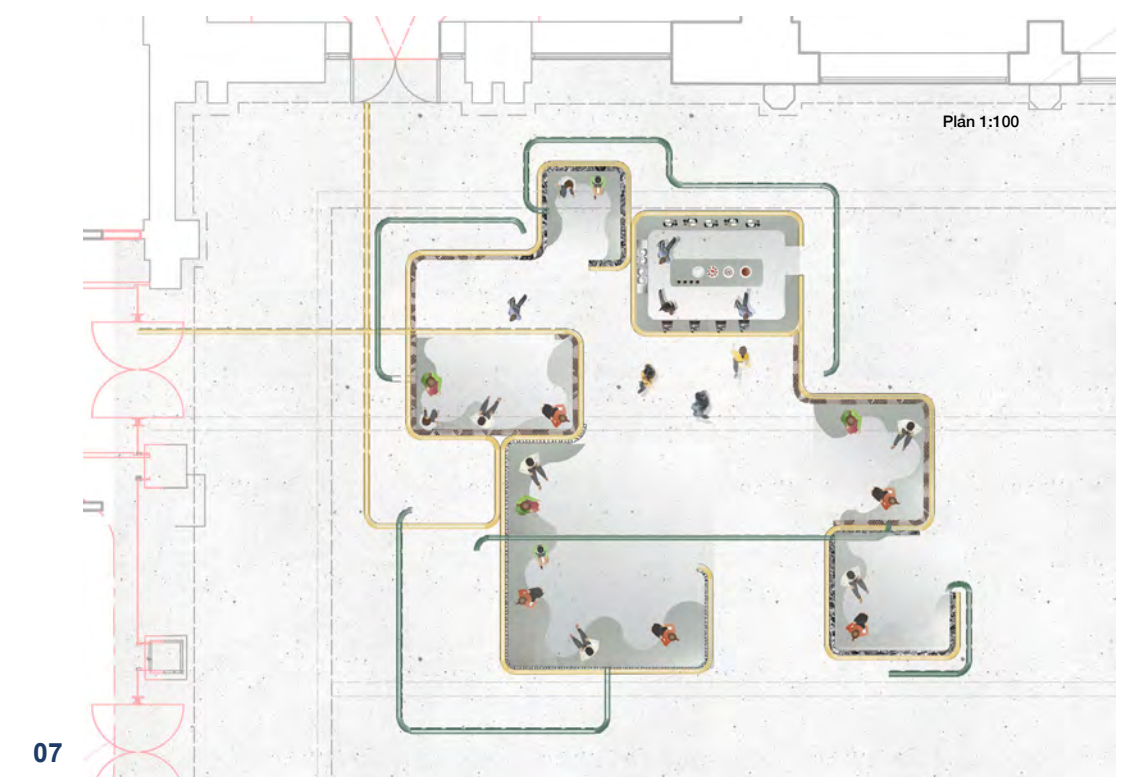
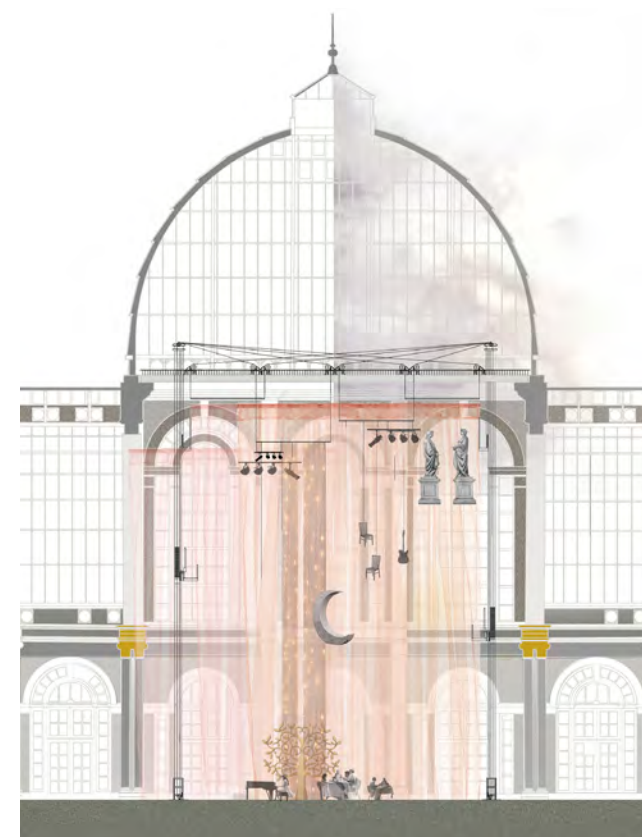

07

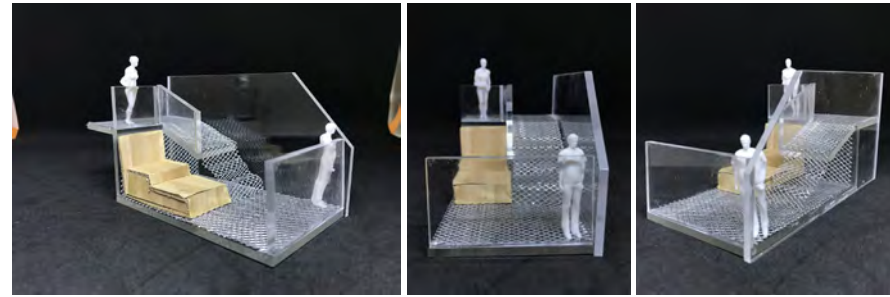

01

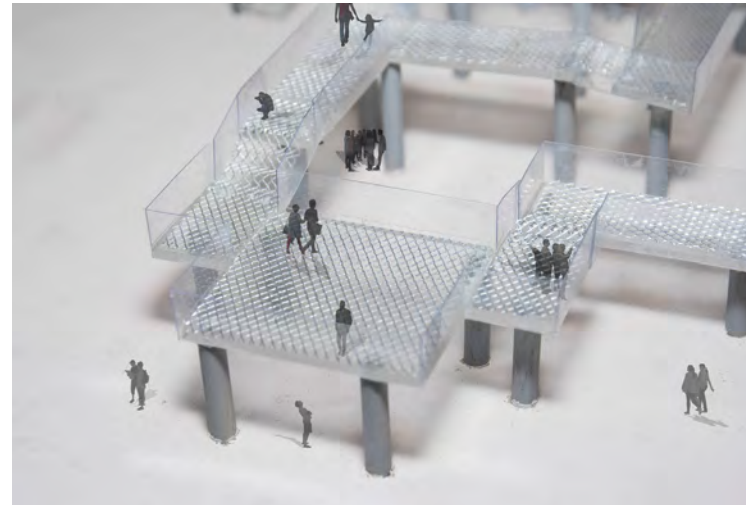

02

- 01 Daniel Brown
- 02 Daniel Brown
- 03 Elena Petrova Chomuklieva
- 04 Marieta Correia
- 05 Lucinda Hekneby
- 06 Jurate Cibulske

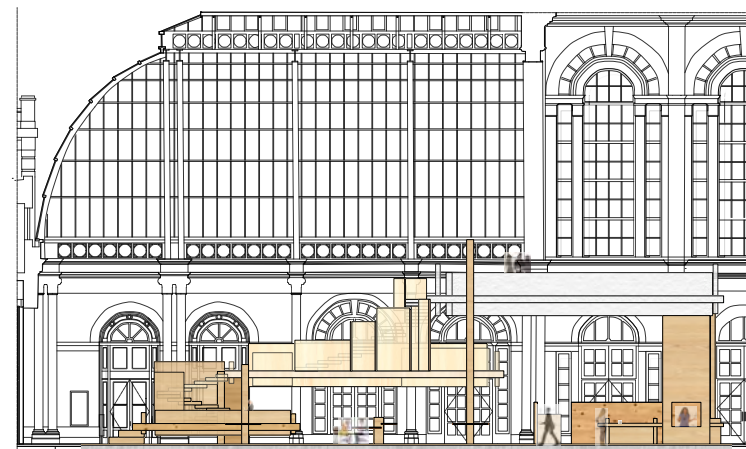

03



04



05

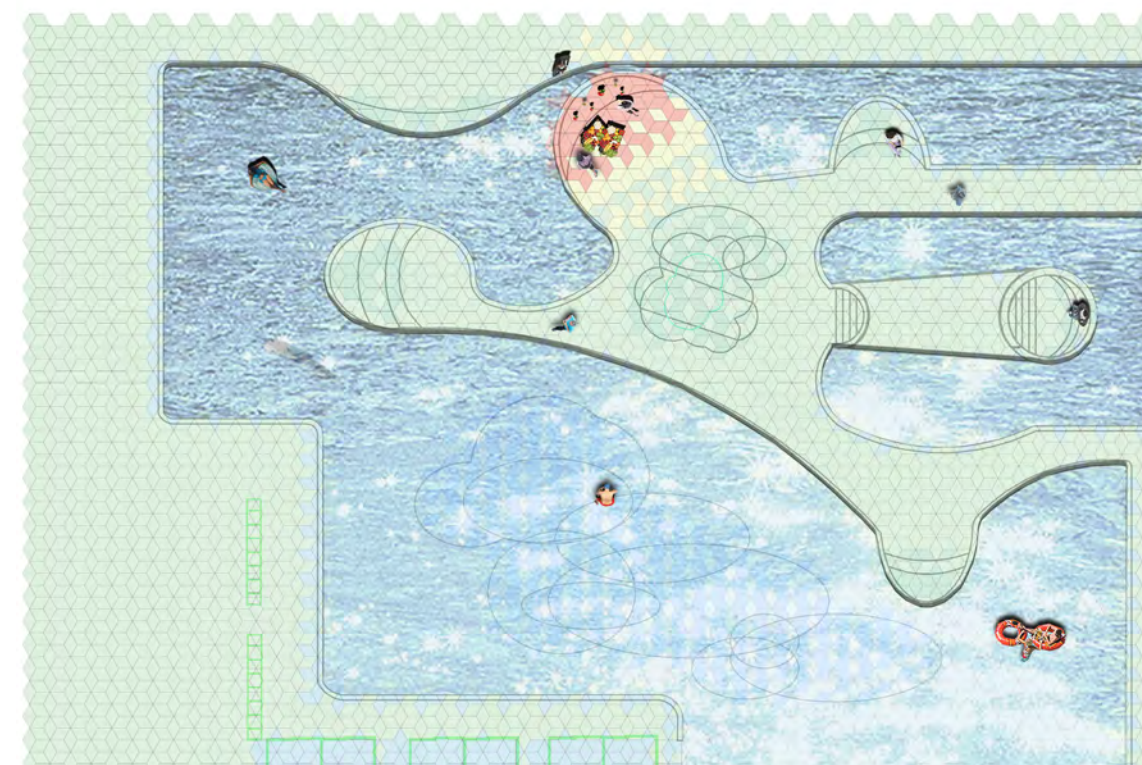

06

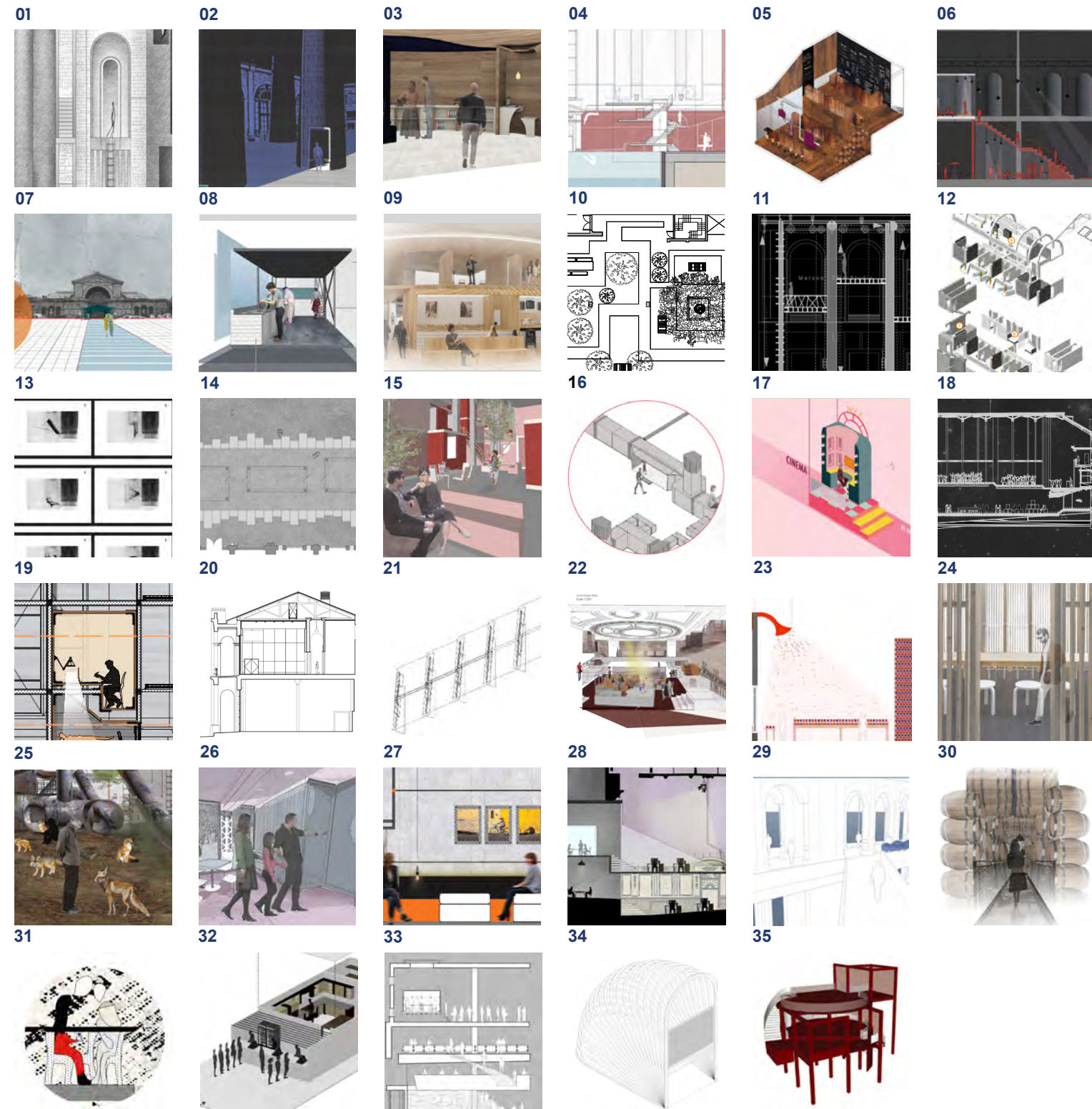

- 01 Ausra Kamicaityte
- 02 Shakera Rahman
- 03 Agnes Yeo
- 04 Polina Savinova
- 05 Deliyana Tsankova
- 06 Rasha Al-Dori
- 07 Dyna Russel Rabanal
- 08 Wafaa Mohd Halim
- 09 Dickson Kong
- 10 Nancy El-Mahdi
- 11 Sameeha Bashir
- 12 Al-Nadim Feysal Axmed
- 13 Karolina Charewicz
- 14 Magnus Fines-Conqule
- 15 Seda Altundal

- 16 Evangeline Osuji
- 17 Edlyn Xin Rou Tan
- 18 Minho Ju
- 19 Mahsa Khaki
- 20 Neha Halai
- 21 Ben Arcscott
- 22 Shu Ling Chai
- 23 Sheidasadat Khamooshi
- 24 Safa Sayeed Khan
- 25 Shiang Qian Lim
- 26 Pei San Goh
- 27 Chi Xin Ho
- 28 Marynelle Jacob
- 29 Iaina Ven Zie Low
- 30 Kornelija Kopustaite

- 31 Shermin Myumyun
- 32 Tian Chun Ong
- 33 Patrycja Poklek
- 34 Lih Ning Tee
- 35 Cai Ye



Image: BBC Wing, Alexandra Palace, 2018

the people's palace narratives, politics and education

In his *Manhattan Transcripts*, 1981, Bernard Tschumi said that architecture 'cannot be disassociated from the events that happen in it'. For Tschumi architecture is less about built form and more about interaction – as both material witness and collaborator in the 'event-world' that unfolds through and around it. Our work – as interior thinkers

and makers – is concerned with the idea of the interior as such an 'event-world' where the physical environment operates as a connection with the passing of time, and spaces get *reinhabited* by new users, actions and ideas.

¹ Bernard Tschumi, *Manhattan Transcripts* (John Wiley and Sons, 1994).

Interior Architecture students this year have been involved in a collaborative project with Alexandra Palace, a large, historic entertainment complex in the London Borough of Haringey in North London. The building – or rather the complex of buildings enclosed in a facade that operates as a boundary – has an extraordinary and troubled past.

First opened in 1863, the building has survived two fires, operated as an internment camp during World War 1 and 11, as well as hosting the first ever television broadcast in 1936. The remarkable and unusual series of events that have shaped its internal and external spaces have also somehow prevented Alexandra Palace from finding a new role in the city: today Ally Pally as it is affectionately known, is an exhibition space, a venue for a range of live events and one of London's biggest indoor ice rinks.

In 2013 Alexandra Place was awarded £18.8 million from the Heritage Lottery Fund, which helped to kick off the rethinking and remaking of some key spaces. The East Wing will become the People's Palace learning and participatory space, and the Victorian Theatre, dating back to 1875 and sensitively restored will host a full programme of different kinds of performances. The BBC television studios A and B also survive and are still in the process of being re-imagined with a substantially different shape and content.

Designing in Alexandra Palace has meant the investigation of space that is 'post' interior - empty of human occupation, yet nevertheless responsive and alive. Alexandra Palace is a strange place - empty for much of the time, 40% of the building is currently derelict or unusable, and the events that take place within its 30,000 square metres leave little evidence or trace, but a multitude of memories instead. Not even the building's legacy as the site of the first television broadcast in 1936 and its subsequent iteration as television studios, or indeed the Victorian Theatre (currently being renovated), have left many material traces. This is a building that is continuously reused, yet without any 'adaptation' – and has become over time deprived of content and meaning. What persists, and remains in the public domain, is a 'memory space': the challenge facing Alexandra Palace is how to add new meaning to this existing narrative.

The key underlying premise that as Interior Architects we work from is the understanding that the built environment is always time-specific – that is, it has been designed and built according to a time-specific idea and/or need. Importantly however, the life span of many buildings is often longer than the purpose for which they have been built. In light of the passage of time, buildings need to be updated to survive societal changes that affect their form, role and meaning.

During the first part of the year we explored the context of Alexandra Palace in a broad sense: the Palace itself to uncover its history and its present

“In the process of remodelling . . . the past takes on a greater significance because it, itself, is the material to be altered and reshaped. The past provides the already-written, the marked “canvas” on which each successive remodelling will find it’s own place. Thus, the past becomes a “package of sense,” of built-up meaning to be accepted (maintained), transformed, or suppressed (refused).”

————— **Rodolfo Machado, ‘Old Buildings as Palimpsest’, Progressive Architecture, November, 1976, pp.46-49.**

materiality, and the social, political and economic background of Hornsey, Wood Green and Muswell Hill that surround the Palace and Park, in order to identify new ways of interpreting the idea of a 'People's Palace'. Students operated as detectives, collecting information - fragments, traces of previous occupations - reconstructing the sequence of events, establishing priorities and registering effects.

The research themes were identified as follows:

01. Narratives / Post-interior the uninhabited building acknowledged Alexandra Palace as a strange place that is perennially in and out of use. As an exhibition and event space, it is a building that sits empty for much of the time – these transitory occupations transforming it with short bursts of activity. This research strand was interested in the stories that characterise the fluctuating inhabitations of the building and in the ways in which these narratives were evident in the building's materiality. What future might be possible for this giant structure other than as an inhabited space?

02. Politics / Reclaiming Public Space connected with the history of Alexandra Palace as 'The People's Palace', revealing its persona as a democratic space intended for the entertainment and education of the public. However the meaning of public space has shifted since the building was first opened and laissez faire economics have masked its gradual privatisation – where the threshold between public space and private space was at one time clearly demarcated, our transgressions into privately owned space have become increasingly omnipresent. This research strand was interested in how 'The People's Palace' might represent the re-emergence of public space, and the ways in which space can itself be designed to shape and influence the political landscape.

03. Education / New Learning Landscapes built upon the current plans for regenerating the East Wing of Alexandra Palace reconnecting the building to the local community through a programme of educational activities and events. The building, once renovation is complete will need to both host these activities and interface with schools and other institutions, reimagining the new learning landscapes that this prefigures.

Rooted in these themes, the design proposals of the first phase explored the threshold between the renovated Theatre and this new educational facility: this small-scale intervention was meant to address the immediate potential of the site defining strategies of intervention, whilst imagining how this can anticipate a more permanent occupation.

The solutions proposed ranged from spaces aimed at binding the community together through making (craft, photography, etc.); to support young talent by providing shared work/study spaces; to provide entertainment with new cinematic experiences; to facilitate communication with new debating spaces; to accommodate swimming pools and skate parks; to host new libraries and sustain a homeless retreat.

The following stage of the project identified a more complex programme able to occupy a new location either in the BBC wing of Alexandra Palace or in the Victorian Theatre, or in a few chosen buildings close by, to identify a possible cluster or network of activities. Each student developed their own brief, concept and narrative, which have shaped the



Images: Student site visit to Alexandra Palace theatre during restoration, 2018.

design process and outcomes. These outcomes are a fascinating constellation of diverse approaches, exploring in depth the needs and potentials of the local community and suggesting a new situated future for the 'People's Palace'.

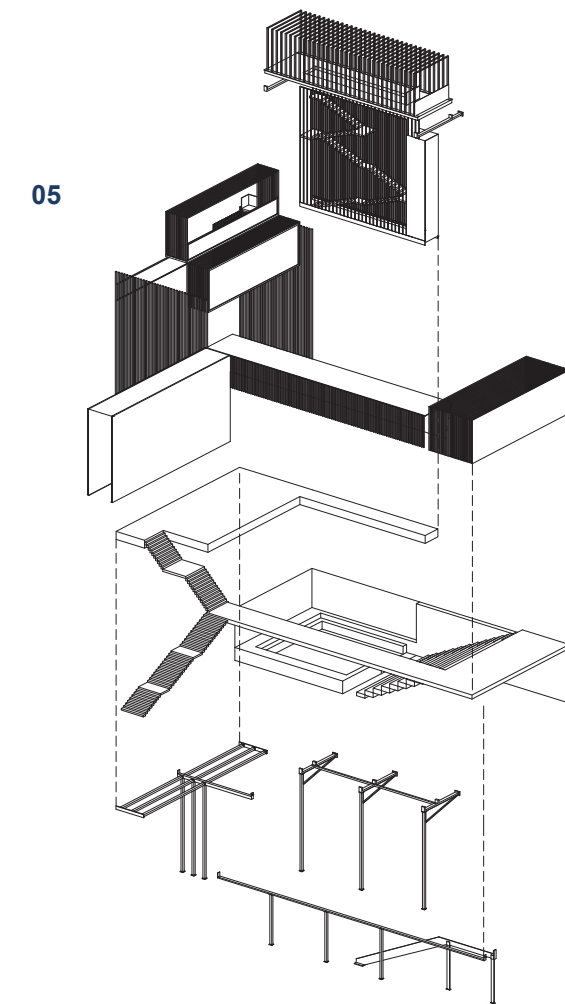
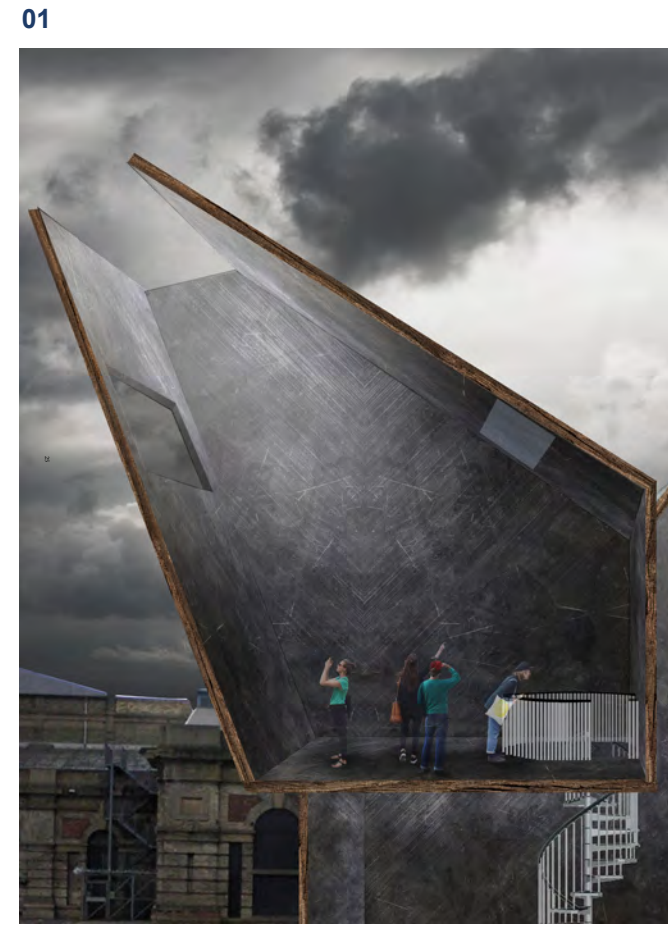
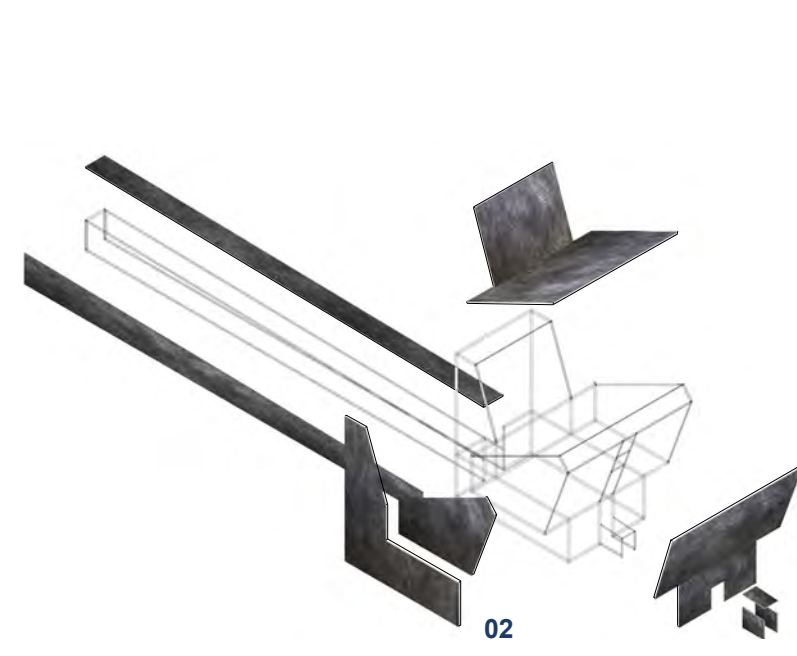

- 01 Patrycja Poklek
- 02 Patrycja Poklek
- 03 Ausra Kamicaityte
- 04 Ausra Kamicaityte
- 05 Lih Ning Tee
- 06 Wafaa Najihah Binti Mohd Halim
- 07 Shakera Rahman
- 08 Karolina Magdalena Charewicz

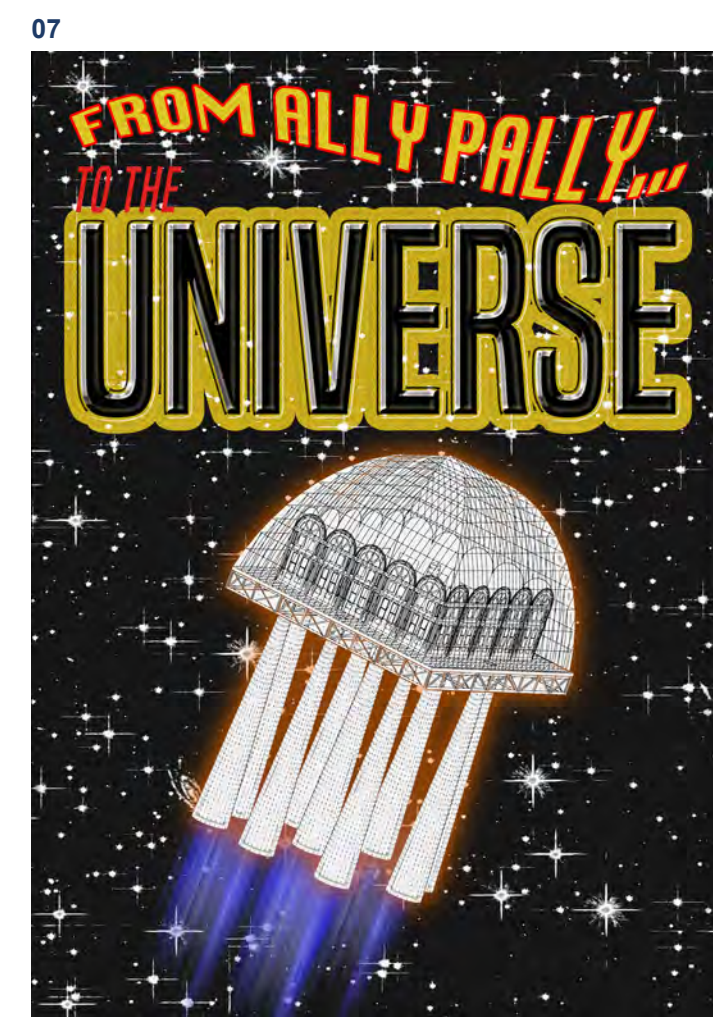
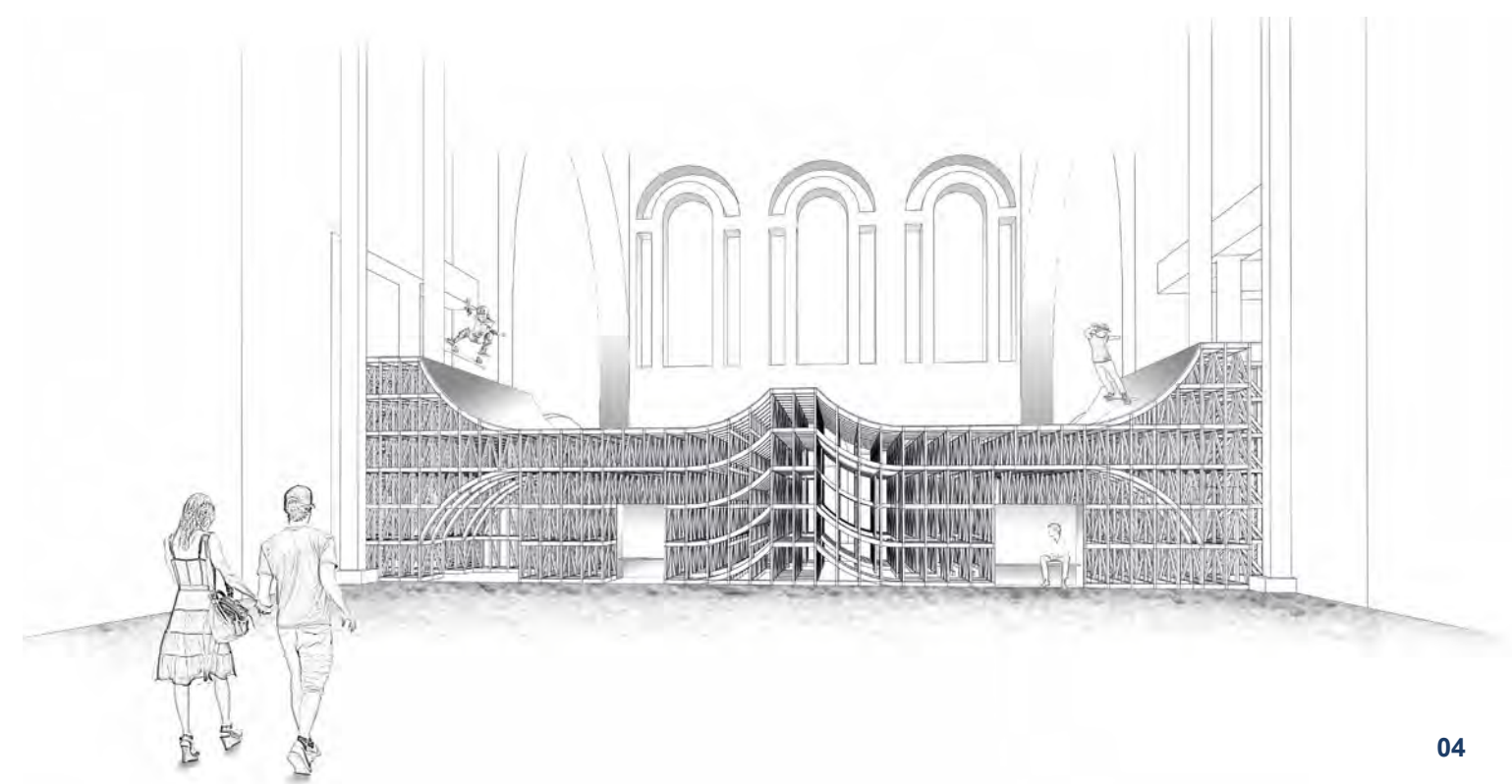
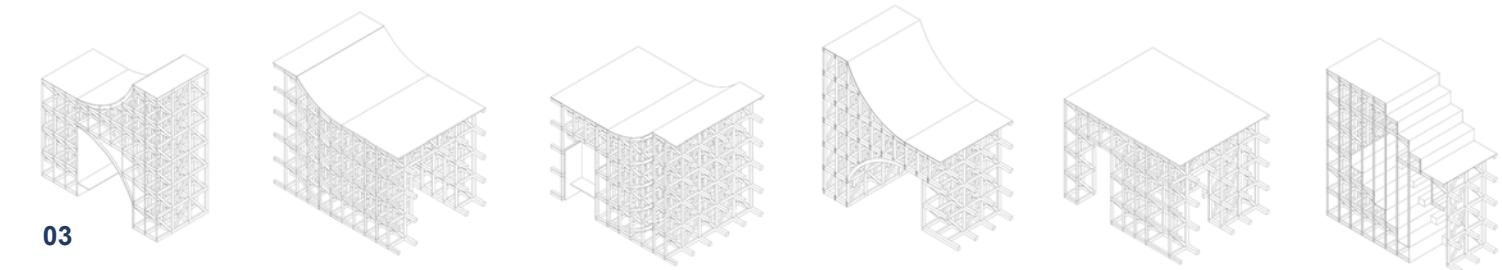

Decoding Objects

———— Sameeha Noor Bashir

‘Object’ measured by any standard is an extensive category. According to the English dictionary the word originates from the Latin word ‘obicere’ this referred to the act of blocking, in a sense of disapproval or objection.¹ Looking at the word philosophically, the definition has been aligned with a ‘thing that has been perceived’ by the eyes or other sense²; it is something external from the apprehending mind, subject or self. These philosophical factors also form another etymology of the word object as ‘action, feeling or thoughts that are directed’².

Objects are exemplified in many diverse roles, dynamics and capacities. A single discipline is not sufficient in order for an object to be studied with dedication. Therefore I will be looking at how objects are read through different disciplines and academic fields including; anthropology, film and television³, classical studies⁴ and several more. These fields can provide a good starting point for the in-depth study of object reading. Mainly they can offer vantages for the way we can study objects. One way to approach this as a starting point is to think about and think through objects . . .

The classification of objects can be further questioned through political theory⁵, sociology, semiotics, psychoanalysis and classics. These questions are raised on their meaning as well as their psychic and social functions. I will be analysing three short texts. The first one, ‘Why things matter’ is a text written by Julian Bleecker . . . Bleecker had written a corresponding manifesto article “A Manifesto for Networked Objects – Cohabiting with Pi-geons, Arphids and Aibos in the Internet of Things (Why Things Matter)”. In this article, he wrote about the advanced notion of “presence” as it commonly existed prior to the development of technology. Now the “presence” becomes a “remote presence” which is ‘blogject’, a term he introduced in his manifesto.

Blogject can precisely be translated as ‘object that blogs’. A further explanation is that blogject is an animate object that is able to find and store the location of where they have been, and can remember their previous experience, and encounters. Blogjects always have some form of agency, they imitate action and participate, and they are able to interact with the users on social networks . . . His view is that ‘things’ will have to be taken in to account as they assume the role of socially relevant actors and strong-willed agents that create social capital and reconfigure the ways in which we live within and move about physical space. He utilized the word blogject to distinguish the instrumental character of things connected to the Internet of social networks.

How does gentrification encourage social cleansing and can it be harnessed to ensure local communities thrive instead of survive?

———— Shakera Rahman

Regeneration is a term often used by councils and developers to deceptively hide the destruction of communities and livelihoods. A term that seemingly presents itself as having a positive impact on an area can have destructive and fatal consequences as seen in the Grenfell Tower tragedy. Social cleansing is something that has been regularly brought up in conversation in recent years due to its visible impact on an area and on the locals living there. “The ‘right hand’ of the state helps to establish gentrification and works in tandem with individual desires for inner-city social cleansing.”¹ Social cleansing is one of the results of regeneration that is often overlooked by developers and local authorities. Gentrification in Brooklyn, New York has reached such a peak that the average resident must now spend 124% of their wages to meet the monthly payments on a median-priced home² and has now become “America’s most unaffordable place to buy a home”³. As a result of this residents that thought they would be residing in Brooklyn for the rest of their lives have been cruelly displaced as the area has become too expensive to live in.

Social cleansing means “the large-scale removal from an area of members of a social category regarded as undesirable”. These ‘undesirables’ in Brooklyn are usually the lower working class, the poor and ethnic minorities. One specific ethnic group that has lost out the most from the gentrification of Brooklyn, are the Hispanic population. The Hispanic population in Brooklyn alone has dropped from 513,242 in 2015 to an estimated 505,183 last year — a 1.6 percent reduction, the National Institute for Latino Policy president Angelo Falcón said⁴. This figure not only shows how minorities suffer for the most from displacement but also how low-income earners are affected by it. The increase in housing prices meant the Hispanic population could no longer afford to live there and in turn left their lives in Brooklyn behind. Developers and governments advertise

their new developments as ‘affordable housing’, not taking into consideration what is considered ‘affordable’ to those that already live in that area. These house prices are used as a tool to drive out low-income and ethnic minority residents and bring in more affluent residents, usually middle-class, white residents, and thus contribute to the gentrification of an area. In Bushwick, the Latino population shrank by 13 percent over the 15-year span while the white population increased 610 percent from 3,207 to 22,776. This figure shows gentrification is clearly a racially motivated act, designed to socially cleanse communities of people that are not considered to help increase the profits of developers and councils.

Racially motivated is a term that was used frequently in the Grenfell Tower tragedy in June 2017. There is no denying that the residents occupying Grenfell were mainly ethnic minorities, would the same disaster have happened if they were white, middle class occupants? “You know why they aren’t here yet? We’re migrants, immigrants, refugees.”⁵ This is what some of the residents of Grenfell had to say about the lack of officials during the crisis. The racist backlash that came from spectators of the fire certainly proved how prominent it was that Grenfell had a large ethnic population⁶. The racism came in all forms, from white people living up north that were completely detached from the whole situation to click-bait media journalists whose only job was to cause unnecessary, compassionless discord. One particular opinion that received incredible backlash was a tweet by journalist, Katie Hopkins. She suggested that the residents living at Grenfell were illegal immigrants receiving compensation for the Grenfell fire just because they were migrants and compared this to pensioners and war widows who we can infer from her tweet as being white, working class as opposed to ethnic and working class.

¹ Candlin, F. and Guins, R. Baudrillard, J. Bleeker J, Stallabras J.(2009). *The Object Reader*. Milton Park, Abingdon, Oxon: Routledge.

² *ibid*.

³ One particular example is ‘The Way Things Go’ by Fischli and Weiss. It documents a long causal chain assembled of everyday objects, resembling a Rube Goldberg machine. I will go in to this further on in this piece of writing.

⁴ Classical studies can be applied to object reading through archaeology.

⁵ Political theory is the categorization of social thought by a group or by the persuasion or beliefs of a geopolitical mass. These social thoughts can also be applied to the reading of objects. Similarly, existing political, economic and social conditions of the theorist’s time can also be applied.

¹ Lees, Loretta, Hyun Bang Shin, and Ernesto López Morales. 2015. *Global Gentrifications*. Policy Press.

² 2018. <https://www.realtytrac.com/news/company-news/q3-2016-home-affordability-index/>.

³ Carpentier, Megan. 2018. “The Last Battle For Brooklyn, America’s Most Unaffordable Place To Buy A Home”. *The Guardian*. <https://www.theguardian.com/cities/2016/oct/03/last-battle-Brooklyn-new-york-americas-most-unaffordable-place-buy-home>.

⁴ “These People Are The Biggest Losers In Brooklyn Gentrification”. 2018. *New York Post*. <https://nypost.com/2017/11/06/hipsters-are-driving-low-income-hispanics-out-of-brooklyn/>.

⁵ Dokal, Hanna-Johara, Miriam Walker-Khan, and Katherine Soroya. 2018. “The Classist, Racist Disorganisation At Grenfell Tower Is Disgraceful | Gal-Dem”. *Gal-Dem*. <http://www.gal-dem.com/the-classist-racist-disorganisation-at-grenfell-tower-is-disgraceful/>.

⁶ “Sympathy revoked”. A term I saw frequently on twitter after it emerged that the majority living in Grenfell were ethnic minorities and that they had been displaced to million pound penthouses in Kensington. I found it amazing how after such a horrendous tragedy, the idea that the Grenfell residents were not happy being displaced far away from everything they knew seemed to be a sign that they were ungrateful. Many compared terrorist attack victims to the Grenfell victims and mentioned how they didn’t receive anything for that however is a terrorist attack really the same as intentional neglect by the people that are supposedly in charge of your welfare? The callousness of the Grenfell tragedy is far superior to any terrorist attack. Why? Because millions of people living in social housing have put their entire lives in the hands of an authoritative figure that they deem to trust, only for them to cut corners on safety and repay them with being burnt alive in a fire because of these cuts.

01

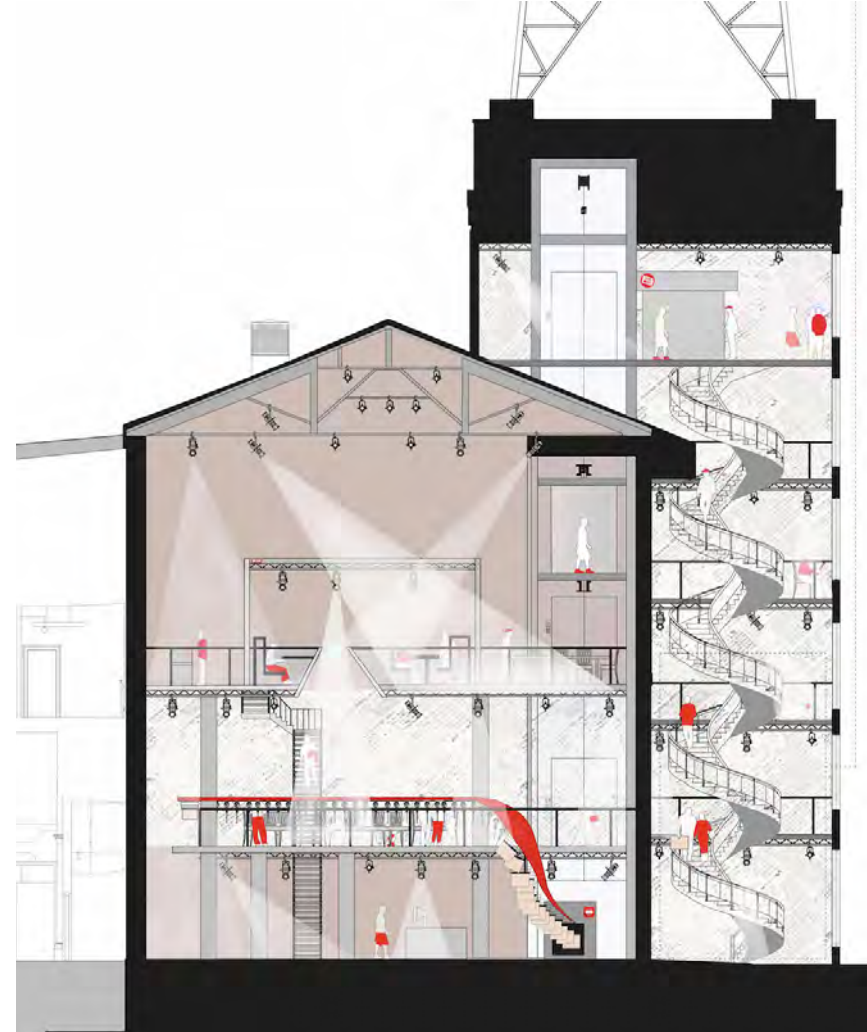

02

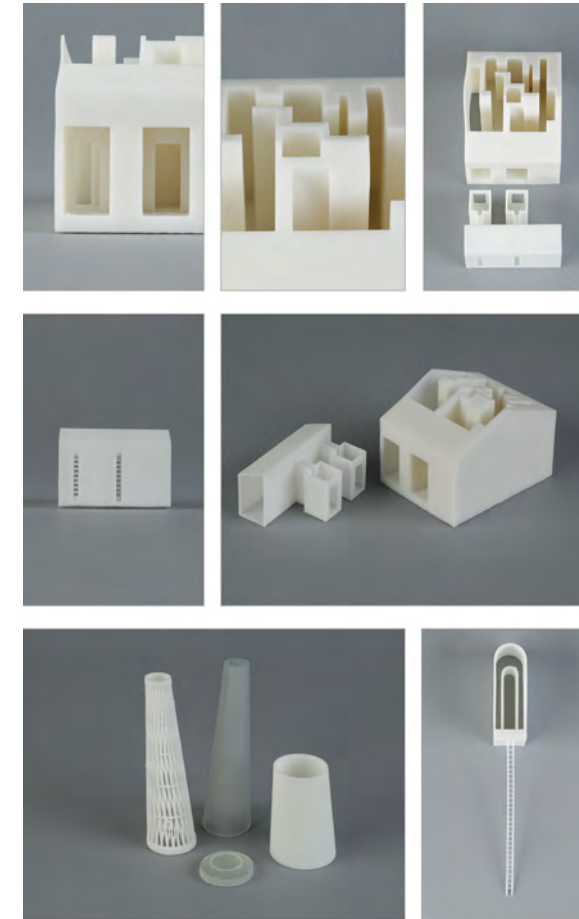

05

- 01 Shermin Myumyun
- 02 Shermin Myumyun
- 03 Patrycja Poklek
- 04 Rasha Al-Dori
- 05 Ausra Kamicaityte
- 06 Ausra Kamicaityte
- 07 Ausra Kamicaityte
- 08 Karolina

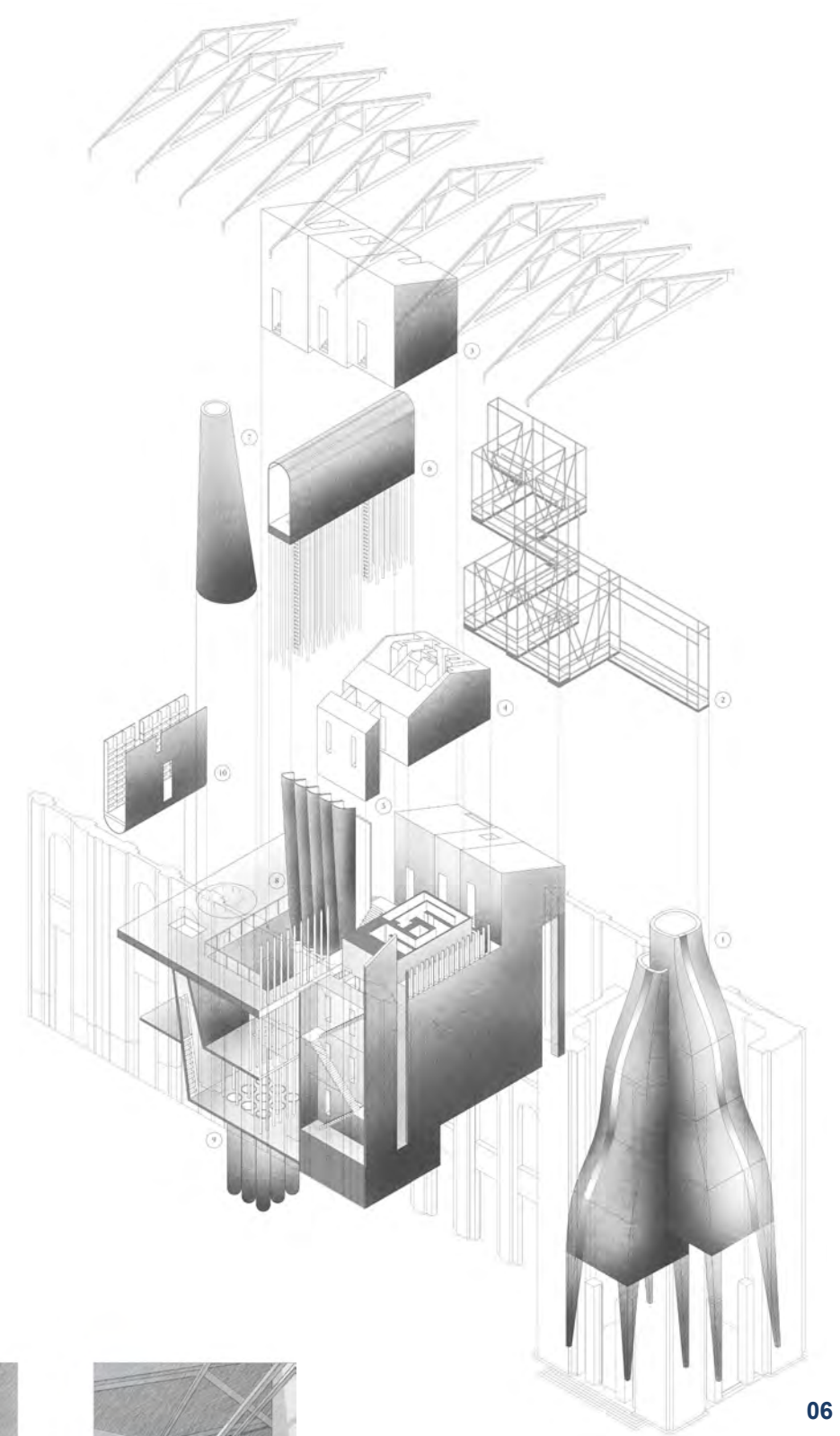

06

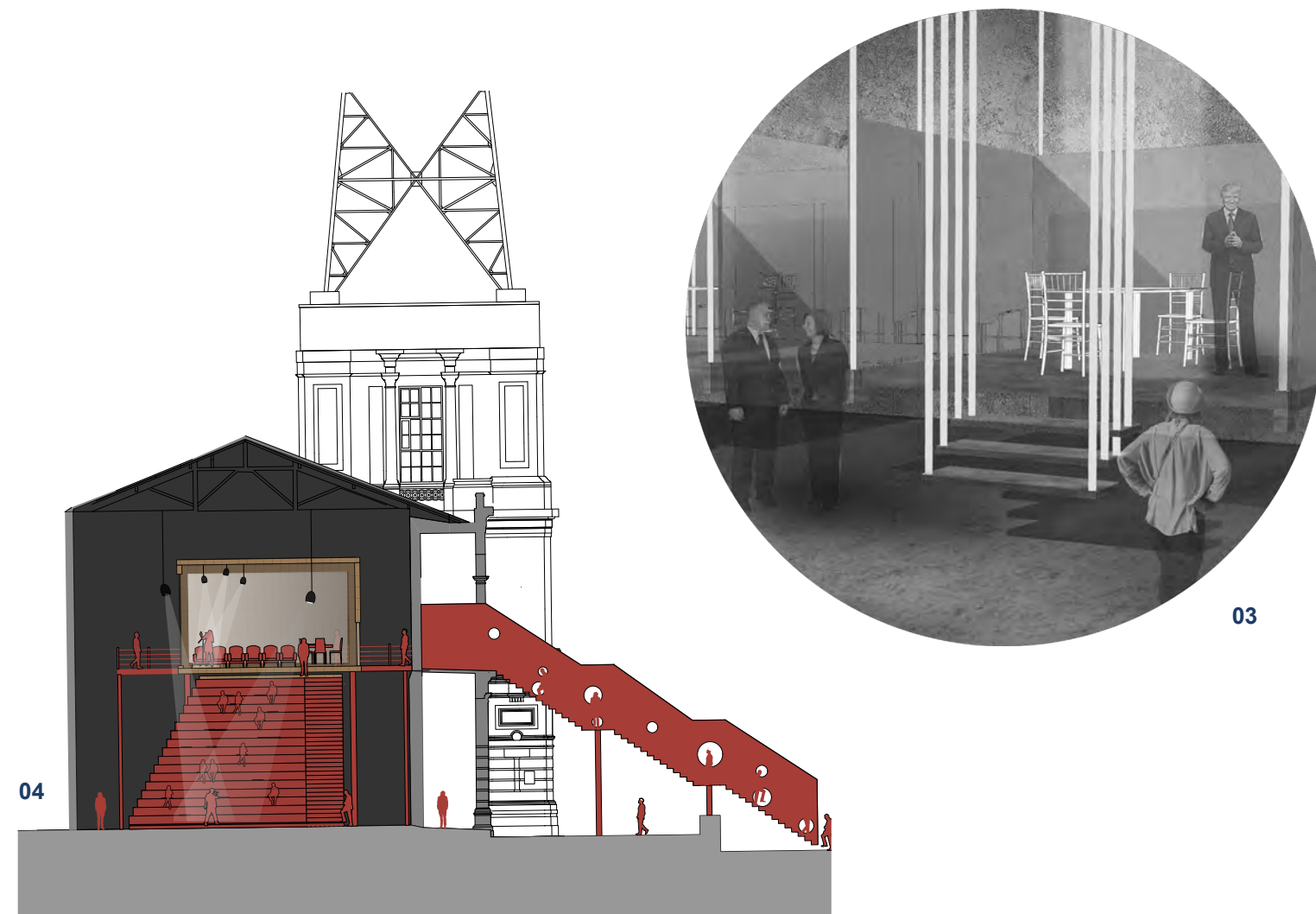

03

04

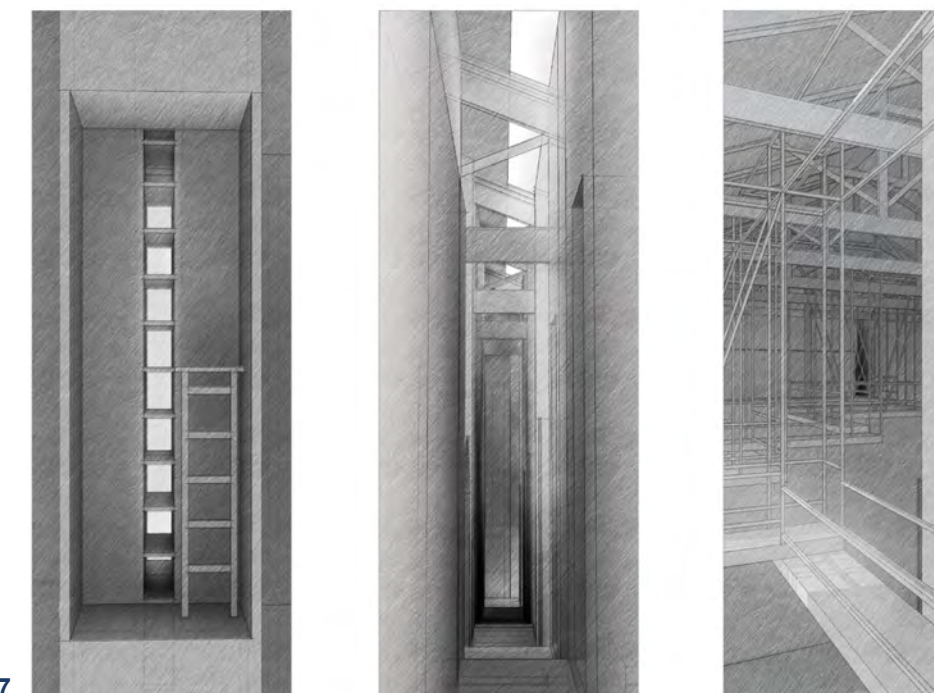

07



01

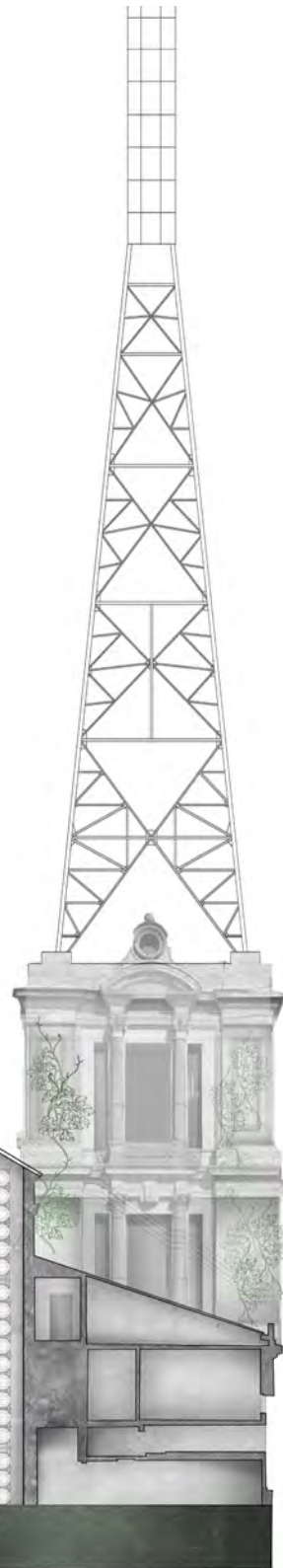

02

- 01 Kornelija Kopustaite
- 02 Kornelija Kopustaite
- 03 Mahsa Khaki
- 04 Nancy El-Mahdi
- 05 Lih Ning Tee
- 06 Wafaa Najihah Binti Mohd Halim
- 07 Wafaa Najihah Binti Mohd Halim
- 08 Al-Nadim Feysal Axmed
- 09 Dyna Russel Rabanal
- 10 Dyna Russel Rabanal



03



04



05

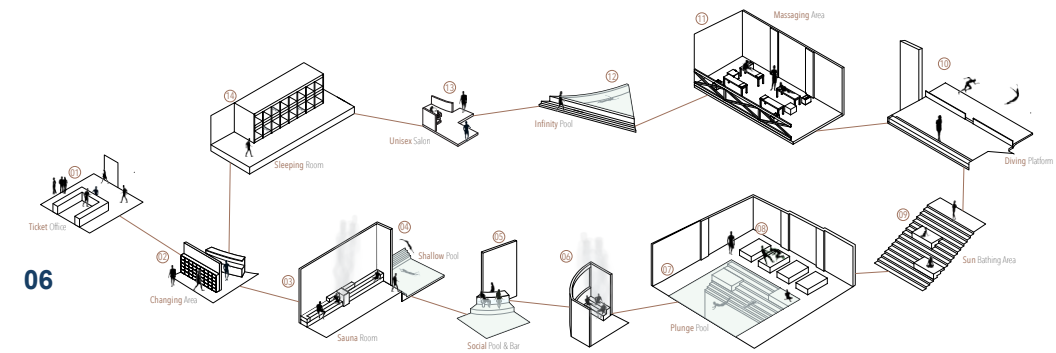

06

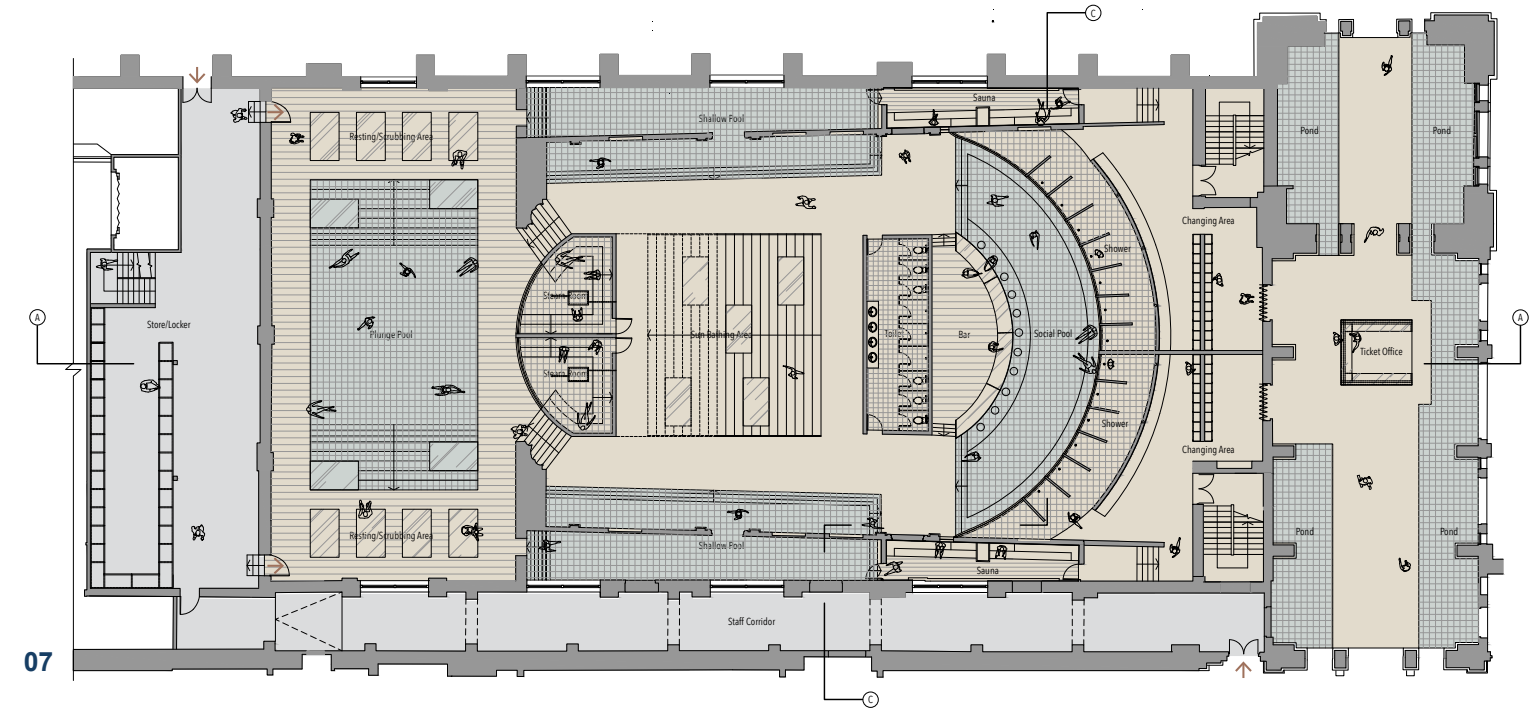

07

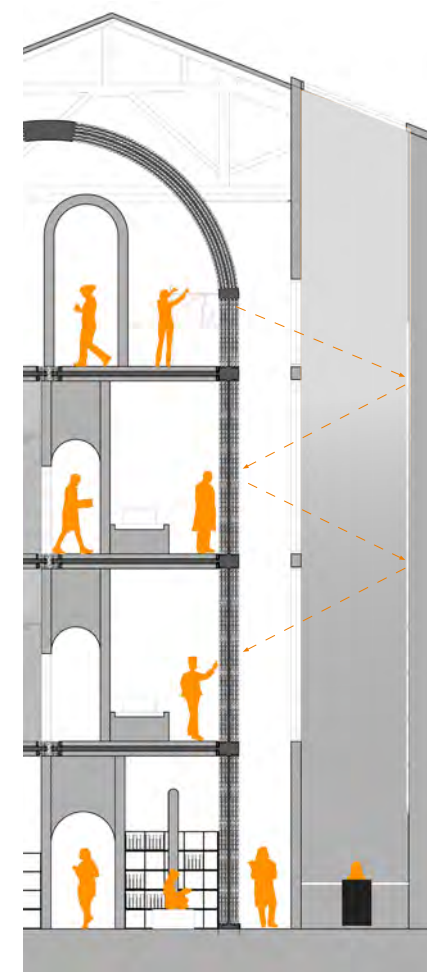

08

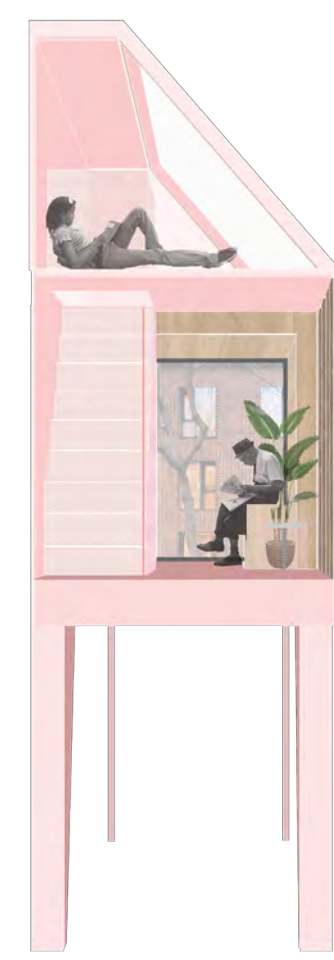

09

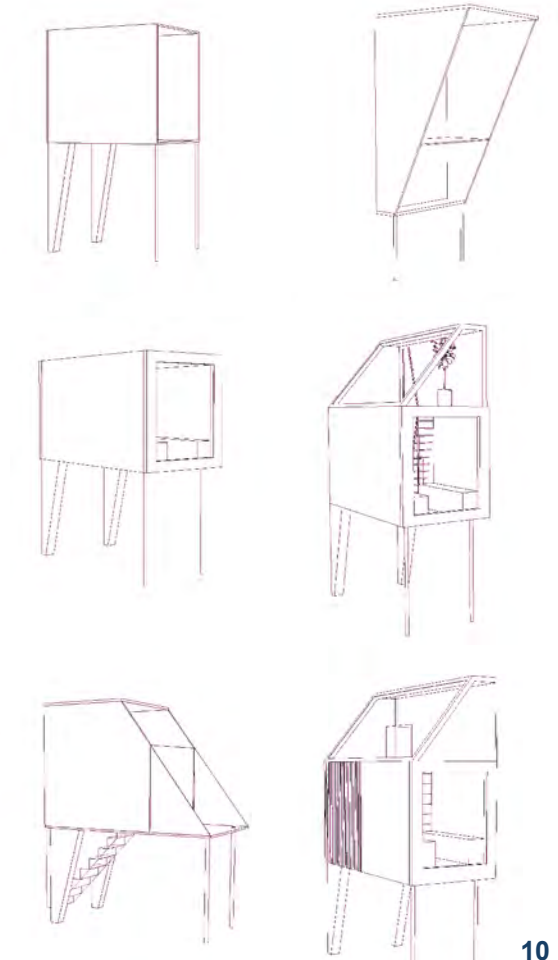

10



01

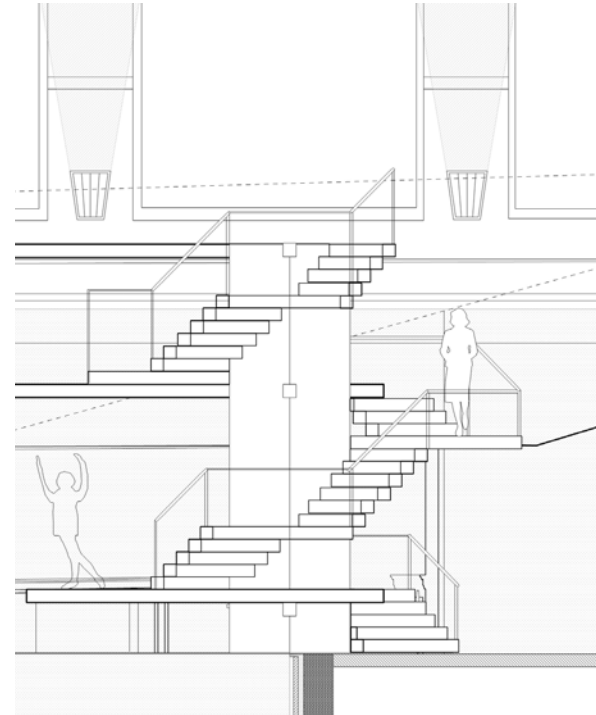

02



03

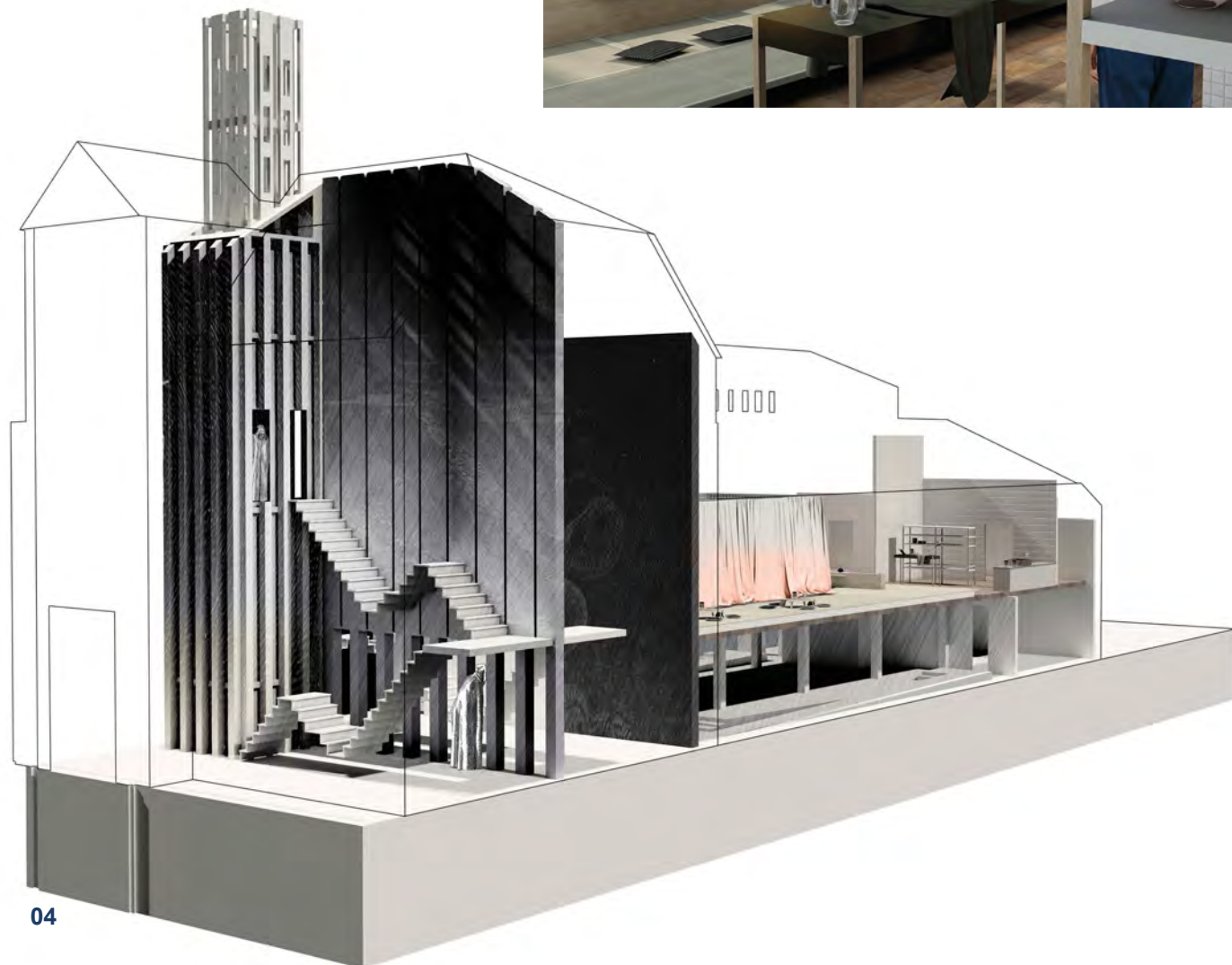

04

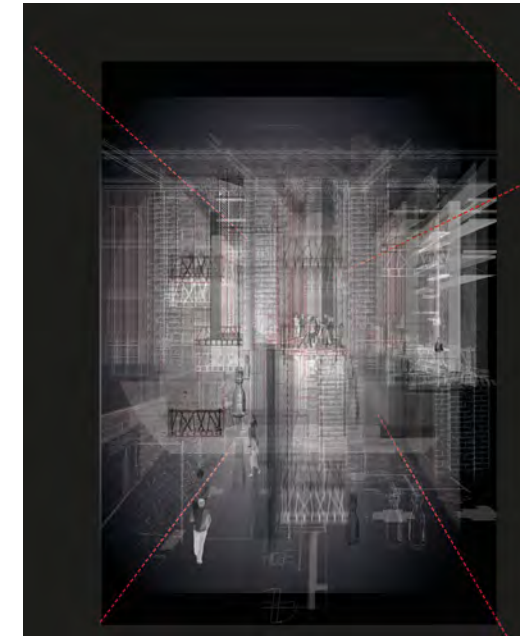

05



06

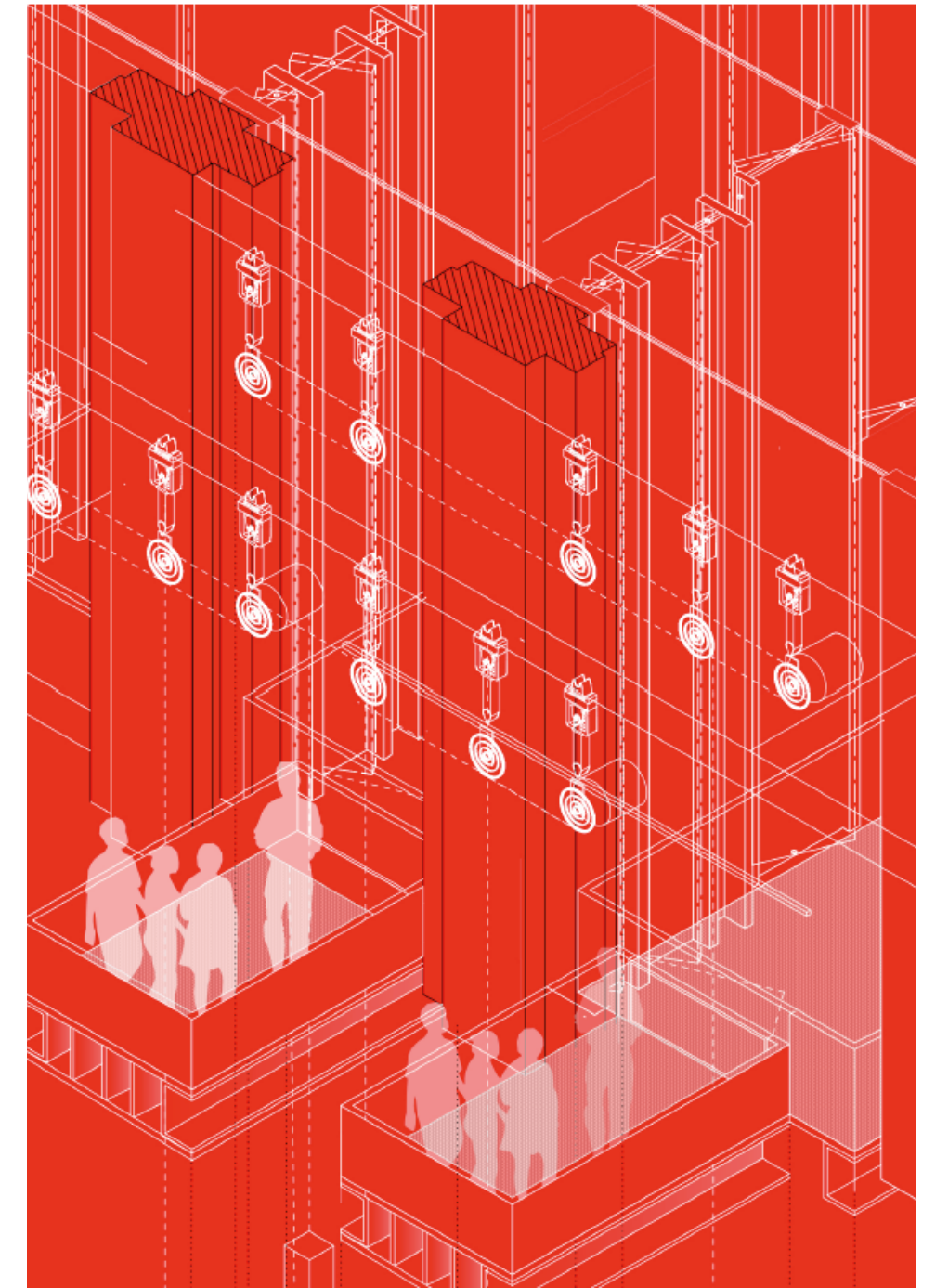

07



08

- 01 Polina Savinova
- 02 Polina Savinova
- 03 Karolina Magdalena Charewicz
- 04 Karolina Magdalena Charewicz
- 05 Sameeha Bashir
- 06 Sameeha Bashir
- 07 Sameeha Bashir
- 08 Chi Xin Ho

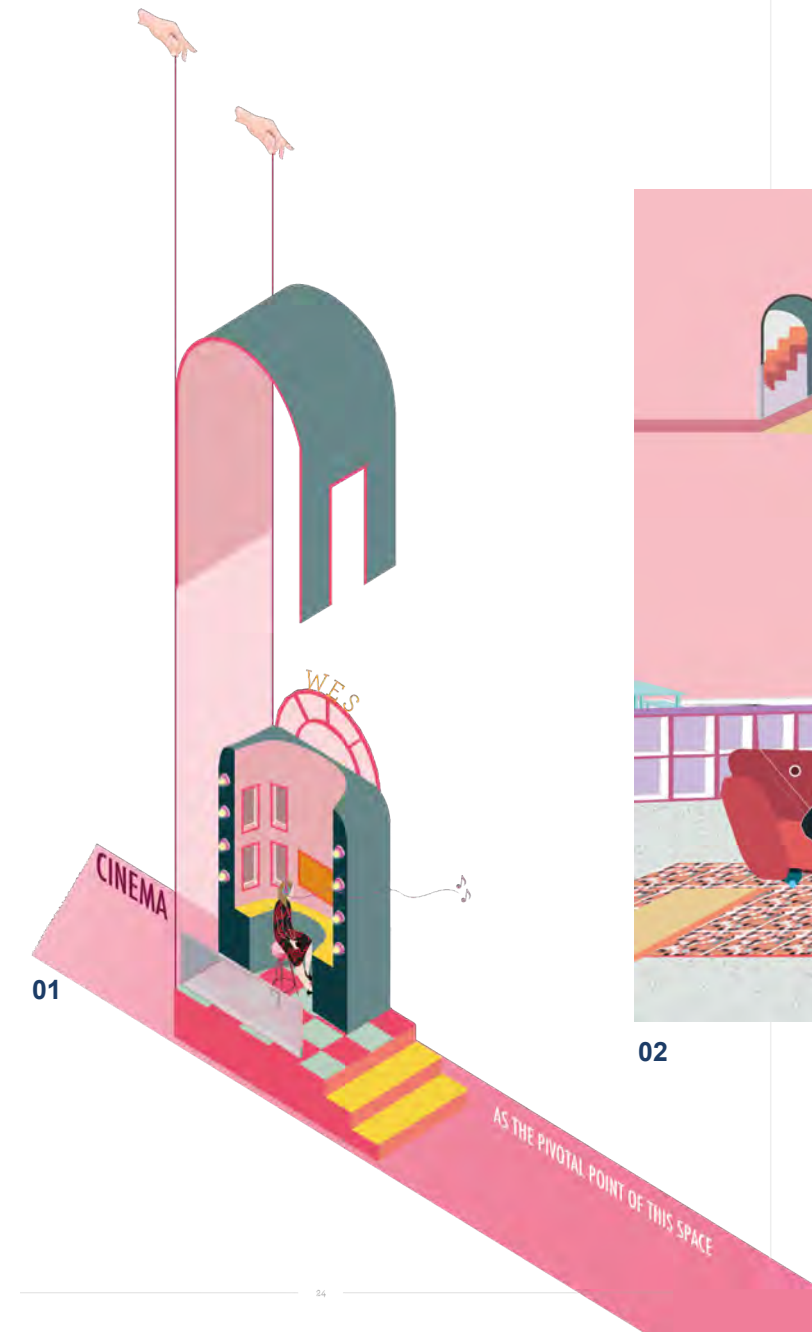

01



02

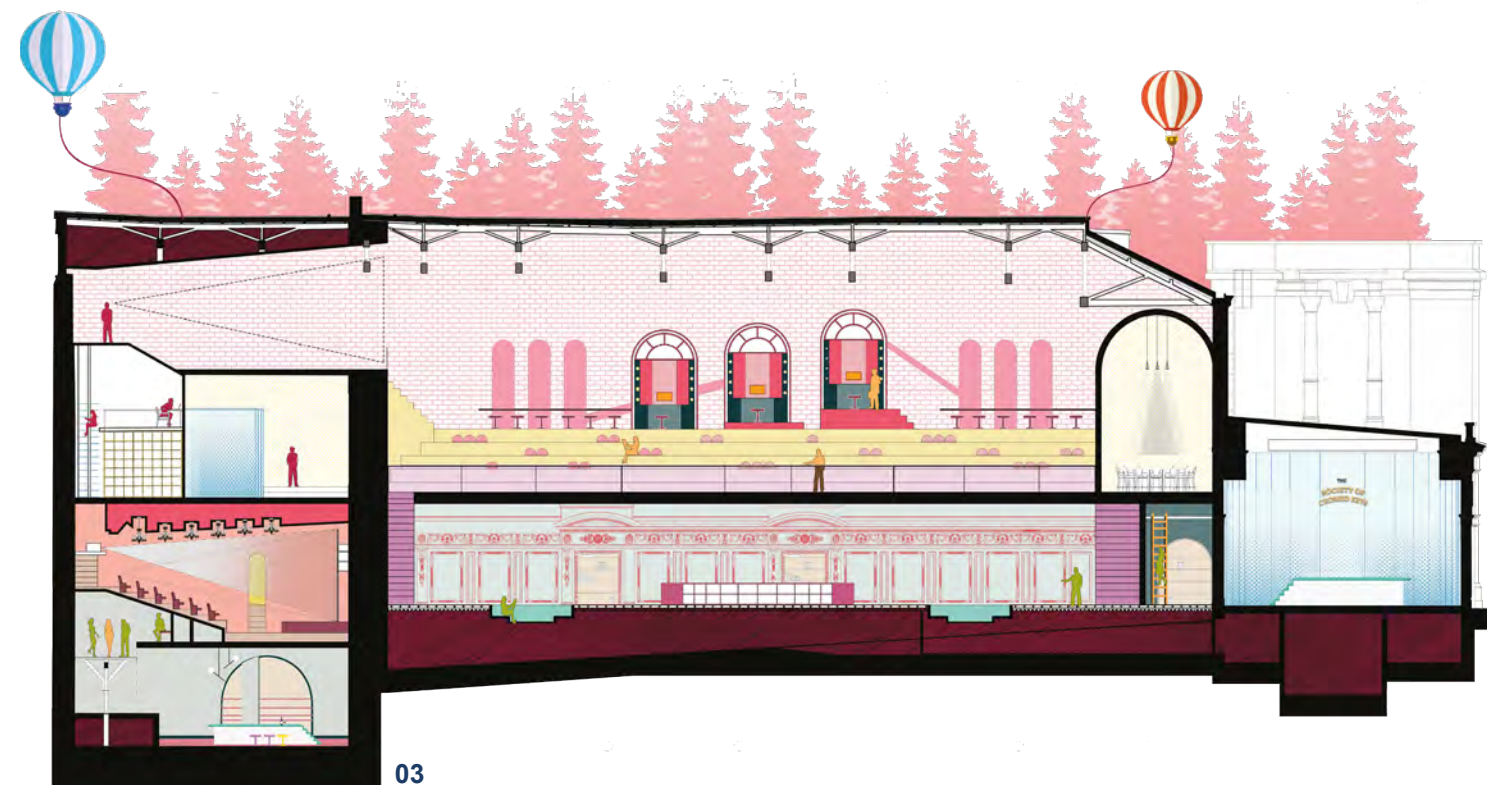

03



04

- 01 Edlyn Xin Rou Tan
- 02 Edlyn Xin Rou Tan
- 03 Edlyn Xin Rou Tan
- 04 Iaina Ven Zie Low
- 05 Iaina Ven Zie Low
- 06 Iaina Ven Zie Low

GIN DISTILLING PROCESS

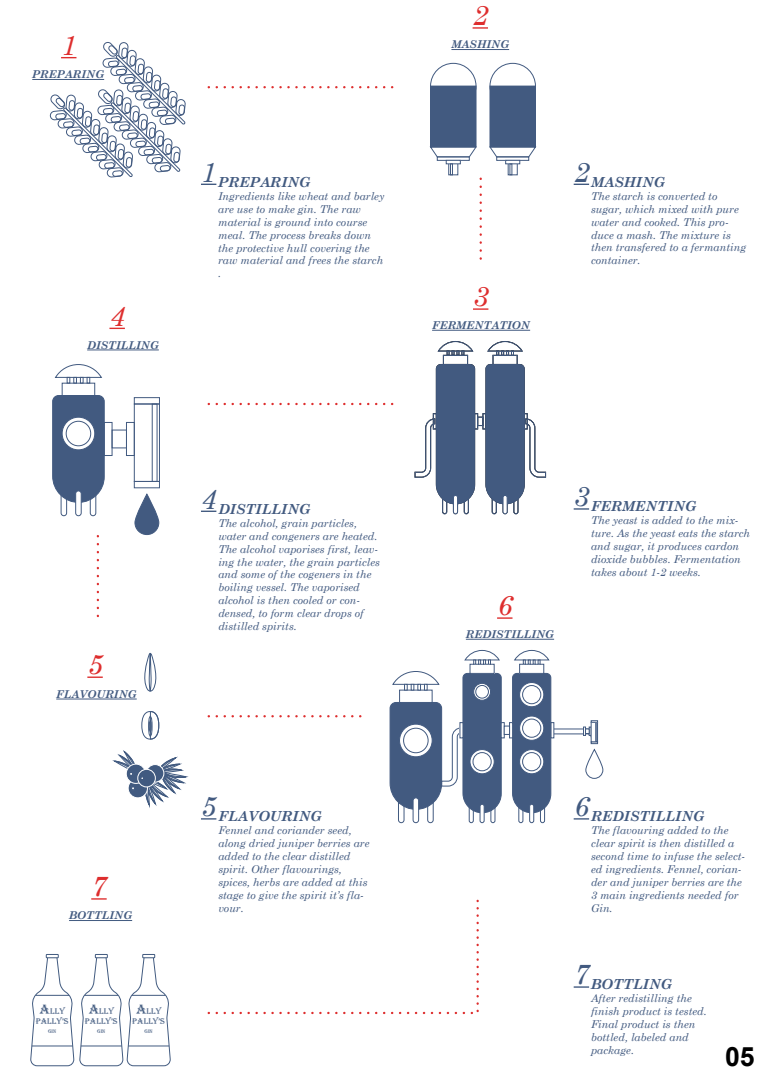

05

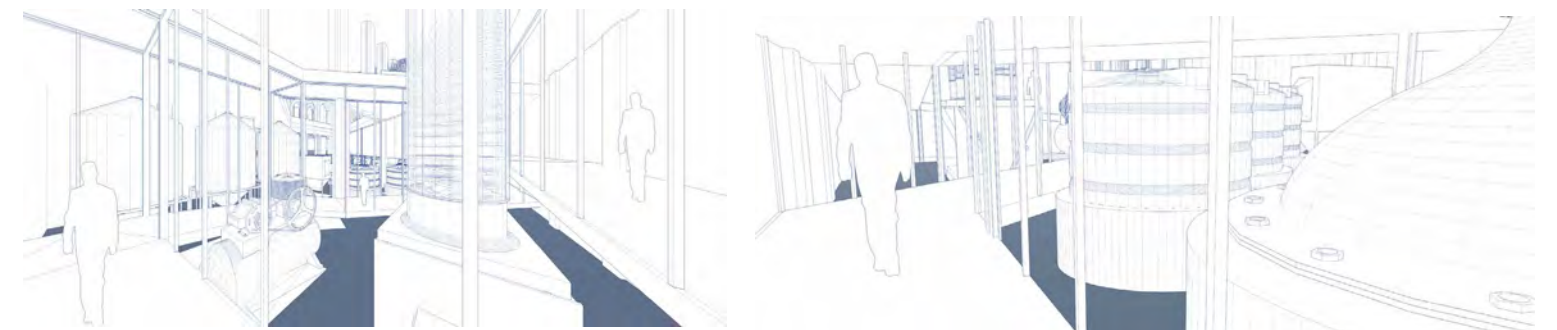

06

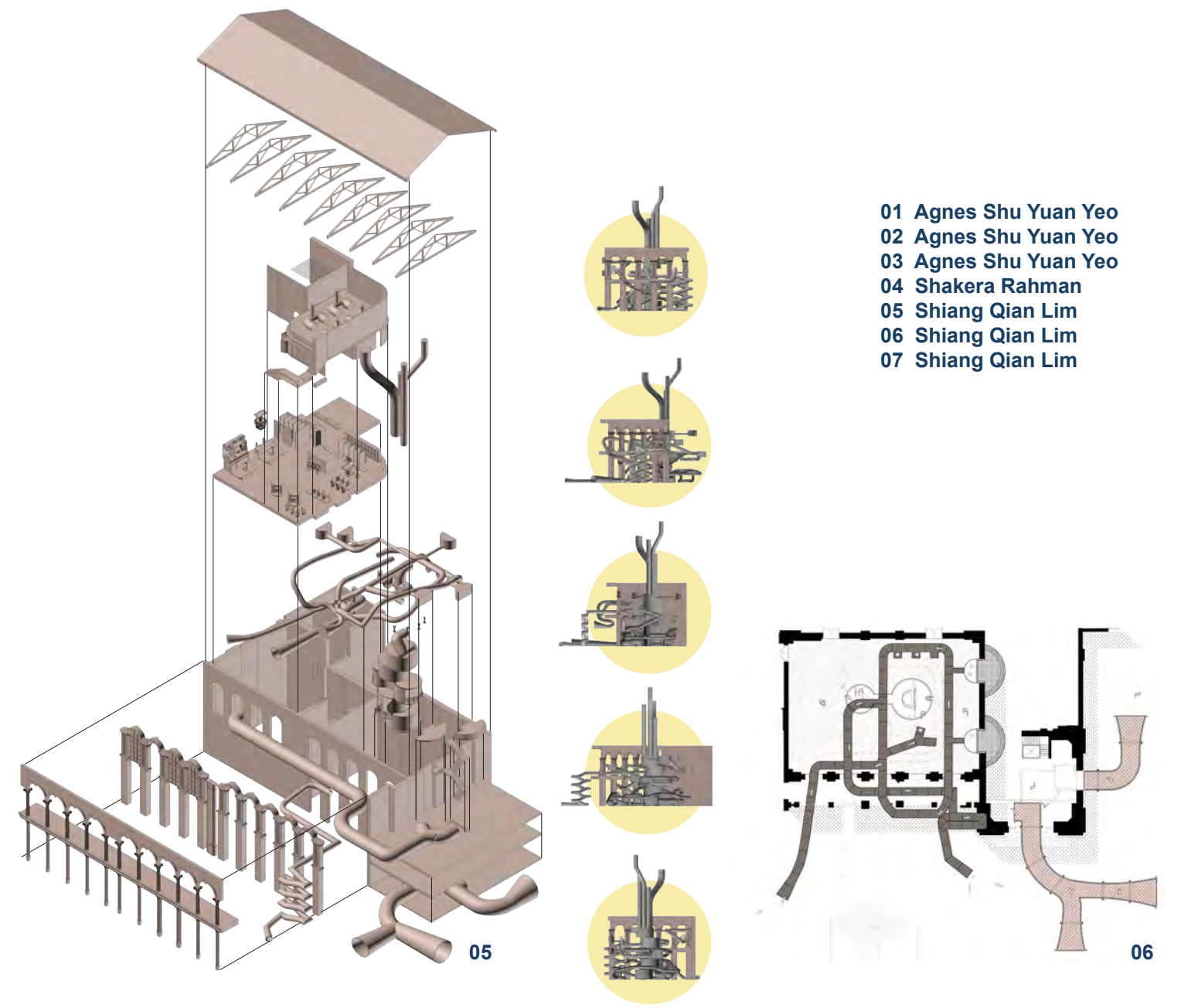
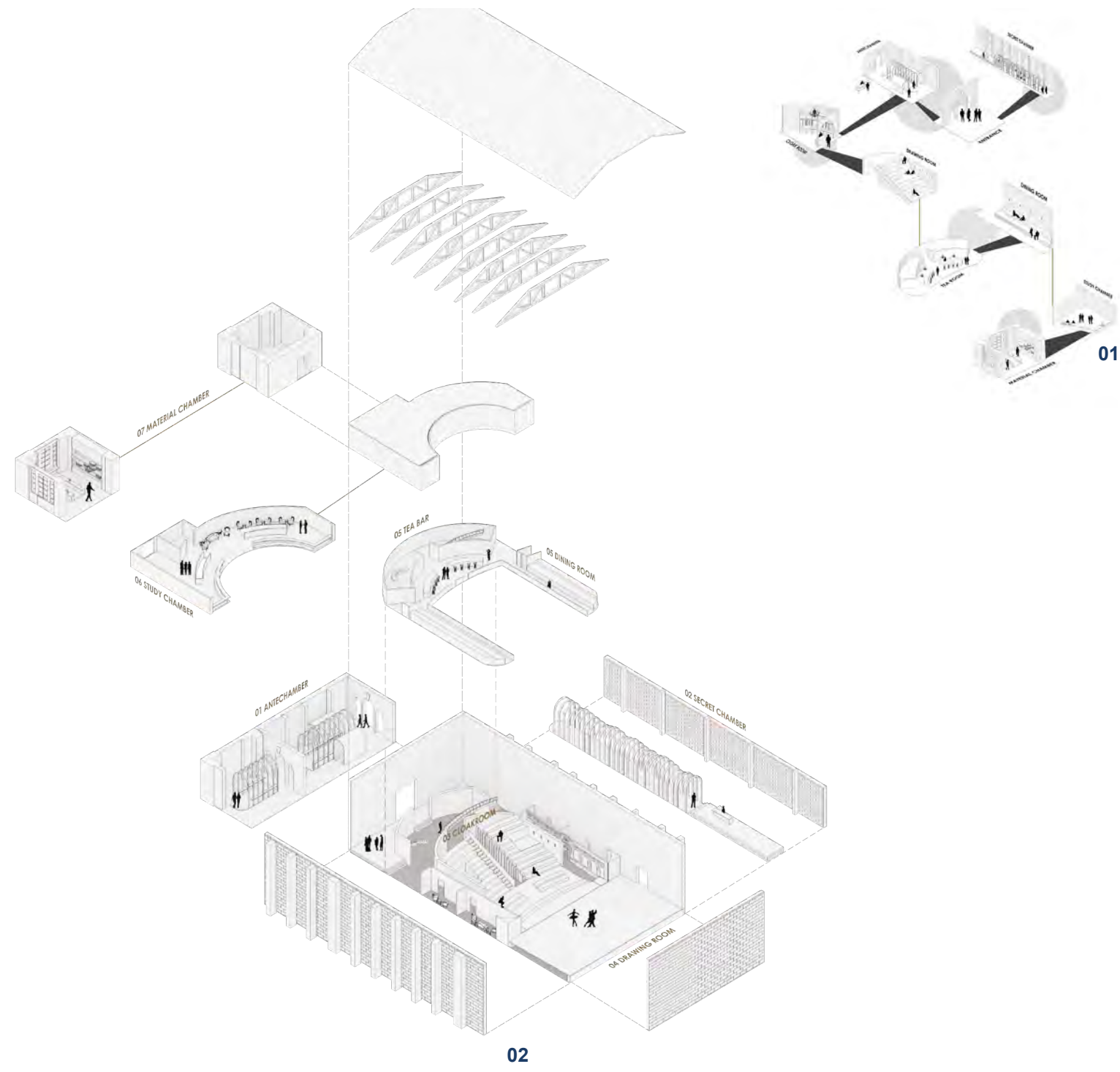

- 01 Agnes Shu Yuan Yeo
- 02 Agnes Shu Yuan Yeo
- 03 Agnes Shu Yuan Yeo
- 04 Shakera Rahman
- 05 Shiang Qian Lim
- 06 Shiang Qian Lim
- 07 Shiang Qian Lim

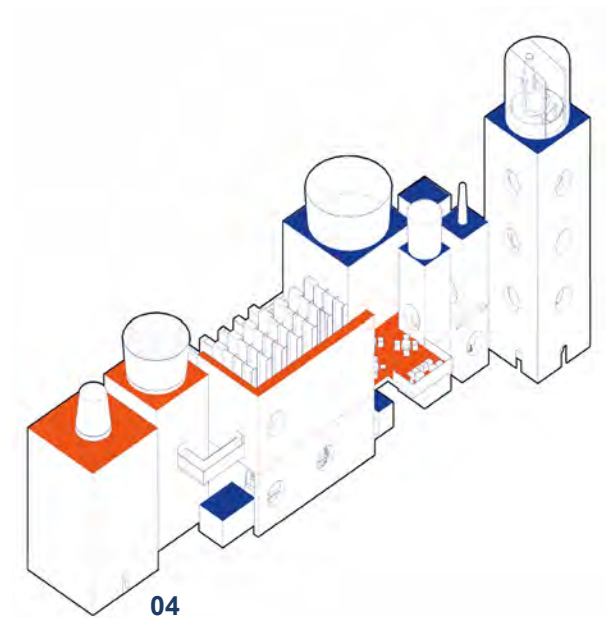
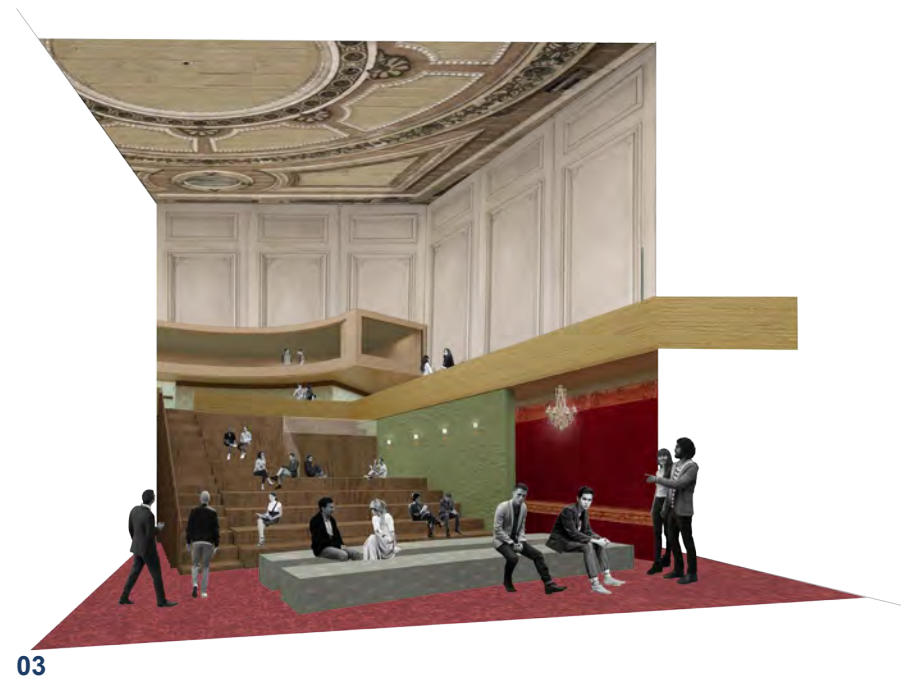

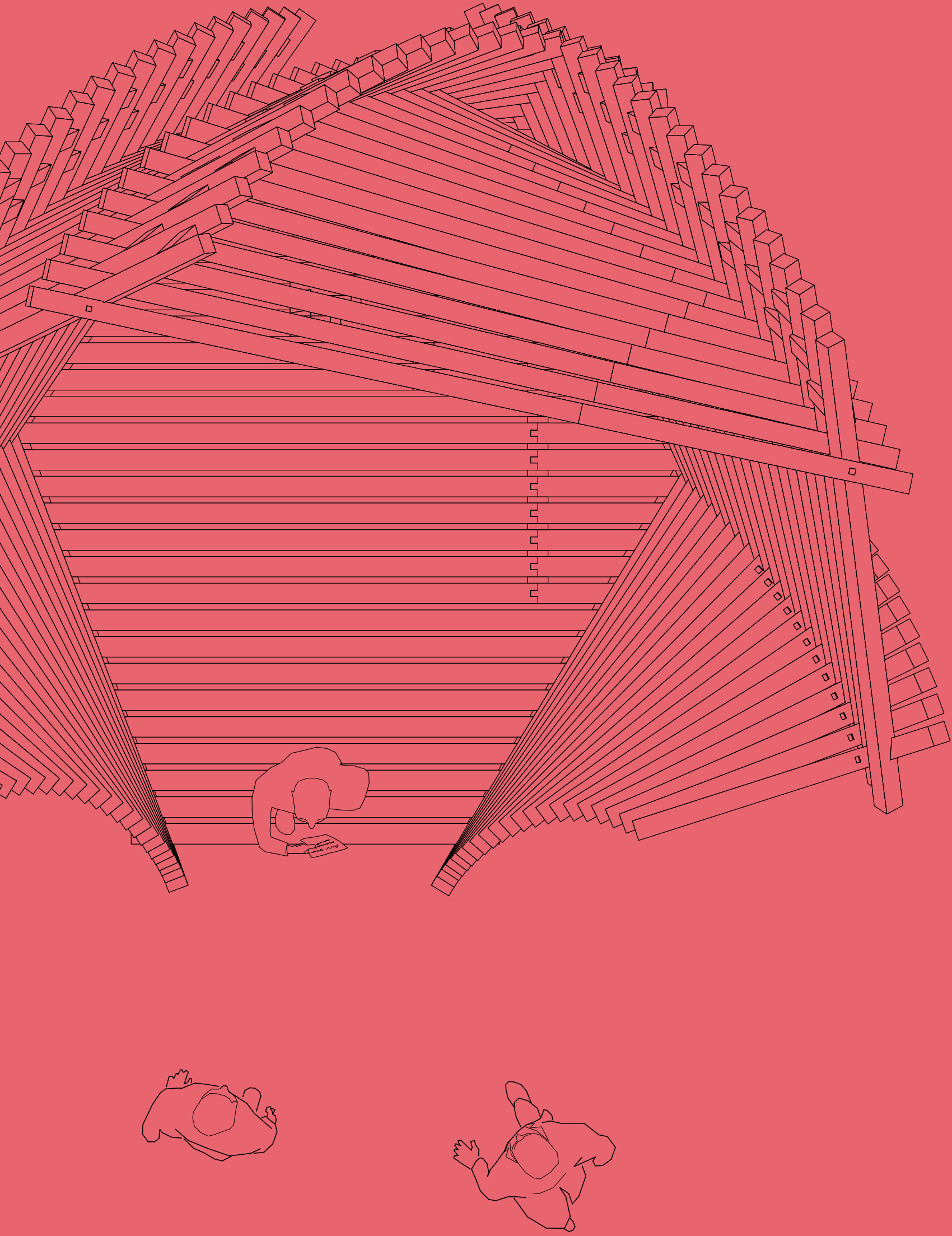

BA (Hons) Interior Design is concerned with the creation of new interiors that are inserted or installed into existing buildings or other places, relatively independent of their site contexts, for short-term use. Design projects may therefore be generic and applied to many different sites.

BA (Hons) Interior Design

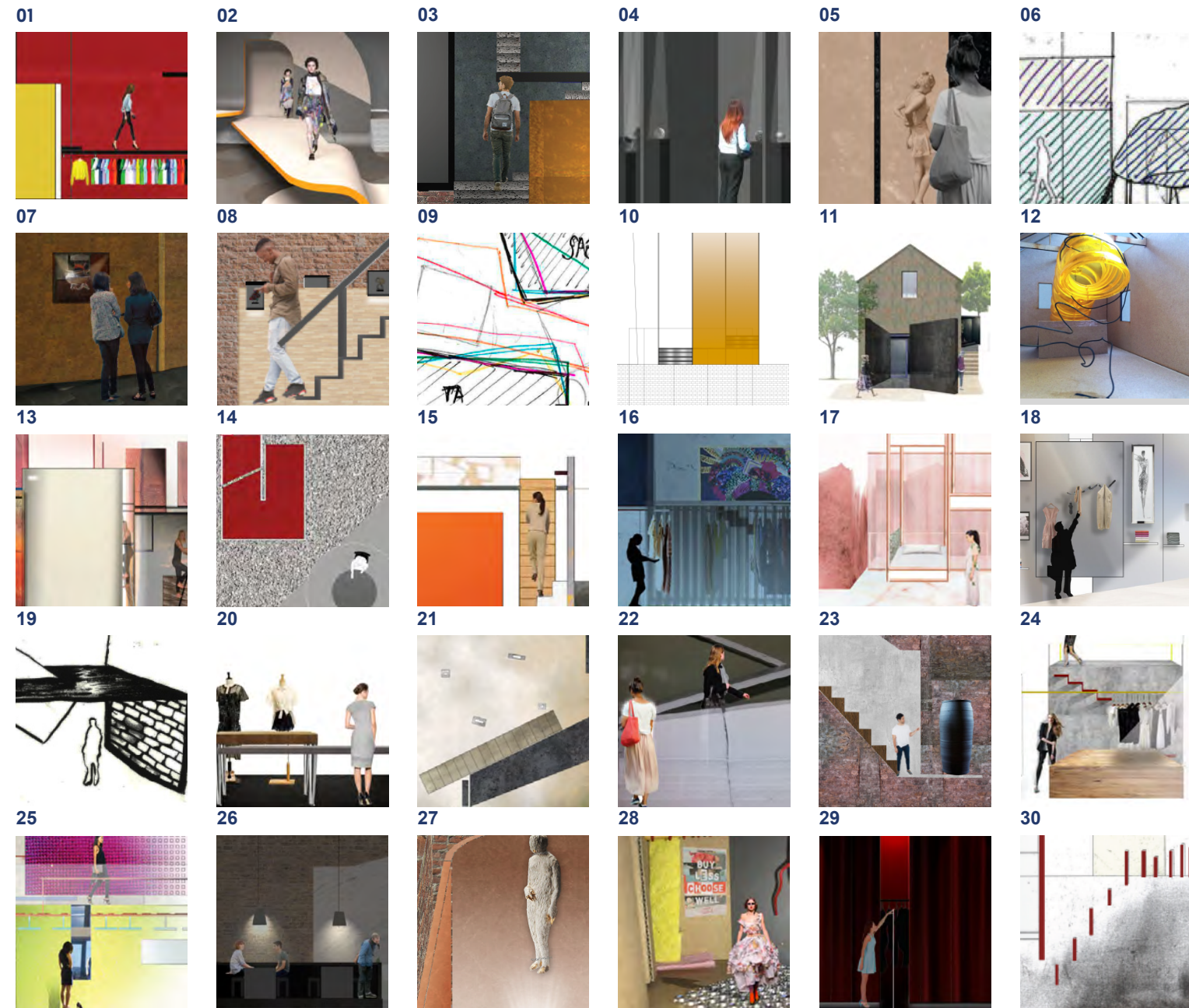

- 01 Alban Salihi
- 02 Aleksandrs Antonovs
- 03 Andreea Raileanu
- 04 Anna Ciesielska
- 05 Barbara Sofia Chiu Fonseca Lopez
- 06 Bethany Aylward
- 07 Chloe Dixon
- 08 Christine Omorere
- 09 Daniel Rui Ferreira Da Silva Reis
- 10 Derya Gul
- 11 Ida Sahlberg
- 12 Julia Keck
- 13 Klaudia Zborowska
- 14 Maha Alnuaimi
- 15 Mansi Pravin Sakhiya

- 16 Maria Gedike
- 17 Marissa Miltiadous
- 18 Melis Akpinar
- 19 Monika Maka
- 20 Mustafa Allah Ditta
- 21 Natalie Bardy
- 22 Nazifa Chowdhury
- 23 Samia Ahad
- 24 Samin Sour
- 25 Shafaq Sultana
- 26 Shannon Sutton
- 27 Temitope Allison
- 28 Yazmin Khan
- 29 Julia Keck
- 30 Shafaq Sultana

a sense of space

This project explores how a space transforms into a place through human occupancy and inhabitation. It focuses on everyday rituals and the way that we use, move through and interact with domestic, personal space. To fully understand a sense of place and relate to the needs of those we design for it is important to take human experience as a starting point.

Students were asked to design a live/work space within the Ritterman Building for three 1st year fashion students. The space needed to provide a place to sleep, a place to eat and a place to socialise. Also included should be a place for the students to work and somewhere for them to showcase their work. The space was to be sponsored by a famous fashion designer with the requirement that it should inspire, provoke, challenge and excite the imagination with a sense of the rebellious.

a place for identity

Students were required to design an exciting and impactful new interior within the historic Brunel Engine House in Rotherhithe. A permanent gallery/exhibition space was required to display the work of a given contemporary designer/maker. The space would be open to the public and include a refreshment area.

The strong character of the historic building needed to be understood and then repurposed to create an innovative new interior with an identity, atmosphere and personality that was responsive to the work of the individual designer/maker. This required an understanding of the maker's conceptual approach, the techniques and materials used to create the work and the character and identity of the pieces to be displayed.

- 01 Klaudia Zborowska
- 02 Andreea Raileanu
- 03 Andreea Raileanu
- 04 Shafaq Sultana

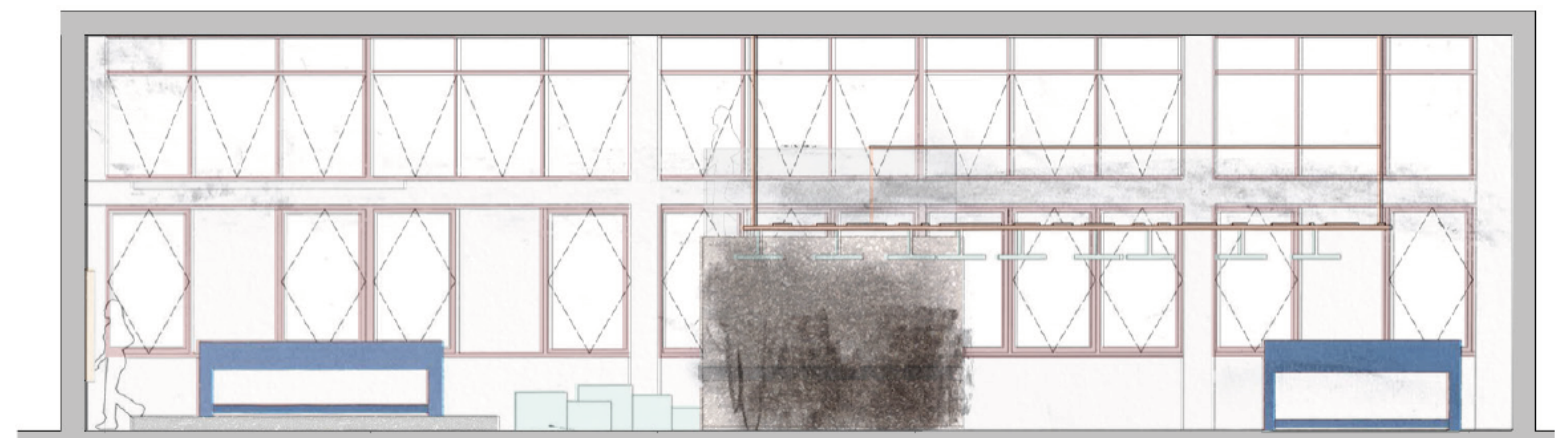
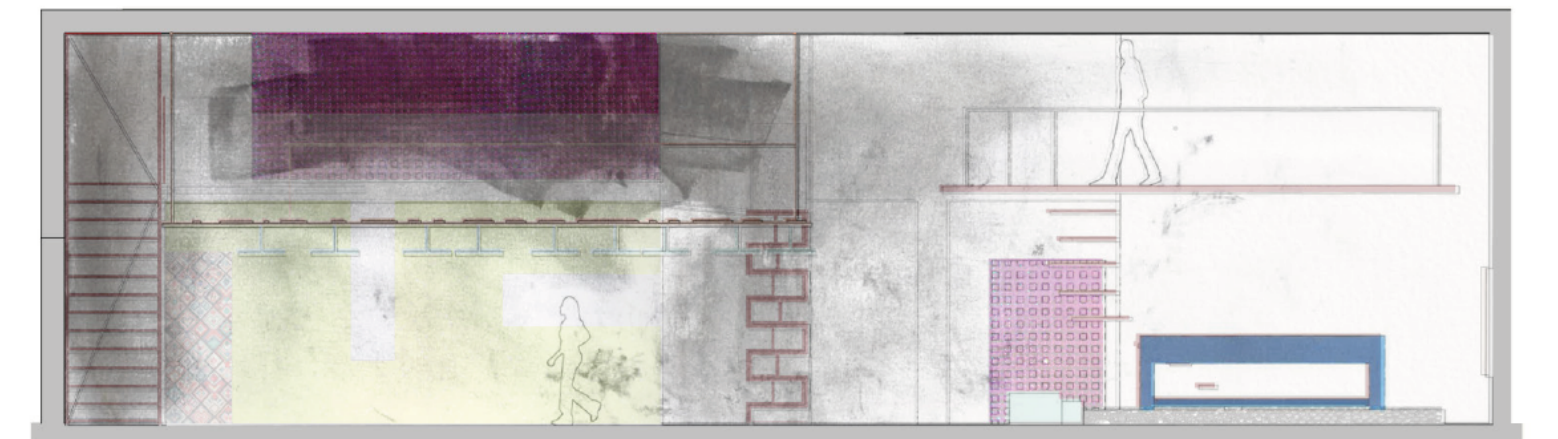
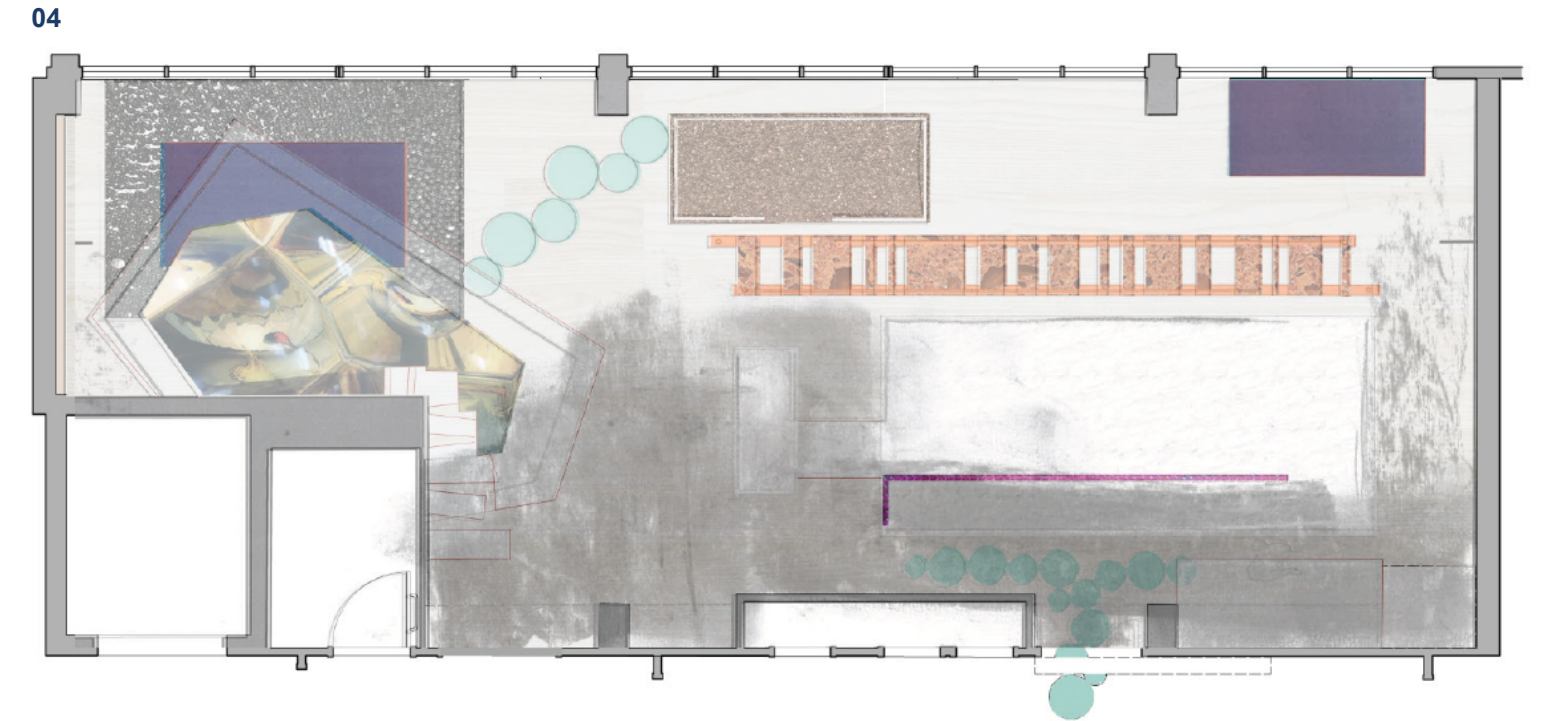
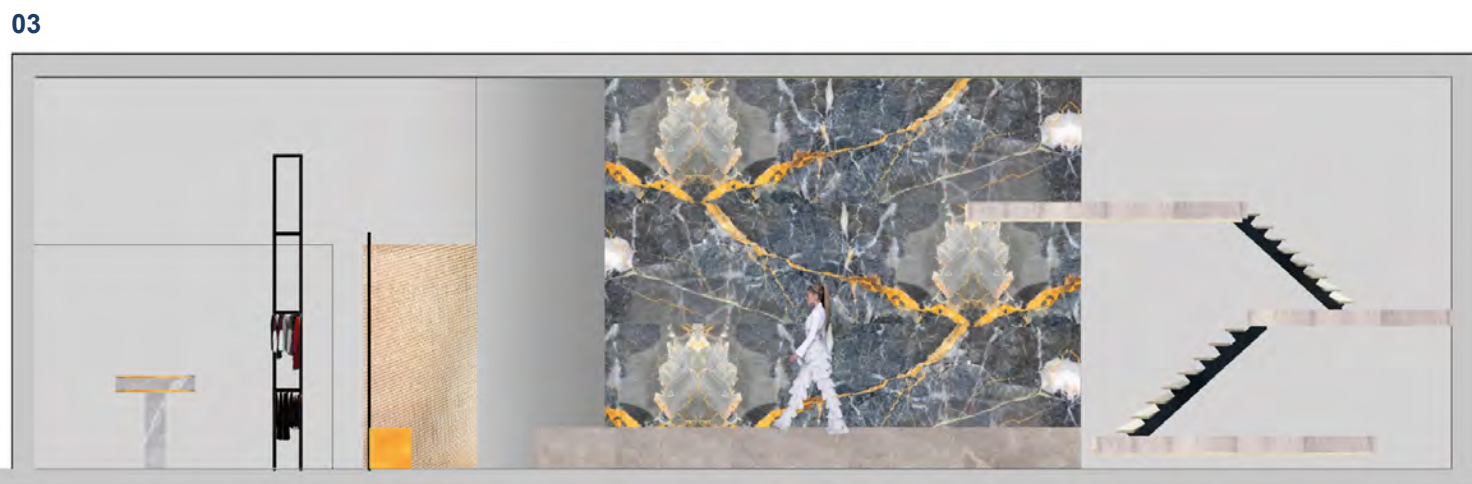

01

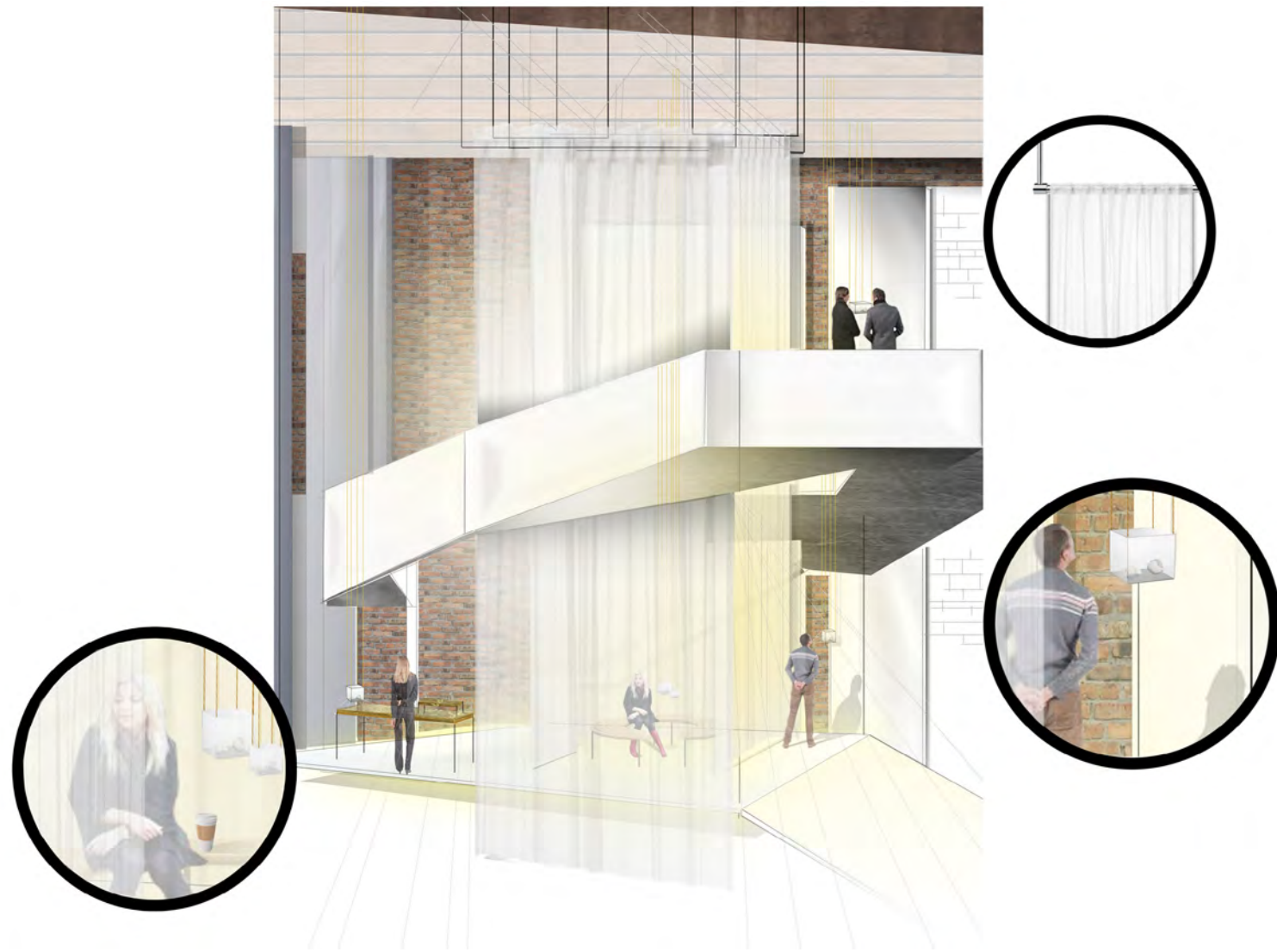

02

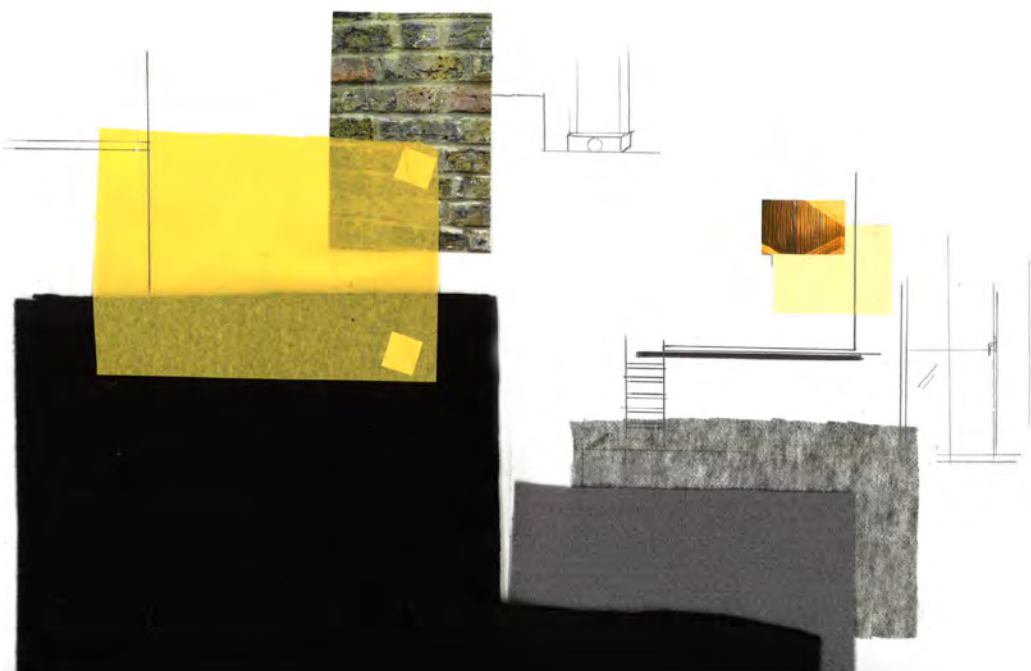

03



04

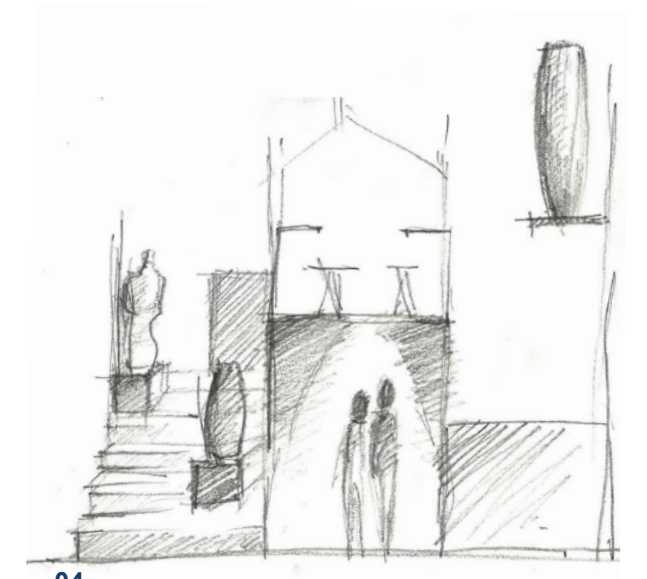

05



- 01 Klaudia Zborowska
- 02 Klaudia Zborowska
- 03 Filip Jaber
- 04 Filip Jaber
- 05 Filip Jaber

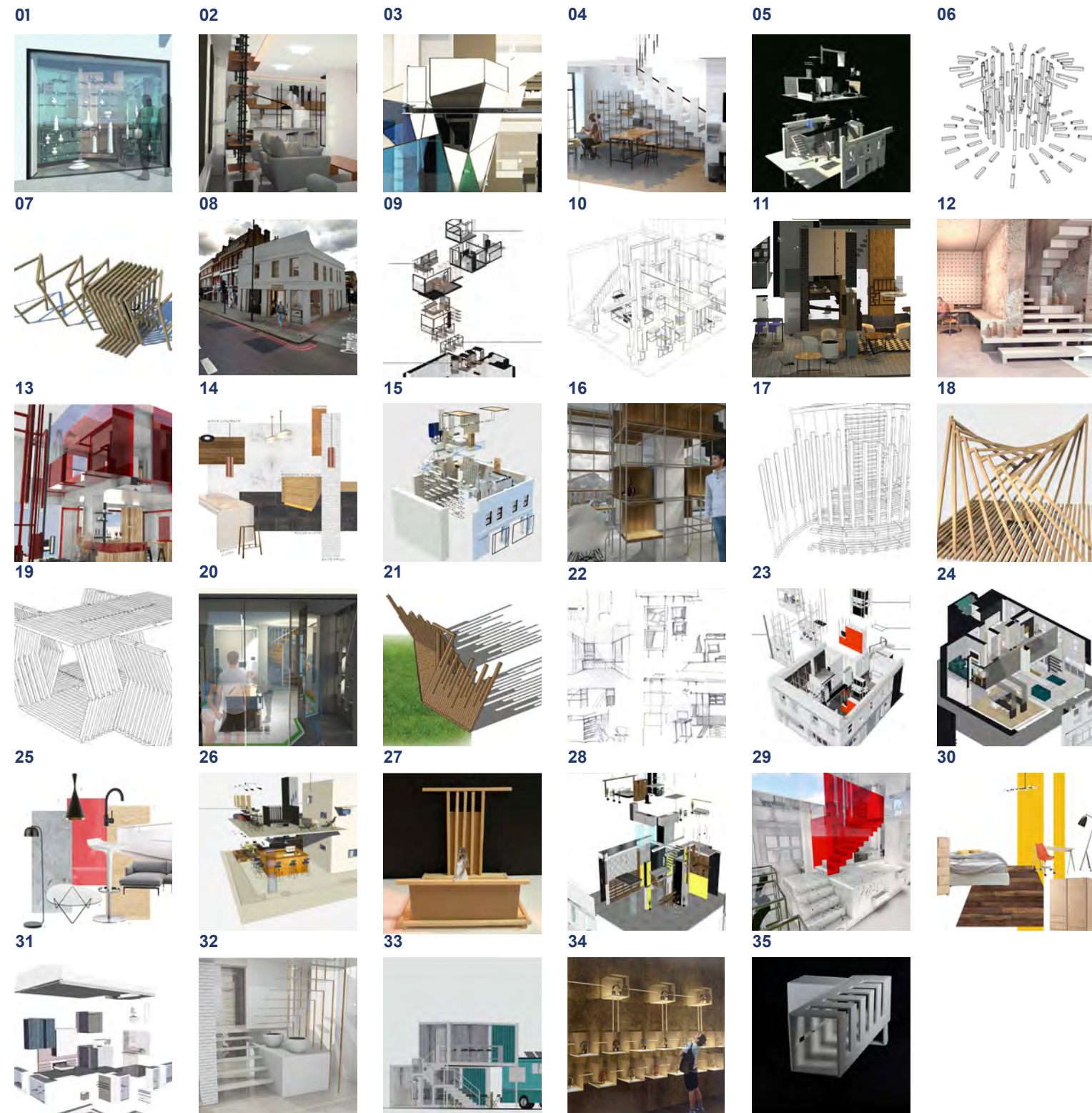

01 Steve Andrawes
 02 Joseph Hall
 03 Laila Njaimah Sarr
 04 Cristina Ariza Baeza
 05 Rochelle Sinclair
 06 Weronika Jadach
 07 Stephan Cagalj
 08 Geraldine Lopez
 09 Georgia Barton
 10 Irina Goldtmane
 11 Lera Nabokina
 12 Victoria Turcan
 13 Rahma Yusuf
 14 Talia Singer
 15 Kaileigh Harewood

16 Jovita Dabasinskaite
 17 Emanuela Buiza
 18 Sadia Parvin Sadia
 19 Pooja Rani Kaur
 20 Lara Sodan
 21 Dami Matiluko
 22 Jana Veselova
 23 Hayley Forta
 24 Savanah Hyland
 25 Gizem Yavuz
 26 Ala Moskal
 27 Alexandru Miron
 28 Viktoriya Venetsieva
 29 Soma Afrazikalvir
 30 Toni Paneva

31 Anisha Uddin
 32 Laurine Lalande
 33 Dilem Gunes
 34 Folasade Lanihun
 35 Emilia Comanescu

Poetry Performance Pavilion

Design impacts on how people react, move and respond. Design can make people stop, look and listen, it can 'announce' something important, it can 'amplify' the meaning of the subject, it can create a 'focus' and an 'identity'.

Every designed object has a 'materiality' generated by the personality and character of the materials that make up that object. Often designers believe that the choice of the material is enough to 'project' this personality but the reality is that the detailed used of the material is more important than the material itself, especially the points where materials meet and touch.

Context:

A Japanese Performance Poet is coming to tour London, their specialism is Haiku, a condensed form of poetry which uses very few words to plant an idea, like a seed, in the mind of the listener. The students have been asked to design a Performance Pavilion that has two basic needs, to encourage the public to stand and listen to the Poet, and to give the Poet a place to write 'live' Poetry which responds to the people around them and the experiences that they have. The Poet believes that the intricate precision of Haiku Poetry is related to the traditions of Japanese construction techniques, specifically traditional timber joinery, where beautifully complex carved timber joints are used to connect timber beams in the construction of temples and homes. To support

this idea a team of traditional trained Japanese joiners (timber workers) has been brought in to construct the Pavilion. The Poet does however want these 'traditions' to be interpreted in a contemporary 'London' way, with an exciting 'modern' form to attract the passers-by.

A UK timber supplier has been approached and a deal made for the supply of 160 oak beams, 2800mm long, 100x100mm square.

You will be able to also use 2 pieces of OSB Board (oriented strand board) 2400mm x 1200mm, and a piece of waterproof fabric material, 4000mm x 2000mm.

The Pavilion should be transportable, being able to be built in a day, stand for a week in a particular location, then move to a different location – these locations will be mostly interior but could be exterior. It is hoped the you will be able to use the inspiration of Japanese timber construction to create a visually interesting construction where its 'joints' are part of the understanding of the overall form. This limited range of materials is something that the Poet believes best relates to the creation of Haiku Poetry, with its limited used of words.

Melting Point

'Melting Point' Starter Studio: A Live/Work space for a craftsperson/maker where the public are encouraged to enter and explore the lifestyle of a 'creative'.

Your client, Melting Point, wants to create a 'Starter Studio' for contemporary craft in a two-storey building in Islington's Upper Street. Here a young craftsperson/maker, fresh out of university can live, make and sell their work, and in doing so promote a positive lifestyle of creativity and craft. Importantly, Melting Point want the public to engage with the maker, to visit the space and see not just how things are made but how they might benefit from individually made, creatively inspired objects in their own lives. Melting Point wants to help young craftspeople/makers to connect with the public and in doing so to allow the public to appreciate and learn from a creative lifestyle.

You are to design a live/work space that has two equally important abilities – to help support creative makers in the promotion of their work – and to help the public to engage with contemporary, individually made objects and items, seeing them as an exciting and inspiring way of adding individuality to their own lives. You will include facilities for a craftsperson/maker to live (sleep, eat, cleanse, socialize) and work (workshop/studio space) and display their work and the work of other local makers (exhibition/

gallery). The space could include something to attract passersby (café?), and a small meeting space for other makers to arrange meetings with potential purchasers of their work. The individual maker will change from year to year, perhaps a silversmith, the first year a ceramicist the second – so the workshop/studio will have equipment in it that will change.

The site is not large so careful consideration for its use will be required. The maker lives within the building and the client wants the public to learn something about their creative lifestyle by seeing how the maker lives – this brings opportunities and complications. The 'obvious' layout allows for shop/exhibition/café on ground floor; with a studio/workshop that the public can look into, with 'living' on the upper floor – but does that 'fit' within the space provided, and can you challenge this 'obvious' and traditional arrangement? Try to find an engaging and interesting way to arrange the functions of the space and in doing so to provide the public with a more interesting 'journey' through the space, and the resident makers with a inspiring place to work and live. You must 'motivate the maker' and 'inspire curiosity in the public' – two equal goals. As the public move through the spaces you create they should see, feel, hear the seductive urgency of the 'made' object (rather than the manufactured object).

01

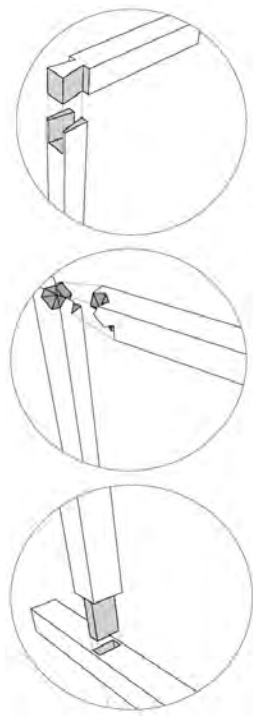

02

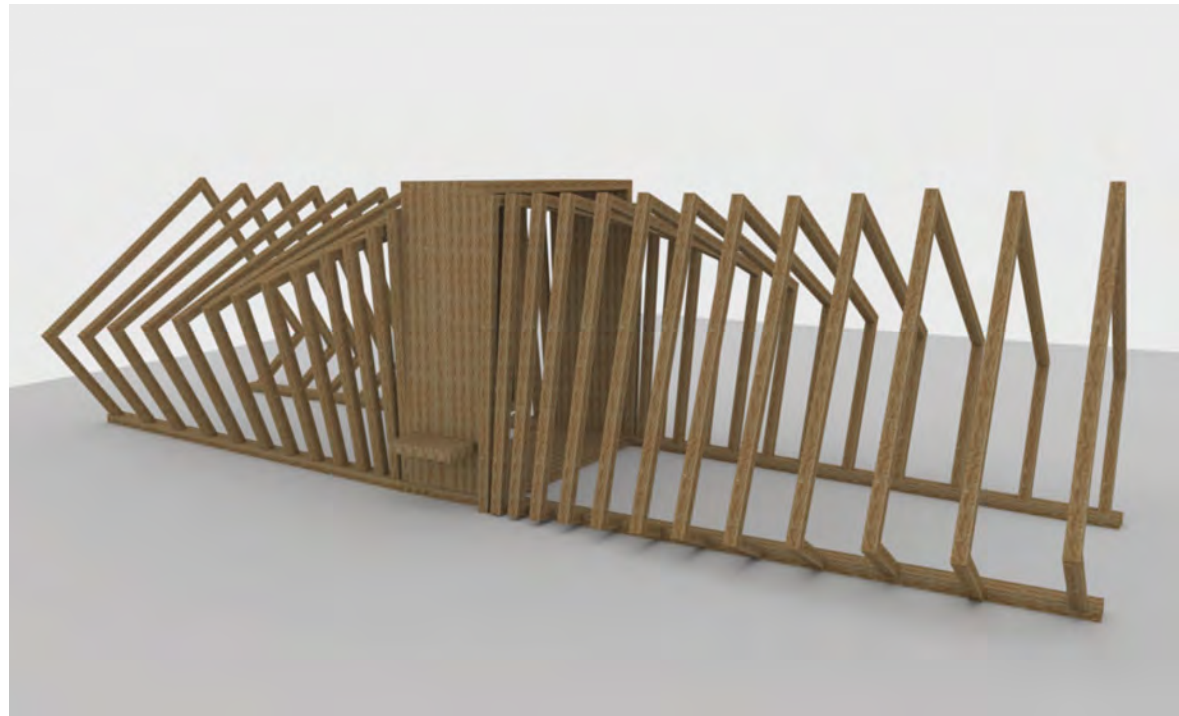

03

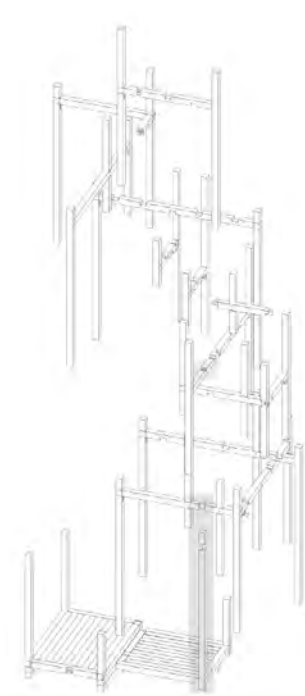

04



05

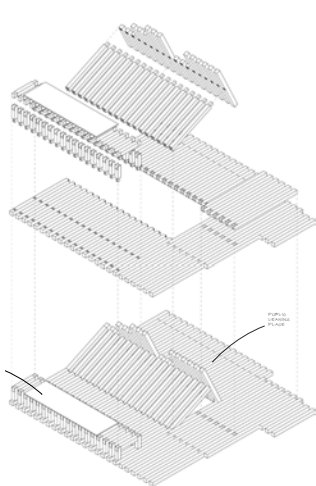

06



07

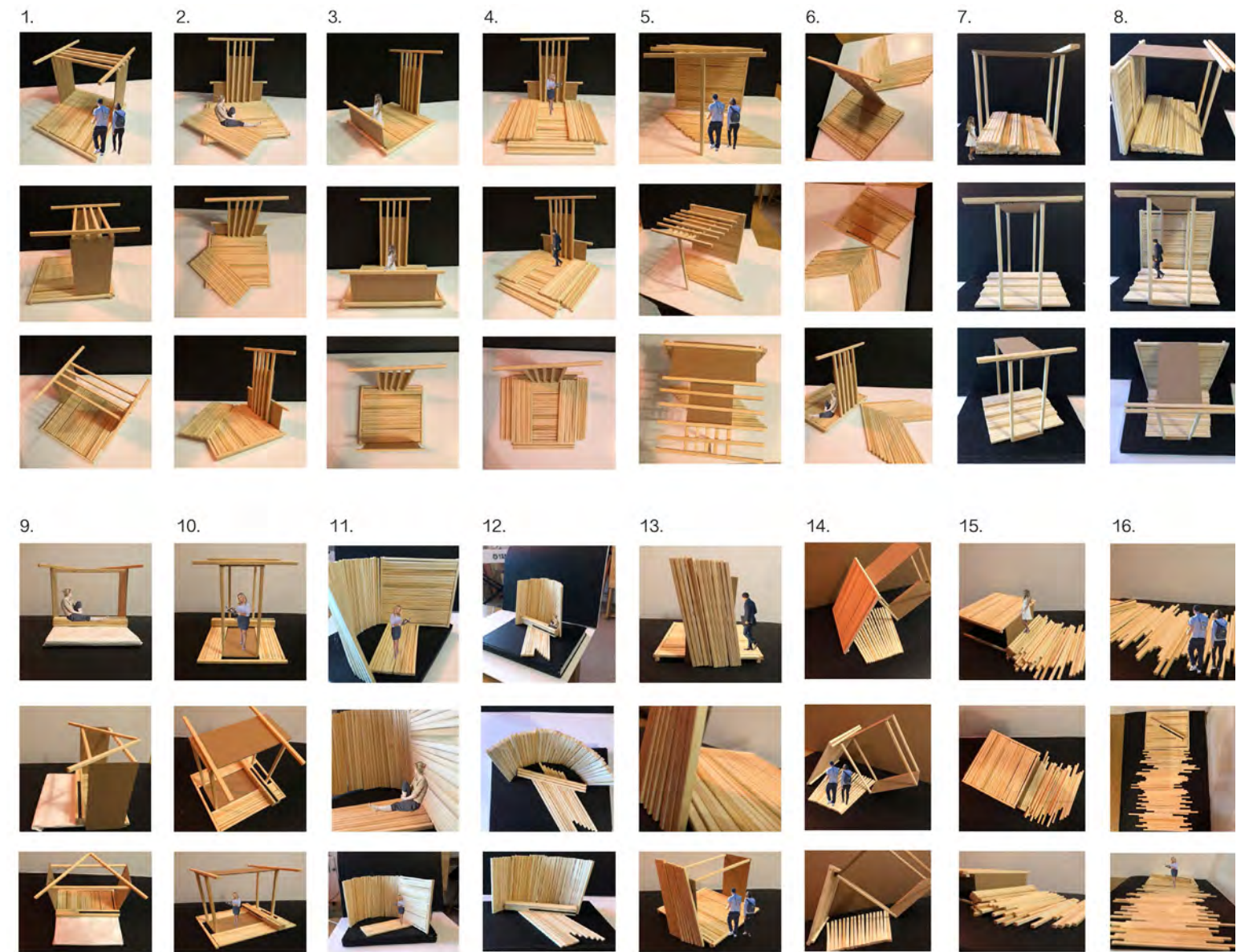

07

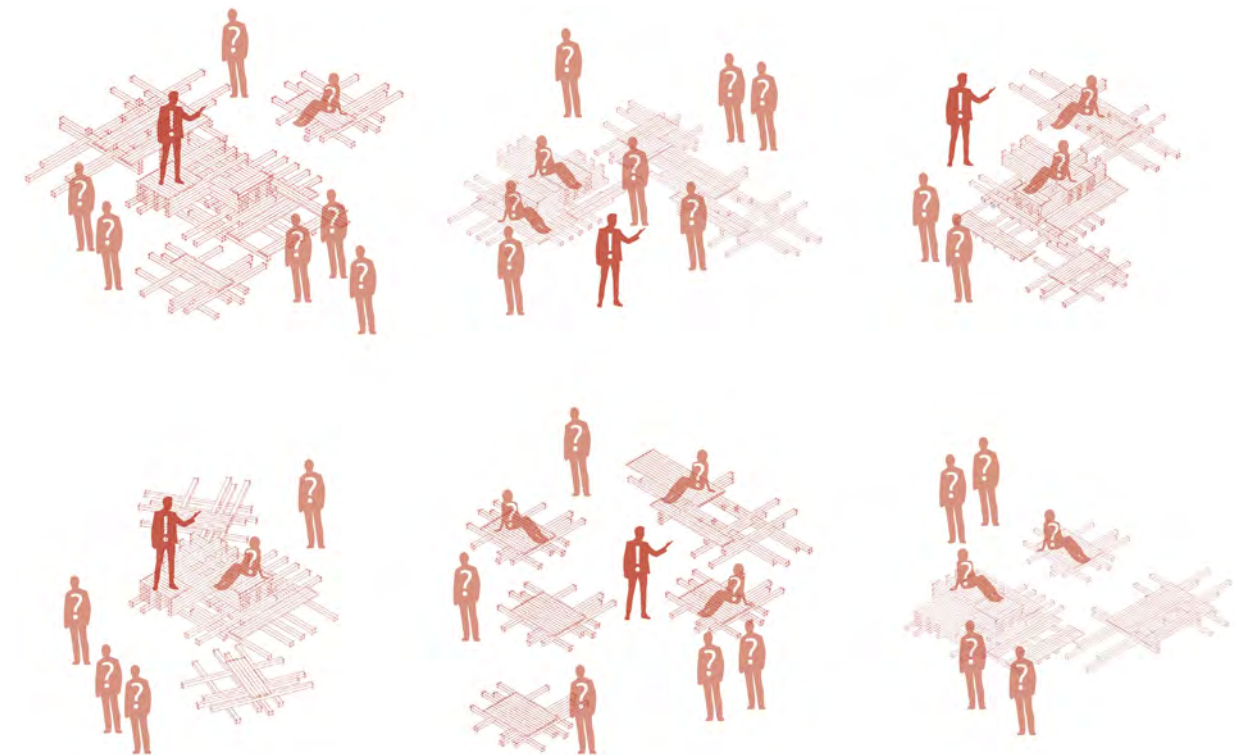

- 01 Gizem Yauz
- 02 Gizem Yauz
- 03 Georgia Barton
- 04 Georgia Barton
- 05 Irina Goldmane
- 06 Irina Goldmane
- 07 Alexandru Miron
- 08 Joseph Hall

01

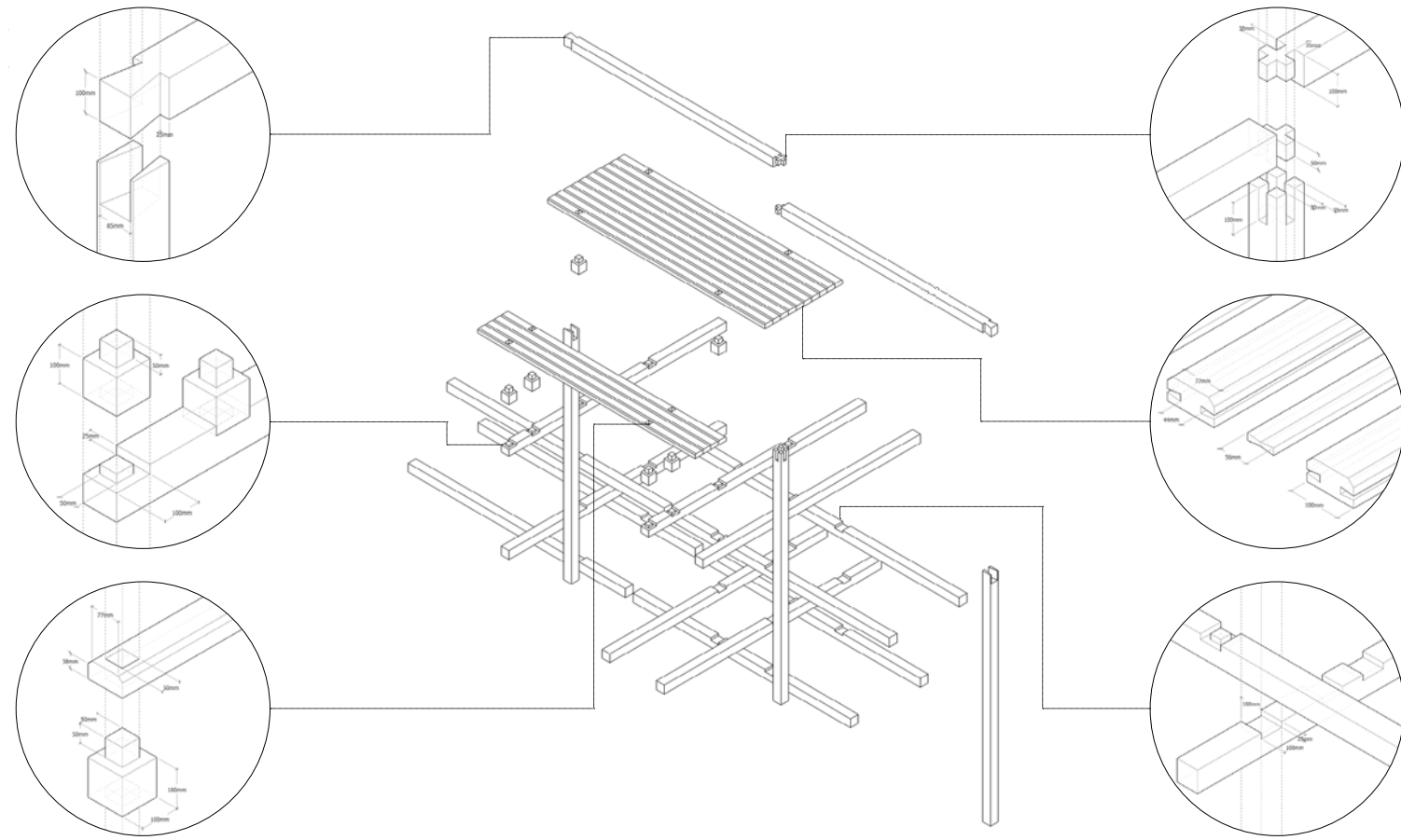

02

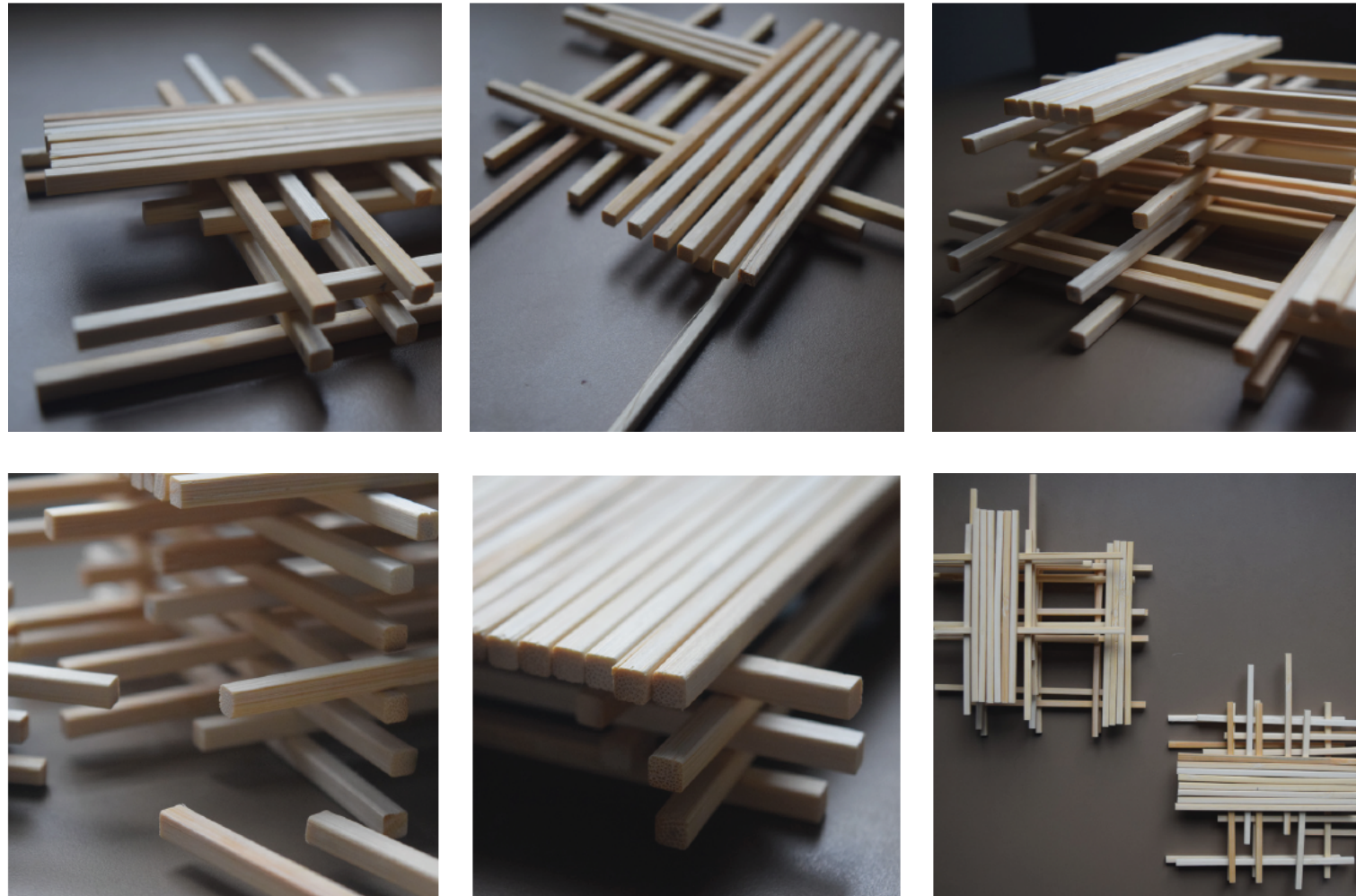

03

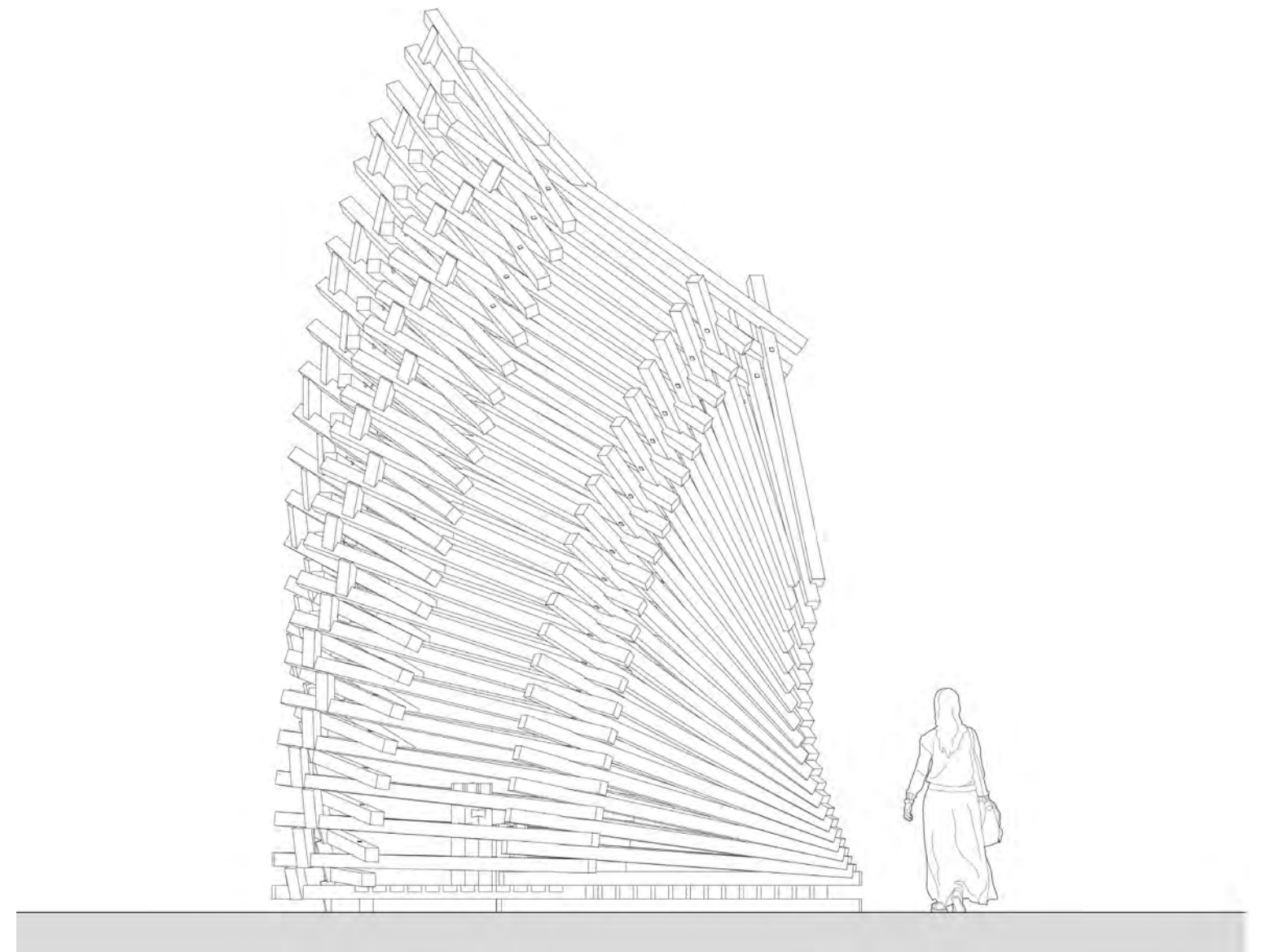

01 Joseph Hall
 02 Joseph Hall
 03 Steve Andrawes
 04 Steve Andrawes
 05 Steve Andrawes

04



05

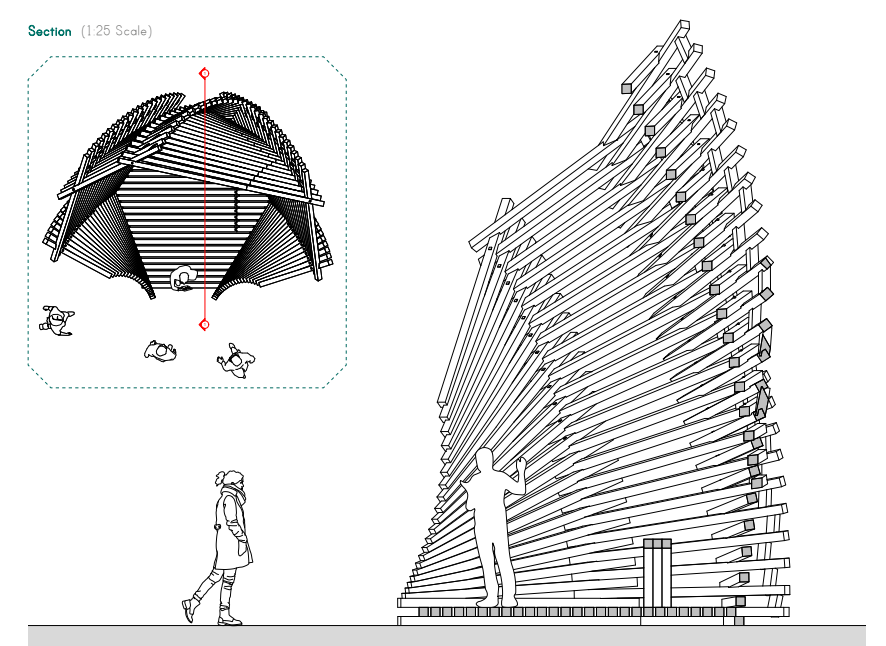

01

**FIRST FLOOR
MELTING POINT**
The general view of the first floor, where we see the artist's work area, a cafe for visitors and a forklift for general use.



02

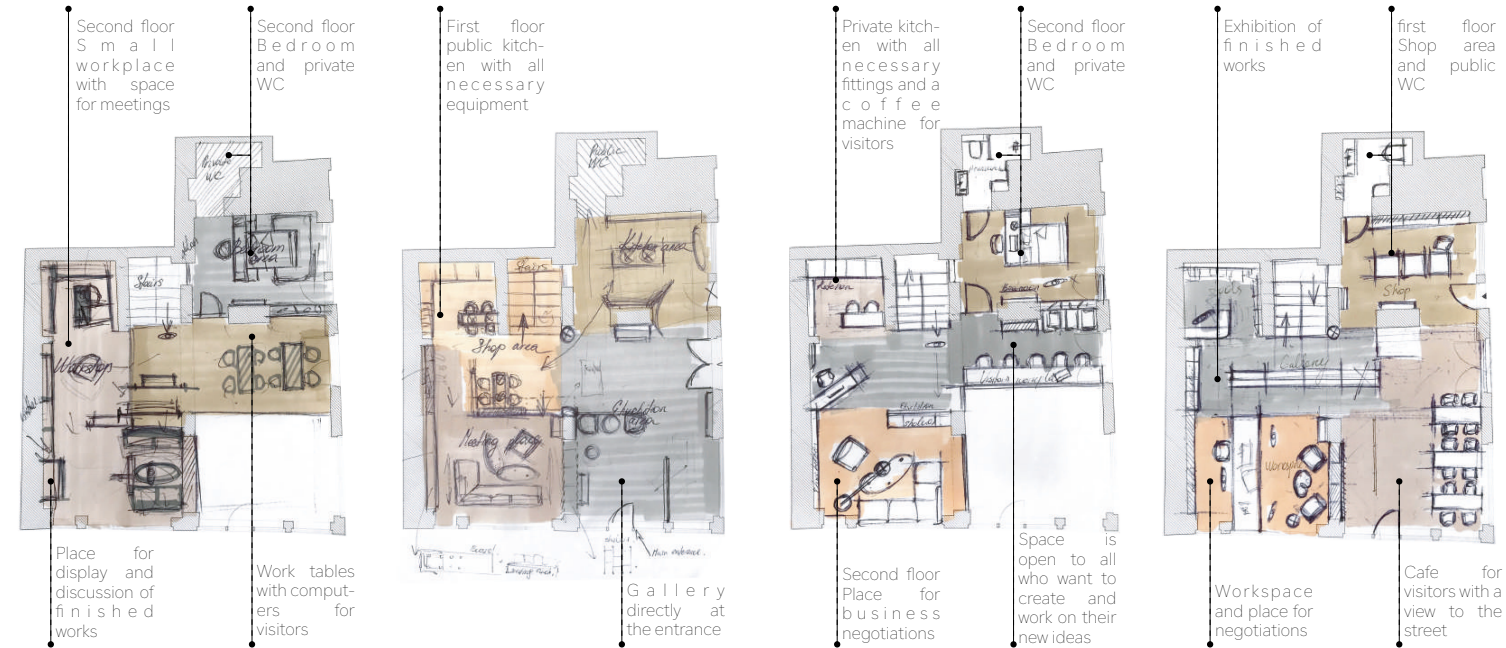

03



04



- 01 Jana Veselova
- 02 Jana Veselova
- 03 Joseph Hall
- 04 Taila Singer
- 05 Gizem Yavuz
- 06 Jovita Dabasinskaite
- 07 Geraldine Lopez

05



06



07



01



02

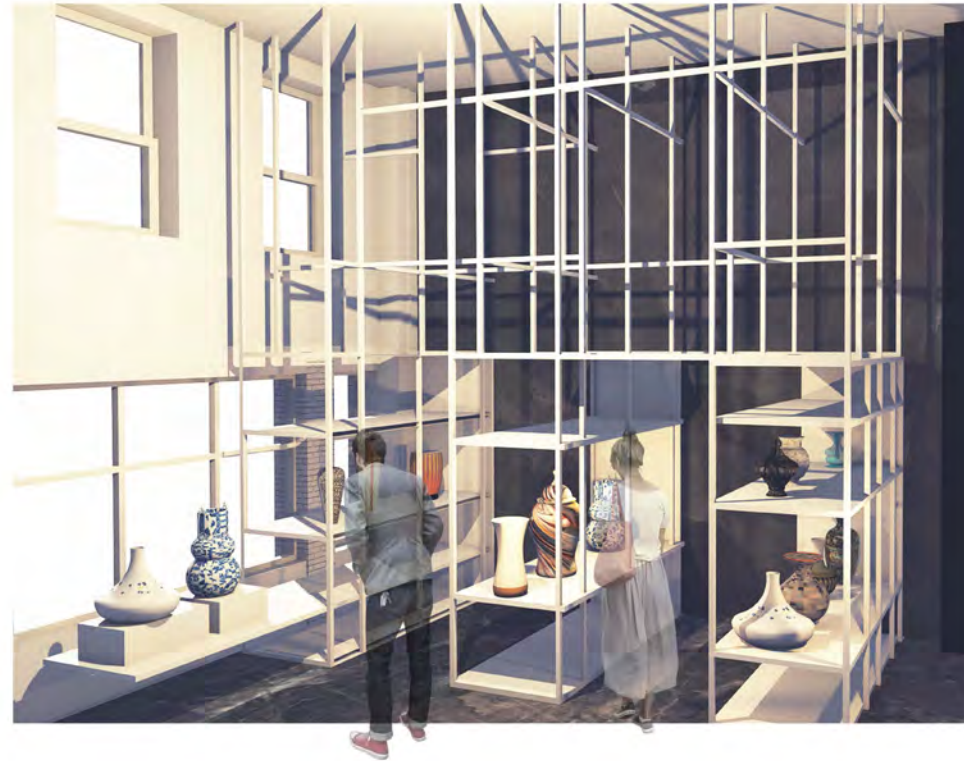

03



04

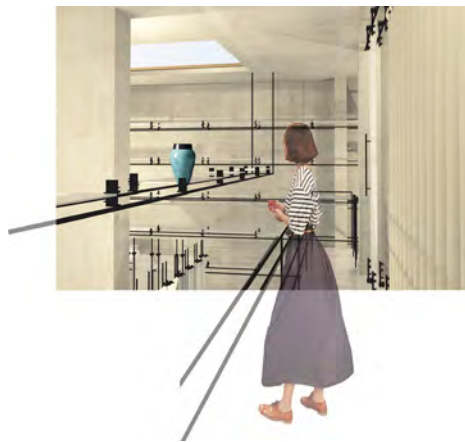

05



06

07



08



- 01 Hayley Forta
- 02 Hayley Forta
- 03 Antoniya Paneva
- 04 Kaileigh Harewood
- 05 Antoniya Paneva
- 06 Laurine Lalande
- 07 Jana Veselova
- 08 Georgia Barton

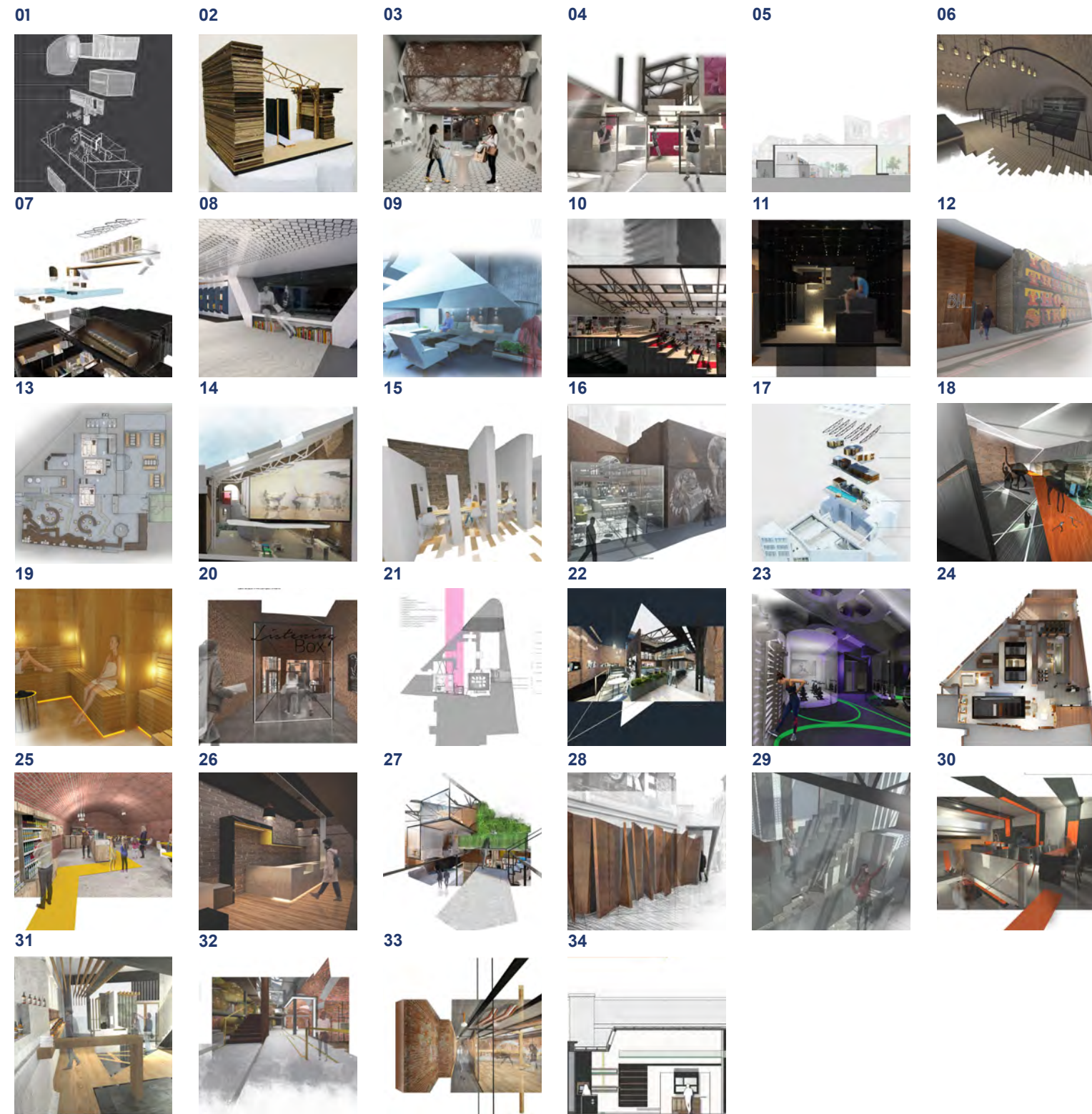

- 01 Aneesah Masoud
- 02 Anitha Kamalanathan
- 03 Hafsa Mariam
- 04 Aleksandra Kmiecik
- 05 Alicia Mae Waknell
- 06 Angela Bonetti
- 07 Anita Rai
- 08 Anwar Omer
- 09 Erna Sejdivic
- 10 Estefania Becerril Hernandez
- 11 Gabija Viliute
- 12 Hanna Stauch
- 13 Helen Dang
- 14 Ja Hkawn Kumje
- 15 Kin Lok Lau

- 16 Kotryna Skrickyte
- 17 Leah Brewster
- 18 Milana Milcanovska
- 19 Mohanapriya Mahendran
- 20 Patricija Gadliauskaite
- 21 Priscilla Rizzieri
- 22 Roxanne Stone
- 23 Silvia Jagdey
- 24 Vaad Asl Sharhani
- 25 Victoria Kilypaite
- 26 Cheuk Fung
- 27 Daniela Hurmuzache
- 28 Juste Keliuotyte
- 29 Jessica Meyers
- 30 Karolina Kwiatkowska

- 31 Kelsey Dorrian-Godfrey
- 32 Valentina Brughera
- 33 Valerie Akano
- 34 Zhane Smith

designing for our future selves



Age longevity is one of the greatest achievements of the modern era, however the ageing population is a major concern for governments around the world. Although we are living longer, we are not necessarily living healthier, or more active lives. Improving the quality of life among older people, while managing chronic diseases and conditions, will challenge us as individuals, families, health systems and administrations for the foreseeable future.

Many people are concerned about ill health. Research shows the many benefits of exercise, social interaction, maintaining a healthy diet, sleep, as well as the early diagnoses of conditions, as the key contributing factors of feeling healthier for longer. The market for products and services which help you look and feel good has rocketed in recent years. The annual sales in beauty products alone, in the UK, are in the region of £4 billion. Medical advice to stop smoking, exercise and eat less, has led to more and more of us 'looking after ourselves', or at least trying to. Whilst we know we have every chance of living longer, many of us are doing something in our earlier life, to try to stay healthier for longer. How do we design environments which inspire us to make a change in our lives? How do we design to help our future selves?

The population of the UK is ageing. In 2014 the median age of the UK population exceeded 40 for the first time¹. By 2040, it is predicted that nearly one in four people in the UK will be aged 65 or over². The number of people aged 65+ is projected to rise by over 40 per cent in the next 17 years, to over 16 million³.

1,3. Government Office for Science. (2016). Future of an Ageing Population, v3, London, Foresight.
2. Age Concern. (2017) Later Life in the UK.



The year's projects are sited in two adjacent buildings, a shop unit currently occupied by a hairdresser and Village Underground, a live venue and temporary rental space. The sites are located in Shoreditch. The students could explore the dual aspect of both sites, one façade on Holywell Lane and the other on Great Eastern Street. The relative quietness of Holywell Lane and the cacophony of noise generated by Great Eastern Street, was a factor in how the students orientated their physical approaches.



Photograph of Tom Broughton, founder of Cubitts, with our students. L-R Hanna Stauch, Vaad Asl Sharhani, Anwar Omer, Tom Broughton, Roxanne Stone, Rosa Angela Bonetti, Daniela Hurmuzache.

Project One saw the students designing retail environments, which help advance the role of design in promoting health. Shops, which dealt with food, sight, memory and skin, all had a diagnostic element contained within them. Here customers could consult a professional about their health concerns and seek advice about how to make alterations to their existing lifestyles. The idea of consultations being available on the High Street, within retail environments, could be problematic, however it does increase the likelihood of early diagnoses, one of the key objectives of the project scenario. The existing building is a 'fill in' space, a structure strung between to larger, heavier edifices. Students reacted to this transient feel, largely creating projects that were installations, which kept in mind the 'roll-out' nature of retail. The student's digital models have been converted into Virtual Reality spaces, so that students and visitors to the degree show can be immersed into their schemes.

We were very happy to work with opticians & spectacle makers Cubitts as one of our imagined clients. They allowed us to visit their shop and bespoke making workshop, as well as reviewing the student's completed projects and providing valuable feedback.

While the first project was centred on health, Project Two saw the students expand their multi-sensory themes into wellbeing spaces. Working within the Village Underground, who generously allowed us access to hold a workshop in their space, the students created interventions which nourish our physical, or mental welfare. Village Underground is a site of two halves. A set of three brick railway arches form one side. They are dense, heavy structures with no natural light. The other half of the site is steel frame, light, tall with generous skylights allowing light to penetrate through the space.

The students were encouraged to engage with this intriguing space using a mixture of quick models and sketching techniques, before developing their own briefs into workable, site specific solutions. Many of the projects on display here are carefully considered solutions to our busy lifestyles. Whether they allow you to focus, exercise, relax or study, they all offer the user a form of solace from the outside world.



01



04

- 01 Karolina Kwiatkowska
- 02 Juste Keliuotyte
- 03 Juste Keliuotyte
- 04 Valerie Akano
- 05 Valerie Akano
- 06 Roxanne Stone

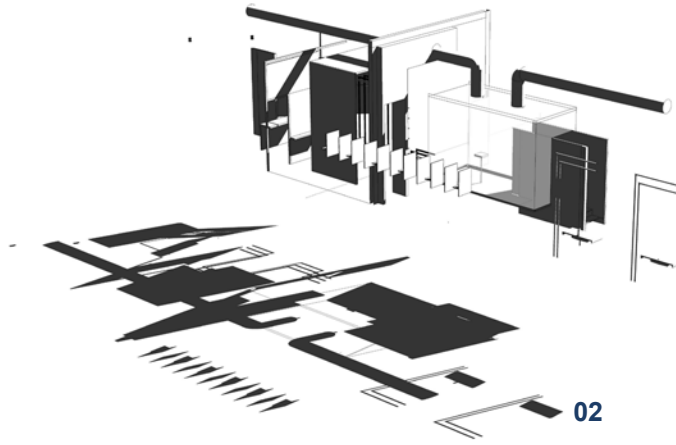

02

03

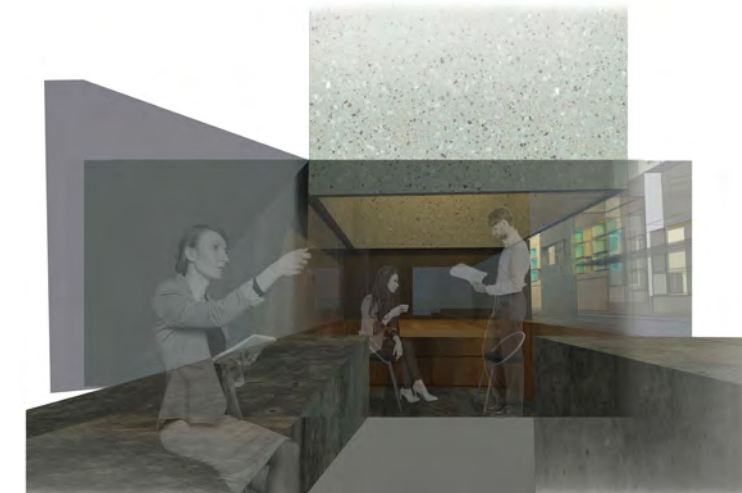

05

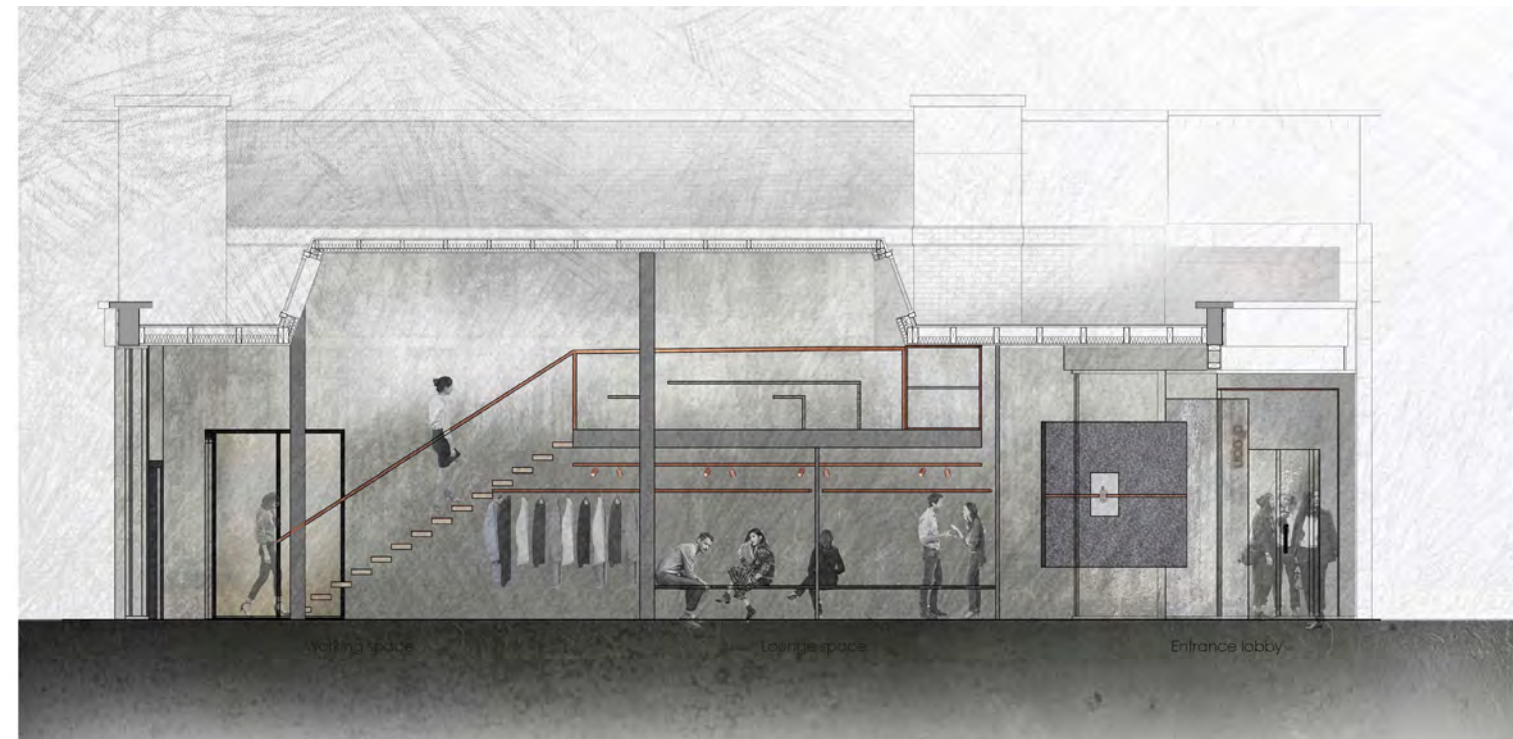

06

01



02



03

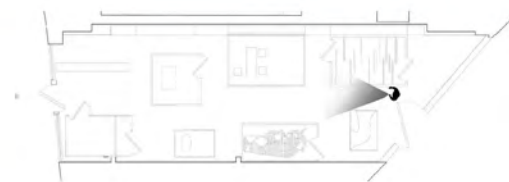
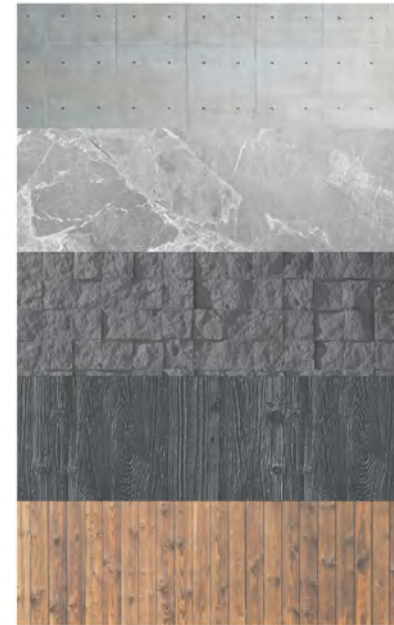
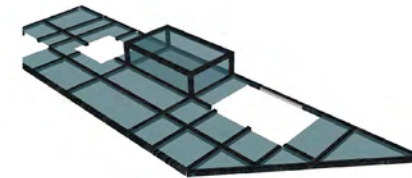

04



05



06



- 01 Aleksandra Kmiecik
- 02 Hanna Stauch
- 03 Patricija Gadliauskaite
- 04 Daniela Hurmuzache
- 05 Daniela Hurmuzache
- 06 Daniela Hurmuzache
- 07 Kotryna Skrickyte

07

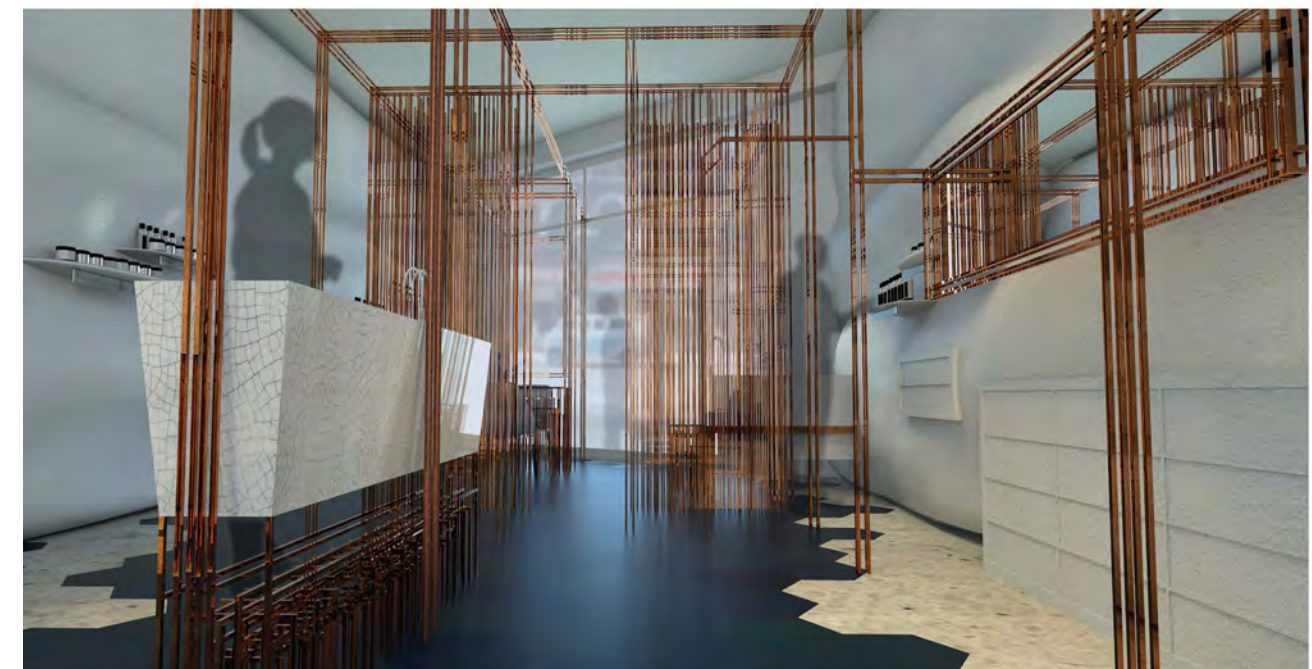

Storytelling in Contemporary Design

———— Daniel Hurmuzache

In the world of design, the role of the storyteller is taken by different elements. A direct analogy from theatre can be applied here. In existing design fields, especially spatial design, we are able to notice a merging between the space inhabited (the stage) and the user (the audience). There is no longer a clear threshold between the two; nowadays they both hold an equal importance in creating a more tangible, immersive experience. The truly great storytellers have long embraced the fact that the most powerful stories happen in the mind of the audience, making each and every story unique and personal for the individual¹. In hospitality design, for example there's a need for hotels to reflect the culture in which they are based (Sofitel Tamuda Bay, Fellah Hotel - Morocco; St.Gabriel Hotel - Beirut).

This specific approach applied in many other design branches has been transformed into a marketing tool. The art of storytelling through interior design engages travellers socially, culturally and historically, and creates destinations that are based on a shared experience between travellers and the local environment. Translating storytelling into the physical world through a hotel's interior design engages its users and connects the user to the environment in which (in this case) the hotel is located².

On another side, where plays were created for the whole purpose of educating crowds, the same analogy could be applied to retail. Although the focus here is to sell products, there still exists a need of pleasing 'the public' (customers) which can be accomplished through selling more than a 'thing' - selling experiences. Every story either found in books, plays, songs etc. has a beginning (exposition), middle (climax) and an ending³. These collective elements are what make the overall experience a lot more memorable. Directly translatable in contemporary design, one can identify these elements within a retail environment as follows:

the exposition becomes the entrance (threshold within the space), the climax, the product display/ merchandising area and the ending becomes the summary of the experience lived throughout the space (when exiting the store). This unconscious participation of the audience within the performance creates a dynamism of the story, which perfectly captures the notion of immersive customer experience.

Taking this analogy further, we could consider that the building itself is a complex character (persona) in the story of a place⁴. Paul Ring here believes that, when investigating a building, a designer must place it in a bigger context, of its location. It then starts communicating from the exterior inwards. Peeling away the layers from the outside in (like an archaeologist) the physical entity reveals itself in a complexity of details that make inhabitants connect to it even more. These users are then the next ones to take on the actor role into this holistic narrative, revealing yet another layer of a building through personal interaction with the physical entity.

¹ Galal Mahmoud -*The Storyteller – Business Architecture & Design*, p.56, *Hospitality News – March-April 2014*

² *ibid.*

³ Yutong H., Chuanhong X., *The Inquiry of Storytelling Narrative in the Museum Display Design*, *World Journal of Social Science Research*, Vol. 4, No. 2, 2017

⁴ Ring, Paul (2007) *Re use and the archaeology of storytelling*. In: *Gli interni nelprogetto sull'esistente*. Il Poligrafo, Padova, pp. 293-296.

Searching for Utopia

———— Aneesah Masoud

The word Utopia originated in the mid 16th century and was derived from the Greek words, ou 'not' and topos 'place.' The word was first used in context, by Sir Thomas More in the book 'Utopia' in 1516. According to John Carey, essentially the word Utopia "means nowhere or no-place."¹ However, many associate the word Utopia with a good place and the opposing word Dystopia is defined as a bad place. Carey also said, "To count as a utopia, an imaginary place must be an expression of desire"². And "To count as a dystopia, it must be an expression of fear"³. This piece of research looks into the so-called imaginary good and bad places of architecture during the 1960's and 1970's.

"Haus-Rucker-Co: Architectural Utopia Reloaded", Haus am Waldsee, Berlin. In the 1960's many experimental groups were formed in search of utopia, this is due to this time being a decade, which was revolutionised as counterculture and hippies became prominent.

The people of the 60's had hope and according to Co.Design, "It was a moment where it seemed like society could transform"⁴. Attitudes and values were changing, and people stopped conforming to the general norm of society. Society rejected the order and political trends in pursuance of freedom of speech; many protests were being held against issues such as "war, environmentalism, racism, and equity"⁵, and architects and designers "Saw a promise in technology and a bright future"⁶. Fundamentally, they were paralleling this divergent attitude, groups of architects and artists began questioning their beliefs, and the meaning of social norm, together they were trying to resolve current issues through design, this was, I suppose, their form of freedom of speech. Some of the most influential utopian architects and architectural groups just to name a few were Haus-Rucker-Co, Ant Farm, Cedric Price and Archigram, the similarities between them was their vision to improve the future.

¹ Carey, J. (1999). *The Faber book of Utopias*. London: Faber and Faber. p. xi.

² *Ibid.*, p. xi.

³ *Ibid.*, p. xi.

⁴ Co.Design. (2015). *What Killed the 1960s Struggle For Utopia?*. [online] Available at: <https://www.fastcodesign.com/3049039/what-killed-the-1960s-struggle-for-utopia> [Accessed 15 Jan. 2018]. ⁴ *Ibid.*

⁵ *Ibid.*

⁶ *Ibid.*

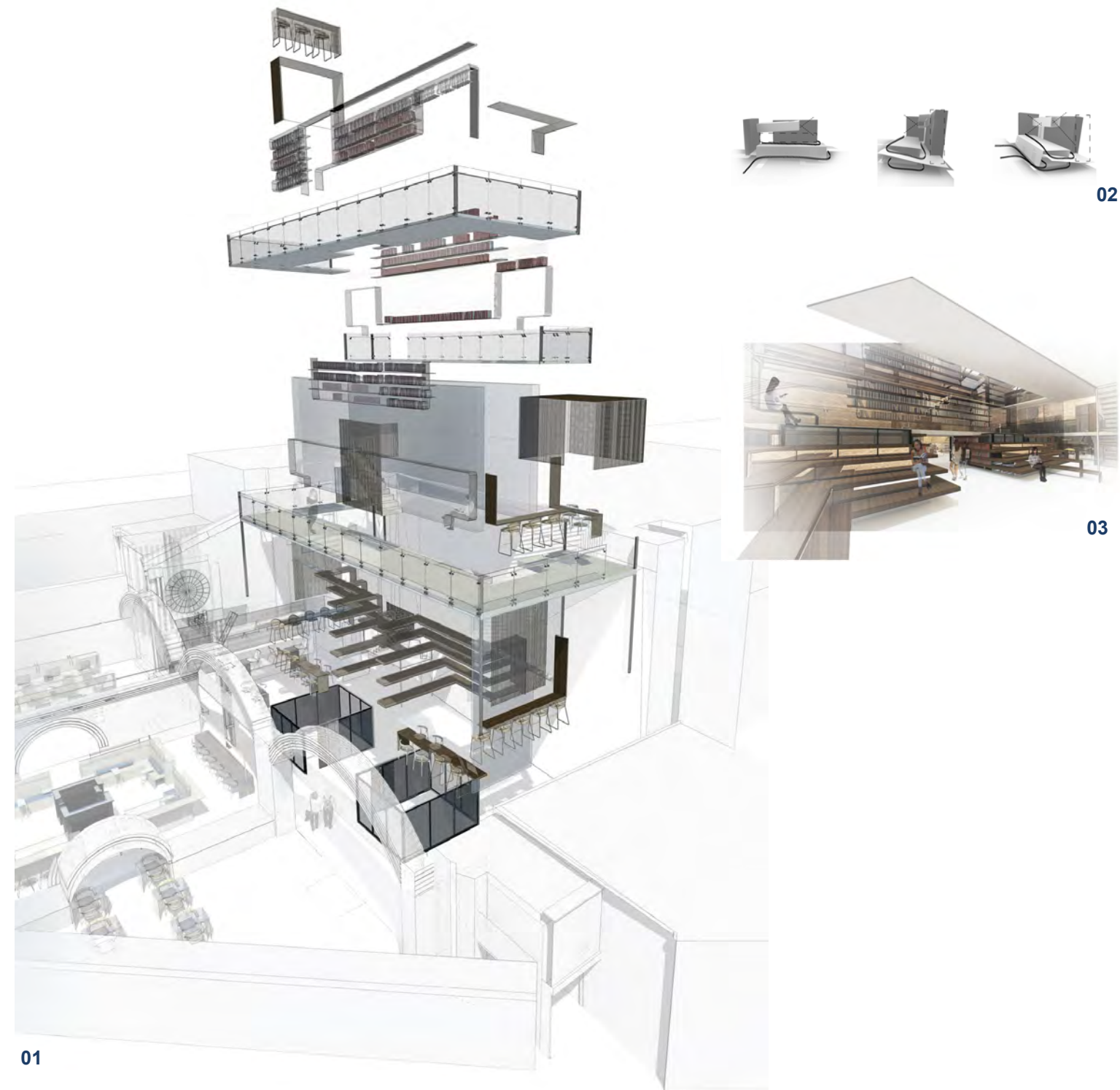

- 01 Hanna Stauch
- 02 Hanna Stauch
- 03 Hanna Stauch
- 04 Karolina Kwiatkowska
- 05 Cheuk Tung Fung
- 06 Daniela Humuzache
- 07 Daniela Hurmuzache

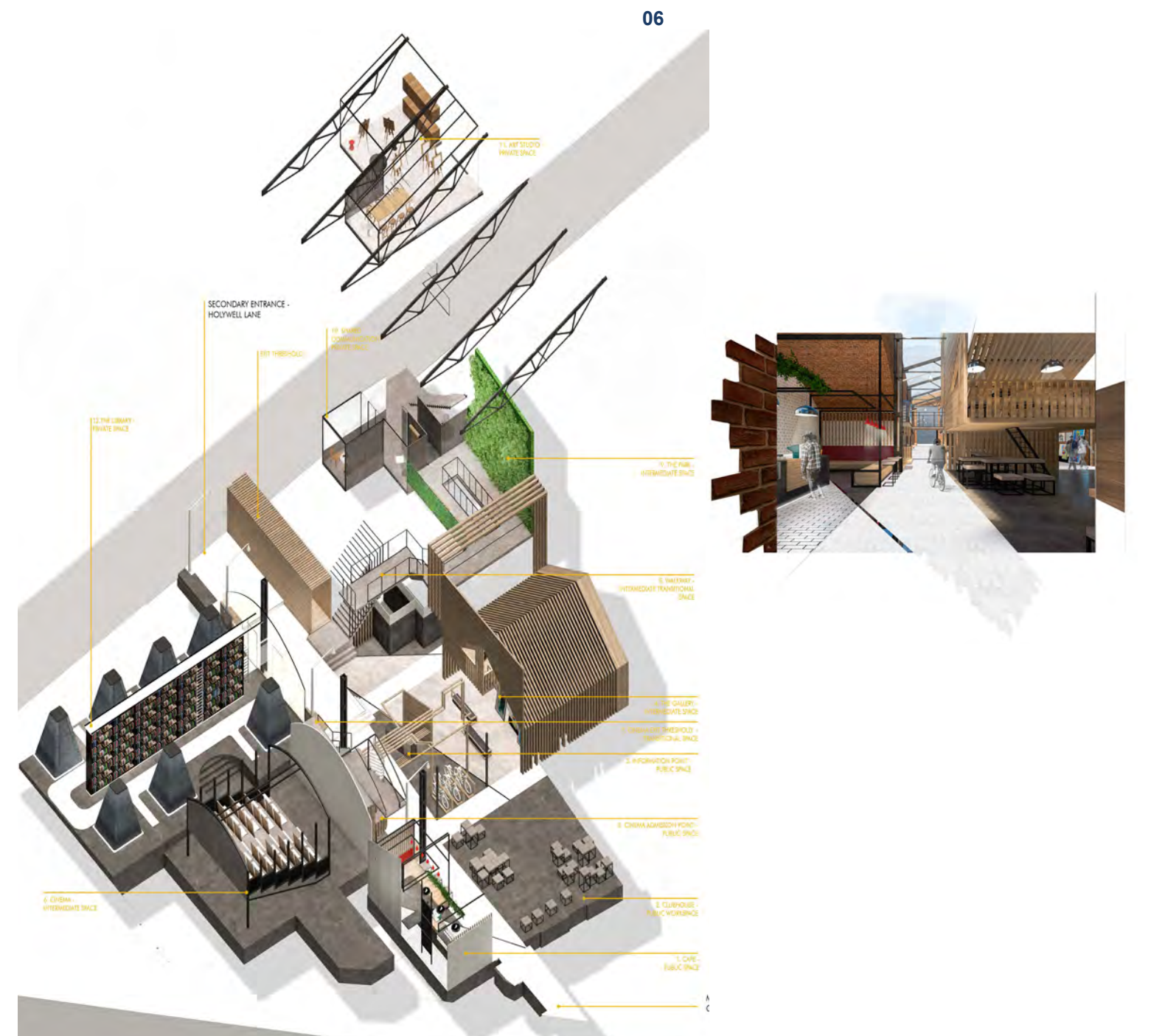
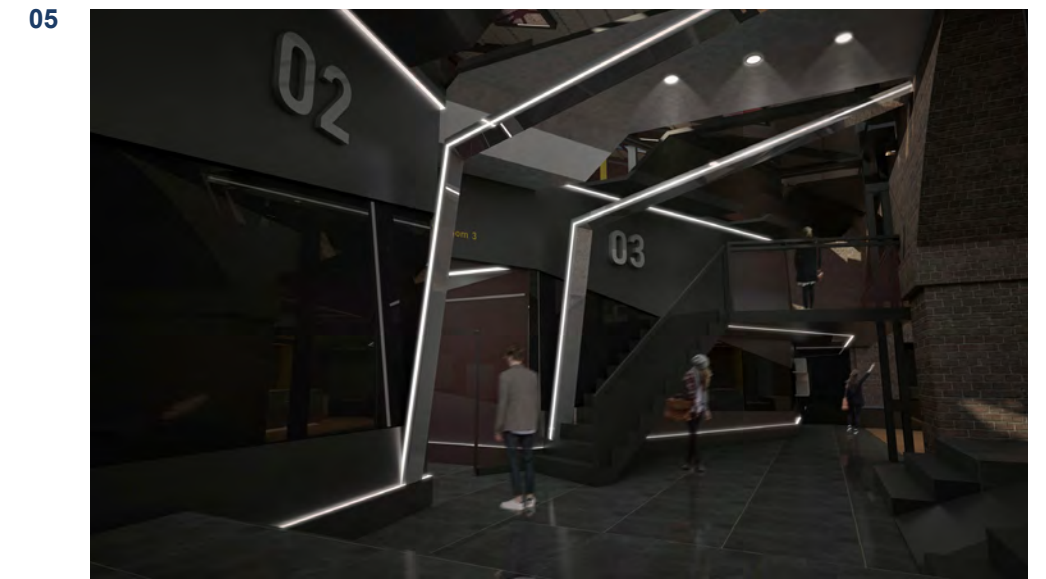

01

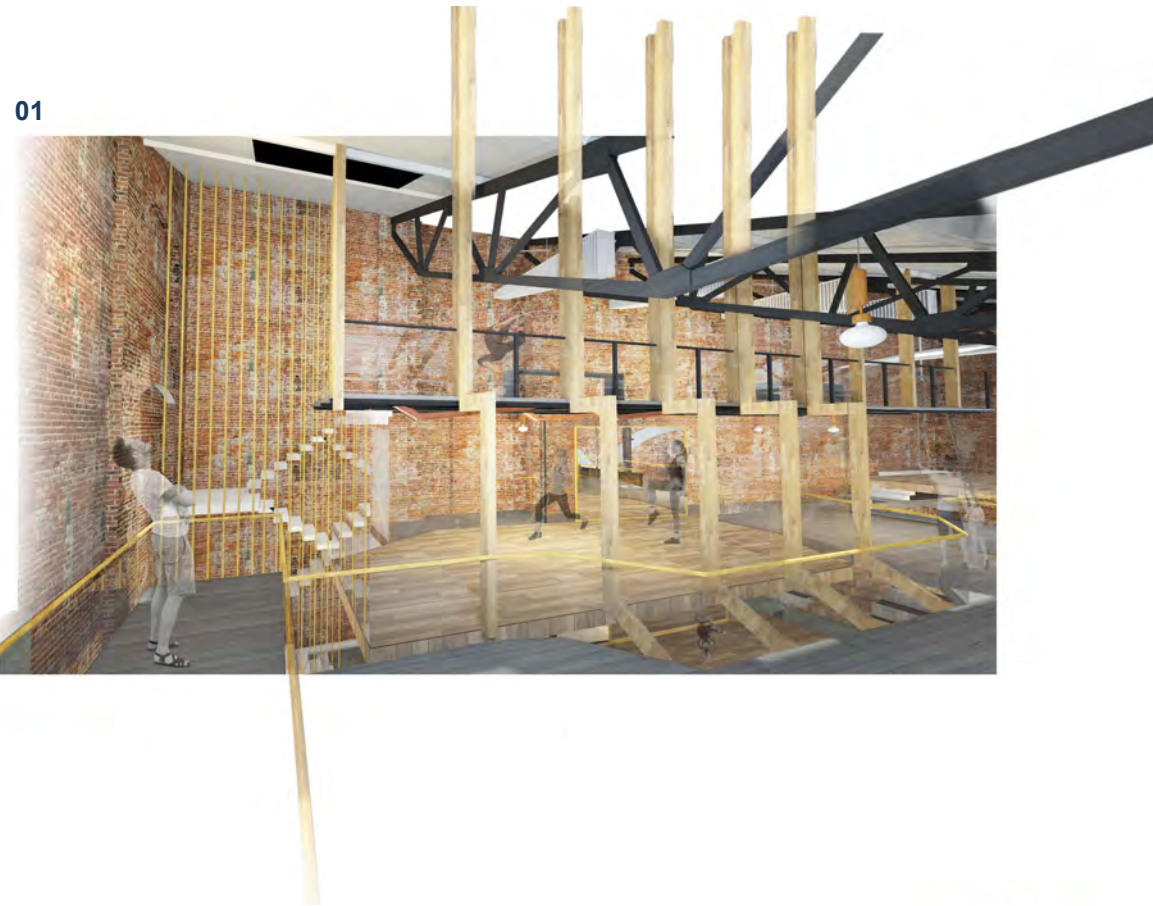

04



05



- 01 Valerie Akano
- 02 Gabija Viliute
- 03 Alicia Mae Waknell
- 04 Aleksandra Kmiecik
- 05 Victoria Kilypaite
- 06 Kotryna Skrickyte

02



03



06

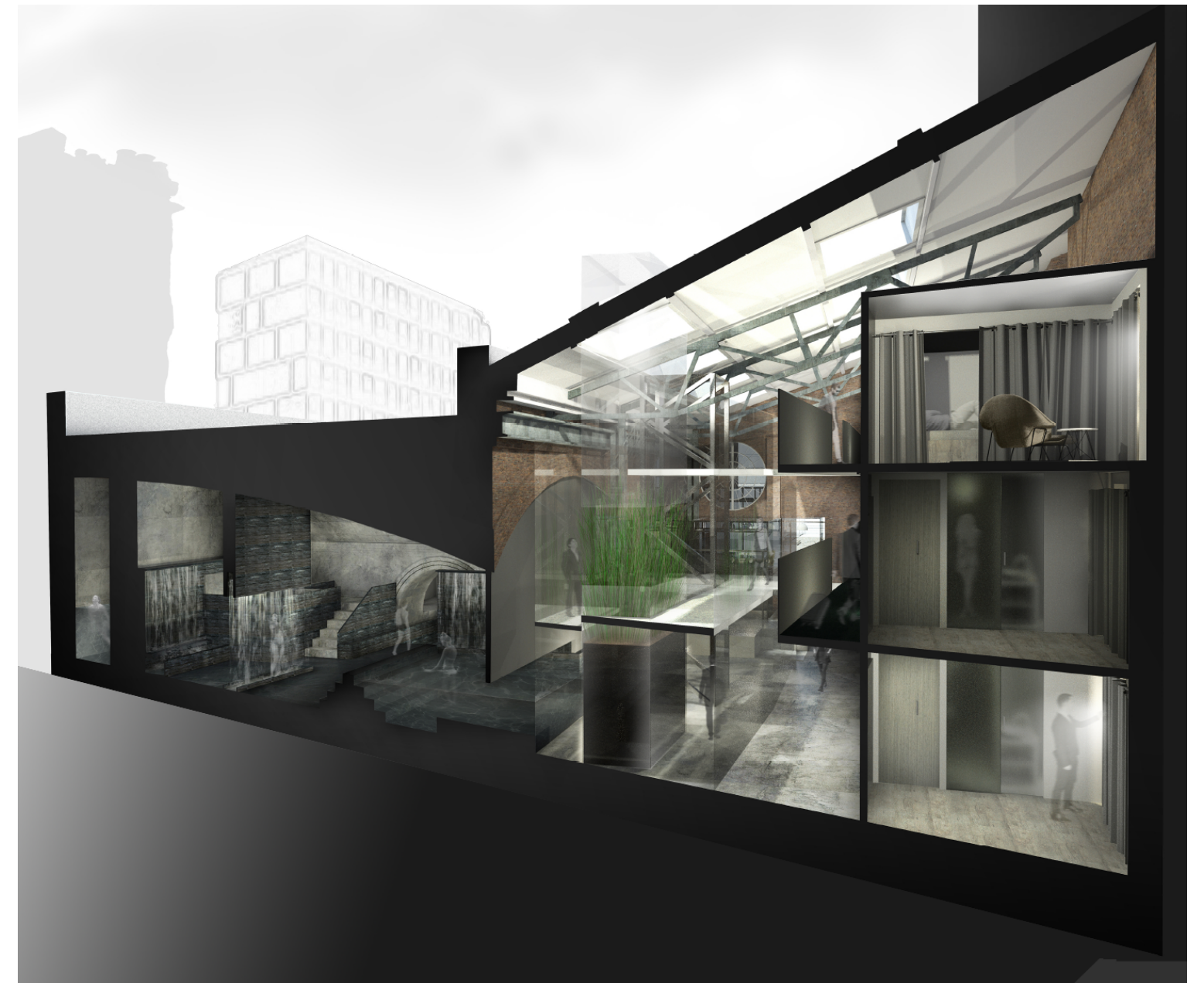

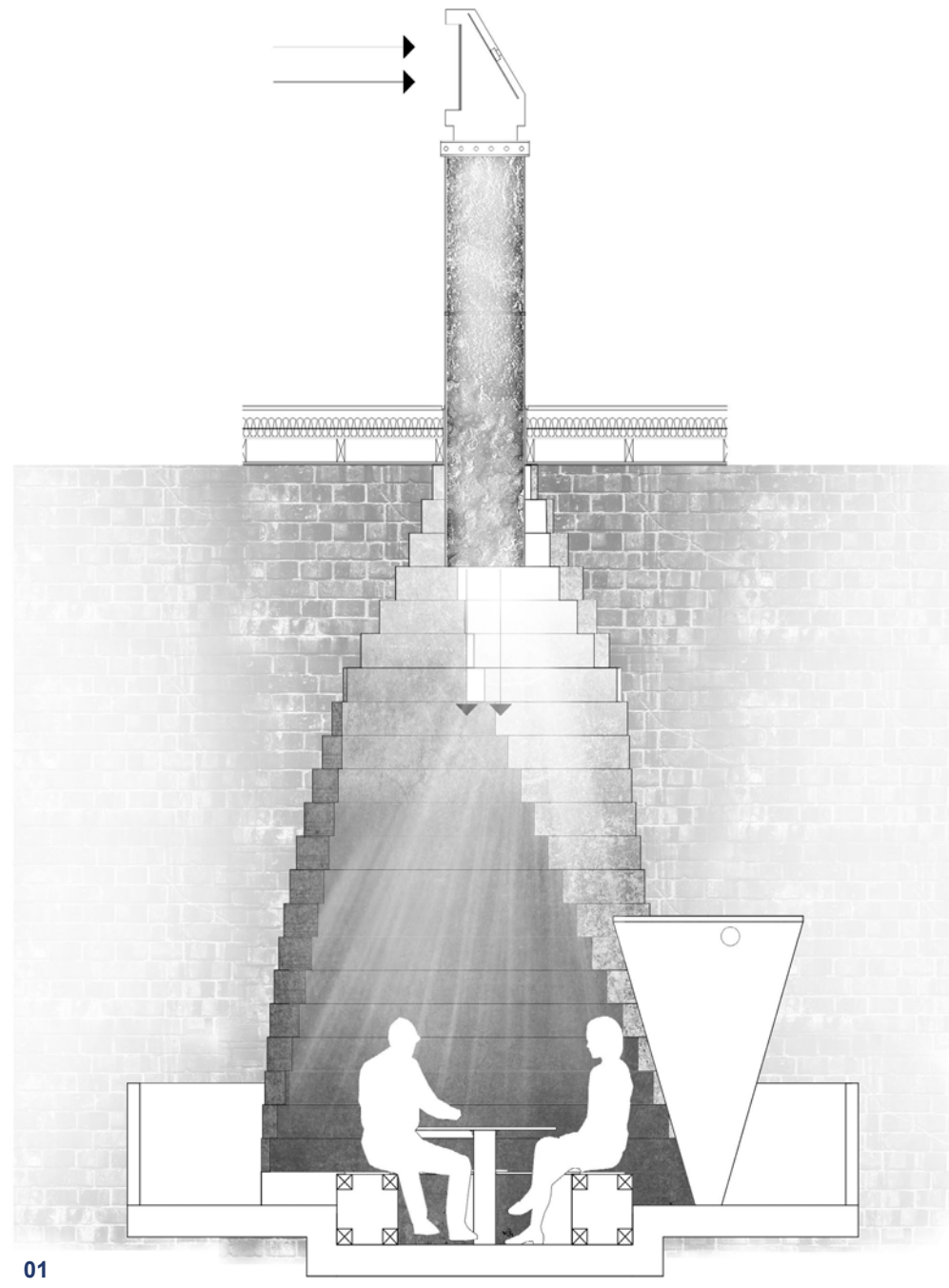

01



02



03

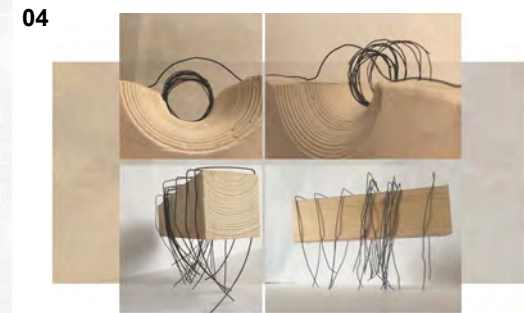

04

- 01 Anwar Omer
- 02 Angela Bonetti
- 03 Angela Bonetti
- 04 Angela Bonetti
- 05 Anitha kamalanathan
- 06 Ja Hkawn Kumje
- 07 Helen Dang
- 08 Anita Rai
- 09 Estefania Becerril Hernandez
- 10 Leah Brewster-Thizy
- 11 Kin Lok Lau



05

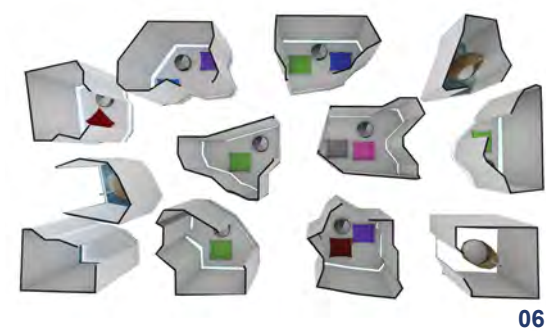

06

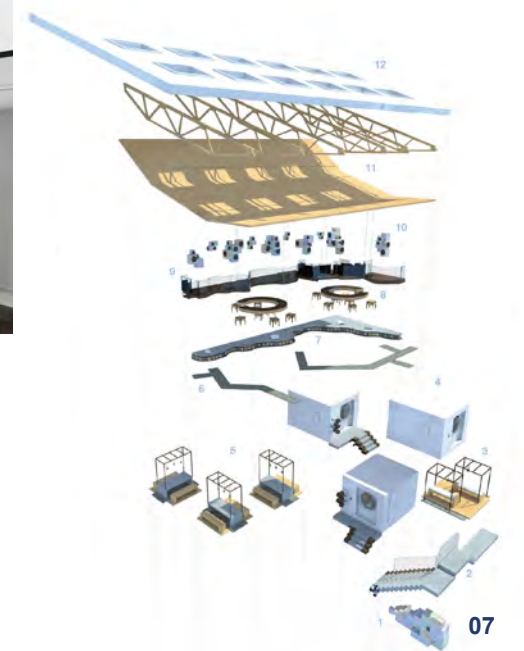

07

08



09

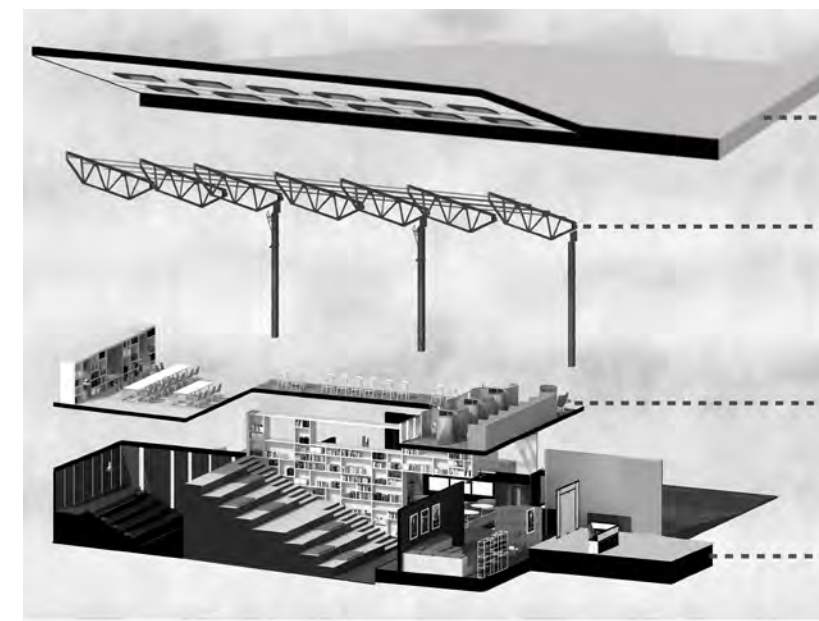

10



11

01



02



03



06

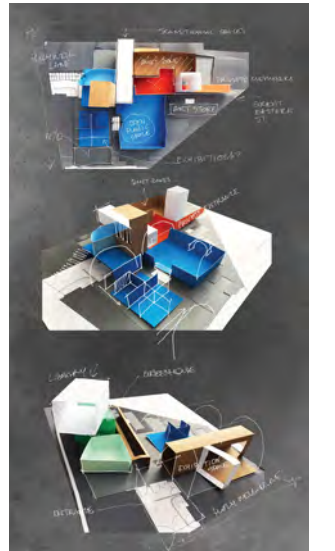

- 01 Erna Sejdovic
- 02 Mohanapriya Mahendran
- 03 Milana Milcanovska
- 04 Patricija Gadliauskaite
- 05 Vaad Asl Sharhani
- 06 Roxanne Stone
- 07 Juste Keliuotyte
- 08 Valentina Brughera
- 09 Priscilla Rizzieri
- 10 Silvia Jagdey



04

07

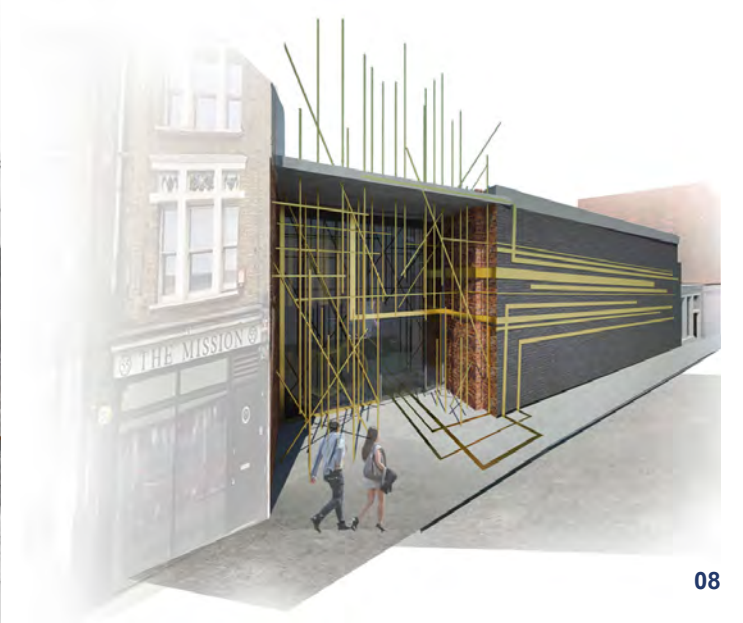
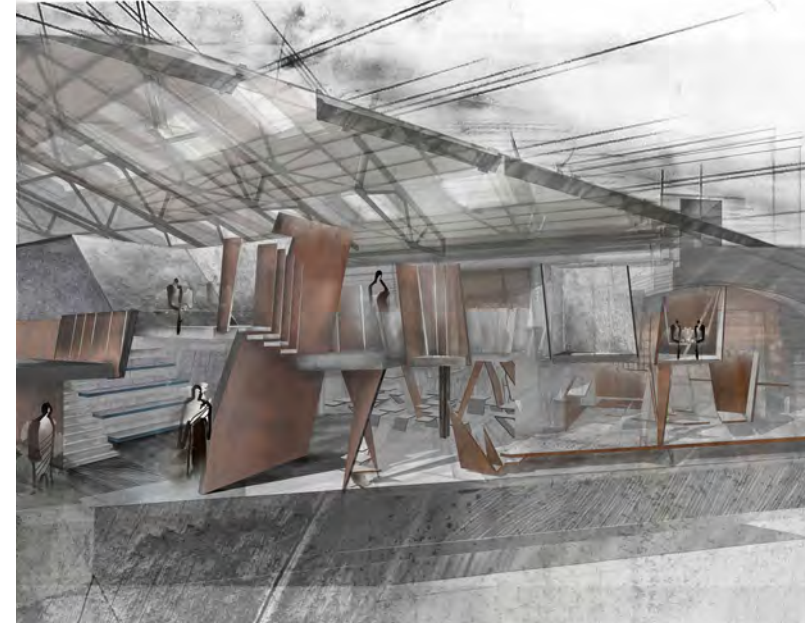

08

05



09



10

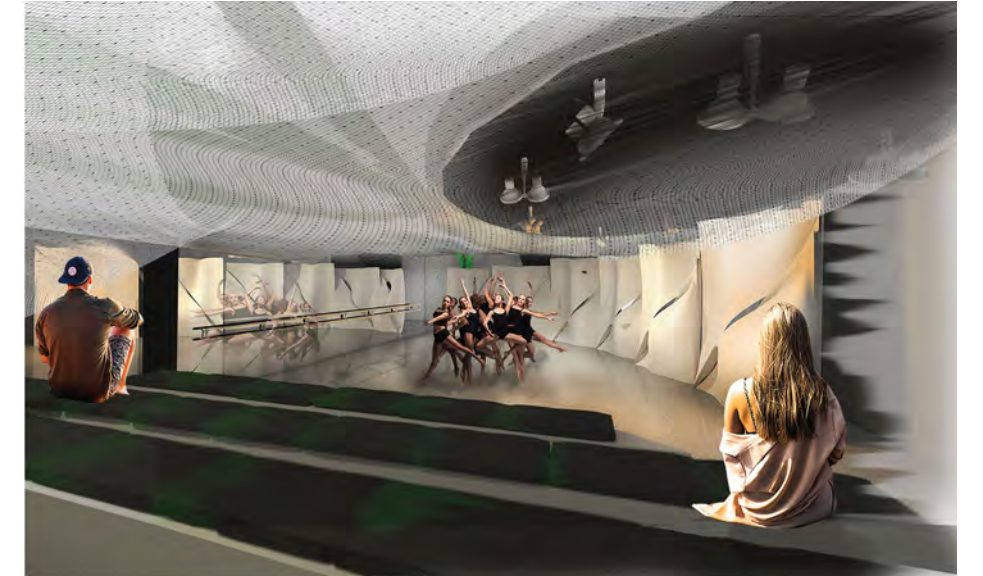

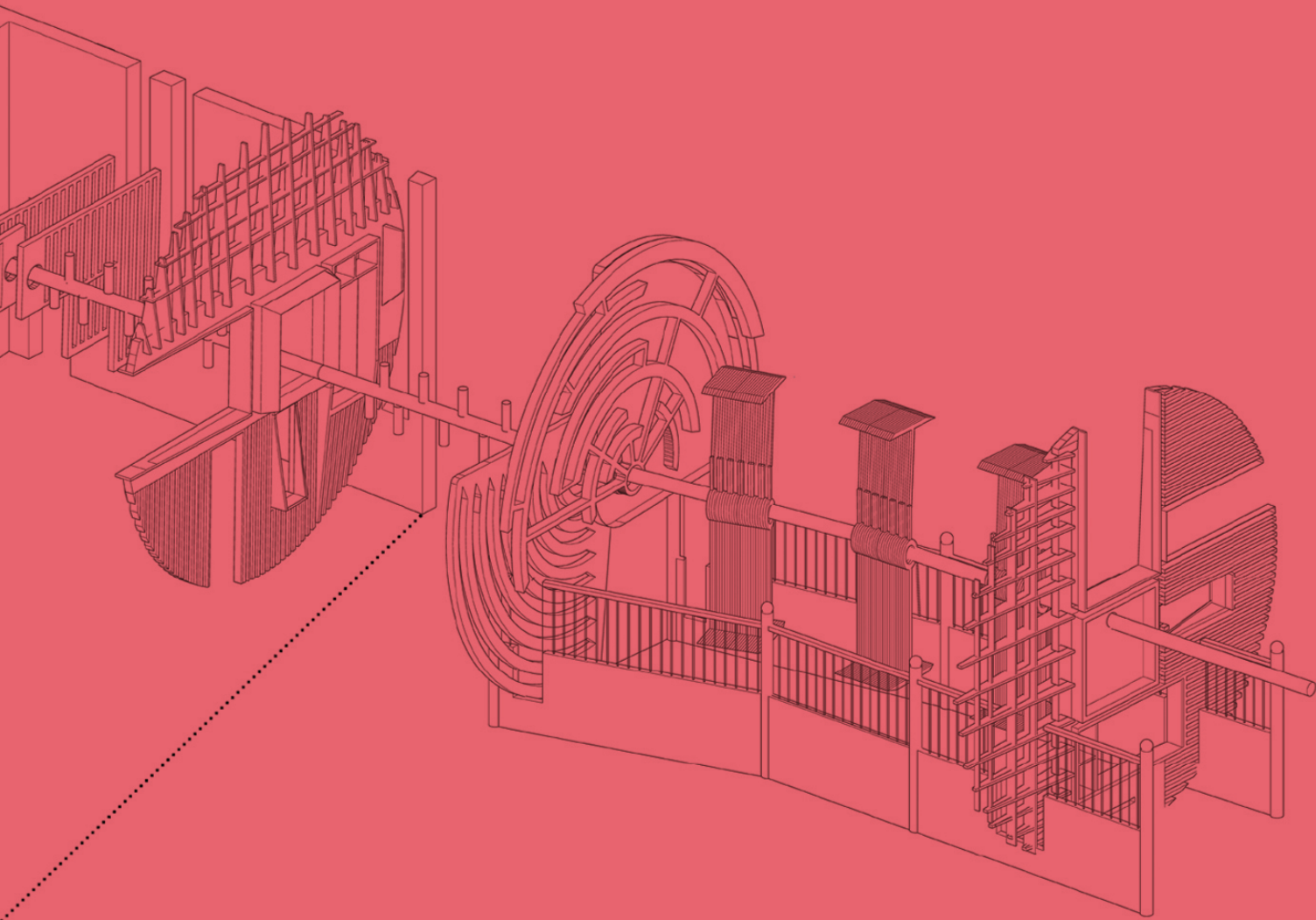

MA Interiors (architecture + design) provides the opportunity for graduates, current practitioners and career changers to further extend their academic knowledge of the interiors discipline by rigorously researching a particular area of personal interest. In combining knowledge acquired through taught theory, studio and workshop enquiry, and personal research students develop their own unique approach to the art of place making.

MA Interiors

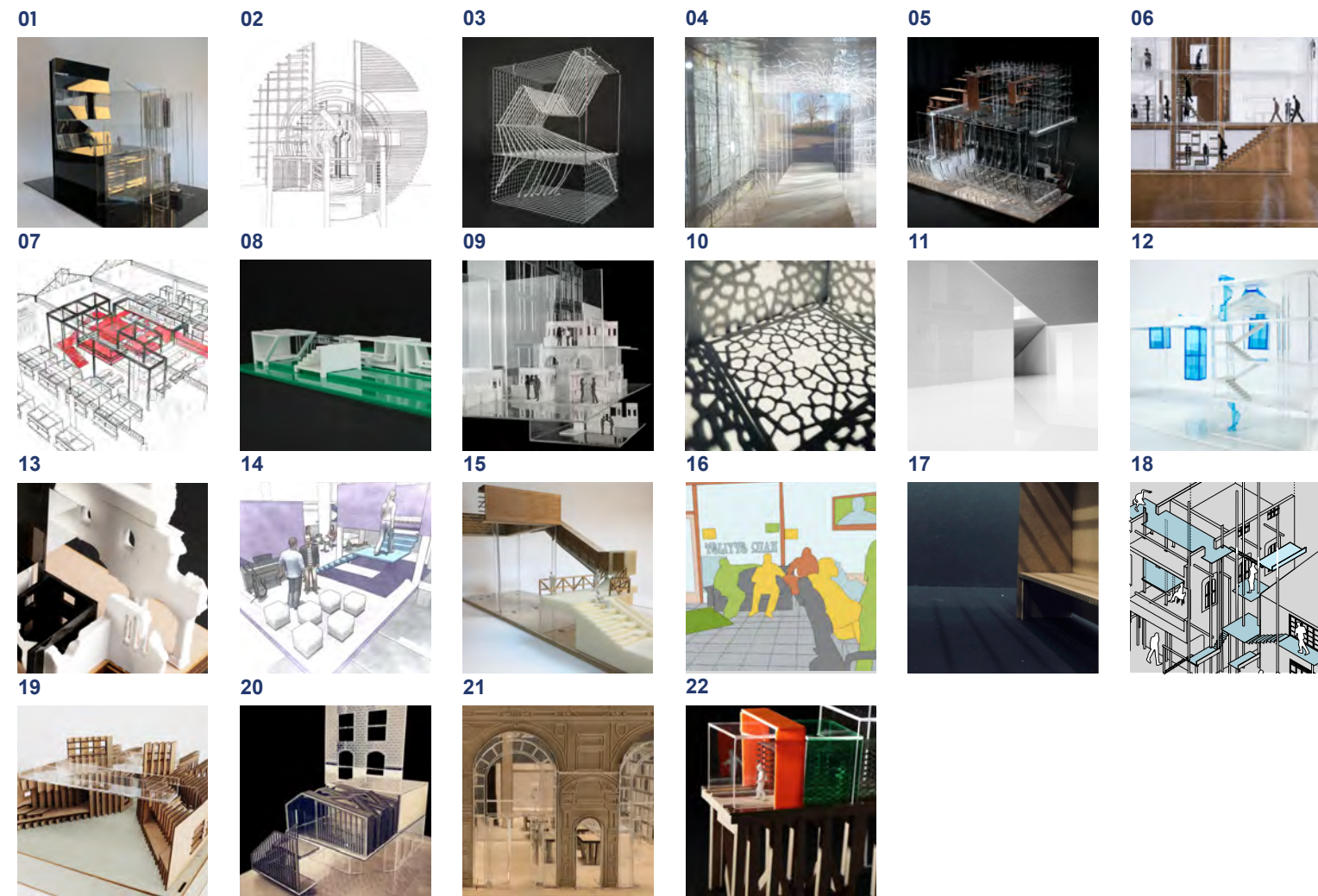

- | | |
|----------------------------|---|
| 01 Ana Popovici | 16 Nour Abdelhalim |
| 02 Anjali Rajmohan | 17 Filiz Bilaloglu |
| 03 Chen-Han Yu | 18 Mei Aoki |
| 04 Emma Ashton | 19 Ashikin Romlee |
| 05 Bouthavy Malavong | 20 Tanvi Ajay Agrawai |
| 06 Fox Wong | 21 Simran Narish Khatri |
| 07 Jack Phunyangxay | 22 Djamila Indira Coata Sanches Correia |
| 08 Menekse Celik | |
| 09 Mehrnoush Pouryan | |
| 10 Sahar Paknahadjabarooti | |
| 11 Luna Kim | |
| 12 Marselle Pena Jimenez | |
| 13 Mika Okazaki | |
| 14 Samar Ghaffoori | |
| 15 Sinclair English | |

In-Betweeness

Since 2015 MA Interiors has explored the notion of In-Betweeness and how it is revealed and interpreted within the city and its architecture. Students produce three publications that enable them to create a continually developing and accumulating record of their investigations and experiments, each volume informing the next, and together acting as a navigational guide for both student and reader.

Each publication acts as a physical record that communicates an exploratory narrative, where creative investigation informs speculation, design development encourages experimentation and critical evaluation results in the generation of innovative design strategies.

Book 1: Field Book asks students to become detective, design developer and maker, recording thisness and evaluating each expedition undertaken. Their reflections, of evidence found, are used to inform speculative yet innovative design interventions through drawing and making that disrupt and challenge social relationships, encourage new methods of encounters that create new common space and exemplify new forms of social relations.

Book 2: Design Development Manual promotes the importance of learning through production, developing and collating evidence to establish a design strategy and inspire an initial proposal.

Book 3: Detail challenges each student to deconstruct their developed proposals, reflect on the consequences of what they have designed and generate, in detail, a series of outputs appropriate to each individual proposal.

This year we have seen an array of heterogeneous project proposals and approaches, all unique in both ambition and application, that have challenged conventional understandings of the interior. Key areas of research have included isolation within

communities; homelessness; stress and anxiety; memory; obsolescence; addiction; hacking; squatting; re-use; alternative retail experiences; craft/tech and OCD, to name a few.

Alongside their studio work, students are required to participate in theoretical and critical thinking culminating in mandatory pieces of writing. This integrated approach to theory and practice is common to all MA Art and Design courses at Middlesex, and on the MA Interiors this year, to support the studio theme of In-Betweeness, the group responded to two critical project briefs.

Encounters (ART4001) centred on introducing the students to different critical approaches to space. These included notions of heterotopic space, place and non-place, public-private, transculturation, and work-home. All students had to evidence their understanding of the given theme/texts by writing a weekly blog and each was given the opportunity to present to the class, which led to invigorating class discussions that often went off on a tangent yoking design specific issues to wider discussions of technology, social media, gender and cultural memory.

Connect (ART4002) focused on students leading their own research having identified - through a process of constant rigour and elimination - their own specific research interests, which were particular to current trends in critical spatial research. A range of research topics developed from discussions of interior urbanism in living on water to establishing whether nature acts as an antidote to technology and how technology can complement nature. Each student was required to submit a fully annotated scholarly report demonstrating their research journey as well as the outcomes and discoveries.

01



02

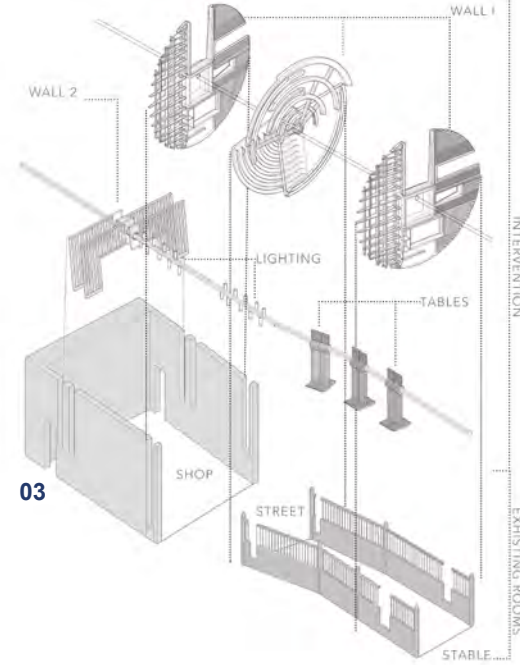

03

- 01 Ana Popovici
- 02 Ana Popovici
- 03 Ana Popovici
- 04 Anjali Rajmohan
- 05 Anjali Rajmohan
- 06 Chen-Han Yu
- 07 Chen-Han Yu

04

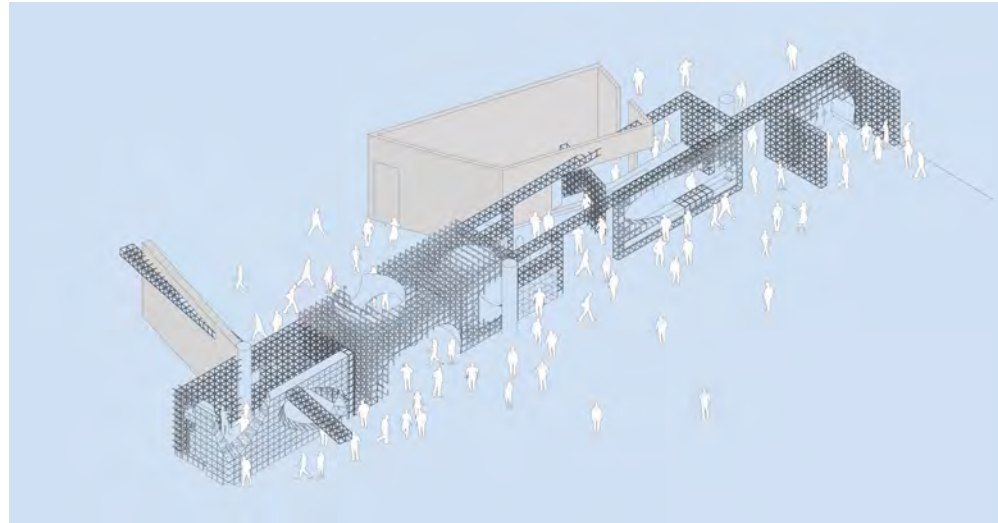

05

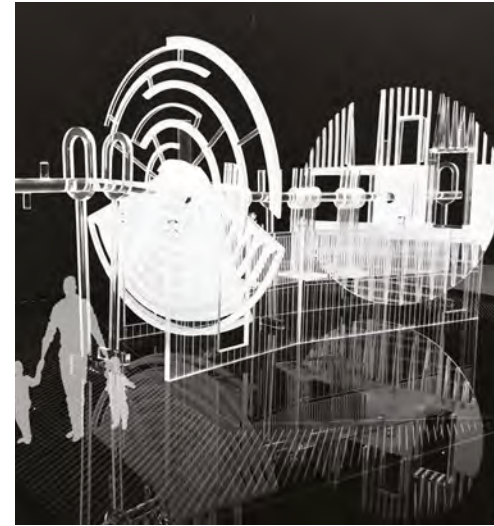

06



07

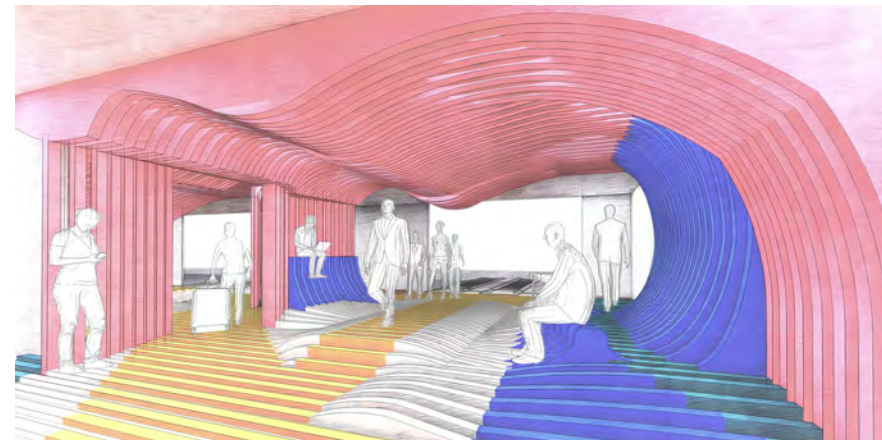

- 08 Bounthavy Malavong
- 09 Bounthavy Malavong
- 10 Bounthavy Malavong
- 11 Emma Ashton
- 12 Emma Ashton
- 13 Ashikin Romlee
- 14 Ashikin Romlee

08

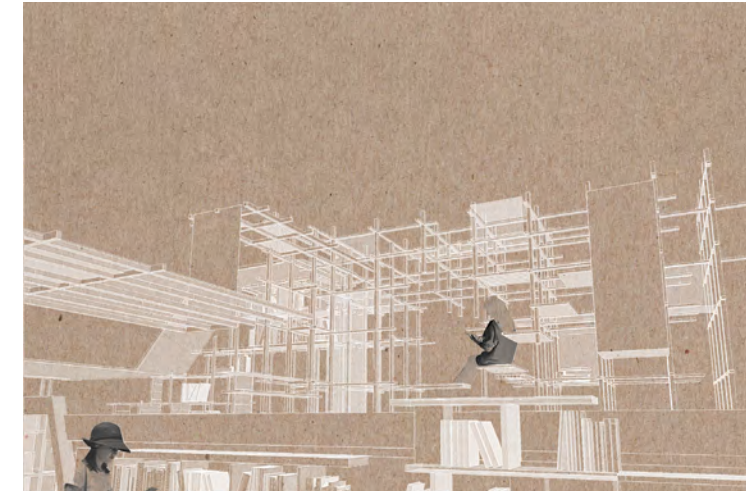
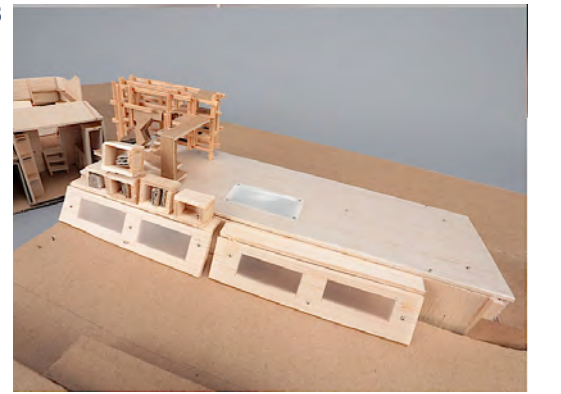

09



10



11

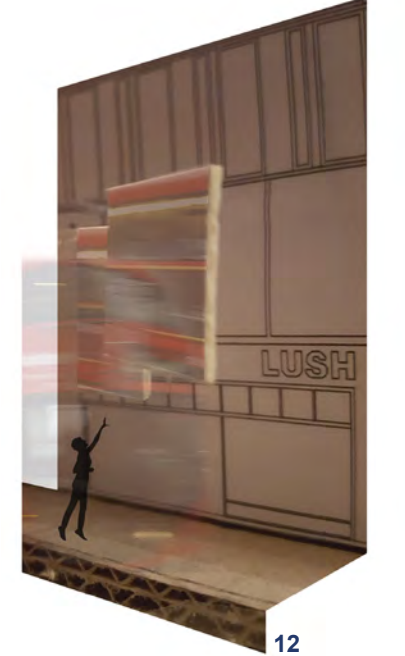

12

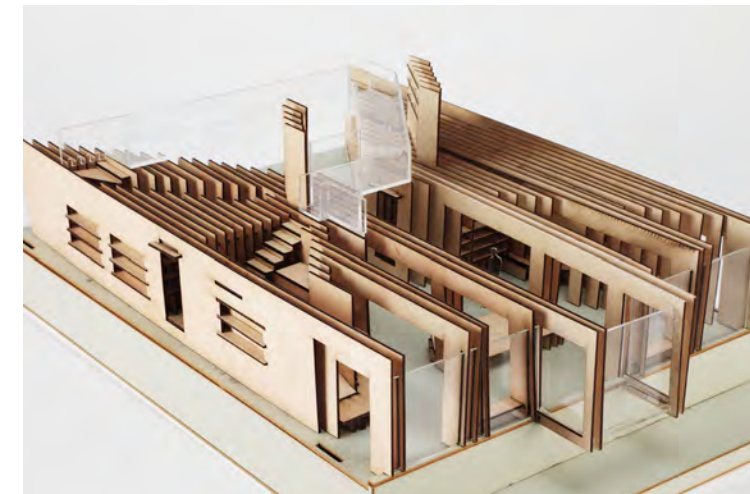

13

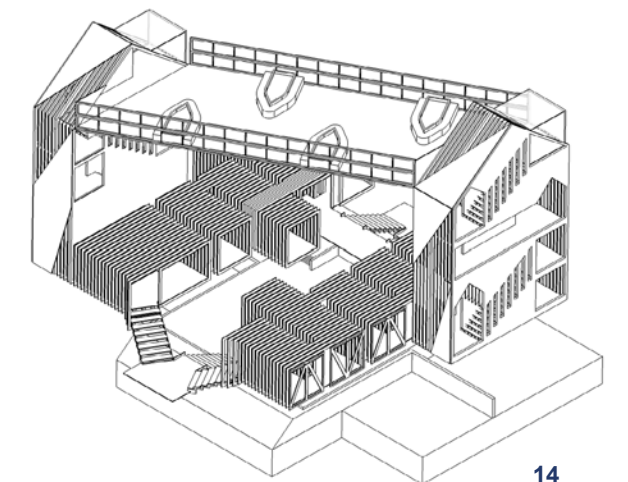

14

- 01 Fox Wong
- 02 Fox Wong
- 03 Fox Wong
- 04 Fox Wong
- 05 Jack Phunyvongxay
- 06 Jack Phunyvongxay

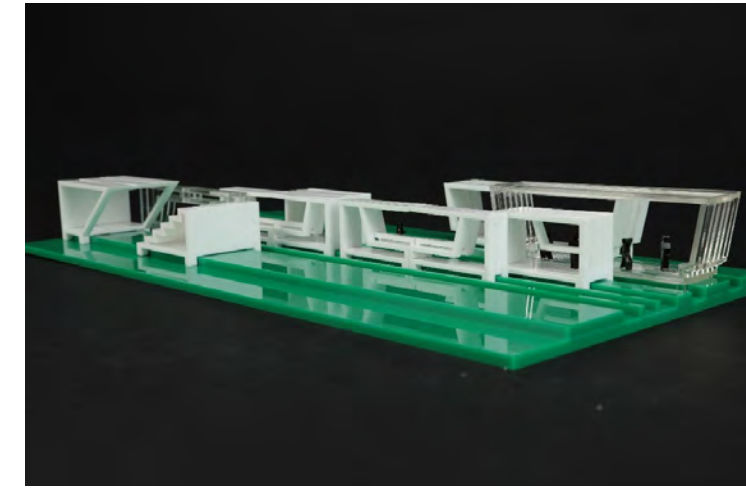
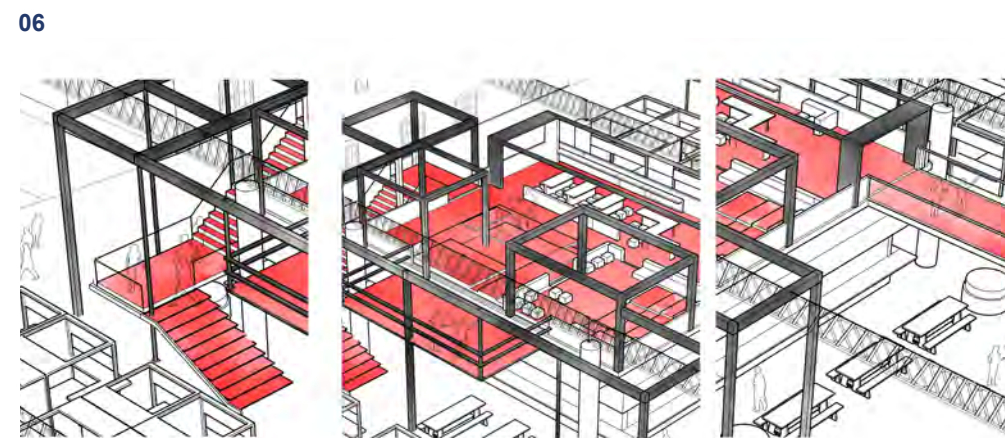
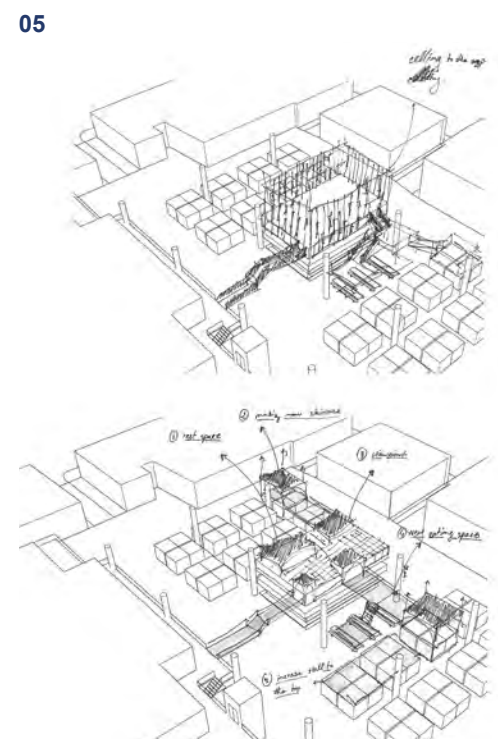
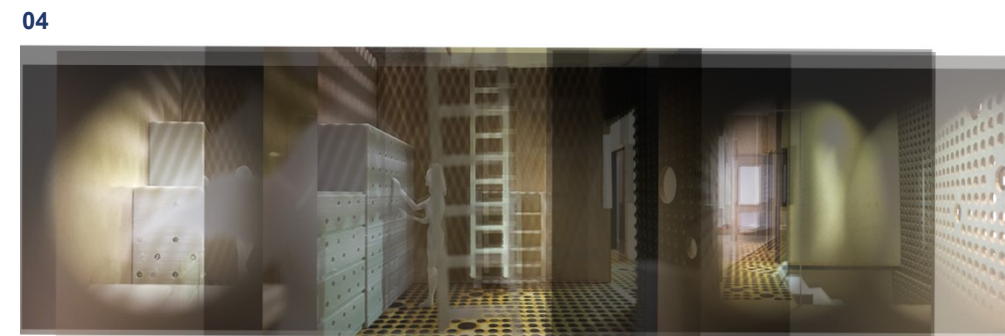

- 07 Menekse Celik
- 08 Menekse Celik
- 09 Sahar Paknahadjabarooti
- 10 Sahar Paknahadjabarooti
- 11 Mehrnoush Pouryan
- 12 Mehrnoush Pouryan

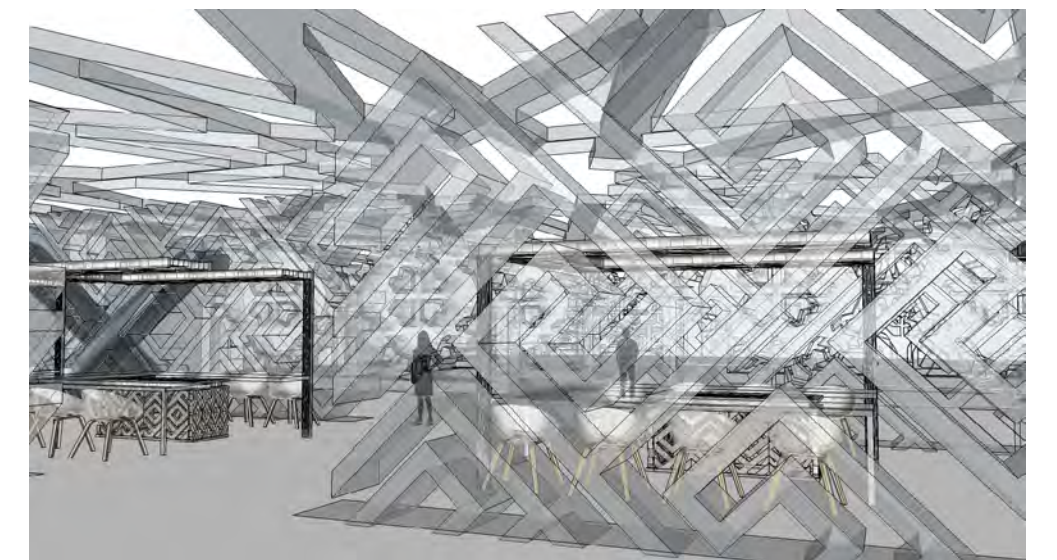

01



02

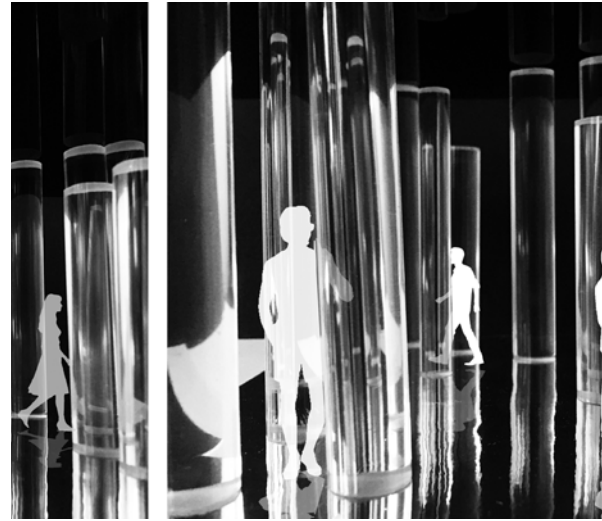

- 01 Luna Kim
- 02 Luna Kim
- 03 Luna Kim
- 04 Luna Kim
- 05 Mei Aoki
- 06 Mei Aoki

03

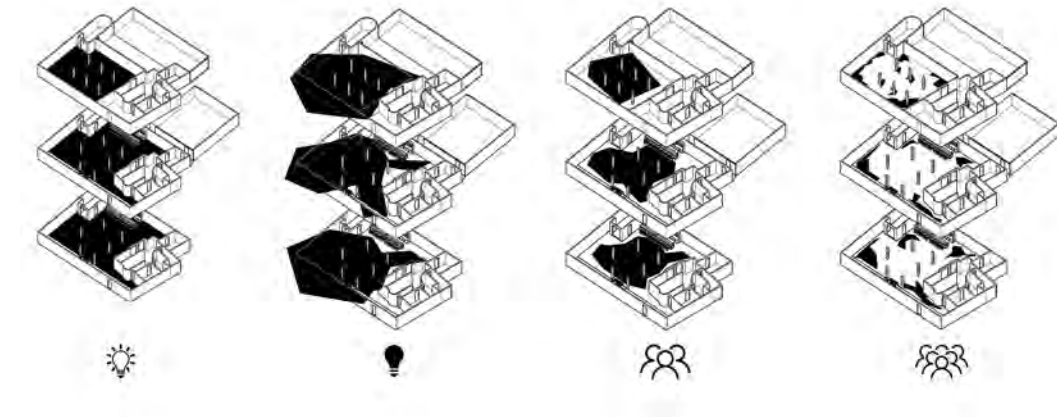

04

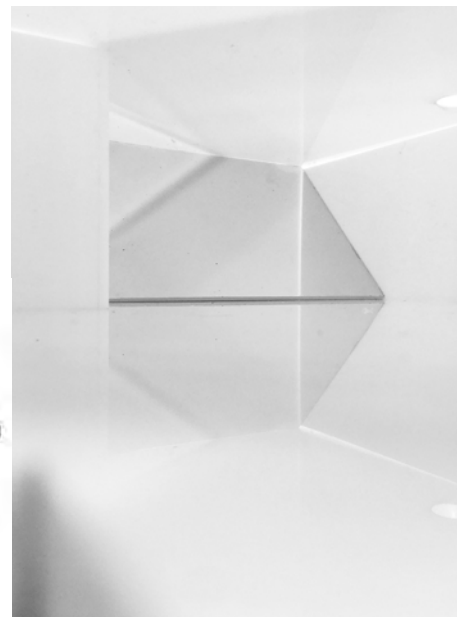

05

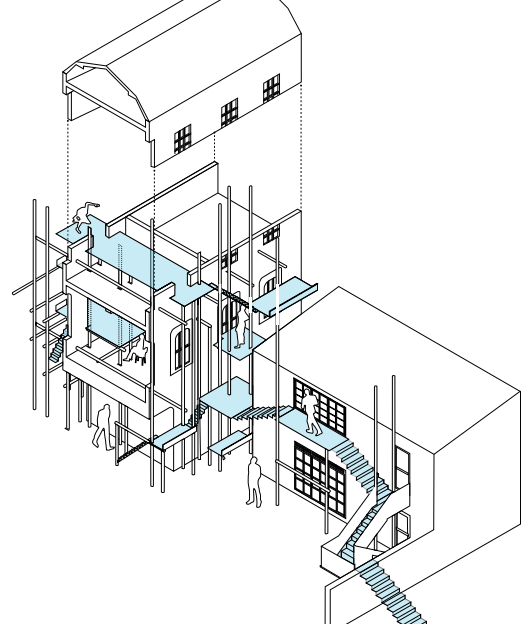

06



07

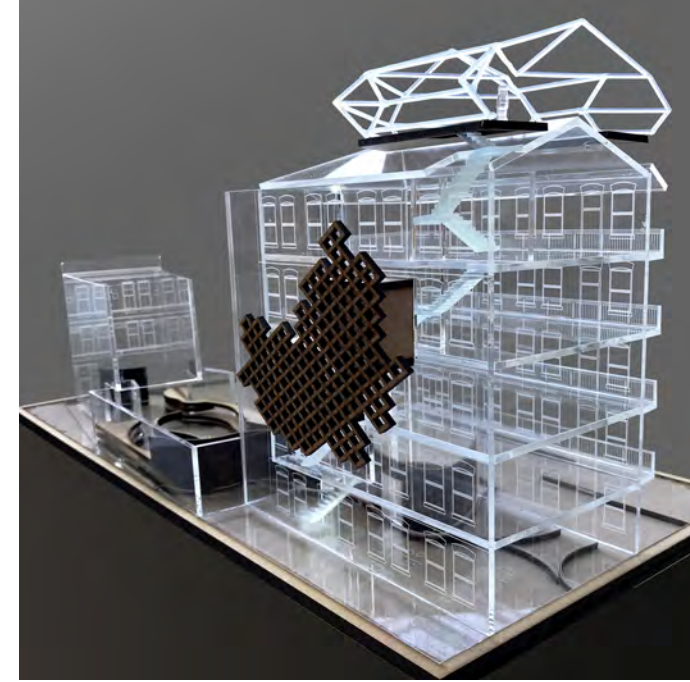

08



- 07 Marselle Peña Jimenez
- 08 Marselle Peña Jimenez
- 09 Marselle Peña Jimenez
- 10 Marselle Peña Jimenez
- 11 Filiz Bilaloglu

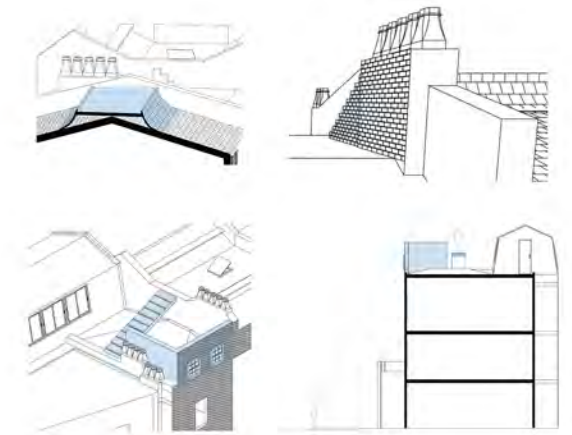

10

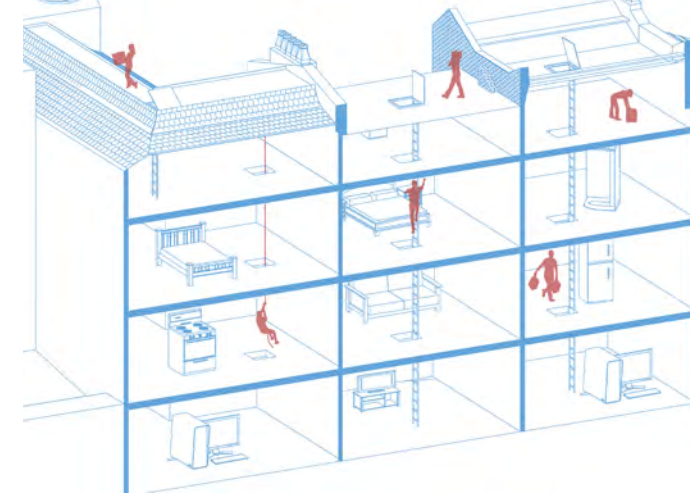

11

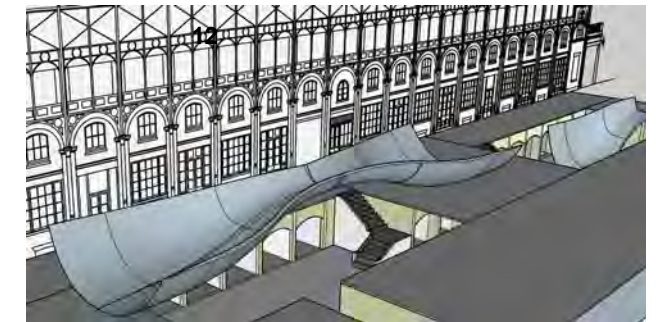



01

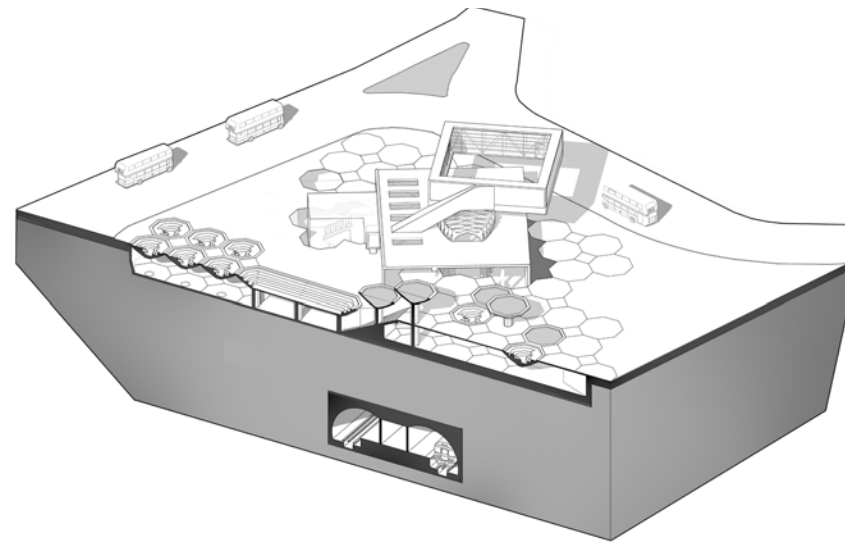

02

- 01 Sinclair English
- 02 Sinclair English
- 03 Sinclair English
- 04 Samar Ghaffoori
- 05 Samar Ghaffoori
- 06 Samar Ghaffoori
- 07 Nour Abdelhalim

03



05

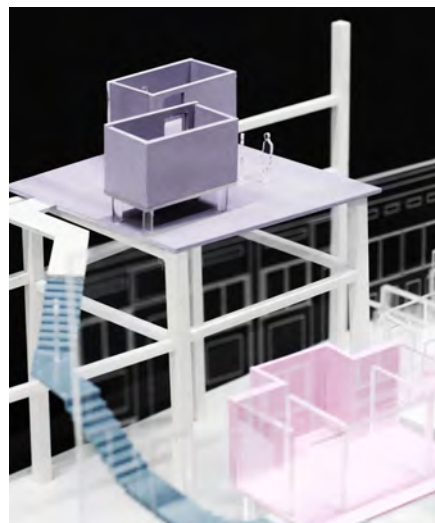

06

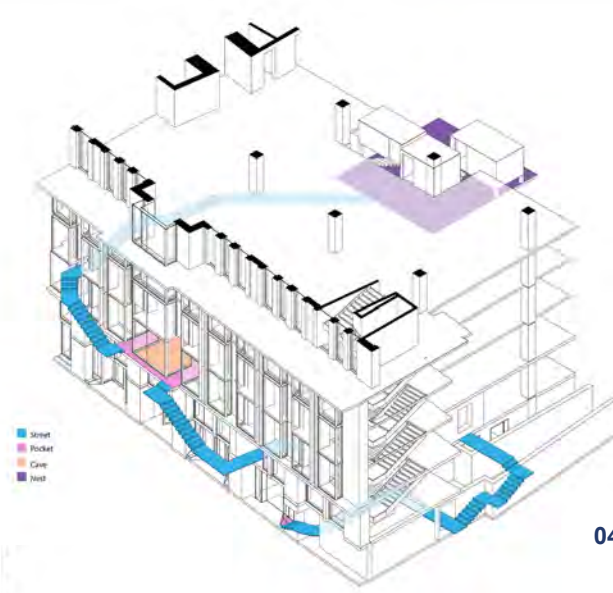
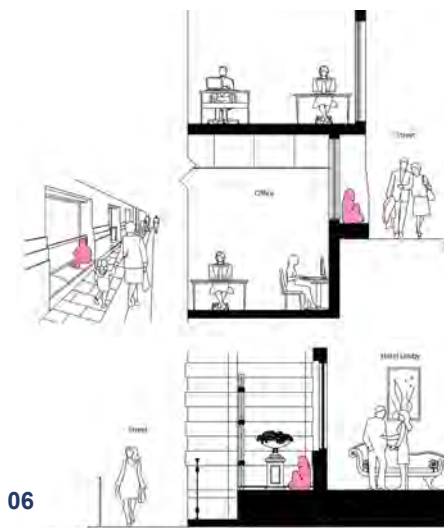

04

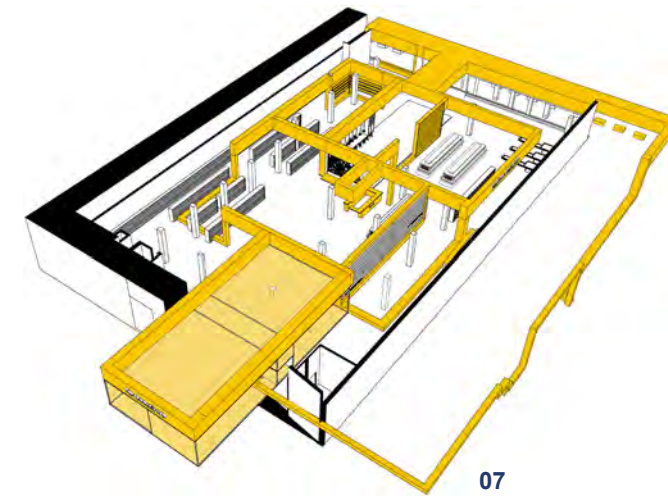

07



08

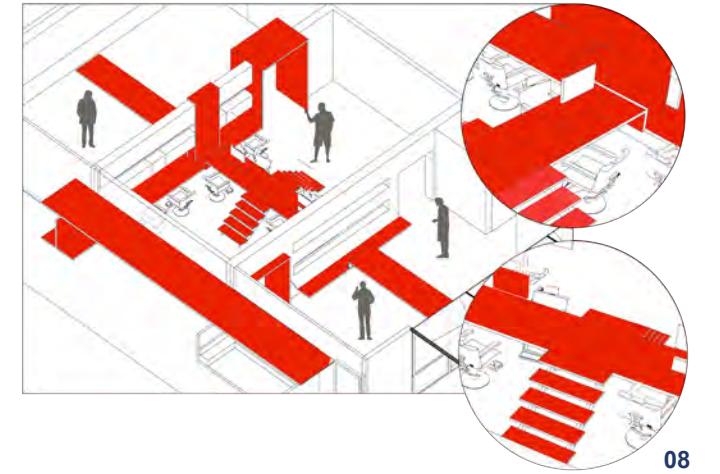

08

- 08 Nour Abdelhalim
- 09 Nour Abdelhalim
- 10 Mika Okazaki
- 11 Mika Okazaki
- 12 Mika Okazaki
- 13 Mika Okazaki



10

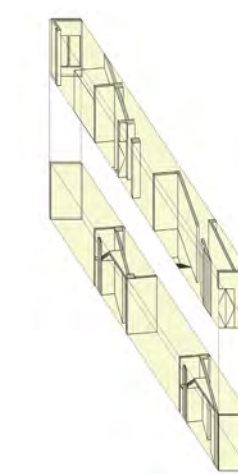

11



12



13

extraordinary scenarios

Students were asked to imagine extraordinary scenarios for historical interiors appointing them new functions. They were required to analyse how an alteration to the typical function of a place could affect the relationship between the materials and the components of the interior and also the surrounding environment and context. In particular, they had to focus on the relationship between space and people, imagining new types of behaviours that may happen in the imagined space.

a day at ...

Students were asked to spend one day in a famous public museum experiencing the space themselves. The task was about observing and meditating on the space through words and drawings; the research culminated in a Spatial Research Book where students, through visuals and text, explored some of the main features of the selected interior.

01

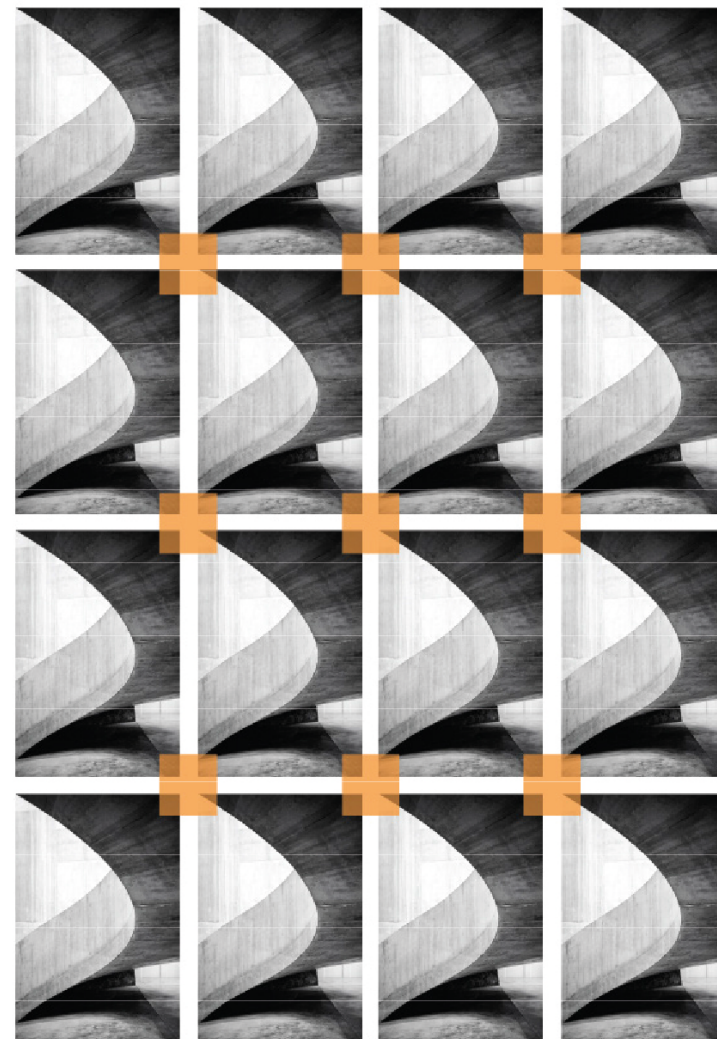

- 01 Rahma Yusuf
- 02 Claire Robey
- 03 Samin Souri
- 04 Marrieta Correia
- 05 Charles Hoar
- 06 Lucinda Hekneby

02



03



04



05



06

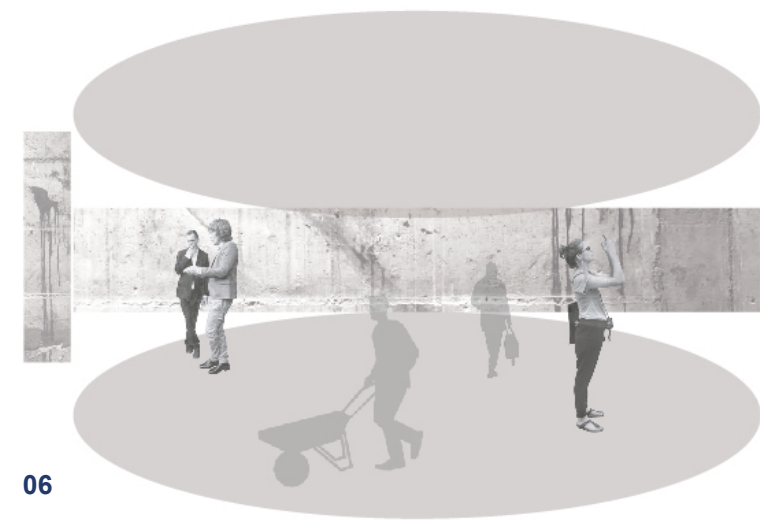

Very few designers work in isolation but work collaboratively with many people; their peers in a office/studio, their client and very importantly for the interior designer, with contractors who build their designs and bring design ideas into a reality.

Collaboration as a process is not always easy or straightforward. It involves; being open and enthusiastic about the possibility of your ideas being modified or reshaped, being interested in other people's ideas and visions, allowing yourself to think and act differently, embrace uncertainty and the unpredictable ideas that might be the product of this action.

Interaction

- Handle
- Lift
- Caress
- Manoeuvre

Surface

- Skin
- Sleeve
- Façade
- Edge

Volume

- Body
- Holder
- Tank
- Jacket

Extremity

- Legs
- Feet
- Skirt
- Periphery

Stance

- Balance
- Poise
- Equilibrium
- Behaviour

Action

- Dispense
- Deliver
- Ferry
- Locate

First year Interior Architecture and Interior Design students worked collaboratively on this project with first year students from the BA Dance programme. They were asked to design & build a free-standing structure, which provided a moment of enclosure and pause for a dancer. The structures were exhibited as part of an improvised performance. The students were asked to design each structure with the following requirements: The footprint of the structure needed to sit within a maximum area of 3sq metres and had to be built out of the following materials: Correx, corrugated cardboard, Tyvek and 25mm x 38mm softwood.

“Sometimes it takes that clash of personalities, styles or attitudes to come out with something new. Collaborative projects are great playgrounds to get out of your comfort zone and try new things. It’s exciting.”

—— Vsava, Bruno Selles



All students in the second year on both BA Interior courses were invited to join a competition set by Hammerson plc, a major owner, manager and developer of retail destinations across Europe. Organised in collaboration with Middlesex University, the competition asked students to question what the future of the Shopping Centre will look like and how owners might need to evolve to meet the new challenges presented by technological innovation and ever changing customer expectations. The brief was open to Middlesex University students across all subject areas, including those developing new digital technologies, and business students.

The interior brief we produced from this collaboration questioned the Future of Retail and how it must continue to adapt to changes in consumer activity and the social, cultural, economic and experiential demands of visitors and customers. Students were asked to address a new possibility for retail, one that does not yet fully exist and may become an idea that contributes towards an approach to future physical shopping. The priority was to create a new responsible form of retail - a shopping experience with a social conscience - by pairing an innovative retail idea with a charitable organization. The aim was for customers to benefit through gaining access to new products and services and acknowledging that a percentage of the profit made from retail sales will go to a benevolent cause.

Four students, two from Interior Design and two from Interior Architecture, were shortlisted to present their designs at Hammerson's headquarters and Interior Architect student, Claire Robey won Best Project for her innovative project dedicated to the sale of 3D printed spectacles utilizing hemp based filament.



01



02



03

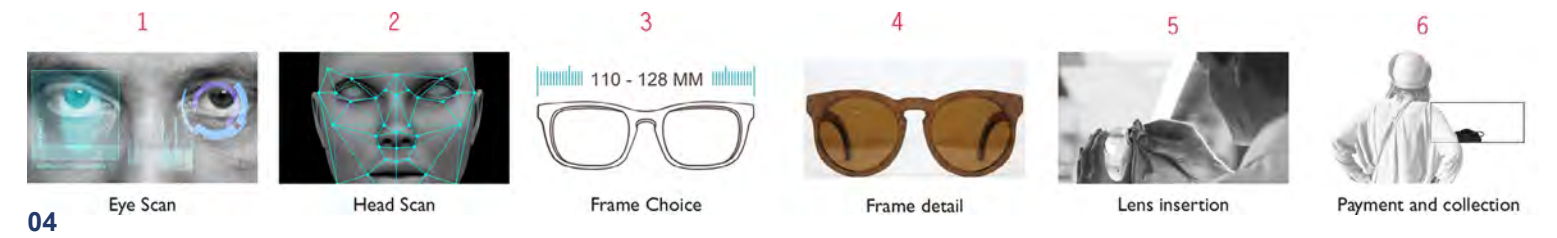

04



06

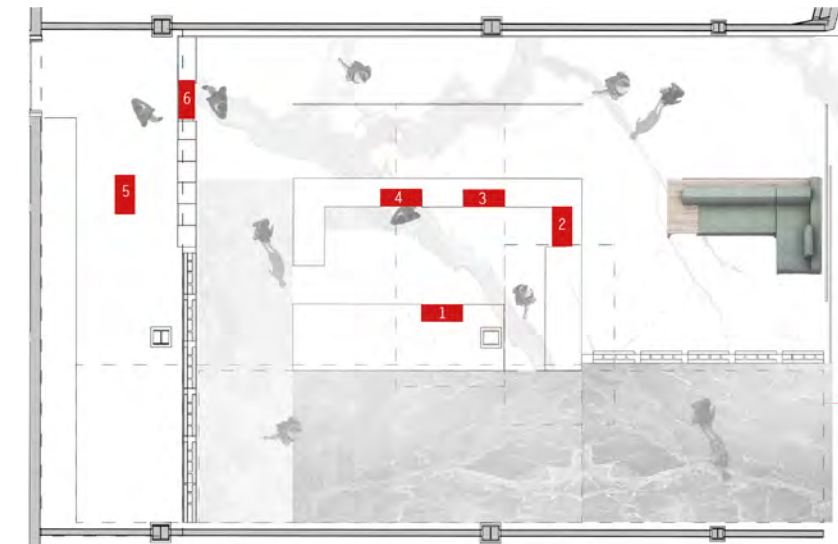

07

- 01 Lucinda Hekneby
- 02 Lucinda Hekneby
- 03 Lucinda Hekneby
- 04 Claire Robey
- 05 Claire Robey
- 06 Claire Robey
- 07 Claire Robey
- 08 Claire Robey

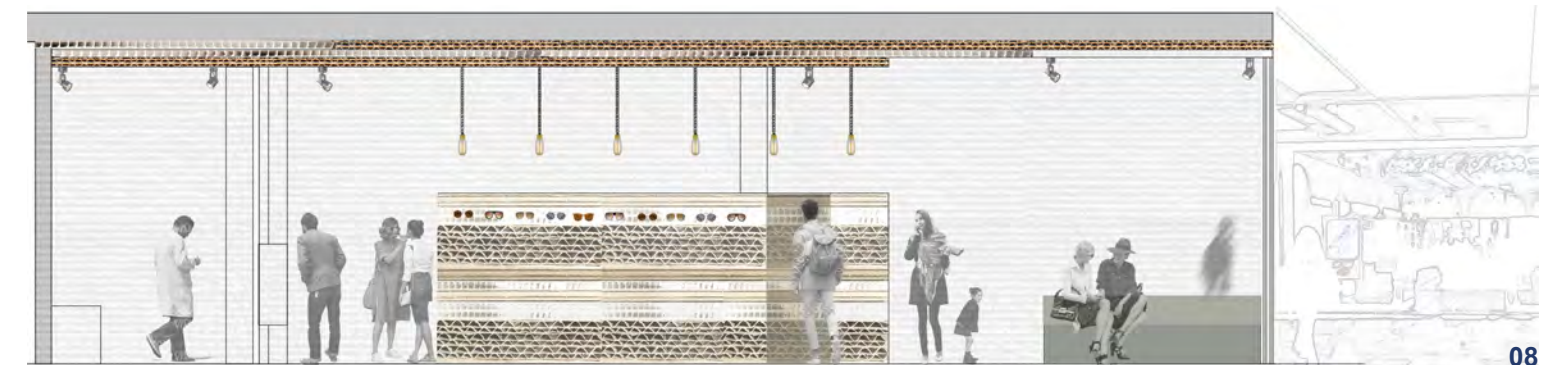

08



01

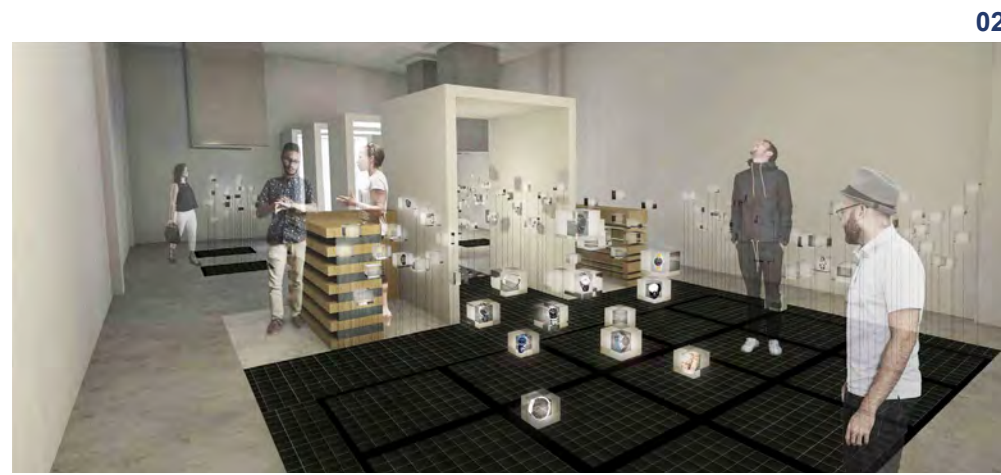

02



03

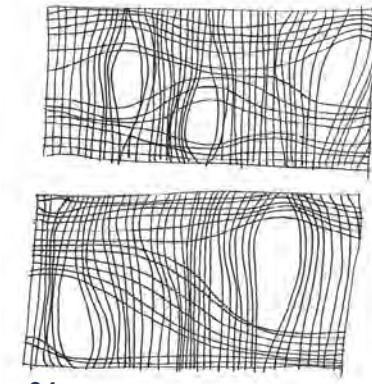

04

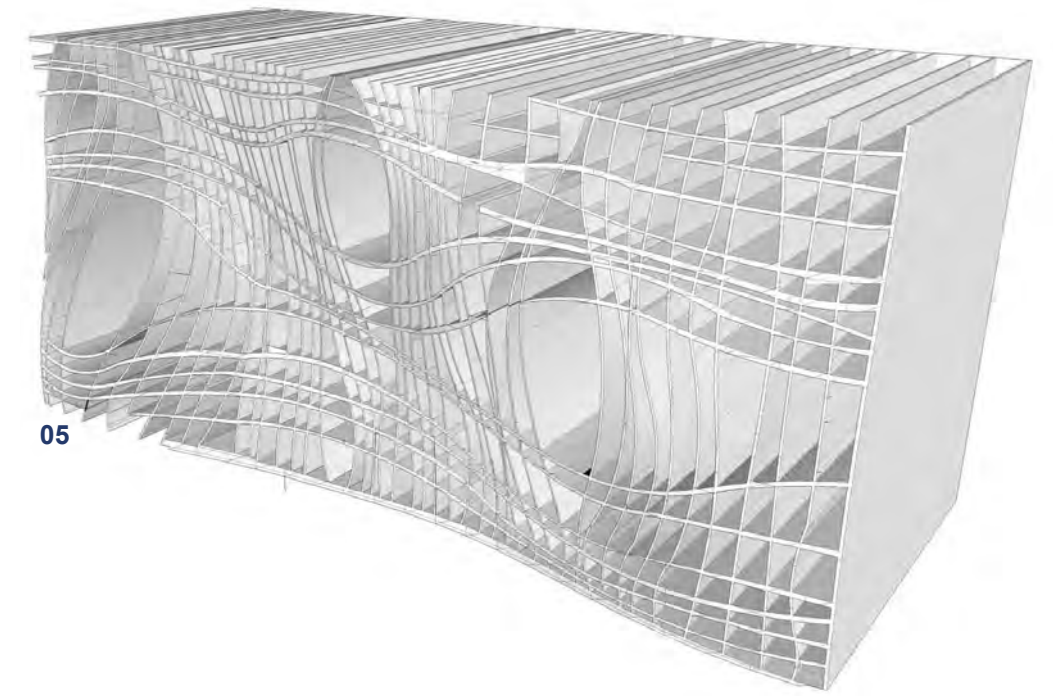

05

- 01 Geraldine Lopez Cuaican
- 02 Geraldine Lopez Cuaican
- 03 Geraldine Lopez Cuaican
- 04 Savanah Hyland
- 05 Savanah Hyland
- 06 Savanah Hyland

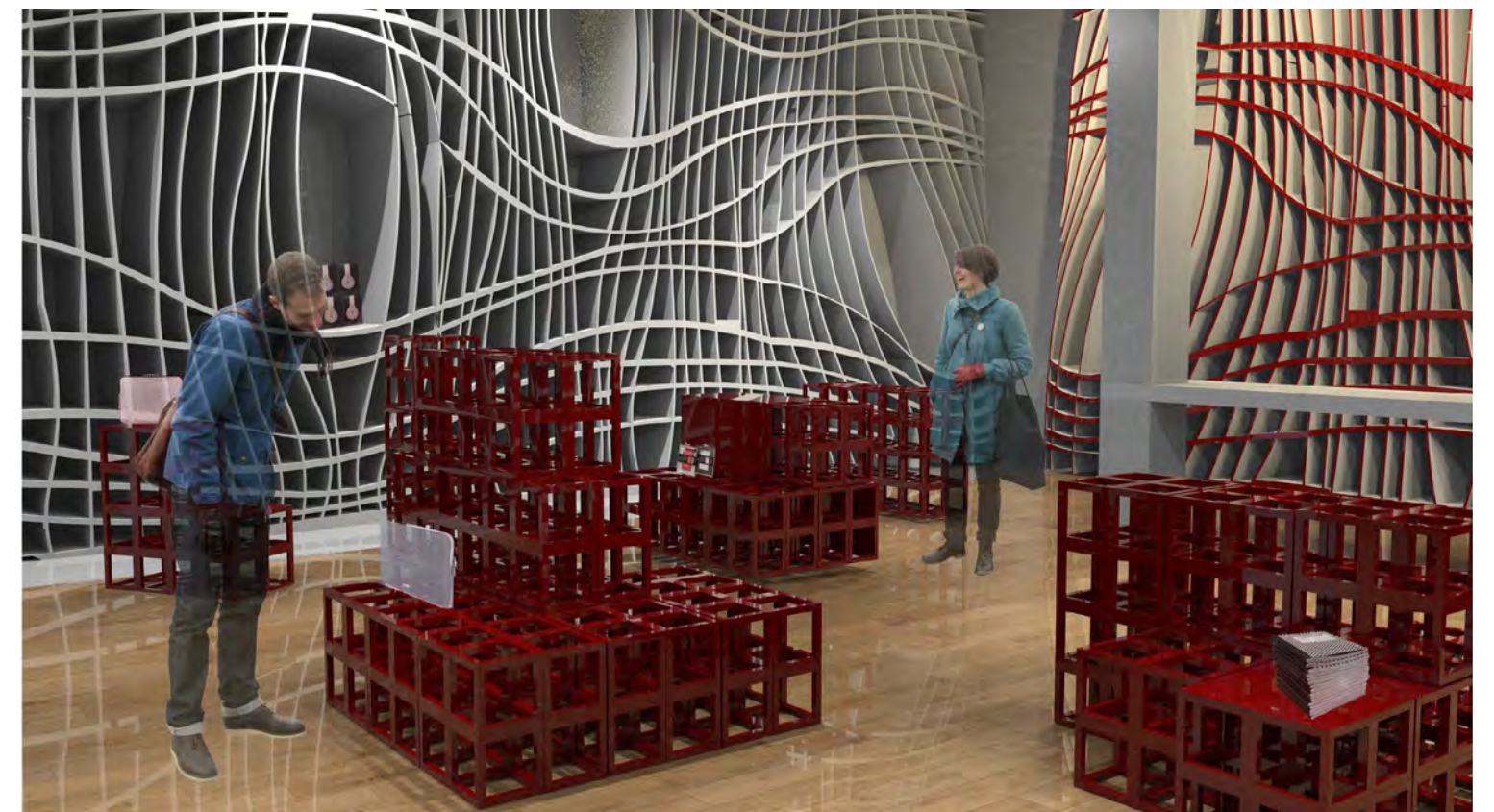

06

Both students and professional designers face a similar challenge when they present their speculative and unrealized schemes: how can they most effectively communicate the essence of a place that is not there? Traditionally this was through models and drawings, and more recently these traditional techniques have been enhanced and supplemented with digital design techniques such as photo-realistic renderings of spaces and places. Now, emerging technologies such as Virtual Reality (VR) give designers new tools with which they can represent and communicate their unbuilt ideas.

A problem with emerging technologies is that they can overly influence design outcomes, becoming less a tool and more an end in themselves. We saw this with the emergence of CAD programmes that led to a plethora of buildings and interiors exploiting compound curves or parametric design principles (most often without due justification). In these instances the new technology drives its own style. So we were wary of the risk that VR technology, which is most developed in the design of immersive computer games, would lead to a 'gamification' of our students' interior design proposals.

To mitigate against this we decided to only render final designs into virtual reality, once the major design decisions had been made. We thought that we could add a new layer of immersive experience to the models, drawings and renderings that students were already preparing for their final presentations.

Naturally, it was not so simple to translate files prepared in one software into files suitable for virtual reality, so we worked closely with colleagues in the university to find the best ways to bridge this. At the Degree Show in 2017 we showed an interim solution of digital student portfolios that could be navigated through a touch screen. Drawings could be enlarged and rotated, but the illusion of entering and navigating three-dimensional space remained partial. Nevertheless it showed the potential for creating totally immersive virtual reality spaces. In the second and final year of the funded project tutors Michael Westthorp and Jon Mortimer, together with specialist visiting lecturer Julius Augustinavicius, have developed techniques to bring students' designs fully into the realm of virtual reality. Working with staff from the Computer

'Digital Showscapes' has been a project funded by the HEFCE Catalyst Fund for Innovations in Teaching and Learning that gave Middlesex University BA Interior Design students access to VR software and hardware. Our ambition for the project was to enhance our graduating students' employability by giving them both a new and immersive platform to present their work to prospective employers, and also an introduction to presentation skills that would set them apart from other graduates in the job market place.

Science and Creative Technology programmes, we converted the students' computer model files from both SketchUp and Cinema 4D into the game development platform Unity. We chose Unity as it is free for the students to use and provides easy access to VR. Within this platform we are able to control lighting, colliders (physical barriers that the viewer will experience), the designed layout and the scope of the 'land' the viewers navigate.

For the Degree Show in 2018 we will be presenting a virtual landscape including fully immersive interiors for visitors to explore. We believe we are the first UK Interior Design programme to develop these techniques. We have considered how the work should be displayed within this immersive world, and where gravity can be suspended. How real do we want to make the experience? As a team we were keen to explore ways of displaying traditional presentation methods using VR, to augment the traditional degree show, so contained within this virtual world viewers will find pages direct from students portfolios, displayed as one would see them in an exhibition. Concept models, sketches and iterative scheme development can also be inspected as the viewer navigates the digital landscape.

Always conceived as a communication tool for the students' final projects, we are now aware of its shortcomings. The VR experience is still rather crude and simplistic: it cannot compete with the sophistication of photo-realistic rendering as a way to communicate atmosphere. But it does add a new sense of volume and three-dimensional space, so we are beginning to see its potential for the design process itself. It is a new way for students to explore their design concepts where the

detailing is subordinate to the overall sense of space, mass and volume. Looking ahead, we want to explore how VR can be used to promote students' assessment of their own work during design development. We want to consider how the new technology can enhance the students' design outcomes, if used carefully and with great thought, and to establish why the scheme is developing in a particular direction. As academics, we look to question the student who uses any technology simply as a means to an end. Virtual Reality is one other teaching tool that should supplement the existing techniques.

In the virtual landscape that the students are presenting this year, some of the most exciting presentations are axonometric drawings presented as three-dimensional floating sculptures. In a sense these might be said to 'gamify' interior design but they are entirely generated from the conventions of interior design practices. It is only their method of presentation that is new and which offers a new way of exploring space.



Left: 'Virtual Showcase' of student work. Below: Final year Interior Design students experiencing their design proposals in the virtual world.



re-imagine

The final year major project on our franchised Interior Architecture programme focuses on creating a lively community of co-working and co-living spaces for young entrepreneurs and startups in Central, Hong Kong.

According to Deskmag's Global Working Survey 2017, the number of co-working spaces has grown significantly from 5,800 to 11,300 since 2014 and was anticipated to further increase to 13,800 in 2017. The studio aims to investigate the effectiveness of shared working environments that have attracted many creative businesses and startups away from renting traditional office spaces. The module also explores how these shifts could be extended to re-imagine the possibilities of shared living spaces with housing affordability becoming an increasing concern for young creatives. With this alternative working and living model, students investigated the pros and cons of case studies to appropriately inform and inject creative ideas into this narrative.

The project is seen as an incubator for public support to foster creative digital technology based startups, rather than seeing young talents migrating to neighboring cities where workforces and spaces are considerably more economically competitive than Hong Kong. By re-imagining these spaces, the module highlights current social issues that impact on the economic potential of the city.

03



01 Group research
02 Jerry Chi Fai Yeung
03 Jesse Ming Kin Lee

01

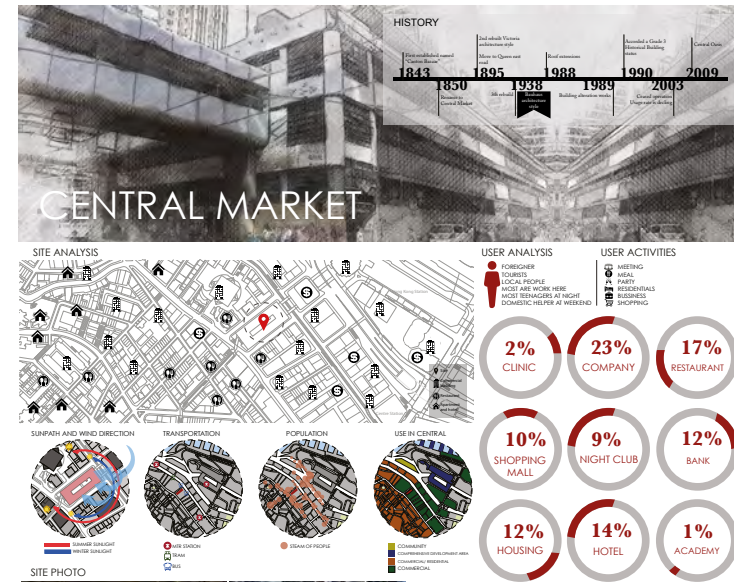

02

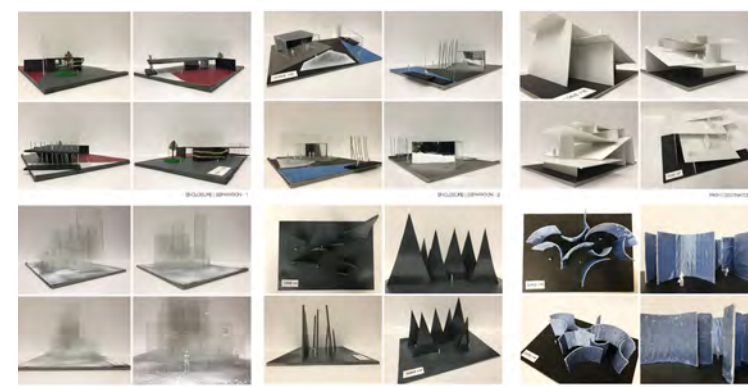

building a design community

In the ongoing discussion about pedagogies able to trigger a new mechanism in the conventional relationship between student and tutor, much attention has been given to peer learning. In a collaborative discipline, such as Interiors – where we are required to discuss, present and get feedback about our work from many different 'players', ranging from policy makers to craftsmen – conversations with a range of different tutors and colleagues is part of our studio culture.

If we expand this idea to the realm beyond the University, it translates to being aware of the role that the design community plays in our continuous education as designers. The first step in developing this Design Community is to create a strong connection between the University, students, former students and the professional world.

This year we have worked on different layers of collaboration, exploring ways of building mentorships.

Former students have produced an exceptional body of work over the years, relevant in terms of content, process and outcomes and situated in between university and practice. Agne Mankute, Heather Potter, Karolina Sileikaite, Lauren Slevin and Winson Yeung came back for a day each to talk through the work they did for their final major project and to exchange views on the current students work. It has not just been about showing and explaining their projects but also a reflection on methods, skills and how this establishes an approach to the practice of designing interiors.

In a similar vein, we asked second year students to read and make a critical review of some of the Writing Portfolios that have been produced in previous years.

Savannah Correia, Amanda Hvile, Karolina Klonowska, Leora Morris, Heather Potter, Karolina Sileikaite, Lauren Slevin and Winson Yeung were interviewed – in London and remotely across the globe - to add to their writing a broader context, process tips and editing choices.

Adding to our design community are the many contributors to the Visiting Lecture Series that we run every year. These lectures are valuable catalysts to inform students about life in professional practice. We have hosted talks this year from Adam Brinkworth, HMKM Creative Director, Paul Digby and Simon Krapf, Senior Designer at Kinnersley Kent Design. In addition, we have also welcomed professors to speak about their teaching and practice from our valued partners, ICS College of Arts in Tokyo and Politecnico di Milano.

Monday 12 March
Portfolio Presentation Series: **Lauren Slevin**

Winner of 2017 IE Award
Ex-student, Lauren Slevin (BA Interior Architecture) will present her portfolio and join us for a session of reviews.
All years are welcome.

10AM - Room R212

Thursday 01 March
Portfolio Presentation Series: **Agne Mankute**

Ex-student, Agne Mankute (BA Interior Architecture) will present her portfolio and join us for a session of reviews.
All years are welcome.

2PM - Room R212

Monday 26 February
Portfolio Presentation Series: **Winson Yeung**

Ex-student, Winson Yeung (BA Interior Architecture) will present his portfolio to current students and join us for a session of reviews.
All years are welcome.

10AM - Room R212

Thursday 19 April
Portfolio Presentation Series: **Karolina Sileikaite**

Ex-student, Karolina Sileikaite (BA Interior Architecture) will present her portfolio and join us for a session of reviews.
All years are welcome.

10AM - Room R212

INTERIORS: PRACTICE TALK

WEDNESDAY 11 APRIL 5PM R201

INTERIORS: PRACTICE TALK

ADAM BRINKWORTH
talks about retail design

Wednesday 08 November 4.30PM / R101

INTERIORS: GUEST TALK / 2017

Japanese Interiors

By visiting lecturers from ICS College of Arts, Osaka

Thursday 09 November 5.00PM / R201
Friday 10 November 10.00AM / R201

Interiors Lecture: Giovanna Piccino

Professor of Interior Design, Politecnico di Milano

Wednesday 29th April 0201/0203 4.30 PM

Open to all students



Editors
David Fern
Francesca Murialdo

Editorial Assistance
Naomi House
Ashna Varma
Aisha Zaheer

Design
Ashna Varma
Aisha Zaheer

Production
CDS (Middlesex University)

Image + photo credits

Cover image:
Ausra Kamicaityte

Issn
2398-4171

Website
draft-magazine.com

Twitter
@InteriorsMDX

Facebook
Interiors MDX

Instagram
@InteriorsMDX

Interior Architecture Year One Students
Michael Bustillos Salazar
Myasara Daaboul
Phinolla Glenn
Joao Miguel Guerreiro Ferreira
Didem Gunes
Elif Gulbayrak
Charles Hoar
Sharife Ibrahim
Mahaylia Irish
Viktorija Marcinkeviciute
Sabah Mohamed
Sareh Sarvar
Kowshikan Sivalingam
Jasmine Tetteh
Gabriella Viltaki

Interior Architecture Year Two Students
Zaha Al Jbouri
Daniel Brown
Savanna Nelson-Murray
Rehanna Cameron
Cheryse Canoville
Sylvia Chlebowicz
Elena Petrova Chomuklieva
Jurate Cibulske
Chay Clohessy
Marieta Correia Ca
Vanessa Dos Santos Sousa
Lucinda Hekneby
Lucija Michalska
Anastasija Luciva
Evy Mansour
Michaela Ohenien
Pishoi Phillips
Phatsara Phueng-Ain
Claire Robey
Bethany Williams
Chanel Wu
Rita Zavratchiyka
Beatriz Olivera Camello
Filuzio Soeiro Da Silva

Interior Architecture Year Three Students
Rasha Al-Dori
Seda Altundal
Ben Arscott
Sameeha Bashir
Nancy El-Mahdi
Al-Nadlim Feysal Axmed
Magnus Fines-Conqule
Neha Halai
Marynelle Jacob
Mahsa Khaki
Sheiddasadat Khamooshi
Safa Sayeed Khan
Kornelija Kopustaite
Shu Ling Chai
Karolina Magdalena Charewicz
Shermin Myumuyun
Evangeline Osuji
Patrycja Poklek
Shakera Rahman
Polina Savinova
Lih Ning Tee
Deliyana Tsankova
Pei San Goh
Chi Xin Ho
Minho Ju
Ausra Kamicaityte
Dickson Kong
Shiang Qian Lim
Iaina Ven Zie Low
Wafaa Najjihah Binti Mohd Halim
Tian Chun Ong
Dyna Russel Rabanal
Edlyn Xin Rou Tan
Cai Ye
Agnes Shu Yuan Yeo

Interior Architecture Tutors
Programme Leader:
Francesca Murialdo

Francesca Avian
Gavin Challand
James Christian
Rebecca Disney
David Fern
Susan Ginsburg
Naomi House
Thomas Kendall
Ben Sinclair-Macdonald
Peter Thomas
Ceri Williams

Interior Design Year one Students
Mahbuba Ahad
Melis Akpinar
Mustafa Allah Ditta
Temitope Allison
Maha Alnuaimi
Aleksandrs Antonovs
Bethany Aylward
Natalie Bardy
Barbarah Sofia Chiu Fonseca Cardos
Nazifa Chowdhury
Anna Ciesielska
Chloe Dixon
Monika Dziegielewska Maka
Daniel Rui Ferreira Da Silva Rei
Maria Gedlike
Deryna Dilcem Gul
Filip Jaber
Derya Dilcem Gul
Filip Jaber
Julia Keck
Yazmin Khan
Marissa Miltiadous
Christine Omorere
Stephanie Protopapa
Andreea Raileanu
Ida Sahlberg
Mansi Pravin Sakhiya
Alban Sallhi
Samin Souri
Shafaq Sultana
Shannon Sutton
Klaudia Zboowska

Interior Design Year Two Students

Somayeh Afrazikalvir
Steve Andrawes
Cristina Ariza Baeza
Mariama Bah
Georgla Barton
Emanuela Buiza
Stjepan Cagalj
Emilia Comanescu
Jovita Dabasinskaite
Eleonora Ekholm
Hayley Forta
Irina Goldtmane
Joseph Hall
Kalleigh Harewood
Savanah Hyland
Weronika Jadach
Laurine Lalonde
Folsade Lanahun
Geraldine Lopez Cuaican
Oluwadamilola Matiluko
Alexandru Miron
Alicja Malgorzata Moskal
Lera Nabokina
Antonliya Peneva
Samira Parvin Sadia
Pooja Rani Kaur
Laila Sarr
Rochelle Sinclair
Tailla Singer
Lara Sodan
Misha Sohail
Victoria Turcan
Jamila Kuna
Anisha Uddin
Viktoria Venetsieva
Jana Veselova
Gizem Yavuz
Rahma Yusuf

Interior Design Year Three Students

Valerie Akano
Vaad Asl Sharhani
Rosa Angela Bonetti
Cheuk Tung Fung
Daniela Hurmuzache
Nhu Helen Dang
Reema Dhokia
Kelsey Dorrian-Godfrey
Patricija Gadliauskaite
Silvia Jagdey
Anitha Kamalanathan
Estefania Lucila Becerril Hernandez
Viktorija Kilypaite
Aleksandra Renata Kmiecik
Karolina Kwiatkowska
Kin Lok Lau
Mohanpriya Mahendran
Mariana Marques Da Silva
Aneesah Masoud
Jessica Meyers
Milana Milcanovska
Anwar Omer
Anita Rai
Priscilla Rizzieri
Erna Sejdovic
Fareeda Sirajzadeh
Kotryna Skrickyte
Zhane Smith
Hanna Stauch

Roxanne Stone
Gabija Villute
Alicia Waknell
Hafssa Zarrai

Interior Design Tutors
Programme Leader:
Jon Mortimer

Francesca Avian
Julius Augustinavicius
Camille Azria
Gavin Challand
Jules Chamberlain
David Fern
Naomi House
Peter Thomas
Ben Sinclair-MacDonald
Susan Ginsburg
Fiona Walker
Michael Westthorp

Interiors MA Students

Chen-Han Yu
Mel Aoki
Saciide Filiz Bilaloglu
Menseke Celik
Mika Okazaki
Samar Abbas Fadhil Ghaffoori
Sahar Paknahadjabarooti
Emma Ashton
Ana Popovici
Angali Rajmohan
Bounthavy Malavong
Eunji Luna Kim
Joely Marselle Peña Jimenez
Mehrnoush Pouryan
Noureddin Abdelhalim
Thap Aksone Jack Phunavongxay
Wan Nurul Ashikin Romlee
Sinclair English
Chin Fox Wong
Tanvi Ajay Agrawal
Simran Naresh Khatri
Djamila Indira Coata Sanches Correia

Interiors MA Tutors
Programme Leader:
Jason Scoot

Gareth Williams
Parnian Akhavan-Tabib
Tony Side
David Fern

Graduate Academic Assistants
Aisha Zaheer
Ashna Varma

HKU SPACE - Hong Kong Tutors
Arthur Lo
Judy Cheung
David Fern (Link Tutor)

Director of Programmes
Interior Architecture + Design:
David Fern

