

# Middlesex University Research Repository:

an open access repository of  
Middlesex University research

<http://eprints.mdx.ac.uk>

Okoro, Efeosasere Moibi, 2014. A study of different representation conventions during investigatory sensemaking. Available from Middlesex University's Research Repository.

---

## Copyright:

Middlesex University Research Repository makes the University's research available electronically.

Copyright and moral rights to this thesis/research project are retained by the author and/or other copyright owners. The work is supplied on the understanding that any use for commercial gain is strictly forbidden. A copy may be downloaded for personal, non-commercial, research or study without prior permission and without charge. Any use of the thesis/research project for private study or research must be properly acknowledged with reference to the work's full bibliographic details.

This thesis/research project may not be reproduced in any format or medium, or extensive quotations taken from it, or its content changed in any way, without first obtaining permission in writing from the copyright holder(s).

If you believe that any material held in the repository infringes copyright law, please contact the Repository Team at Middlesex University via the following email address:

[eprints@mdx.ac.uk](mailto:eprints@mdx.ac.uk)

The item will be removed from the repository while any claim is being investigated.

A STUDY OF  
DIFFERENT REPRESENTATION CONVENTIONS  
DURING INVESTIGATORY SENSEMAKING

---



A THESIS  
SUBMITTED TO THE SCHOOL OF SCIENCE AND TECHNOLOGY,  
MIDDLESEX UNIVERSITY, LONDON,  
IN PARTIAL FULFILMENT OF THE REQUIREMENTS  
FOR THE DEGREE OF  
MASTERS OF SCIENCE (BY RESEARCH)

EFEOSASERE MOIBI OKORO  
DECEMBER, 2013

Supervisor: Dr. Simon Attfield

Programme Leader: Dr. Kai Xu

# Abstract

## Background

During the process of conducting investigations, users structure information externally to help them make sense of what they know, and what they need to know. Software-based visual representations may be a natural place for doing this, but there are a number of types of information structuring that might be supported and hence designed for. Further, there might be important differences in how well different representational conventions support sensemaking. There are questions about what type of representational support might allow these users to be more effective when interacting with information.

## Aim

To explore the impact that different types of external representational structuring have on performance and user experience during intelligence type investigations. Intelligence analysis represents a difficult example domain where sensemaking is needed. We have a particular interest in the role that timeline representations might play given evidence that people are naturally predisposed to make sense of complex social scenarios by constructing narratives. From this we attempt to quantify possible benefits of timeline representation during investigatory sensemaking, compared with argumentation representation.

## Method

Participants performed a small investigation using the IEEE 2011 VAST challenge dataset in which they structured information either as a timeline, an argumentation or as they wished (freeform). 30 participants took part in the study. The study used three levels of a between participants independent variable of representation type. The dependent variables were performance (in terms of recall, precision efficiency and understanding) and user experience (in terms of cognitive load, engagement and confidence in understanding).

## Result

The result shows that the freeform condition experienced a lower cognitive load than the other two: timeline and argument respectively. A post hoc exploratory analysis was conducted to better understand the information behaviour and structuring activities across conditions and to better understand the types of structuring that participants perform in the freeform condition. The analysis resulted in an Embedded Representational Structuring

Theory (ERST) that helps to characterise and describe representations primarily in terms of their elements and their relations.

## Conclusion

The results suggest that: (a) people experienced lower cognitive load when they are free to structure information as they wish, (b) during their investigations, they create complex heterogeneous representations consisting of various entities and multiple relation types and (c) their structuring activities can be described by a finite set of structuring conventions.

# Declaration

I, Efeosasere Moibi Okoro, hereby declare that this thesis entitled, “A Study of Different Representation Conventions during Investigatory Sensemaking” is my own work, and that all the sources I have used or quoted have been indicated or acknowledged by means of completed reference

---

Efeosasere Moibi Okoro

# Dedication

My Mother

Mrs. Abigail U. Okoro

*“My mother was the making of me.*

*She was so true, so sure of me, and I felt I had some one to live for,*

*some one I must not disappoint”* Thomas Edison

# Acknowledgement

This thesis has been the most enormous but yet the most interesting “thing” I have ever had to do and there would have been no way I would have been able to do this without the help of the following persons.

I am pleased to thank Dr. Simon Attfield who acted as my supervisor throughout the course of this thesis, for his endless efforts and encouragements. Thank you for pushing me beyond my very self and believing in me.

To Neesha, Chris and Tinni who contributed greatly to the construction of the study of this thesis and to Professor William Wong for his great feedbacks, advice and interest in my work. Also not forgetting my very good colleagues; Ivo, Phong, Young, Rick and Joshua who have been with me from the start of this course till finish. I really appreciate you all.

To Damien, Sogie, Dorcas, Anthony and Nil who have been family to me from my undergraduate days, I am very grateful for your friendship till this day and to Victoria “Na-na” for all your encouragements.

To Dad, Mum and Ese for all your emotional support, encouragements and motivations. I would not have asked for a better family and to God Almighty for your grace and faithfulness, You see my heart, I am indeed grateful *“Not unto me, Oh Lord, not unto me”*.

## Publications related to this thesis

Chapin, L., Attfield, S., & **Okoro, E. M.** (2013). Predictive Coding, Storytelling and God: Narrative Understanding in e-Discovery. Presented at the DESI V Workshop, Consiglio Nazionale delle Ricerche, Rome, Italy. Retrieved from <http://www.umiacs.umd.edu/~oard/desi5/Chapin-final.pdf>



# Table of contents

<b>1</b>	<b>INTRODUCTION AND BACKGROUND</b>	<b>3</b>
1.1	BACKGROUND	3
1.2	PROPOSED STUDY	3
1.3	THESIS OUTLINE	5
<b>2</b>	<b>LITERATURE REVIEW</b>	<b>7</b>
2.1	SENSEMAKING	7
2.1.1	THE FRAME AND THE DATA FRAME THEORY OF SENSEMAKING	9
2.1.2	REPRESENTATION	10
2.1.3	RE-REPRESENTATION	12
2.2	ARGUMENT STRUCTURING AND MAPPING	13
2.2.1	WHATELY DIAGRAMMING METHOD	14
2.2.2	WIGMORE'S CHART	15
2.2.3	TOULMIN DIAGRAMMING METHOD	18
2.3	NARRATIVE, ITS SIGNIFICANCE AND CONSTRUCTION	20
2.4	HYBRID APPROACH	22
2.5	CONCLUSION	23
<b>3</b>	<b>STUDY METHOD</b>	<b>25</b>
3.1	OVERVIEW	25
3.2	DESIGN	26
3.2.1	RECALL:	26
3.2.2	PRECISION:	27
3.2.3	TASK DURATION:	27
3.2.4	COGNITIVE LOAD:	27
3.2.5	UNDERSTANDING:	29
3.2.6	CONFIDENCE:	29
3.2.7	ENGAGEMENT:	30
3.3	PARTICIPANTS	30
3.4	MATERIALS	31
3.5	PROCEDURE	32

3.5.1	TRAINING	32
3.5.2	TASK	33
3.5.3	DATA COLLECTION	34
3.5.4	DEBRIEF	34
<b>4</b>	<b>STUDY FINDINGS</b>	<b>36</b>
<b>4.1</b>	<b>TEST OF SIGNIFICANCES AND EFFECT SIZE</b>	<b>39</b>
4.1.1	DURATION	39
4.1.2	PRECISION AND RECALL COMPARISON	40
4.1.3	UNDERSTANDING	43
4.1.4	CONFIDENCE	44
4.1.5	COGNITIVE LOAD	45
4.1.6	ENGAGEMENT	47
<b>4.2</b>	<b>SUMMARY OF THE STUDY FINDINGS</b>	<b>48</b>
<b>5</b>	<b>POST HOC EXPLORATORY ANALYSIS</b>	<b>50</b>
<b>5.1</b>	<b>OVERVIEW</b>	<b>50</b>
<b>5.2</b>	<b>ANALYSING AND COMPARING REPRESENTATIONAL STRUCTURING ACROSS CONDITIONS OVER TIME</b>	<b>50</b>
5.2.1	CODING SCHEME	51
5.2.2	ACTIVITY TIMELINE GRID	52
5.2.3	EXPLORING USER-GENERATED REPRESENTATIONS IN INVESTIGATORY SENSEMAKING TASKS	55
<b>5.3</b>	<b>UNDERSTANDING THE EMBEDDING OF STRUCTURAL CONVENTIONS IN FREEFORM CONDITIONS</b>	<b>64</b>
5.3.1	THE FUNCTIONAL THEORY OF EMBEDDED REPRESENTATIONAL STRUCTURING (ERST)	64
<b>6</b>	<b>DISCUSSION AND CONCLUSION</b>	<b>84</b>
<b>6.1</b>	<b>RESULT SUMMARY AND EXPLANATION</b>	<b>84</b>
<b>6.2</b>	<b>EMBEDDED REPRESENTATIONAL STRUCTURE THEORY (ERST)</b>	<b>85</b>
6.2.1	DESIGN SUGGESTIONS	86
<b>6.3</b>	<b>STUDY LIMITATIONS</b>	<b>86</b>
<b>6.4</b>	<b>CONCLUSION</b>	<b>87</b>
<b>7</b>	<b>BIBLIOGRAPHY</b>	<b>89</b>
<b>8</b>	<b>APPENDICES</b>	<b>99</b>
<b>8.1</b>	<b>APPENDIX A: CONSENT FORM AND QUESTIONNAIRE</b>	<b>99</b>
8.1.1	CONSENT FORM	99

8.1.2	BACKGROUND INFORMATION FORM	102
8.1.3	CERTAINTY QUESTIONNAIRE	103
8.1.4	ENGAGEMENT QUESTIONNAIRE	105
<b>8.2</b>	<b>APPENDIX B: STUDY PRESENTATION SLIDES</b>	<b>107</b>
8.2.1	ARGUMENT CONDITION PRESENTATION	107
8.2.2	TIMELINE CONDITION PRESENTATION	109
8.2.3	FREEFORM CONDITION PRESENTATION	110
<b>8.3</b>	<b>APPENDIX C: SPSS OUTPUT</b>	<b>111</b>
8.3.1	FREQUENCIES	111
8.3.2	HISTOGRAMS	112
8.3.3	KRUSKAL-WALLIS TEST FOR ALL DEPENDENT VARIABLES	116
8.3.4	MANN-WHITNEY TEST FOR THE ARGUMENT (1.0) AND FREEFORM (2.0) CONDITIONS	118
8.3.5	MANN-WHITNEY TEST FOR ARGUMENT (1.0) AND TIMELINE (3.0) CONDITIONS	120
8.3.6	MANN-WHITNEY TEST FOR FREEFORM (2.0) AND TIMELINE (3.0) CONDITIONS	122
8.3.7	KRUSKAL-WALLIS TEST FOR STRUCTURAL ACTIVITIES	124
8.3.8	KRUSKAL-WALLIS TEST FOR INFORMATION SEEKING AND BEHAVIOUR ACTIVITIES	125
<b>8.4</b>	<b>APPENDIX D: ACTIVITY TIMELINE GRIDS</b>	<b>126</b>
<b>8.5</b>	<b>APPENDIX E: OTHER RELATIONS EXAMPLES</b>	<b>137</b>
8.5.1	OTHER INFORMATION OBJECT SURROGATE RELATION EXAMPLES	137
8.5.2	OTHER TIMELINE RELATION EXAMPLES	139
8.5.3	OTHER JUSTIFICATION RELATION EXAMPLES	141

# Table of figures

FIGURE 2-1: NOTIONAL MODEL OF ANALYST SENSEMAKING FROM PIROLI & CARD (2005)	8
FIGURE 2-2: SIMPLIFIED SENSEMAKING PROCESS	9
FIGURE 2-3: DATA FRAME THEORY FOR SENSE MAKING FROM KLEIN ET AL. (2006)	10
FIGURE 2-4: LEARNING LOOP COMPLEX THEORY OF SENSEMAKING	12
FIGURE 2-5: WHATELY DIAGRAMMING FROM MACAGNO ET AL (2007, P.13)	15
FIGURE 2-6: PART OF WIGMORE'S CHART FOR COMMONWEALTH V. UMILIAN FROM GOODWIN AND FISHER (2000 P.226)	16
FIGURE 2-7: WIGMORE'S CHART SYMBOLS, LINES AND THEIR INTERPRETATION FROM WIGMORE (1913, PP. 751–753)	16
FIGURE 2-8: EXAMPLE OF AN ARGUMENT USING TOULMIN MODEL (TOULMIN ET AL., 1979 P.77)	19
FIGURE 2-9: COMBINING NARRATIVE AND ARGUMENT, THE HYBRID MODEL FROM BEX (2010 P.2)	23
FIGURE 3-1: MEAN DURATION JUDGMENT RATIO IN THE PROSPECTIVE AND RETROSPECTIVE PARADIGMS AS A FUNCTION OF COGNITIVE LOAD. ERROR BARS ARE THE STANDARD ERRORS OF THE MEAN FROM (BLOCK ET AL. 2010)	28
FIGURE 3-2: GENDER DISTRIBUTION ACROSS CONDITIONS	30
FIGURE 3-3: NATIVE AND NON-NATIVE ENGLISH SPEAKERS DISTRIBUTION ACROSS CONDITIONS	31
FIGURE 3-4: ARGUMENT STRUCTURE USED BY THE PARTICIPANTS FOR THE ARGUMENT CONDITION	32
FIGURE 4-1: COGNITIVE LOAD DISTRIBUTION AND MEAN AND MEAN	36
FIGURE 4-2: ENGAGEMENT DISTRIBUTION	
FIGURE 4-3: UNDERSTANDING DISTRIBUTION AND MEAN	37
FIGURE 4-4: BAR GRAPH SHOWING MEDIAN DURATION IN MINUTES WITH ERROR BARS INDICATING THE MEDIAN ABSOLUTE DEVIATION	39
FIGURE 4-5: BAR GRAPH SHOWING MEDIAN PERCENTAGE RECALL AND PRECISION VALUES WITH ERROR BARS INDICATING THEIR MEDIAN ABSOLUTE DEVIATION	40
FIGURE 4-6: SCATTERPLOT SHOWING THE F MEASURE VALUES FOR ALL PARTICIPANTS PER CONDITION	41
FIGURE 4-7: BAR GRAPH SHOWING MEDIAN UNDERSTANDING WITH ERROR BARS INDICATING THE MEDIAN ABSOLUTE DEVIATION	43
FIGURE 4-8: BAR GRAPH SHOWING MEDIAN CONFIDENCE WITH ERROR BARS INDICATING THE MEDIAN ABSOLUTE DEVIATION	44
FIGURE 4-9 BAR GRAPH SHOWING MEDIAN COGNITIVE LOAD WITH ERROR BARS INDICATING THE MEDIAN ABSOLUTE DEVIATION	45
FIGURE 4-10: BAR GRAPH SHOWING THE MEDIAN ENGAGEMENT WITH ERROR BARS INDICATING THE MEDIAN ABSOLUTE DEVIATION	47
FIGURE 5-1: SAMPLE ACTIVITY TIMELINE GRID	53
FIGURE 5-2: CLUSTERED BAR CHART SHOWING THE AVERAGE PERCENTAGE TIME FOR PERFORMING INFORMATION SEEKING AND BEHAVIOUR ACTIVITIES ACROSS CONDITIONS	53
FIGURE 5-3: CLUSTERED BAR CHART SHOWING THE AVERAGE PERCENTAGE TIME FOR PERFORMING STRUCTURAL ACTIVITIES ACROSS CONDITIONS	54

FIGURE 5-4: REPRESENTATION SHOWING ONE INFORMATION OBJECT	56
FIGURE 5-5: SYNTAX TREE SHOWING ONE INFORMATION OBJECT	56
FIGURE 5-6: REPRESENTATION SHOWING TWO INFORMATION OBJECTS	57
FIGURE 5-7: SYNTAX TREE SHOWING TWO INFORMATION OBJECTS	57
FIGURE 5-8: REPRESENTATION SHOWING ONE INFORMATION OBJECT SURROGATE AND ONE INFORMATION OBJECT	58
FIGURE 5-9: SYNTAX TREE SHOWING ONE INFORMATION OBJECT SURROGATE AND ONE INFORMATION OBJECT	58
FIGURE 5-10: REPRESENTATION SHOWING TWO INFORMATION OBJECT SURROGATES	59
FIGURE 5-11: SYNTAX TREE SHOWING TWO INFORMATION OBJECT SURROGATES	59
FIGURE 5-12: REPRESENTATION SHOWING MULTIPLE INFORMATION OBJECTS SURROGATES	60
FIGURE 5-13: REPRESENTATION SHOWING MULTIPLE INFORMATION OBJECTS SURROGATES IN A THEME	60
FIGURE 5-14: SYNTAX TREE SHOWING MULTIPLE INFORMATION OBJECTS SURROGATES AND A THEME	61
FIGURE 5-15: REPRESENTATION SHOWING COLOUR CODED THEMES	61
FIGURE 5-16: SYNTAX TREE SHOWING A TIMELINE RELATION EMBEDDED IN A THEME	62
FIGURE 5-17: SYNTAX TREE SHOWING ALL THE CONSTITUENTS OF THE USER'S REPRESENTATION	62
FIGURE 5-18: INFORMATION OBJECT SURROGATE RELATION WITH GIST AND SOURCE ELEMENTS CREATED BY PARTICIPANT 16	69
FIGURE 5-19: SAMPLE INFORMATION OBJECT (DOCUMENT) WHEN OPENED	69
FIGURE 5-20: INFORMATION OBJECT SURROGATE RELATION WITH GIST, SOURCE AND DATE ELEMENTS CREATED BY PARTICIPANT 9	70
FIGURE 5-21: INFORMATION OBJECT SURROGATE RELATION WITH GIST, SOURCE AND DATE ELEMENTS CREATED BY PARTICIPANT 25	70
FIGURE 5-22: INFORMATION OBJECT SURROGATE RELATION WITH GIST, SOURCE AND DATE ELEMENTS CREATED BY PARTICIPANT 20	71
FIGURE 5-23: TIMELINE RELATION WITH TITLE, DATE, GIST AND SOURCE ELEMENTS CREATED BY PARTICIPANT 3	72
FIGURE 5-24: TIMELINE RELATION WITH DATE , GIST AND SOURCE ELEMENTS CREATED BY PARTICIPANT 25	73
FIGURE 5-25: TIMELINE RELATION WITH TITLE, DATE AND SOURCE ELEMENTS CREATED BY PARTICIPANT 7	73
FIGURE 5-26: THEMED GROUPING RELATION CREATED BY PARTICIPANT 9 USING LINES	74
FIGURE 5-27: THEMED GROUPING RELATION CREATED BY PARTICIPANT 7 USING COLOUR	75
FIGURE 5-28: EXPLANATION RELATION WITH TWO INFORMATION OBJECT SURROGATES CREATED BY PARTICIPANT 3	77
FIGURE 5-29: EXPLANATION RELATION WITH THREE INFORMATION OBJECT SURROGATES CREATED BY PARTICIPANT 3	78
FIGURE 5-30: JUSTIFICATION RELATION WITH A CLAIM AND EVIDENTIAL SUPPORT CREATED BY PARTICIPANT 14	80
FIGURE 5-31: SAMPLE OF THE INFORMATION OBJECT'S CONTENT USED BY PARTICIPANT 14 TO JUSTIFY THEIR CLAIM	80
FIGURE 5-32:JUSTIFICATION RELATION WITH SINGLE CLAIM AND MULTIPLE EVIDENTIAL SUPPORT CREATED BY PARTICIPANT 14	81

FIGURE 5-33: SAMPLE INFORMATION OBJECT USED BY PARTICIPANT 14 TO PROVIDE SUPPORT TO THEIR CLAIM	81
FIGURE 8-1: AN INFORMATION OBJECT SURROGATE RELATION WITH TITLE AND DATE ELEMENTS CREATED BY PARTICIPANT 14	137
FIGURE 8-2: AN INFORMATION OBJECT SURROGATE RELATION WITH TITLE, SOURCE AND DATE ELEMENTS CREATED BY PARTICIPANT 7	138
FIGURE 8-3: AN INFORMATION OBJECT SURROGATE RELATION WITH TITLE, GIST, SOURCE AND DATE ELEMENTS CREATED BY PARTICIPANT 3	138
FIGURE 8-4: A TIMELINE RELATION WITH TITLE, DATE AND GIST ELEMENTS CREATED BY PARTICIPANT 14	139
FIGURE 8-5: A TIMELINE RELATION WITH DATE , GIST AND SOURCE ELEMENTS CREATED BY PARTICIPANT 9	139
FIGURE 8-6: A TIMELINE RELATION WITH DATE , GIST AND SOURCE ELEMENTS CREATED BY PARTICIPANT 20	140
FIGURE 8-7: JUSTIFICATION RELATION WITH A SINGLE CLAIM AND TIMELINE RELATION AS EVIDENTIAL SUPPORT	141
FIGURE 8-8: A JUSTIFICATION RELATION CREATED BY PARTICIPANT 18	142
FIGURE 8-9: A JUSTIFICATION RELATION CREATED BY PARTICIPANT 29	142

# Table of tables

TABLE 1-1: DEPENDENT VARIABLES AND THEIR PREDICTED HYPOTHESIS DIRECTION	4
TABLE 2-1: EVIDENCE LIST FOR COMMONWEALTH V. UMILIAN CASE FROM WIGMORE (1913, PP. 757–758)	17
TABLE 2-2: PERCENTAGE OF SUBJECTS CHOOSING A VERDICT OF GUILTY OF MURDER BY PROSECUTION AND DEFENCE ORDER CONDITIONS FROM PENNINGTON AND HASTIE (1991).	21
TABLE 3-1: THE DOCUMENT SERIAL NUMBERS FOR THE RELEVANT AND IRRELEVANT DOCUMENTS USED IN THE STUDY	33
TABLE 4-1: THE STANDARD VALUES FOR EFFECT SIZE FROM KOJI (2013)	38
TABLE 4-2: THE PERCENTAGE OF HIGH AND LOW PERFORMING PARTICIPANTS PER CONDITION	42
TABLE 4-3: THE CONDITIONS AND THEIR TEST TAILS FOR THE MANN-WHITNEY TESTS	46
TABLE 4-4: SUMMARY OF KRUSKAL-WALLIS TEST RESULTS	48
TABLE 4-5: SUMMARY OF THE MANN-WHITNEY TEST AND EFFECT SIZE RESULTS	48
TABLE 5-1: INTERPRETIVE AND OBJECTIFIABLE CODES USED FOR VIDEO PROTOCOL ANALYSIS	51
TABLE 5-2: PRODUCTION RULE FOR SYNTAX TREE SHOWING ONE INFORMATION OBJECT	56
TABLE 5-3: PRODUCTION RULE FOR SYNTAX TREE SHOWING ONE INFORMATION OBJECT	57
TABLE 5-4: PRODUCTION RULE FOR SYNTAX TREE SHOWING ONE INFORMATION OBJECT SURROGATE AND ONE INFORMATION OBJECT	58
TABLE 5-5: PRODUCTION RULE FOR SYNTAX TREE SHOWING TWO INFORMATION OBJECT SURROGATES	59
TABLE 5-6: PRODUCTION RULE FOR SYNTAX TREE SHOWING MULTIPLE INFORMATION OBJECTS SURROGATES AND A THEME	61
TABLE 5-7: PRODUCTION RULE FOR SYNTAX TREE SHOWING A TIMELINE RELATION EMBEDDED IN A THEME	62
TABLE 5-8: PRODUCTION RULE FOR SYNTAX TREE SHOWING ALL THE CONSTITUENTS OF THE USER'S REPRESENTATION	62
TABLE 5-9: RELATIONS AND ELEMENTS OF THE ERST	67
TABLE 5-10: INFORMATION OBJECT SURROGATE RELATION AND ELEMENTS	67
TABLE 5-11: TIMELINE RELATION AND ELEMENTS	72
TABLE 5-12: THEMED GROUPING RELATION AND ELEMENTS	74
TABLE 5-13: EXPLANATION RELATION AND ELEMENTS	76
TABLE 5-14: JUSTIFICATION RELATION AND ELEMENTS	79
TABLE 5-15: THE RELATION FREQUENCY AMONG PARTICIPANTS	82

# Table of equations

EQUATION 3-1: FORMULAE FOR MEASURING PARTICIPANTS RECALL	26
EQUATION 3-2: FORMULAE FOR MEASURING PARTICIPANTS PRECISION	27
EQUATION 3-3: FORMULAE FOR CALCULATING DURATION JUDGEMENT	28
EQUATION 4-1: THE EFFECT SIZE FORMULA FOR A MANN-WHITNEY TEST FROM KOJI (2013)	38
EQUATION 4-2: THE FORMULA TO CALCULATE F MEASURE	41





# Chapter 1

## Introduction and Background

# Introduction and background

## 1.1 Background

During the process of conducting investigations, users structure information externally to help them make sense of what they know, and what they need to know. Software-based visual representations may be a natural place for doing this, but there are a number of types of information structuring that might be supported and hence designed for. Further, there might be important differences in how well different representational conventions support sensemaking. There are questions about what type of representational support might allow these users to be more effective when interacting with information.

Literature points us to two dominant representation approaches; narrative and argumentation. Cognitive psychology research in juror decision making by Pennington & Hastie (1986, 1991, 1992) and reports and commentary from the legal industry by McElhaney (2012) and Hamilton & Chapin (2012) provide evidence that people are naturally predisposed to make sense of complex social scenarios by constructing narratives. On the other hand, the argumentation approach, was made popular by Wigmore (1913) and Toulmin (2003) and there is an argued point that argument structuring improves critical thinking (Twardy, 2003; van Gelder, 2009) because one of the components of critical thinking is to produce arguments, comprehend their logical structure and examine their strength and weakness (Sbarski et al., 2008; Toulmin, Rieke, & Janik, 1979).

## 1.2 Proposed study

The present study sets out to explore and compare the impact that different types of external representational structuring have on performance and user experience during intelligence type investigations. Intelligence analysis represents a difficult example domain where sensemaking is expedient (Greitzer, 2005; Heuer, 1999). On the basis of previous research, given evidence that people are naturally predisposed to make sense of complex social scenarios by constructing exploratory narratives, we hypothesised that given the role that narrative play, if people are given a timeline representation, they will exhibit better performance and experience better user experience when performing sensemaking task than when they are given an argumentation representation (see table 1-1). We also have

## Chapter 1 Introduction and background

included a freeform representation in order to see what people would naturally do in a sensemaking task like this. If the hypothesis is right, then the benefits of timeline in relation to argumentation should be quantifiable.

In order to test the hypothesis, a study was set up with representation convention (with three levels; argumentation, timeline and freeform) as the independent variable and performance and user experience as the dependent variables. The performance measures were: recall, precision, efficiency and understanding while the user experience measures were: cognitive load, engagement and confidence in participants understanding. Participants performed a small investigation with a 'ground truth' collection in which they searched, reviewed and organised selected information into representational conventions that are either argumentational, chronological or in freeform (which is not constrained to any representational convention).

Variable type	Dependent Variable	Predicted hypothesis direction
Performance	Recall	Timeline > Argument
	Precision	Timeline > Argument
	Understanding	Timeline > Argument
User experience	Confidence	Timeline > Argument
	Cognitive load	Timeline < Argument
	Engagement	Timeline > Argument

Table 1-1: Dependent variables and their predicted hypothesis directions

Table 1-1 shows the dependent variables and their predicted hypothesis directions. We predict that participants in the timeline condition would exhibit better performance (in terms of recall, precision and understanding) and experience better user experience (in terms of confidence, cognitive load and engagement) than the participants in the argumentation condition.

## 1.3 Thesis outline

The remainder of this thesis is outlined as follows:

**Chapter 2** explores literature in the subject of sensemaking and also narrative and argumentation structuring.

**Chapter 3** describes the study that sets out to explore and compare the impact that different types of external representational structuring have on performance and user experience during intelligence type investigations.

**Chapter 4** presents the results of the study

**Chapter 5** presents a post hoc analysis that, (i) analyses and compares representational structuring across conditions over time and (ii) describes and provides the Embedded Representational Structuring Theory (ERST) for characterising and describing complex heterogeneous representations primarily in terms of their relations and elements.

**Chapter 6** discusses the findings from the study and the value of the ERST. It also provides design suggestions for sensemaking tools.

# Chapter 2

## Literature Review

## Literature review

### 2.1 Sensemaking

Sensemaking is an on-going process (G. Klein, Phillips, & Peluso, 2007; Russell, Stefik, Pirolli, & Card, 1993; Kirsh, 2009; Pirolli & Card, 2005; Baber, Attfield, Wong, & Rooney, 2013; Zhang, Qu, Giles, & Song, 2008). Zhang et al (2008) describes it as a complicated one which involves the twin hands of information seeking and comprehension. Klein et al. (2007) describe sensemaking as constructing meaning from data. However, Baber et al. (2013) added that sensemaking is also inclusive of background knowledge. That is, in the words of Baber and colleagues “... *a process through which data meet background knowledge...*” (Baber et al., 2013, p. 125). Sensemaking is further described as the deliberate effort to understand events (Klein et al., 2007) mostly when one is faced with a new event in unfamiliar situations and their current knowledge is inadequate (Zhang et al, 2008).

An example domain where sensemaking is expedient is intelligence analysis. Intelligence analysis is a cognitively complex task (Greitzer, 2005; Heuer, 1999). It is described as among the more difficult problem domains because it is connected to decisions about human intentions and actions which are often unpredictable. Professionals of this domain are confronted daily with vast amount of incomplete, inconclusive and ambiguous, homogenous and heterogenous data in order to determine the likelihood of an undesirable event (Baber et al., 2013; Thomas & Cook, 2005; Heuer, 1999). In order to do this, they usually will go through a set of sense making tasks (Thomas & Cook, 2005; Pirolli & Card, 2005).

The most recognised model for sensemaking in the intelligence analysis domain is the notional model of analyst sensemaking (Pirolli & Card, 2005) (see figure 2-1). The model resulted from a cognitive task analysis and verbal protocol analysis with the aim of providing an empirical understanding of the structure and processes involved in intelligence analysis (Pirolli & Card, 2005).

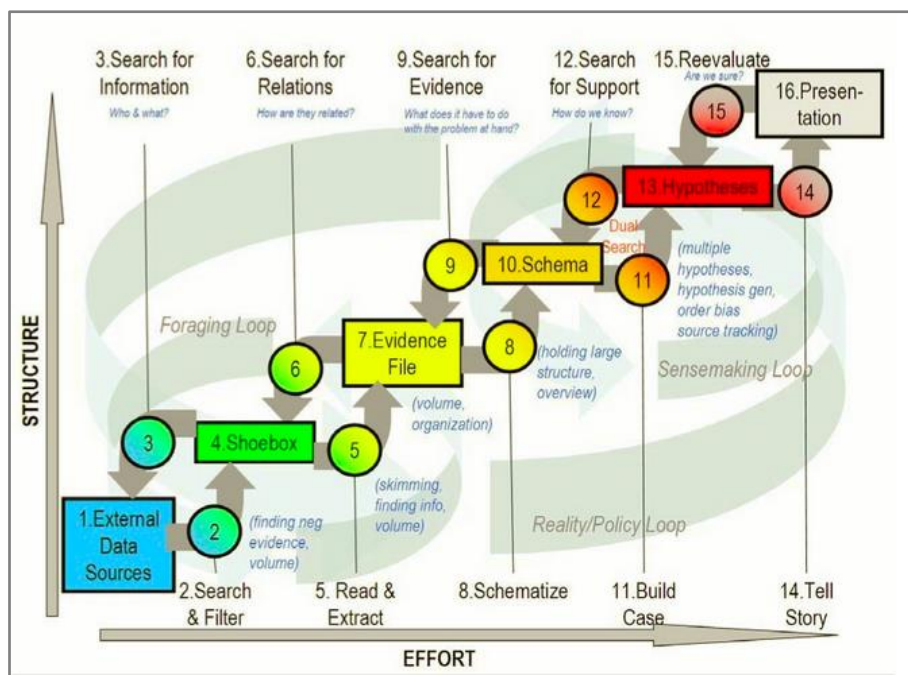

Figure 2-1: Notional model of analyst sensemaking from Pirolli & Card (2005)

The overall process of the notional model of analyst sensemaking is an iterative one organised into two major loops of activities: *foraging* and *sensemaking* loops that includes both a *bottom-up* and *top-bottom* information process. The rectangles and circles in figure 2-1 represent *data flow* and *process flow* respectively. They flow from raw data to presentable information that can be communicated via stories. These data and process flows are further arranged by their degree of effort and the degree of structuring involved. These are presented in the horizontal and vertical axis respectively.

The *external data source* indicates raw evidence (data) often both homogenous and heterogeneous. The “*shoe-box*” is described as the relevant subset of the *external data* for processing. The *evidence file* contains a small extract from items in the relevant subset. The *schemas* are the re-organised form of the information (such as diagrams, maps etc.) (Klein, Moon, & Hoffman, 2006) which can be internal as well as external (Russell et al., 1993) so conclusions can easily be drawn. *Hypotheses* are the provisional organisation of those conclusions with supporting evidence and finally, the data flow ends with a *presentation*.

The *foraging loop* includes those processes directed at information seeking (searching and filtering) such as the review and extracting of information and the identification of relations. On the other hand the *sensemaking loop* includes the schematisation of the information ‘forged’ from the foraging process, the building of a case, the inclusion of support to increase certainty and storytelling. The model is simplified by a linear diagram in Pirolli & Card (2005) work (see figure 2-2). Here, the sensemaking task consists of information gathering, re-



representation of the information in a schema that helps the analytical process, the manipulation of the representation formed to develop insight and the creation of a product.

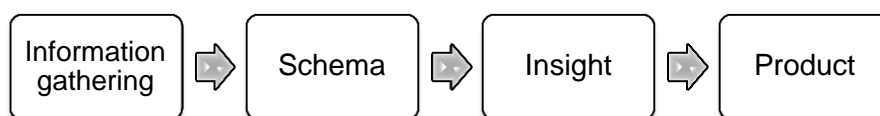

Figure 2-2: Simplified sensemaking process

### 2.1.1 The frame and the data frame theory of sensemaking

The data frame theory for sensemaking by Klein et al. (2006) have the same functional capability as the schema in the notional model (Pirolli & Card, 2005). The frame is the centre of the data frame theory. When people try to make sense of events they begin with a frame. A frame is a metaphor used by Klein et al. (2006) to describe a perspective or view point. It is internal to the perceiver (Pirolli & Card, 2005) and specific to what is being perceived (Klein et al., 2007; Russell et al., 1993). The metaphor “frame” can be expressed in many schematic ways: diagrams, stories, maps, hypothesis etc.

The data frame theory captures a number of sense making activities (Klein et al., 2006): frame elaboration, frame questioning, frame evaluation, reframing and the generation of a new frame. Klein et al. (2006) expresses a bi-directional street where the metaphor *frame*, both shapes data and is also shaped by the acquisition of data. The theory is a closed looped transition sequence between mental model formation (explanatory) and mental simulation (anticipatory) i.e. each loop is leading to either refining the existing frame or stimulating a new one. There are two parts to the theory of which each has their own dynamics and requirements. The elaborating and preserving the frame belongs to the left side of the model as can be seen in figure 2-3 and reframing belongs to the right side while questioning the frame belongs to the centre. In the centre, the user questions their frame leading them to either reframe or preserve their frame. While preserving their frame, this could lead to a further elaboration of the frame.

What is not evident in the data frame theory is the origination of the ‘frame’. Baber et al (2013) in a laboratory based study with the aim of exploring sensemaking through an intelligence analysis exercise suggested that the frame originates from a ‘draft frame’ which originates from the sorting of the artefacts (such as evidence data) provided for a case into categories such as events with dates, phone records, financial transactions etc. This allows

the participants to ask themselves some initial questions such as “what is individual Y doing at time X?” or “what were the outcomes of event Z?” (Baber et al., 2013, p. 131).

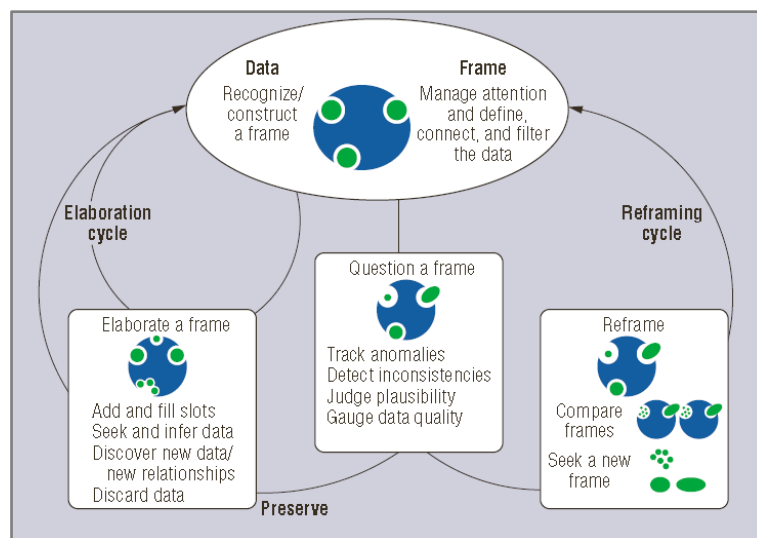

Figure 2-3: Data frame theory for sense making from Klein et al. (2006)

## 2.1.2 Representation

The schema (Pirolli & Card, 2005) may be casually in the analyst’s mind i.e. internal to the perceiver (Klein et al., 2007) or aided by a paper and pen or computer based system i.e. external to the perceiver. Whatever the case, representation is at the core of sensemaking (Russell et al., 1993; Atfield & Blandford, 2011; Bex, 2010) and it is sometimes easier to perform sense making externally, through the constructing of physical drawing (Kirsh, 2009) than internally. Kirsh (2009) describes an example that supports this argument. A user is provided this sentence to comprehend it “A basic property of right-angled triangles is that the length of a median extending from the right angle to the hypotenuse is itself one half the length of the hypotenuse” (Kirsh, 2009 p.1103). Take a few seconds to think about it. Kirsh (2009) asked another question, instead of representing why not just think? The answer to that question is given to us by Kirsh & Maglio (1994) who stated that through representation and interaction, it is sometimes less demanding to process more adequately, with better speed and accuracy than by working internally alone. If one reaches out for a pen and paper, it is much easier to comprehend the “*right-angled triangle*” sentence. The conclusion given to us by Kirsh (2009) indicates that it is easier to perform the sensemaking process externally through the construction of a physical drawing than it is to construct one in the “eyes of one’s mind” (Kirsh, 2009 p. 1104). More so, according to Bex (2010) one can only process a limited amount of information at one time. This is a general claim made by many psychologists (Ramsey, Jansma, Jager, Raalten, & Kahn, 2004; Klingberg, 2000).

## Chapter 2 Literature Review

Miller (1956) and Simon & Newell (1971) are probably the most famous. According to Simon & Newell (1971), the human is a “limited-memory information processor” (Simon & Newell, 1971, p. 155) and according to Miller (1956), humans are cognitively limited to retain seven plus or minus two ( $7 \pm 2$ ) items at a time.

Some people that have ‘good’ geometry knowledge may be able to easily understand the “*right-angled triangle*” sentence because sensemaking approaches vary among individuals as the complexity of a problem set also varies. Nevertheless, there is always a point where the cognitive load becomes too much and representation becomes vital.

Attfield & Blandford (2011) express that sensemaking operates as a two way street between data on one hand and representations that account for the data on the other which is linked to the thoughts of Klein et al. (2006). In an effort by Kirsh (2009) to inquiry why humans interact with the world when they try to *make sense* of things asked a question and it is quoted here “*Why do people create extra representations to help them make sense of situations, diagrams, illustrations, instructions and problems?*” The answer provided was that external representations do not only save internal memory and computation but also provide improved cognitive power. The next question that comes to mind is how? Kirsh (2009) highlight eight ways external representation enhance cognitive power. They are quoted here

*“they provide a structure that can serve as a shareable project of thoughts; they create persistent referents; they change the cost structure of inferential landscape; they facilitate re-representation; they are often a more natural representation of structure than mental representation; they facilitate the computation of more explicit encoding of information; they enable the construction of arbitrarily complex structure; and they lower the cost of controlling thought- they help coordinate thought”* (Kirsh, 2009 p.1103).

The powers of representations are grossly under emphasised (Russell et al., 1993). Representational forms “profoundly” affect effectiveness during problem solving. According to Russell et al. (1993) when one is faced with a problem involving large amount of information or a high complexity of a problem set, frequent solution is to improve the information retrieval process. A good example to support this is the case of the legal profession and electronic discovery (e-discovery). So much emphasis has been placed on improving search technologies. We talk about the continuous need to retrieve highly relevant documents. A problem Stuhldreher (2012) describes as the needle-in-the-haystack problem of finding relevant documents to a case when they are buried in tens of thousands of gigabytes of irrelevant documents. The most current technique to not only speed up information retrieval but increase recall and precision is predictive coding (Calloway, 2013) a

topic that is outside the focus of this thesis. However, Russell et al. (1993) states that whatever the task, speeding up the information retrieval process can do just little help as we still need to make sense of what is retrieved.

### 2.1.3 Re-representation

The core to the re-representation sensemaking process can be found in the work by Russell and colleagues called “*learning loop complex theory of sensemaking*” (see figure 2-4). It consists of three loops: generation loop, representational shift loop and data coverage loop. It starts with a search for a good representation (the generation loop) then an attempt is made to encode the representation with information (data coverage loop). Items that are task relevant but do not fit into the representation are called “residue”. This identification of the residue gives rise to the adjustment of the representation so that it has a better coverage of the information (representation shift loop). The end product is a more compact representation of the information relevant to the specific task.

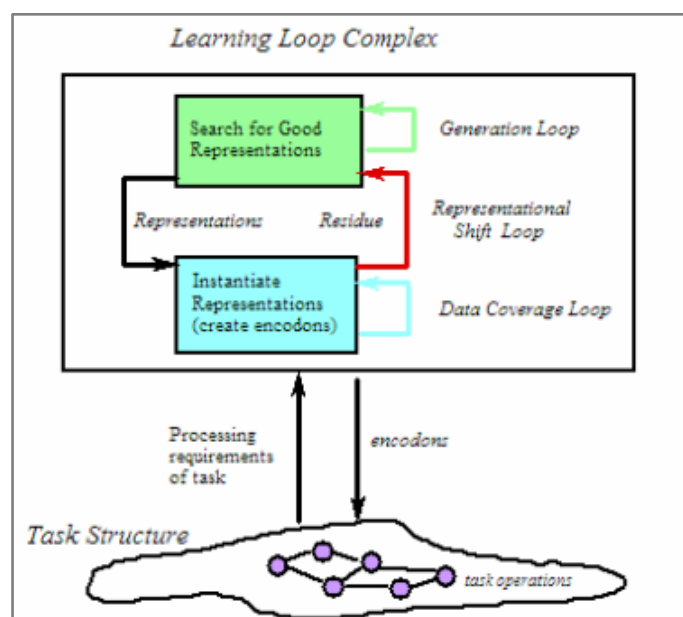

Figure 2-4: Learning loop complex theory of sensemaking

In conclusion of this section (section 2.1), we have discussed sensemaking and the notional sensemaking model and have gone in-depth into the ‘schema’ which enabled us to highlight the importance of external representation. External representing is important to sensemaking and we do not know which works in a sensemaking task. There are a number of candidates

that have been identified in literature. Bex (2010) draws our attention to two dominant approaches of representing: the argumentation approach and the narrative approach.

## 2.2 Argument structuring and mapping

*Arguments* are commonly used to develop and present cases (Cyra & Górski, 2011). They can be described as structures of claims in either an inferential or evidential relationship to each other (Sbarski, van Gelder, Marriott, Prager, & Bulka, 2008) in order to support and/or counter a claim (van Gelder, 2002). An *argument structure* is a presentation of an argument by graphical techniques (Sbarski et al., 2008). Le, Niebuhr, Drexler, & Pinkwart (2013) and van Gelder (2002) described a typical argument structure to be a “box and arrow” diagram where the nodes correspond to propositions and the links show their relations, be it evidential or inferential (Sbarski et al., 2008; van Gelder, 2009) or a structure made up of named circles and lines where each named circle represents a proposition and the lines represent inference (Macagno, Reed, & Walton, 2007). The graphical techniques used in the presentation of an argument structure are the use of graphs, tables or matrices and trees or trees (which can either be simple trees, hi-trees or bi-partite trees) (Sbarski et al., 2008).

It is an argued point that argument structuring improves critical thinking (Twardy, 2003; van Gelder, 2009) because one of the components of critical thinking is to produce arguments, comprehend their logical structure and examine their strength and weakness (Sbarski et al., 2008; Toulmin, Rieke, & Janik, 1979). However, it is not very popular. One of the reasons is because it is not practical for people to sketch out argument maps (Twardy, 2003).

Many authors such as van Gelder (2009), Twardy (2003) etc. consider argument mapping and structuring as the same thing. However, *Argument mapping or argument visualisation* is the activity of using argument maps (van Gelder, 2002) or the two dimensional (Twardy, 2003) diagramming of the argument structure (van Gelder, 2009; Reed, 2007). The rationale for mapping an argument is to uncover the structure of an argument in order to identify unstated assumptions or to evaluate the supports an argument provides to a conclusion (Fisher, 2004). According to van Gelder (2009) argument mapping is similar to other forms of mapping such as concept and mind mapping however, argument mapping is directed at the relationships among propositions be it evidential or inferential.

Argument mapping has been available since the early 20th century and the idea of it can be dated to as far back as Richard Whately in the 1850s (Macagno et al., 2007). However, it is

believed to have been originated by John Henry Wigmore (Goodwin & Fisher, 2000) or at least traced to Wigmore (Sbarski et al., 2008; Bex, 2010; van Gelder, 2009), who used argument mapping techniques to indicate legal case evidential structures (van Gelder, 2002; Rowe & Reed, 2006). Wigmore's work was wholly taken up from the view of formal logic (Macagno et al., 2007). Numerous papers have been written for the purpose of either interpreting (Chalamish, Gabbay, & Schild, 2011) or translating (Rowe & Reed, 2006) Wigmore's work. In the late 1950s Stephen Toulmin used mapping to show a general structure of informal argument theory (van Gelder, 2002). The Toulmin theory is the most generalised and has been used in a number of domains including educational critical teaching (Simon, Erduran, & Osborne, 2006). Toulmin is often said to have revolutionised argumentation (Macagno et al., 2007). Other people developed diagrammatic argument theories after Toulmin such as, Michael Scriven in the 70s, David Kelley in the 80s and James Freeman in the 90s (Macagno et al., 2007). Argument mapping or simply *argumentation theory* (van Gelder, 2009) specifies the entities to be represented and the relationships each entity have with the others and also provides a set of rules to govern structuring or mapping. Below we describe a number of them, providing examples to support their description.

### 2.2.1 Whately diagramming method

In *Whately diagramming method* (see figure 2-5), the user first figures out the argument's conclusion and then traces their thoughts backwards to find the reason the statement was made in the first place (Macagno et al., 2007). At the top of the diagramming method, Whately presents an "*Ultimate conclusion*" which is "*proved by*" two premises "*Y is X*" and "*Z is Y*". These premises individually are further "*proved by*" separate premises that appear below them and a continuation of other groups of premises. Whately's structure exhibits a lot of familiarity to the structures available today. That is, the statements e.g. "*Y is X, proved by*" represents the nodes and lines represents the propositions relations.

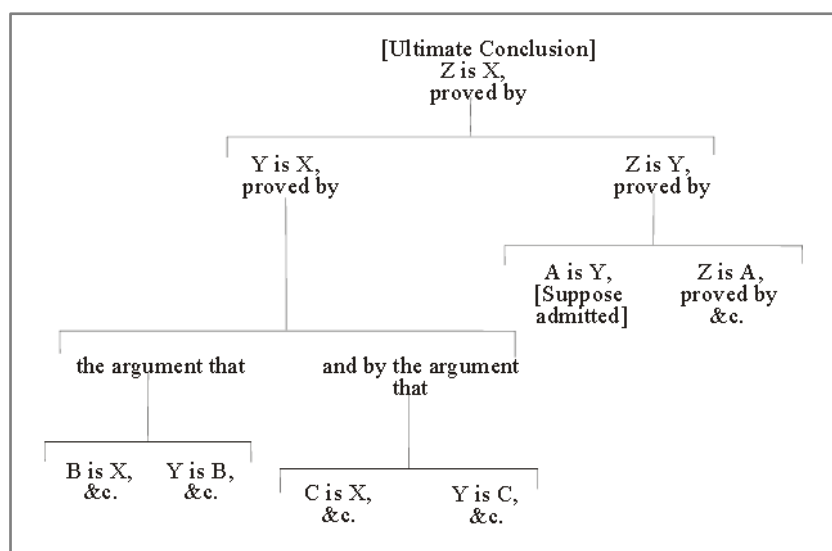

Figure 2-5: Whately diagramming from Macagno et al (2007, p.13)

## 2.2.2 Wigmore’s Chart

The motive behind Wigmore’s work was to define a visual language for reasoning with a large amount of evidence in a case at a trial (Bex, 2010). *Wigmore’s chart* method is a representational scheme with a number of conventions, two mainly: lines and shapes (Goodwin & Fisher, 2000). The *lines* represent the evidence processes (processes such as premise and conclusion, objection and conclusion, refute and conclusion etc.) and they connect the *shapes* which represents *facts*. The shapes are further numbered with each number corresponding to a statement collected in an “Evidence List” (Wigmore, 1913, p. 753).

Consider the example in figure 2-6, a sample of Wigmore’s chart (Wigmore, 1913, pp. 757–758) for the *Commonwealth v. Umilian* case concerning the alleged murder of J (Jedrusik) by U (Umilian). Table 2-1 shows the evidence list for the case and figure 2-7 shows the interpretation of the symbols and lines in the chart. The aim of the argument in figure 2-6 is to establish the conclusion “*Revengeful murderous emotion towards J*”. At first (the lines coming from below) Wigmore shows what injury Jedrusik caused to Umilian (evidence list 9). The next step (the line to the left) was to explain the impact of the injury over time (evidence list 18). Finally (lines going right), Wigmore provides more reason to support the argument (evidence list 20). The testimony of the witnesses (the square with a dot in the middle) provides evidential support in the chart (evidence list 18.1 and 20.1) “*A dot within the symbol of any kind of alleged fact signifies that we now believe it to be a fact.*” (Wigmore, 1913, p. 752).

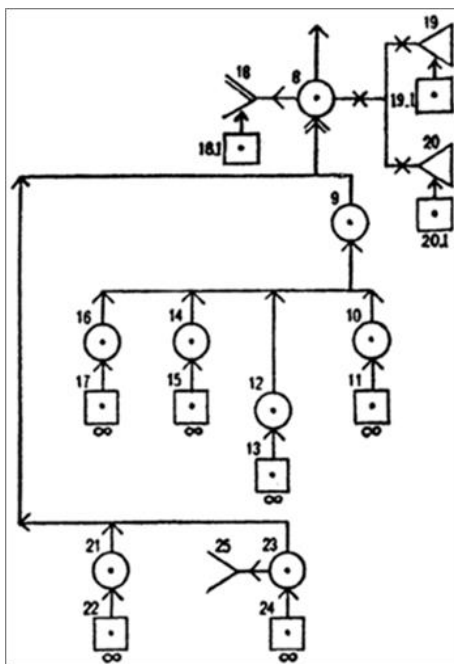

Figure 2-6: Part of Wigmore's Chart for Commonwealth v. Umilian from Goodwin and Fisher (2000 p.226)

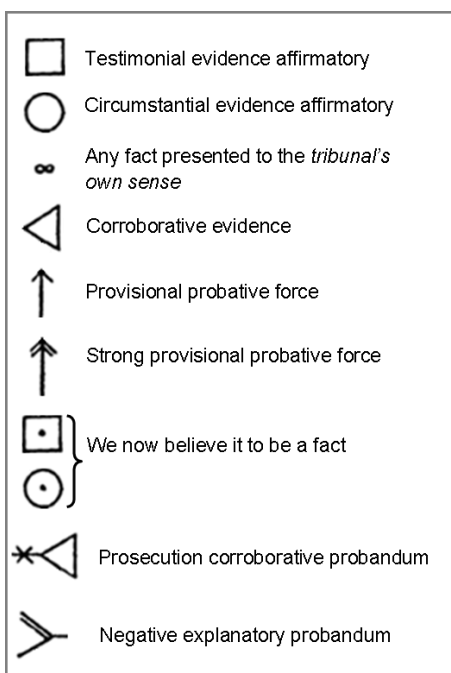

Figure 2-7: Wigmore's Chart symbols, lines and their interpretation from Wigmore (1913, pp. 751–753)



- 8** Revengeful murderous emotion towards J.
- 9** J. had charged him with intended bigamy Nov. 18., and had tried thereby to prevent his marriage.
- 10** Letter received by priest, stating that U. already had family in old country.
- 11** Anon, witnesses to this.
- 12** J. was author of letter, though it was in fictitious name.
- 13** Anon, witnesses to this.
- 14** Letter communicated by priest to U., with refusal to perform marriage; refusal later withdrawn.
- 15** Anon, witnesses to this.
- 16** Letter's statements were untrue.
- 17** Anon, witnesses to this.
- 18** U. being innocent, and marriage being finally performed, U. would not have had a strong feeling of revenge.
- 19** J. remaining in daily contact, wound must have rankled.
- 20** Wife remaining there, jealousy between U. and J. probably continued.
- 21** U. uttered threats and other hostile expressions between Nov. 18 and Dec. 31.
- 22** Anon, witnesses to this.
- 23** U., on Dec. 31, charged J. to K. with stealing K.'s goods.
- 24** Anon, witnesses to this.
- 25** Does not appear that these charges were false, hence not malicious.

Table 2-1: Evidence list for Commonwealth v. Umilian case from Wigmore (1913, pp. 757–758)

### 2.2.3 Toulmin diagramming method

The motive behind Toulmin's work was to provide a method where by formal logic could be used to explain and analyse everyday arguments (common arguments we hear and read daily) (Gass, 2009). *Toulmin diagramming method* provides us with a diagram that consists of six elements: claims, grounds, warrants, backing, modal qualification and possible rebuttals (see figure 2-8) (Toulmin et al., 1979).

The *claim* (C) is described as the 'destination' and the initiation of the argument. That is, the first stage of any argument is to establish ones stand or claim. The first set of question one is expected to ask is quoted here "*What exactly are you claiming? Where precisely do you stand on this issue? And what position are you asking us to agree to as the outcome of your argument?.*" (Toulmin et al., 1979 p.25).

After stating the *claim*, the next step is to consider the *grounds* (G) for the claim, that is, the 'underlying foundation' of the claim to decide if it is to be accepted as reliable or not. In this stage, one starts to ask questions such as "*What information are you going on? What grounds is your claim based on? Where must we ourselves begin if we are to see whether we can take the step you propose and so end by agreeing to your claim?* " (Toulmin et al., 1979 p.25). Various answers to this questions can surface such as; personal testimony, statistical data etc.

Next there is check to see if the step from claim to ground is "warranted" (W) that is, if the grounds truly provides adequate and appropriate support for the claim that has been stated and are not actually irrelevant to the argument. The questions considered at this stage are quoted here "*Given that starting point, how do you justify the move from these grounds to that claim? What road do you get from this starting point to that destination?.*" (Toulmin et al., 1979 p. 26). Just like the grounds, various answers can also surface such as rule of thumb, scientific formulas or laws etc.

Next there is a check to see what *backing* (B) the warrant has. That is, if the warrants themselves are trustworthy. The questions considered are quoted here, "*Is this really a safe move to make? Does this route take us to the required destination securely and reliably? And what other general information do you have to back up your trust in this particular warrant?.*" (Toulmin et al., 1979 p. 26).

The *modal qualifiers* (M) provide qualifications or degree of certainty to the warrant. Such as what is the frequency of their reliability i.e. usually, possibly etc. At this stage one asks questions such as "*Just how reliably does this warrant lend weight to the given step from grounds to claim? Does it absolutely guarantee this step? Does it support it with*

## Chapter 2 Literature Review

*qualifications? Or does it give us, at most, the basis for a more-or-less risky bet? ” (Toulmin et al., 1979 p. 26). The modal qualifiers tend to lead to various types of conclusions (probable, presumable, possible) as oppose to one of “certainties alone”.*

The *possible rebuttals (R)* report the stage or circumstance the arguments conclusion will be considered invalid. The final sets of questions to be asked are “*What kinds of factors or conditions could throw us off the road? What possibilities might upset this argument? And what assumptions are we implicitly relying on in trusting such a step*” (Toulmin et al., 1979 p. 26).

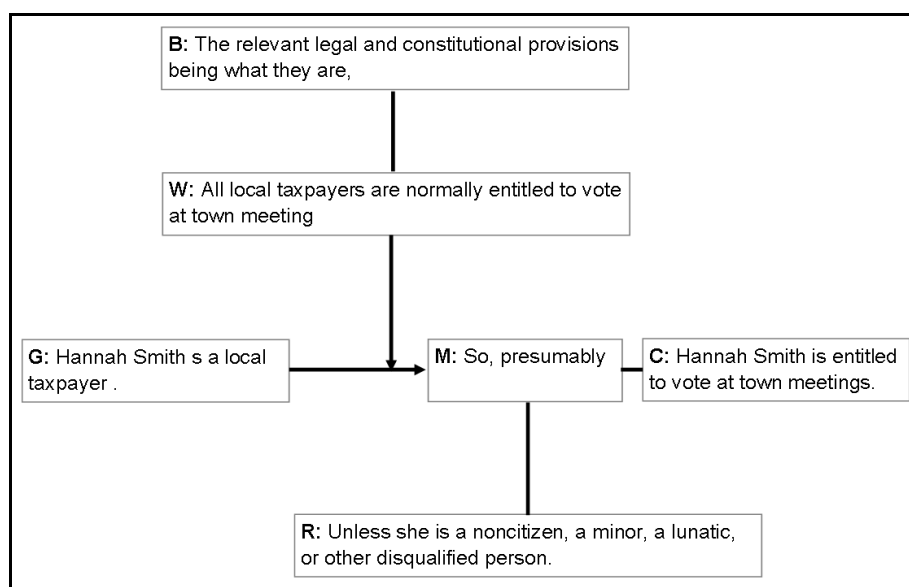

Figure 2-8: Example of an argument using Toulmin model (Toulmin et al., 1979 p.77)

Figure 2.8 shows an example of an argument structured using Toulmin model. It shows the claim (C) as “Hannah Smith is entitled to vote at town meetings”. The grounds (G) to that claim is “Hannah Smith is a local taxpayer”. “All local taxpayers are normally entitled to vote at town meetings” provides the warrant (W). “The relevant legal and constitutional provision being what they are,” provides backing (B) to the warrant. The argument has a modal qualifier (M) “So, presumably” and the rebuttals (R) is “Unless she is noncitizen, a minor, a lunatic, or other disqualified person”.

## 2.3 Narrative, its significance and construction

The other trend Bex (2010) mentioned was the narrative or story-centric (Hamilton & Chapin, 2012) approach. Narratives are one of the forms listed by Pirolli & Card (2005) for expressing a “frame”. The other forms stated were maps, diagrams etc. The inclusion of narrative to the forms that is used to express a frame according to Baber et al. (2013) simply implies the inference that what is actually necessary in sensemaking is a good narrative.

Bex (2010) refers to narrative as stories that tell what happened and what might happen in a case. According to Chatman (1980) story consists of chains of events (actions, happenings) and characters and settings. According to Bex (2010), Naugle (1999), Chapin, Attfield, & Okoro (2013) and Pennington & Hastie (1991), the narrative approach is the most natural approach of reasoning with evidence as oppose to the argument approach which in the words of Twardy (2003) “just isn’t practical” (Twardy, 2003 p.5). McElhaney (2009) emphasised that people only make their decisions via narratives and not by any other means,

*“People don’t make their decisions with syllogisms and rational progressions of principle. Stories—not rules—are what really influence our thinking. Since the dawn of time, we have used stories to teach, explain, understand how the world works, memorialize events and instill moral values”* (McElhaney, 2009, p. 2)

The significance of a narrative approach is massive. According to Naugle (1999) it penetrates the core of what it means to be human in the first place and according to Chapin et al. (2013), it is narrative that people of various cultures and from various generations have resorted to in order to make sense of the events of their lives. The benefits of the narrative approach are not fictitious or mere claims cognitive psychologists have provided empirical evidence to this (Pennington & Hastie, 1991). In an initial study by Pennington and Hastie (1991) with a goal to discover the cognitive process jurors take to decision making, a number of adult jurors from a jury pool were recruited. They showed the jurors a filmed stimulated murder trial of Commonwealth of Massachusetts v. Johnson (Hastie, Penrod, & Pennington, 1983; Pennington & Hastie, 1991). They proceeded to conduct and record a brief interview section with the experimental participants and analysed the protocols to understand how the jurors would internally organise the information. The first result of the analysis was that the jurors arranged information into a narrative structure even though they were not presented (shown) in that form. As much as “85% of all the events referred to in the protocols were causally linked” (Pennington & Hastie, 1991., p. 536). Indications of this came from the assertions the participants were making such as “Johnson was angry so he decided to kill

him” (Pennington & Hastie, 1991., p. 536). The second result of the analysis was that, interestingly, 55% of the protocol references were to events provided in the trial testimony and the other 45% were from “inferred events” from world knowledge about similar events and generic expectations about what makes a coherent (consistent, plausible and complete) story.

Pennington and Hastie went on to conduct a second empirical study to test what they had found earlier with the primary goal to test if jurors verdict decisions will be affected by the way trial evidence are presented to them in a case. They recruited a hundred and thirty college mock jurors to listen to a tape recording of the stimulated murder trial of Commonwealth of Massachusetts v. Johnson (with fifty prosecution and defence statement each summing a hundred- item version of the case) then the jurors were given a charge to choose between a guilty of murder verdict or not guilty verdict. The fifty prosecution statements and the first-degree murder story were presented either in story or witness order. The defence statements were also presented in either the story or witness order creating a four-cell factorial design. The result they found is shown in table 2.2. It indicated that those jurors who heard the prosecution evidence in the story order and defence in the witness order (non-story order), 78% decided to convict (chose guilty) and when the defence evidence was presented in story order and the prosecution in witness order, only 31% decided to convict. They made two conclusions. Firstly, the manner trial evidence are presented to jurors affect their decisions and also it was easier to understand evidence when they are presented as a coherent narrative.

<b>Prosecution evidence</b>	<b>Defence evidence</b>		<b>Means</b>
	<b>Story order</b>	<b>Witness order</b>	
<b>Story order</b>	59%	78%	69%
<b>Witness order</b>	31%	63%	47%
<b>Means</b>	45%	70%	

Table 2-2: Percentage of Subjects Choosing a Verdict of Guilty of Murder by Prosecution and Defence Order Conditions from Pennington and Hastie (1991).

This study and many other studies by Pennington and Hastie have provided the rationale for what they call the ‘Story Model’. According to the Story Model, people resort to narrative construction of organising trial evidence in order to explain the evidence and make sense of them (Hastie et al., 1983; Pennington & Hastie, 1986, 1992, 1991).

## 2.4 Hybrid approach

It was not long before Bex (2010) saw the significance of both the argumentation and narrative approaches during sensemaking. Bex (2009) created a *hybrid theory* that combines the two approaches: argumentation and narrative. In the hybrid approach, the narrative about what occurred in a case is constructed then arguments which are based on evidence or “common sense” are used to provide support for or counter against the narrative (Bex, van Koppen, Prakken, & Verheij, 2010; Bex, 2009). The benefit of the hybrid approach surpasses the benefits of the two approaches individually. The main benefit of the hybrid approach is that, it lessens “tunnel vision” (Bex, 2010). This Heuer (1999) describes as a situation where the most obvious narrative is taken as the main hypothesis and other narratives are overlooked. Also it provides argumentative support for a story. The hybrid theory has been developed into a sensemaking and visualisation tool called AVERs (argument visualization tool for representing stories about evidence) (van den Braak, Vreeswijk, & Prakken, 2007). AVERs allows two main things, the first, visualisation of a narrative as well as its argumentative support and also, it allows a user to directly link arguments to the evidence used in those arguments (Bex, 2010).

Figure 2.9 shows a redrawn example from Bex (2010). Here, Rijbloem is accused of killing his girlfriend father Nicole (Davies, Lloyd-Bostock, McMurrin, & Wilson, 1996 p.283). His defence was that Nicole’s mother had accidentally shot him. The green rectangles represent the narrative and the blue and red rectangles represent case evidence (witness’s testimony and police report) either providing argumentative support for or counter against the narratives.

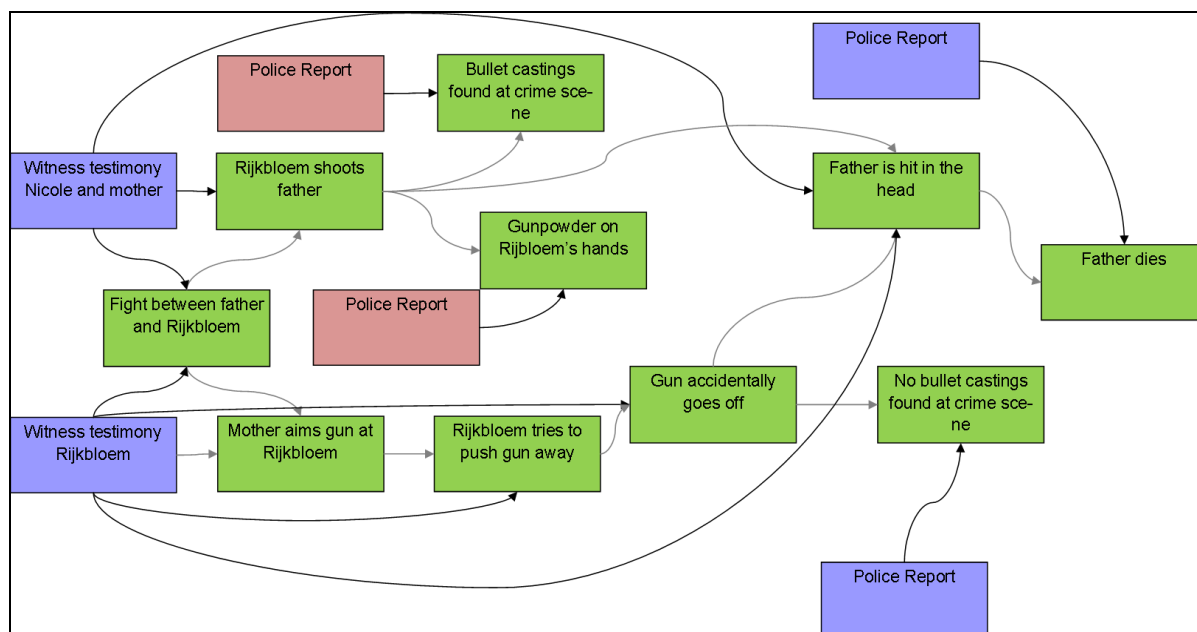

Figure 2-9: Combining narrative and argument, the hybrid model from Bex (2010 p.2)

## 2.5 Conclusion

In conclusion of this chapter, we have observed that sensemaking can be helpfully supported by external representations in investigations. Two dominate external representation types were identified: narrative embedded in timeline and argumentation. Twardy (2003) and van Gelder (2009) claim that argument improves critical thinking however according to the results from Pennington & Hastie (1986, 1991, 1992) study , narrative is the most natural way of representing in sensemaking. This raises the question of which representation is best.

# Chapter 3

## Study Method



# Study Method

## 3.1 Overview

The aim of this thesis is to explore the impact that different types of external representational structuring might have on performance and user experience during intelligence type investigations. We have hypothesised that given the role that timeline representation play given evidence that people are natural predisposed to make sense of complex social scenarios by constructing exploratory narratives. If people are then given a timeline representation, they will exhibit better performance and user experience than the other representation we identified from literature, argumentation representation. We also have included a freeform representation in other to see what people would naturally do in sensemaking task like this. If the hypothesis is right, then it should be quantifiable.

In order to test the hypothesis, a study was set up with representational convention (with three levels; argumentation, timeline and freeform) as the independent variable and performance and user experience as the dependent variables.

Since a part of exploratory investigation is document review (Chapin et al., 2013), given a 'ground truth' dataset with a knowledge of the relevant documents it contains, standard information retrieval (IR) measures such as *recall* and *precision* (Brassil, Hogan, & Attfield, 2009; Teufel, 2006; Rijsbergen, 1981; Blanco & Silvestri, 2008), can be used as a metric for effectiveness. Effectiveness is a variable used to evaluate information retrieval performance (Rijsbergen, 1981). It deals with the retrieving of the most relevant information to a user's need (Blanco & Silvestri, 2008). Duration of time spent to complete the task can be used to measure efficiency. Efficiency is another variable used to evaluate information retrieval performance (Blanco & Silvestri, 2008). It deals with the speed at which information is provided to a user (Blanco & Silvestri, 2008). The participants understanding of key facts of the dataset can also be measured by asking questions about the dataset.

These performance measures can be mixed up with user experience measures such as the measure of psychological engagement which can be measured through a standardised questionnaire developed by O'Brien (2010) from the research on facilitating user engagement in the design of interactive systems (O'Brien & Toms, 2010). The cognitive load the task impose on the participants can also be measured using a ratio of duration judgement (Block & Zakay, 1997). Also, the confidence they ascertain to their individual responses to the questions on understanding can be measured using a standardised format

of the intelligence confidence levels scale developed by the United States Joint Chiefs of Staff committee (2007).

In this study, in order to determine the impact that different types of external representational structuring have on performance and user experience during intelligence type investigations, a number of measures were identified. The user experience measures were; cognitive load, engagement and confidence while the performance measures were: recall, precision, efficiency and understanding. Participants are asked to perform a small investigation with a 'ground truth' collection in which they search, review and organise selected information into representational conventions that are either argumentational or chronological or in freeform (which is not constrained to any representational convention).

## 3.2 Design

This study used an independent measure design. There was one independent variable: representation conventions (with three levels; timeline, argumentation or freeform). Participants were asked to search, review and organise selected information into representational conventions that are either argumentational, chronological or in freeform (which is not constrained to any representational convention). The experiment used a wholly between-group design, with each participant assigned to only one of the representation conventions. The dependent variable was a set of performance and user experience variables. The performance measures were: recall, precision, efficiency and understanding while the user experience measures were: cognitive load, engagement and confidence in participants understanding.

### 3.2.1 Recall:

Recall is measured as the proportion of the total number of relevant documents identified among the total number of relevant documents in the document population (Teufel, 2006). At the end of the task, the documents the participants used for their representation were collected and then the recall values were calculated using equation 3-1.

$$Recall = \frac{\textit{Total number of relevant documents identified}}{\textit{Total number of relevant documents in the document population}}$$

Equation 3-1: Formula for measuring participant's recall

### 3.2.2 Precision:

Precision is measured as the proportion of the total number of relevant documents identified among the total number of retrieved documents (Teufel, 2006). At the end of the task, the documents the participants used for their representation were collected and then the precision values were calculated using equation 3-2.

$$Precision = \frac{\text{Total number of relevant documents identified}}{\text{Total number of retrieved documents}}$$

Equation 3-2: Formula for measuring participant's precision

### 3.2.3 Task duration:

This is the time it takes the participant to complete the task.

### 3.2.4 Cognitive load:

Cognitive load (Block, Hancock, & Zakay, 2010) or mental workload (Hertzum & Holmegaard, 2013) is the amount of information processing (especially attention or working memory) demanded during a specific time duration i.e. the amount of mental effort demanded by a task (Block et al. 2010).

Duration judgement or estimation is a reliable and valid measure of cognitive load (Block et al. 2010). However, it depends on two paradigm: prospective and retrospective (Block et al., 2010; Sucala, Scheckner, & David, 2011). At the beginning of a given task, in the *prospective paradigm estimation*, the participant is informed that they will be making a subjective duration estimation while in the *retrospective paradigm estimation*, the participant is not informed until the end of the given task. The outcome of the paradigm choice also differs. The higher the cognitive load, the lower the prospective duration judgement and the higher the retrospective duration judgment respectively (Block et al., 2010; Sucala et al., 2011) (see figure 3-1).

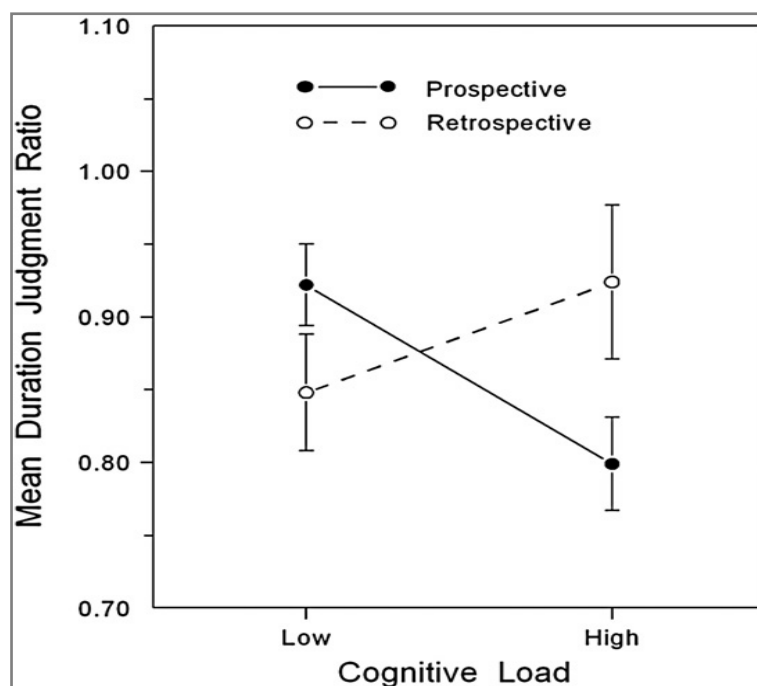

Figure 3-1: Mean duration judgment ratio in the prospective and retrospective paradigms as a function of cognitive load. Error bars are the standard errors of the mean from (Block et al. 2010)

Duration judgement is measured as the ratio of subjective duration estimate (or interval duration estimate (Sucala et al., 2011) ) to objective duration (Block et al. 2010) (see equation 3-3). Subjective duration is defined as the subjective evaluation of duration (Sucala et al. 2011) and objective duration is the objective evaluation of duration. In other to asses this, a person is asked to verbally estimate the duration of an activity or task (Sucala et al. 2011). For the study, participants were asked to make a retrospective subjective estimate i.e. they were not informed they will be making a subjective duration estimate till the task was completed. For the duration judgement involving the retrospective paradigm, a value greater than one represents a temporal overestimate which indicates higher cognitive load and a value lower than one represents a temporal underestimate which indicates lower cognitive load (Sucala et al., 2011).

$$Duration\ judgement = \frac{Subjective\ duration}{Objective\ duration}$$

Equation 3-3: Formula for calculating duration judgement

### 3.2.5 Understanding:

Understanding is measured by assigning scores to participant's verbal responses to questions about key facts of the task. The questions include: What is the potential terrorist threat, who is involved in the potential terrorist threat, when is the terrorist attack likely to happen, where is the terrorist attack likely to take place and how was the terrorist threat likely to happen (see appendix A). Scores of 1 and 0 were given. 0 was given when a participant got an answer wrong and 1 was given when they got it right.

### 3.2.6 Confidence:

The confidence users place on an answer is measured using a confidence level scale provided by the United States Joint Intelligence Committee intelligence (2007). After a participant respond to a question for example "*what is the potential terrorist threat*", they are presented a confidence level scale to indicate how confident they are of the answer they have provided. The scale contains levels such as; highly probable (>90%), probable (60-90%), chances are slightly greater (or less) than even (40-60%), probably not (10-40%) and highly improbable (<10%) (See appendix A).

### 3.2.7 Engagement:

In order to understand the factors that compose engagement and be able to evaluate them to facilitate engaging user experience in the design of interactive systems, O'Brien & Tom (2010) identified six attributes of engagement and developed a user engagement questionnaire from them (O'Brien, 2010). An adaptation of the user engagement questionnaire by O'Brien & Toms (2010) is used to assess engagement in this study. It included sections on Felt Involvement (FI), Focused Attention (FA), Endurability (E) and Perceived Usability (PUs) (See appendix A).

## 3.3 Participants

There were 30 participants (9, 11, 10 participants for the argumentation, freeform and timeline conditions respectively), they were all postgraduate students. The rationale for choosing 30 participants was because of the central limit theorem that states that using 30 participants in an experiment increases the likelihood of obtaining a normal distribution during analysis (Bruin, 2011). All participants voluntarily accepted to take part in the study. They were allocated to various groups randomly. Participants who were recruited were approached and asked to take part in the study. 14 were female and 16 male with an age range of 20 to 45 (mean = 28 years, standard deviation = 6.4 years) (see figure 3-2). 18 were native English speakers and 12 were not (see figure 3-3).

Participants took part in the study without the knowledge of the aims and purpose of the study.

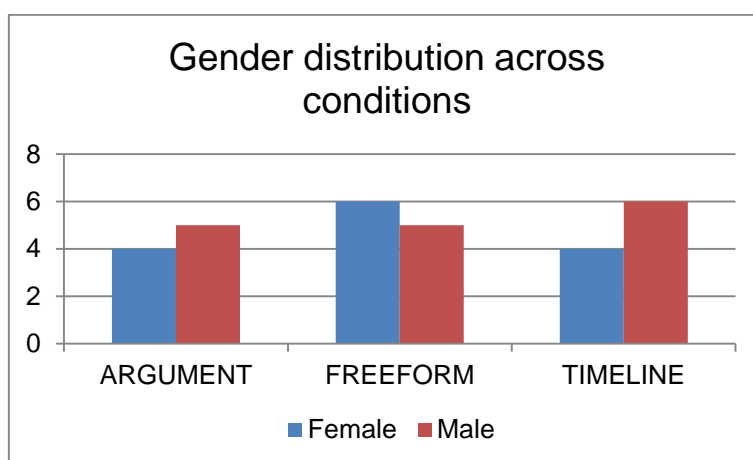

Figure 3-2: Gender distribution across conditions

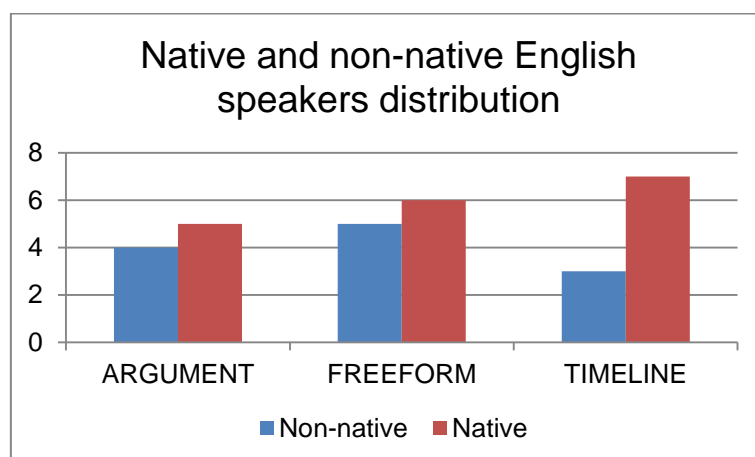

Figure 3-3: Native and non-native English speakers distribution across conditions

### 3.4 Materials

A handpicked subset of the IEEE VAST mini challenge 3 dataset was used as the problem set for the task. The data was a corpus of news reports about a fictional town called Vastopolis. A PC running Microsoft OneNote and Windows search explorer was used for the investigative task. Microsoft OneNote was used as the platform for the representation because OneNote allows users to combine and arrange documents, text snippets and add annotations on a single visual canvas. Windows search explorer was the tool for keyword searching through the dataset. Screen capturing software was used to capture the task for later analysis and also record the duration of the task. An audio recorder was used to record the question and answer dialogue in order to assess the participants understanding (see appendix A for the questions asked). A degree of confidence questionnaire was used to measure subjective confidence in the answers provided (See appendix A). An adaptation of the user engagement questionnaire by O'Brien (2010) was used to measure subjective engagement (see appendix A). The adaptation of the user engagement scale included sections on Felt Involvement (FI), Focused Attention (FA), Endurability (E) and Perceived Usability (Pus). These sections were selected among six other sections that included: Aesthetics and Novelty. The Aesthetics and Novelty sections of the questionnaire were not included because they were not applicable to quantification we are trying to make.

## 3.5 Procedure

Participants initially completed an informal consent form (see appendix A). The procedure followed a general training (a training section all participants went through).

### 3.5.1 Training

Participants were given general and condition-specific training. Participants were given general training to allow them to be familiar with Microsoft OneNote and the search tool, Microsoft Windows Explorer. Participants in the argumentation and timeline conditions were then given brief PowerPoint presentations on how to represent their investigations in those forms (see appendix B).

The argumentation structure adopted is a simplified hybrid of argument models by Toulmin (1979) and Wigmore (1913). Participants were shown how to create a three-level argumentation structure consisting of: *conclusion*; *intermediate propositions* which can either support or counter the conclusion, and *evidence* which supports the intermediate propositions. Blue and red lines are used to indicate supporting and countering sub-arguments respectively (see figure 3.4).

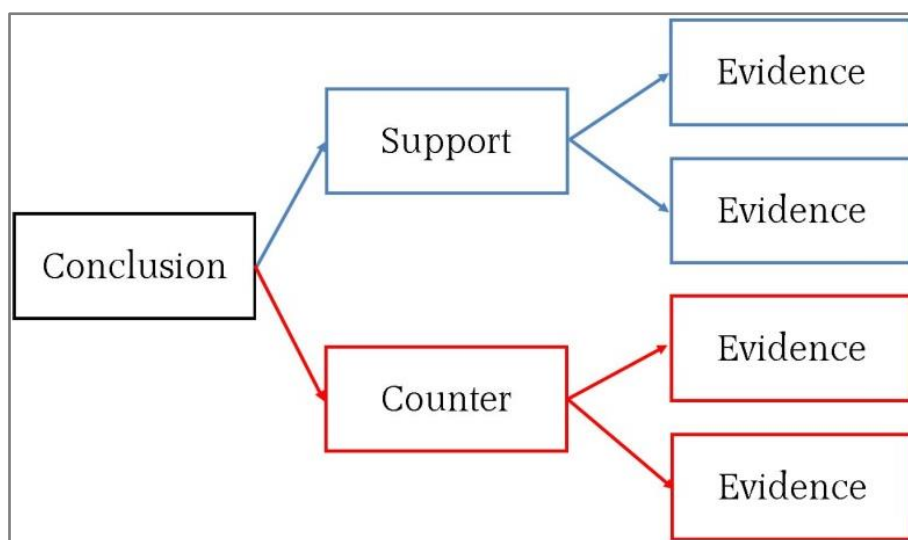

Figure 3-4: Argument structure used by the participants for the argument condition

In the timeline condition participants were instructed to create a timeline using the relevant documents found. Then to keep iterating the process until they have gotten all their answers.



Participants in the freeform condition were told to conduct the investigation in whatever way that suited them and were told to use the representation platform for any representation they needed to do.

## 3.5.2 Task

The task was to identify any terrorist threat in a fictional place, Vastopolis.

### 3.5.2.1 Problem set

The problem set uses data and questions from the IEEE 2011 VAST challenge (IEEE VAST, 2011b). Given a corpus of news reports about a fictional town called Vastopolis, participants are asked to: (1) identify any imminent terrorist threats in the Vastopolis metropolitan area; (2) provide detailed information on the threats (e.g. who, what, where, when, and how); (3) provide a list of the evidential documents supporting their answer (IEEE VAST, 2011a).

The VAST dataset contains over 4000 plain text documents, manually generated or modified from an existing corpus of news reports. Each report is a plain text file containing a headline, date of publication, and the content. For the current study we selected a subset of 30 articles. These were not selected at random but was handpicked to include 13 documents that were relevant to the threat (determined by the VAST challenge committee), and an additional 17 irrelevant documents selected to add noise (see table 3-1).

<b>Document type</b>	<b>Document serial numbers</b>	<b>Total</b>
<b>Related to imminent threat (relevant)</b>	03212, 03740, 03040, 03662, 04085, 04080, 01785, 03435, 01878, 01030, 01038, 03295, 02385	13
<b>Related to isolated case (irrelevant)</b>	03375, 04156, 01482, 01594, 02696, 00432, 04314, 00008, 03563, 01750, 02900, 01243, 00274, 03772, 03874, 02664, 03237	17
		30

Table 3-1: The document serial numbers for the relevant and irrelevant documents used in the study

### 3.5.3 Data collection

The investigation processes were recorded using screen recording software for later analysis. Participants were not encouraged to 'think aloud' since this would disrupt the duration of time spent measurement of the task. However, after the task a question and answer session is conducted which assess the participants subjective perception of time and ask a series of factual questions and probe for confidence ratings. Following the interview, participants are asked to complete the user-engagement questionnaire.

### 3.5.4 Debrief

Participants were thanked and urged not to discuss the study with any of the other postgraduate students selected to take part in the study.

# Chapter 4

## Study Findings

## Study Findings

This section shows the findings of the study to explore the impact that different types of external representational structuring have on performance and user experience during intelligence type investigations. As stated in the method section, we are measuring this impact based on a number of performance and user experience measures: recall, precision, duration, cognitive load, confidence, understanding and engagement.

After the study was completed, a test for normality was conducted on the data acquired from the study. This was done using a well-known approach where the density distribution of the sample data (this was done using the `density()` function in R (Zhao, 2012)) is compared to a normal probability curve (D'Agostino & Stephens, 1986). The result of the density distributions indicated that the data acquired were not normalised (see appendix C). Figures 4-1, 4-2 and 4-3 show samples of the non-normalised distributions. The other distributions can be found in appendix C.

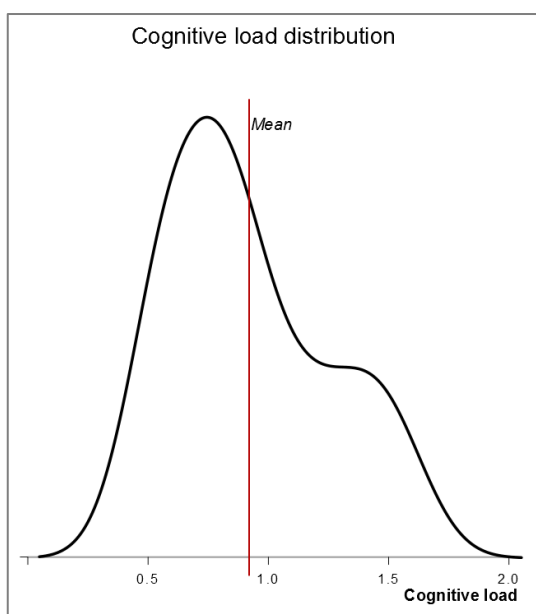

Figure 4-1: Cognitive load Distribution and mean

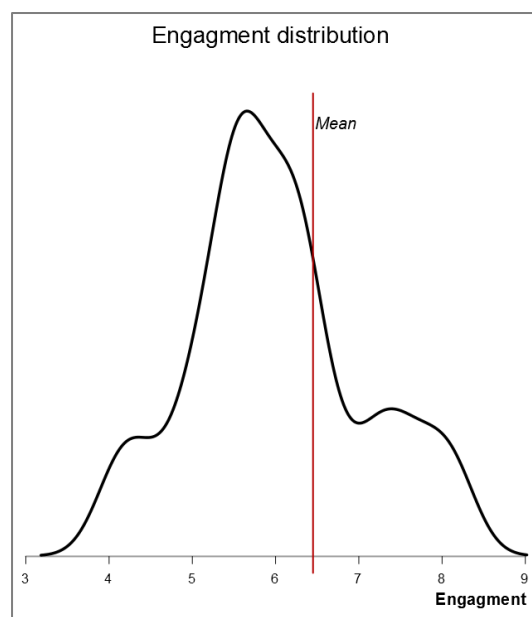

Figure 4-2: Engagement Distribution and mean

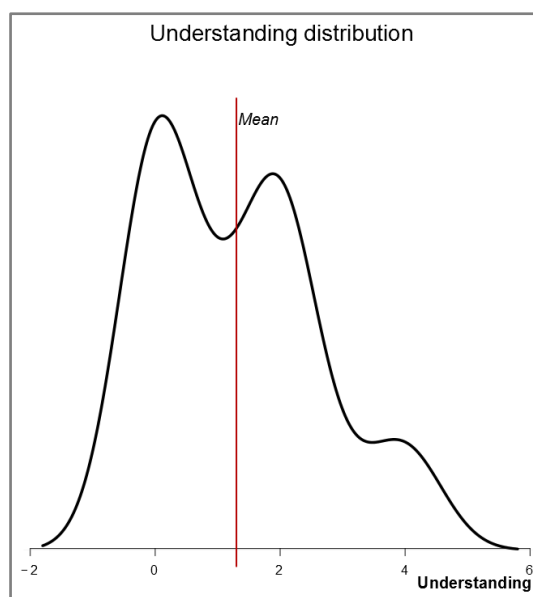

Figure 4-3: Understanding Distribution and mean

A non-parametric Kruskal–Wallis one way analysis of variance test was performed to test for significance. The reason for the non-parametric test choice as oppose to a parametric alternative ANOVA was because, (1) parametric tests have some assumptions on normality of distribution and homogeneity of variance. However as can be seen in the figures above (Figures 4.1; 4.2; 4.3) showing samples of the distribution of dependent variables, the data gathered during the study did not realise the conditions for a parametric test to be conducted i.e. the distributions when plotted were not normally distributed. (2) An advantage of using a non-parametric test is that it is usually used when the examined groups are of unequal size (different number of participants) (Dancey & Reidy, 2011) which is similar to the case we have here i.e. argumentation, freeform and timeline conditions have nine (9), eleven (11) and ten (10) participants respectively. The Kruskal-Wallis test is reported with three elements  $H$  indicating the chi square,  $df$ . indicating the degree of freedom and  $p$  indicating the test for significance (McDonald, 2009). For example ( $H=6.894$ ,  $df = 2$ ,  $p<0.05$ ).

The significance level used was 0.05. The effect size is not calculated using the Kruskal Wallis test because there is no straight forward way to calculate the effect size for the Kruskal Wallis  $H$  test. However, one can calculate the effect size with the Mann-Whitney  $U$  test (Koji, 2013).

The effect size is used to assess the importance of an experimental effect regardless of the significance of the test statistics (Field & Hole, 2003). It is a standardised method of quantifying the size of the difference between various groups (Field & Hole, 2003).

## Chapter 4 Study findings

According to Harris (2008) it helps us to answer the question of “how big”. That is, how big an effect does the independent variable (IV) create on the dependent variable (DV).

The Pearson's  $r$  correlation coefficient is commonly used to calculate effect size (Field & Hole, 2003). The value is constrained to lie between 0 and 1 where 0 indicates no effect and 1 indicates a perfect effect. It has an objective and standardised scale which is used for its interpretation (Koji, 2013 ;Field & Hole, 2003). The scale is provided in Table 4-1.

	<b>Small size</b>	<b>Medium size</b>	<b>Large size</b>
<b><math>r</math></b>	0.1	0.3	0.5

Table 4-1: The standard values for effect size from Koji (2013)

Equation 4-1 shows the formula for the Mann-Whitney U test effect size provided by (Koji, 2013). Where  $N$  is the total number of the samples and  $Z$  is the z-score. The z-score is provided when a Mann-Whitney test is conducted.

$$r = \frac{Z}{\sqrt{N}}$$

Equation 4-1: The effect size formula for a Mann-Whitney test from Koji (2013)

## 4.1 Test of significances and effect size

This section shows the test of significances for all variables observed i.e. duration, recall, precision, understanding, confidence, engagement and cognitive load. It also contains an effect size calculation for the significant measures observed.

### 4.1.1 Duration

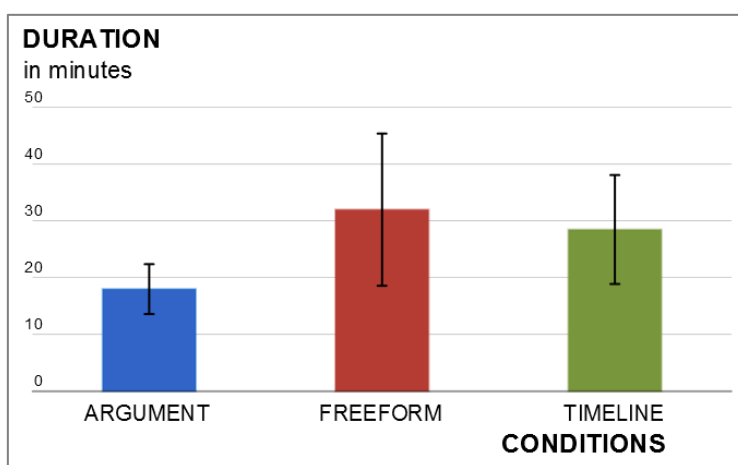

Figure 4-4: Bar graph showing median duration in minutes with error bars indicating the median absolute deviation

Duration is measured as the time taken for a participant to complete the task. Figure 4-4 shows that participants in the freeform condition spent more time (median,  $M= 32$  minutes) completing their task than the timeline participants ( $M=28.5$  minutes) who spent more time than the argumentation participants ( $M=18$  minutes). However, the Kruskal–Wallis test reported no significant differences between the conditions ( $H=1.098$ ,  $df.=2$ ,  $p>0.05$ ).

## 4.1.2 Precision and Recall Comparison

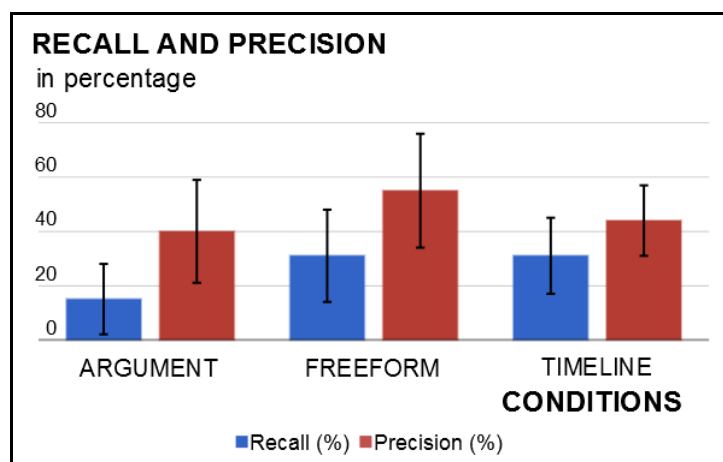

Figure 4-5: Bar graph showing median percentage recall and precision values with error bars indicating their median absolute deviation

As stated in the method section, recall and precision are standard measures for information retrieval. Precision is the fraction of documents participants identify as relevant and are actually relevant while recall is the fraction of documents that are actually relevant that the participants recognises as such (IBM Corporation, 2007). Figure 4-5 shows that the participants in the freeform condition had better performance in terms of recall ( $M=31\%$ ) and precision ( $M=55\%$ ) than the participants in the timeline condition (recall median = 31%, precision median= 44%) who performed better than the participants in the argumentation condition (recall median = 15%, precision median= 40%). However the Kruskal–Wallis test reported no significant differences between the conditions for recall ( $H=2.149$ ,  $df.=2$ ,  $p>0.05$ ) and precision ( $H=1.281$ ,  $d.f.=2$ ,  $p>0.05$ ).

### 4.1.2.1 F measure analysis

Precision and recall were not significant but the F measure value can be suggestive. The combination of recall and precision is called the *F score* or *F measure value*. The F measure is the harmonic mean or weighted average of precision and recall. It measures the effectiveness of retrieval with respect to both precision and recall (Rijsbergenr, 1979). It is constrained between the values of zero (0) and one (1) where a value of 1 indicates the best possible value meaning best information retrieval performance and a value of 0 the lowest possible value indicating worst information retrieval performance. Equation 4-2 shows the formula for F measure.



$$F\ measure = 2 * \frac{Precision * Recall}{Precision + Recall}$$

Equation 4-2: The formula to calculate F measure

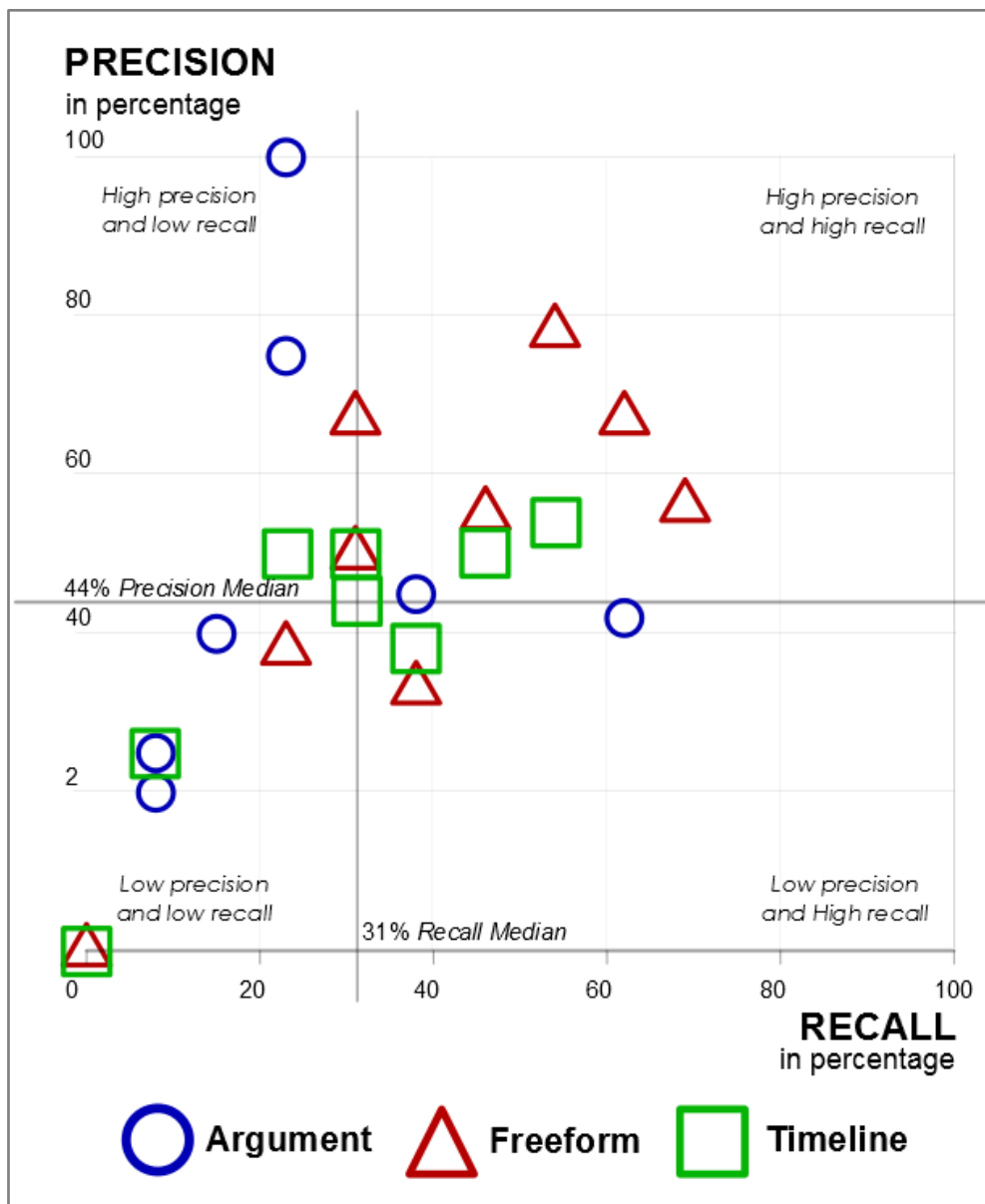

Figure 4-6: Scatterplot showing the F measure values for all participants per condition

## Chapter 4 Study findings

Figure 4-6 provides an instant visual sense of the participant's information retrieval performance (IBM Corporation, 2007). The median precision and recall values are used to divide the scatterplot into four quadrants. The upper left, upper right, bottom left and bottom right quadrants represents high precision and low recall, high precision and high recall, low precision and low recall, and low precision and high recall respectively. Participants with *high information retrieval performance* are placed in the upper right quadrant of the graph while participants placed in the lower left quadrant of the graph have *low information retrieval performance* (IBM Corporation, 2007). Figure 4-6 shows that 4 out of 11 (36%), 2 out of 10 (20%) and 1 out of 9 (11%) of the freeform, timeline and argumentation participants respectively are positioned in the high precision and recall quadrant of the graph while 5 out of 9 (56%), 3 out of 11 (27%) and 2 out of 10 (20%) of the argumentation, freeform and timeline participants respectively are positioned in the low precision and recall quadrant of the graph. This shows that the freeform condition had a better performance in terms of recall and precision combined than timeline which is better than argumentation (see table 4-2). However the Kruskal–Wallis test reported no significant differences between the conditions for F measure ( $H=2.583$ ,  $d.f.=2$ ,  $p>0.05$ ).

Condition	High performance (%) (High Recall and Precision)	Low performance (%) (Low Recall and Precision)
Argument	11.1	55.6
Freeform	36.4	27.3
Timeline	20.0	20.0

Table 4-2: The percentage of high and low performing participants per condition

### 4.1.3 Understanding

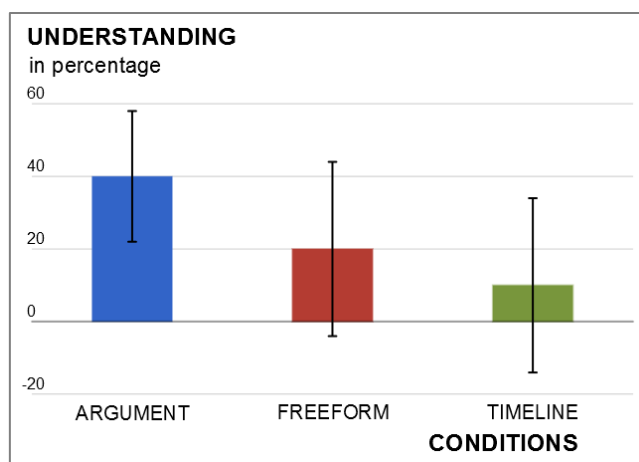

Figure 4-7: Bar graph showing median understanding with error bars indicating the median absolute deviation

Understanding is measured by assigning scores to participant's verbal responses to five questions about key facts of the task. Scores of 1 and 0 were given, 0 was given when participants got an answer wrong and 1 was given when they got it right. Figure 4.7 shows that the argumentation condition ( $M=40\%$ ) had a better understanding value than the freeform ( $M=20\%$ ) which is better than the timeline ( $M=10\%$ ) condition. However, the Kruskal–Wallis test reported no significant differences between the conditions ( $H= 0.187$ ,  $df.=2$ ,  $p>0.05$ ).

### 4.1.4 Confidence

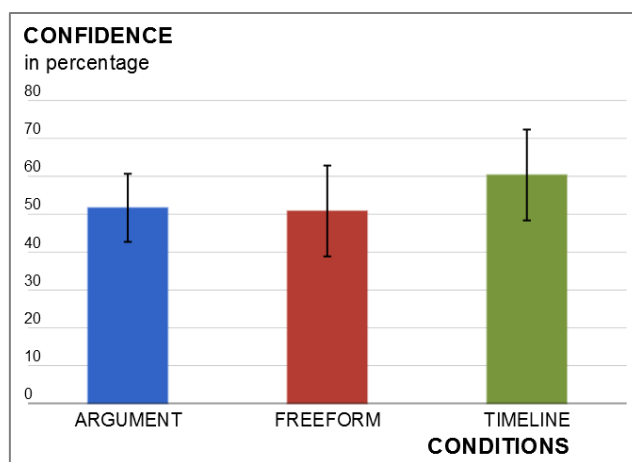

Figure 4-8: Bar graph showing median confidence with error bars indicating the median absolute deviation

When a participant provides an answer to a question, they are presented a confidence level scale to indicate how confident they are of the answer they have provided from >90% indicating highly probable to <10% indicating highly improbable. Figure 4-8 shows that the participants in the timeline condition ( $M=58\%$ ) had better confidence on their answers than those in the freeform condition ( $M=50\%$ ) which is better than those in the argumentation ( $M=47\%$ ) conditions. However, the Kruskal–Wallis test also reported no significant differences between conditions ( $H= 0.59, df= 2, p>0.05$ ).

### 4.1.5 Cognitive load

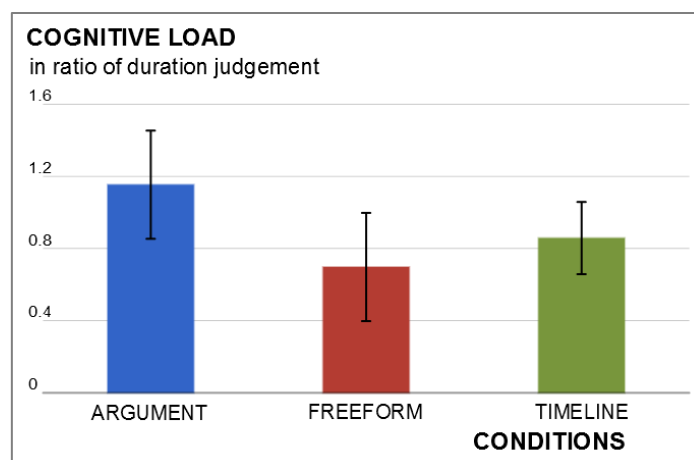

Figure 4-9 Bar graph showing median cognitive load with error bars indicating the median absolute deviation

Cognitive load is measured as the ratio of the participant's subjective perception of time (estimated time to complete the task) against the actual time taken to complete the task. A value greater than 1 represents a temporal overestimate which represents higher cognitive load and a value less than 1 represents a temporal underestimate which represents lower cognitive load. Figure 4.9 indicates that the freeform and timeline conditions exhibited an underestimate value for ratio of duration judgement however, the freeform condition exhibited a much lower cognitive load ( $M=0.7$ ) than the timeline condition ( $M=0.9$ ). Also, the argument condition exhibited an overestimate ( $M=1.2$ ) indicating a much higher cognitive load than timeline which is higher than freeform. The Kruskal–Wallis test reported a significant main effect of cognitive load ( $H= 6.894, df. =2, p<0.05$ ).

A Mann-Whitney U test was conducted on the cognitive load variable because a Kruskal–Wallis test tells only whether one has an overall difference (significant variation) between their conditions, but it does not tell which specific groups differ. It is reported with three elements; the U value, Z value and the p value (Walker, 2008).

The two tailed Mann-Whitney test conducted indicated that there is a significant difference between the argumentation and freeform condition ( $U=18, Z=0.875, p<0.05$ ). The value for the effect size is  $r =0.54$ . Using the benchmark for the effect sizes shown in table 4-1, there is a larger effect (it is greater than .5). Therefore the effect of argumentation and freeform representational structuring on cognitive load is a substantial finding.

## Chapter 4 Study findings

The other two tailed Mann-Whitney test conducted indicated no significant difference between the freedom and timeline conditions ( $U=41$ ,  $Z=0.986$ ,  $p>0.05$ ).

The one tailed Mann-Whitney test conducted indicated that there is a significant difference between the argumentation and timeline conditions ( $U=21.5$ ,  $Z=1.924$ ,  $p<0.05$ ). The value for the effect size is  $r=0.44$  indicating a medium effect size. This is also a substantial finding.

One may wonder why there is a difference in the tails for the three Mann-Whitney tests conducted above i.e. argumentation and freeform, argumentation and timeline and timeline and freeform tested with two tails, one tail and two tails respectively (See table 4-3). This is because the directions of the hypothesis were set from the outset. Referring back to the introductory section of this thesis, there was a hypothesis that timeline would perform better than argument (one direction) but none was set for when the freeform condition was involved.

<b>Conditions</b>	<b>Test Tails</b>
Argument and Freeform	Two tailed
Argument and Timeline	One tailed
Timeline and Freeform	Two tailed

Table 4-3: The conditions and their test tails for the Mann-Whitney tests

### 4.1.6 Engagement

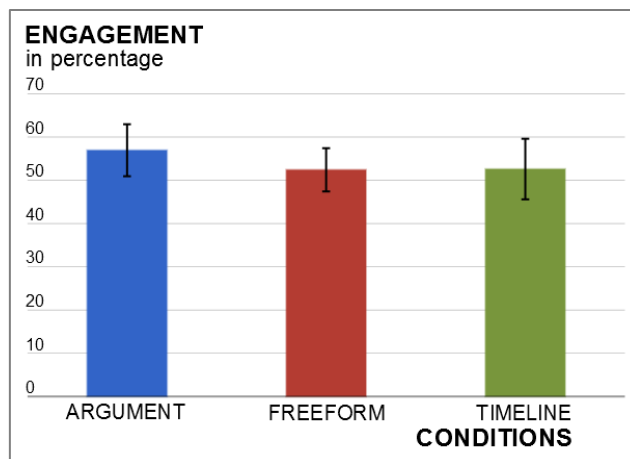

Figure 4-10: Bar graph showing the median engagement with error bars indicating the median absolute deviation

As was highlighted in the method section engagement is assessed with a questionnaire that contains four sections; focused attention, endurance, focused involvement and perceived usability. The engagement value is the average of the four of them. Figure 4-10 shows that participants in the argumentation condition (M=57%) have a higher engagement value than those in the timeline condition (M=53%) which is higher than those in the freeform condition (M=52%). However, the Kruskal–Wallis test reported no significant difference between the conditions ( $H=4.27$ ,  $df. = 2$ ,  $p>0.05$ ).

## 4.2 Summary of the study findings

A summary of the Kruskal-Wallis and Mann-Whitney test results are presented in the tables below.

Variable type	Dependent Variables	Significance
Performance	Duration	$p>0.05$
	Recall Verse Precision	$p>0.05$
	Understanding	$p>0.05$
User experience	Cognitive load	$p<0.05$
	Confidence	$p>0.05$
	Engagement	$p>0.05$

Table 4-4: Summary of Kruskal-Wallis test results

A Kruskal-Wallis test was conducted on all dependent variables. The summary of the result are presented in Table 4-4. It indicates that (1) there was no significant difference acquired in the duration, recall verse precision, understanding, confidence and engagement dependent variables. (2) There was a significant differences acquired in the cognitive load user experience dependent variable.

A Mann-Whitney U test was conducted on the cognitive load dependent variable. The summary of the results are presented in table 4-5. It indicated that (1) the participants in the argumentation condition significantly experienced higher cognitive load than those in the freeform condition and this finding is a substantial one (2) participants in the argumentation condition significantly experienced higher cognitive load than those in the timeline condition and this also is a substantial finding (3) there was no difference between the timeline and freeform conditions.

Dependent Variable	Direction	Significance	Effect size
Cognitive load	Argument (1.2) > Freeform (0.7)	$p<0.05$	$r= 0.54$
	Argument (1.2) > Timeline (0.9)	$p<0.05$	$r= 0.44$
	Timeline (0.9) > Freeform (0.7)	$p>0.05$	

Table 4-5: Summary of the Mann-Whitney test and effect size results



# Chapter 5

## Post hoc exploratory analysis

## Post hoc exploratory analysis

### 5.1 Overview

The findings from the study conducted to explore the impact that different types of external representational structuring have on performance and user experience during intelligence type investigations indicated that the participants in the freeform and timeline conditions experienced lower cognitive load while conducting their task than the participants in the argumentation condition. However, the user performance remained the same.

An informal review of the representations created by the freeform participants suggested that participants in the freeform condition constructed a hybrid representation using the timeline and argumentation approaches as well as others. We also observed that the participants in the constricted conditions (timeline and argumentation) deviated from their constrictions to a more hybrid approach.

In order to better understand the types of structuring that the participants actually did, an exploratory analysis was conducted on the video protocols to (1) analyse and compare representational structuring across conditions over time (2) understand the types of structuring that participants perform in the freeform condition.

### 5.2 Analysing and comparing representational structuring across conditions over time

In order to analyse and compare the types of structuring that the participants actually did, the participants video screen recordings were coded. A coding scheme was designed to analyse and characterise what the participants actually did over time. The coding scheme looked at structural activities interpretive codes in the context of information seeking objectifiable codes (see table 5-1). After the video screen recordings were coded, an activity timeline grid adopted from Attfield (2005) was used to show the distribution of information seeking and structural activities over time (see figure 5-1).

## 5.2.1 Coding scheme

The codes looked at interpretive structural activities in the context of objectifiable information seeking codes. The codes were divided into two types: information seeking and interaction activities and structural activities (see table 5-1). All participants were expected to perform the information seeking activities. Also, participants in the timeline and argument conditions were expected to perform timeline and argumentation structural activities respectively. That is, create a timeline and create an argumentation structure respectively.

The information seeking and interaction activities codes looked at information seeking and interaction activities that included searching, reviewing of documents, documenting notes, importing of document and merging documents with notes. On the other hand, the structural activities codes were interpretative codes that looked at structural activities such as timeline construction, justification, explanation and theme grouping. Table 5-1 shows the codes developed for the video protocol analysis.

<b>Information seeking and interaction activities</b> Submit search query Review document Documenting notes Importing document Merging: note with documents
<b>Structural activities</b> Timeline Justification Explanation Theme grouping

Table 5-1: Interpretive and objectifiable codes used for video protocol analysis

The *submit search query* code was applied when a user entered a search term into the search field of the search tool i.e. Microsoft Windows explorer and then hits the enter key.

The *review document* code was applied when a user was reviewing or browsing through a document.

The *documenting notes* code was applied when a user documents a note on the representation platform (i.e. Microsoft OneNote).

## Chapter 5 Post hoc exploratory analysis

The *importing document* code was applied when a user imported a document into the platform either by (1) dragging and dropping the document or (2) selecting 'import document' in the file menu or (3) documenting the documents identification number.

The *merging (note with document)* code was applied when a user merged a document with a note for easy repositioning (so that the document and note can be moved together easily).

The *timeline* code was applied when a user was performing activities which contributed to a timeline relation that is, to show the distribution of various events over time.

The *justification* code was applied when a user was performing activities which contributed to a justification relation that is, to provide justification or argumentative support for a claim.

The *explanation* code was applied when a user was performing activities which contributed to an explanation relation that is, to show that an event causes another event to happen.

The *theme grouping* code was applied when a user was performing activities which contributed to a theme grouping relation that is, to show that a group of events are related to each other by a single theme.

### 5.2.2 Activity timeline grid

The activity timeline grid was used to represent the participant's information seeking behaviour and structural activities over time (see figure 5-1). Each column represents a period of a minute and each row represents an activity. Where an activity occurs at least once in a given minute, the corresponding cell is filled with a colour. All minutes (cells) containing information seeking and behaviour activities i.e. activities that included searching, reviewing, documenting notes, importing document and merging of documents and notes were filled with the colour grey. In contrary, those minutes with structural activities i.e. activities that included some structuring such as timeline construction, justification, explanation and theme grouping were filled with different colours for easy discernment. Timeline construction, theme grouping, explanation, justification are coloured yellow, red, green and blue respectively.



## Chapter 5 Post hoc exploratory analysis

As stated earlier in section 5.2.1, information seeking and behaviour activities are the activities we expect all participants to perform. These activities include searching, reviewing of documents, documenting of notes, importing of documents and merging of documents and notes. Figure 5-2 indicates a similar distribution of information seeking and behaviour activities across conditions. The Kruskal-Wallis test reported no significant difference for searching ( $H=.024$ ,  $df. =2$ ,  $p>0.05$ ), reviewing ( $H=.450$ ,  $df. =2$ ,  $p>0.05$ ), documenting note ( $H=1.028$ ,  $df. =2$ ,  $p>0.05$ ), importing documents ( $H=.055$ ,  $df. =2$ ,  $p>0.05$ ) and merging documents and notes ( $H=2.659$ ,  $df. =2$ ,  $p>0.05$ ).

### 5.2.2.2 Average percentage time for performing structural activities

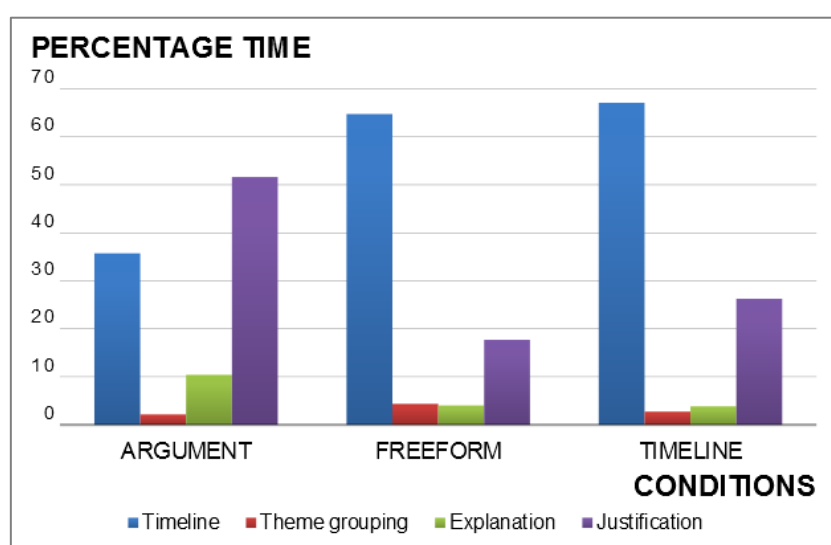

Figure 5-3: Clustered bar chart showing the average percentage time for performing structural activities across conditions

As stated in section 5.2, structural activities are those activities that include some structuring such as timeline, justification, explanation and theme grouping structuring. Figure 5-3 shows that (1) as expected, the timeline structural activity is more prominent in the timeline condition (67% of minutes featured some timeline construction). (2) Also as expected, the justification structural activity is more prominent in the argumentation condition (52% of minutes featured some justification construction). (3) However, the freeform condition exhibited a heterogeneous representation of structural activities with timeline structuring activities as the most prominent (65% of minutes featured some timeline construction).

Figure 5-3 also shows that the timeline and argumentation conditions moved away from their constrictions towards a more freeform approach i.e. elements of timeline can be found in the argumentation condition and elements of justification can also be found in the timeline condition as well as others. This could be because the participants of the timeline and argumentation conditions were told to construct their representations using timeline and argumentation structures respectively but were not constricted to do so. The Kruskal-Wallis test reported no significant difference for timeline ( $H=2.796$ ,  $df. =2$ ,  $p>0.05$ ), theme grouping ( $H=.362$ ,  $df. =2$ ,  $p>0.05$ ), explanation ( $H=.571$ ,  $df. =2$ ,  $p>0.05$ ) and justification ( $H=4.237$ ,  $df. =2$ ,  $p>0.05$ ).

### 5.2.3 Exploring user-generated representations in investigatory sensemaking tasks

During the process of analysing and comparing representational structuring across conditions over time, other observations were made; (1) the user representation grammar evolved, becomes increasingly sophisticated over time as their representation expanded, (2) users considered what they did in terms of the costs (time and cognition) it took to construct various relations (3) it seemed that these entities and multiple relation types are embedded within others and (4) the users seemed to be applying their own representation rules.

Using participant 7 as a case study, the user started their representation by dragging an information object from the search tool (the left of the figure 5-4) into the representation interface (the right of the figure). The information object is represented by an object icon (see figure 5-4). The number below the object icon represents the file name of the object.

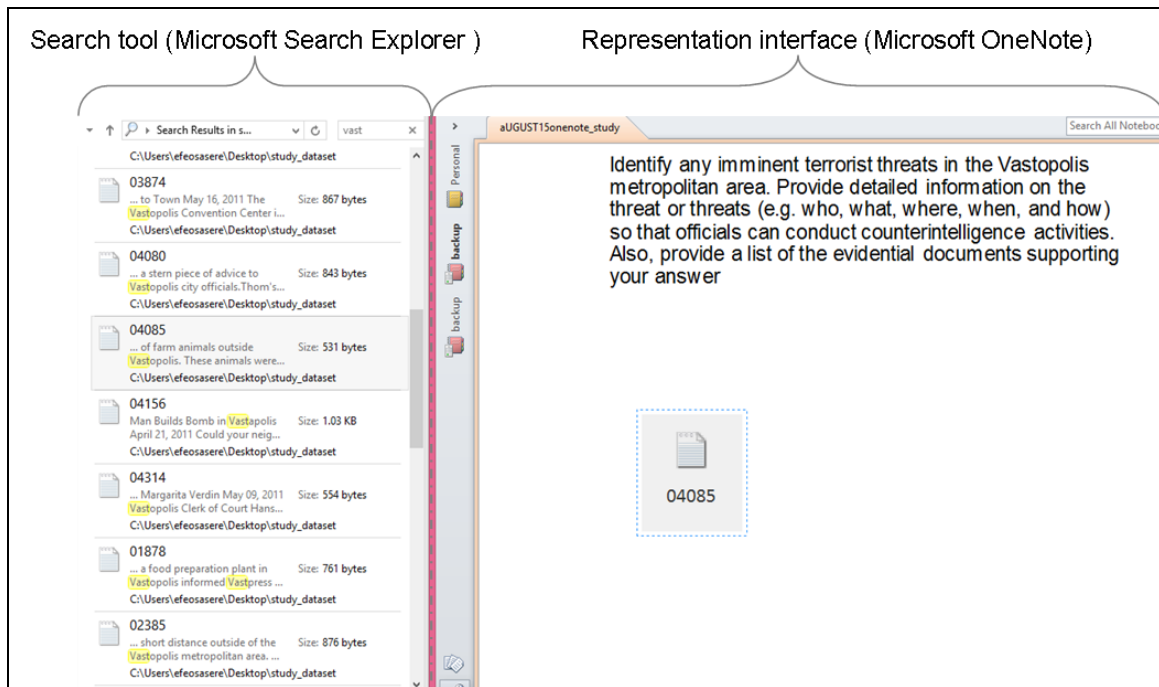

Figure 5-4: Representation showing one information object

The user representation was coded as they evolved using syntax trees. Implicit within these trees was a grammar (rule set) that described the user representation constituents and also their combinations. The syntax trees are constructed using graphical syntax trees generator software designed by Eisenbach & Eisenbach (2003) called *phpSyntaxTree*. The syntax tree reflects a more visual underlying rule (production rule) set of the user’s representation (Zander, 2009). For example, when the user dragged the information object into the representation interface, the syntax tree is generated (see figure 5-5). Table 5-2 shows the production rule for the syntax tree.



Figure 5-5: Syntax tree showing one information object

<Representation> → <doc>
--------------------------

Table 5-2: Production rule for syntax tree showing one information object



## Chapter 5 Post hoc exploratory analysis

The next step of the user representation, they inserted another information object (see figure 5-6). The syntax tree generated is provided in figure 5-7. Figure 5-7 shows that the representation now consists of two information objects. The production rule is provided in table 5-3. In order to indicate entities that contain a potentially infinite number of a given sub-entity in the production rule, the mathematical recursive rule was used. Recursive rules are rules that define an entity by reference to itself. For example, instead of writing `<doc>` multiple times, it is represented with `<doc>n`.

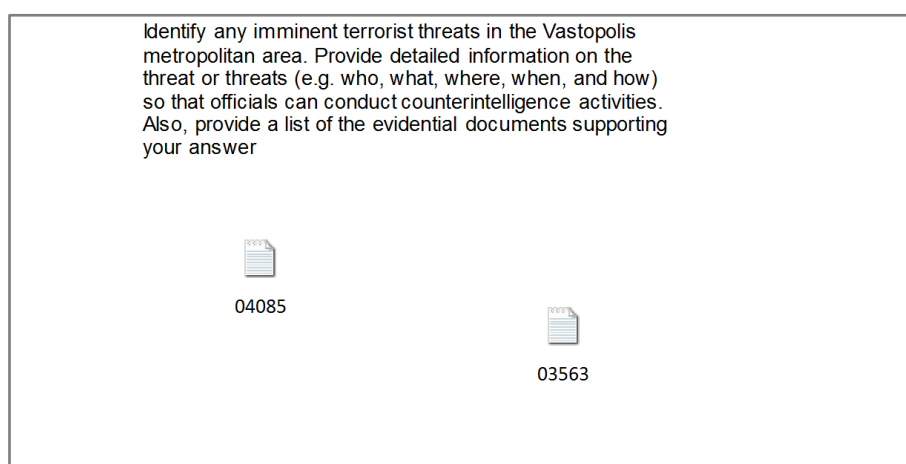

Figure 5-6: Representation showing two information objects

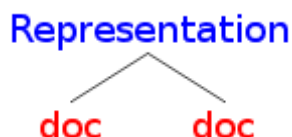

Figure 5-7: Syntax tree showing two information objects

<code>&lt;Representation&gt; → &lt;doc&gt;<sub>n</sub></code>
---

Table 5-3: Production rule for syntax tree showing two information objects

In the next step, the user merged the information object with the information objects title and date by linking them using an arrow (see figure 5-8). After observing several actions, the combination of an information object and its title and date was named as *an information object surrogate* because of the function it plays in the user representation. It functions as a proxy for the information object itself. The syntax tree of the representation is provided in figure 5-9. Table 5-4 shows the production rule for the syntax tree in figure 5-9.

## Chapter 5 Post hoc exploratory analysis

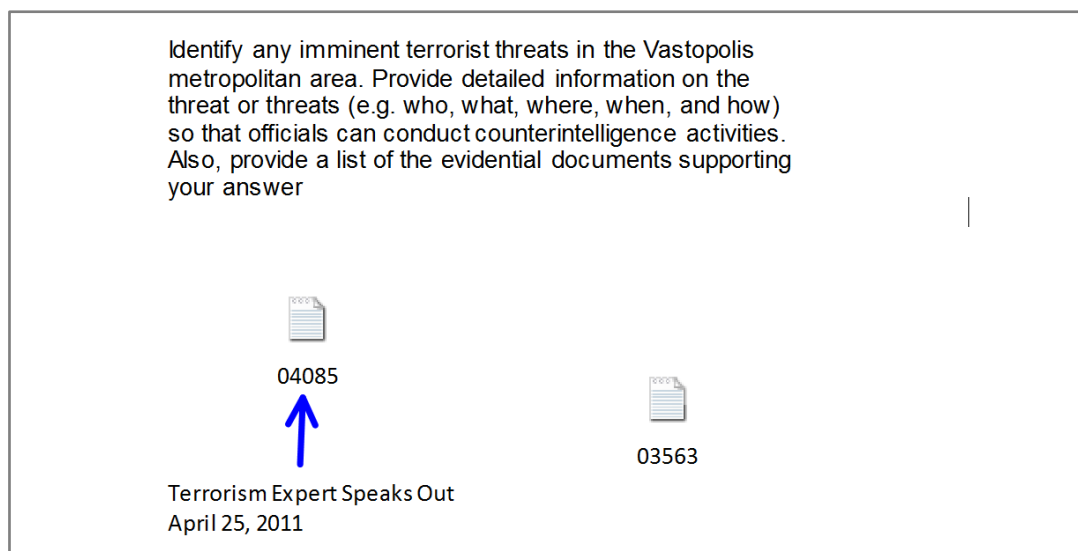

Figure 5-8: Representation showing one information object surrogate and one information object

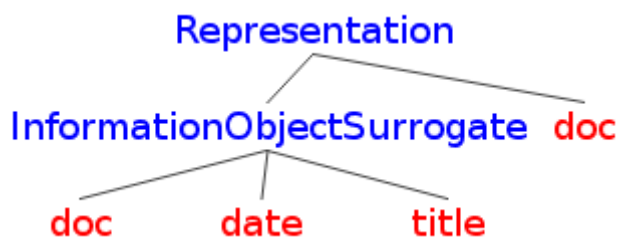

Figure 5-9: Syntax tree showing one information object surrogate and one information object

<code>&lt;Representation&gt; → &lt;Information object surrogate&gt; &lt;doc&gt;</code>
--

<code>&lt;Information object surrogate&gt; → &lt;doc&gt; &lt;date&gt; &lt;title&gt;</code>
--

Table 5-4: Production rule for syntax tree showing one information object surrogate and one information object

As the investigation continued, the representation language evolved 'on the fly'. The user also started to develop a rule set. They adopted the same approach making the single information object into another information object surrogate. In figure 5-10, the user representation consisted of two information object surrogates. The syntax tree representation is provided in figure 5-11. Table 5-5 shows the production rule.

## Chapter 5 Post hoc exploratory analysis

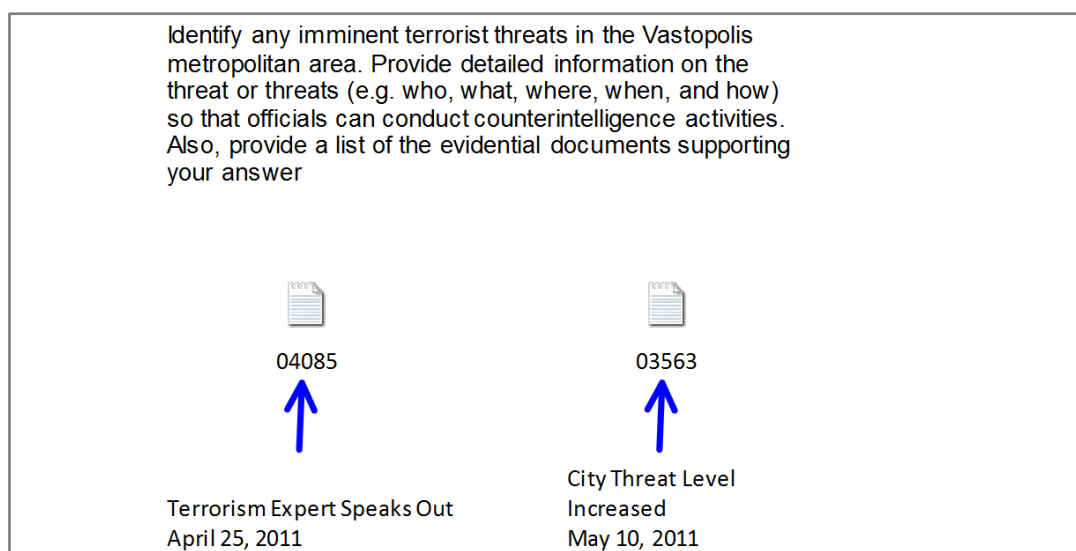

Figure 5-10: Representation showing two information object surrogates

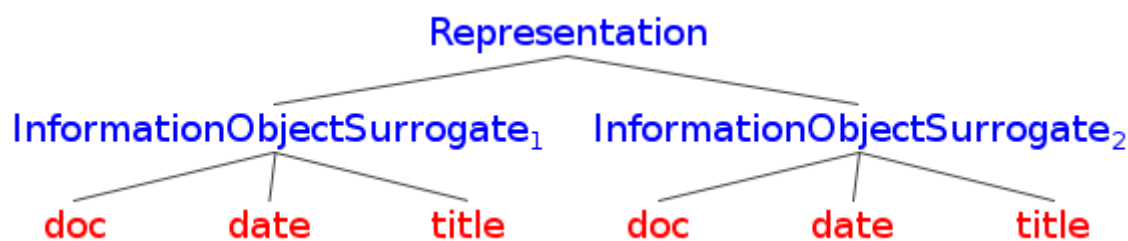

Figure 5-11: Syntax tree showing two information object surrogates

<code>&lt;Representation&gt; → &lt;Information object surrogate&gt;<sub>n</sub></code>
--

<code>&lt;Information object surrogate&gt; → &lt;doc&gt; &lt;date&gt; &lt;title&gt;</code>
--

Table 5-5: Production rule for syntax tree showing two information object surrogates

As the investigation continued, they adopted a quicker approach in creating the information object surrogates (see figure 5-12). This was done by merging the constituents of the information object together rather than spending more seconds to draw arrows i.e. arrows exchanged for proximity to signal association. This we assume was a more efficient use of space and easier to create. That is, they were also considering what they did in terms of the cost (time) it took to create those relations. The syntax tree and production rule remains the same as in figures 5-11 and table 5-5 respectively.

## Chapter 5 Post hoc exploratory analysis

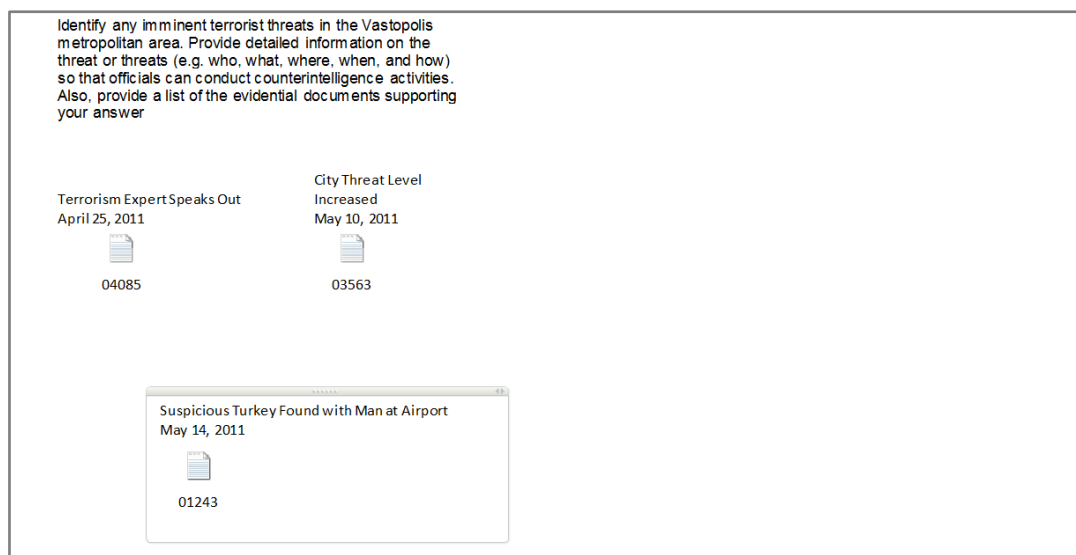

Figure 5-12: Representation showing multiple information objects surrogates

As they continued with their investigations, when they reviewed an information object they considered as relevant, they created information object surrogates of them all. Also, as the investigation continued, they started to see similar themes within the information objects. So, they needed to expand the language they had already set by adopted a new language of theming (thematic association) (see figure 5-13). Figure 5-13 shows themed information object surrogates. The syntax tree generated and production rule is provided in figure 5-14 and table 5-6 respectively.



Figure 5-13: Representation showing multiple information objects surrogates in a theme

## Chapter 5 Post hoc exploratory analysis

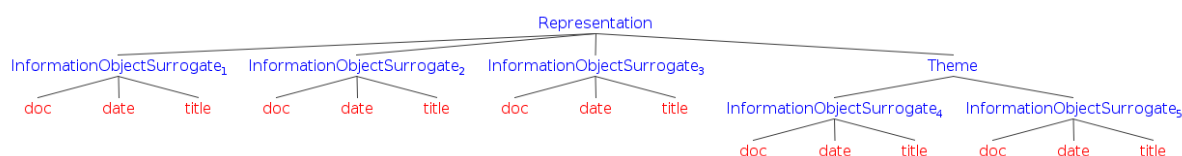

Figure 5-14: Syntax tree showing multiple information objects surrogates and a theme

<code>&lt;Representation&gt; → &lt;Theme&gt; &lt;Information object surrogate&gt;<sub>n</sub></code>
<code>&lt;Theme&gt; → &lt;Information object surrogate&gt;<sub>n</sub></code>
<code>&lt;Information object surrogate&gt; → &lt;doc&gt; &lt;date&gt; &lt;title&gt;</code>

Table 5-6: Production rule for syntax tree showing multiple information objects surrogates and a theme

The next phase, colour coding was introduced to distinguish themes (see figure 5-15). This we assume leverages pre-attentive processing. Pre-attentive processing is “the ability of the low-level human visual system to rapidly identify certain basic visual properties” (Healey & Enns, 2012, p. 1170). From figure 5-15, we can also observe that the information object surrogates are chronologically sorted within their specific themes. Here, the user had a timeline relation embedded in a theme relation. The syntax tree generated and production rule are provided in figure 5-16 and table 5-7 respectively.

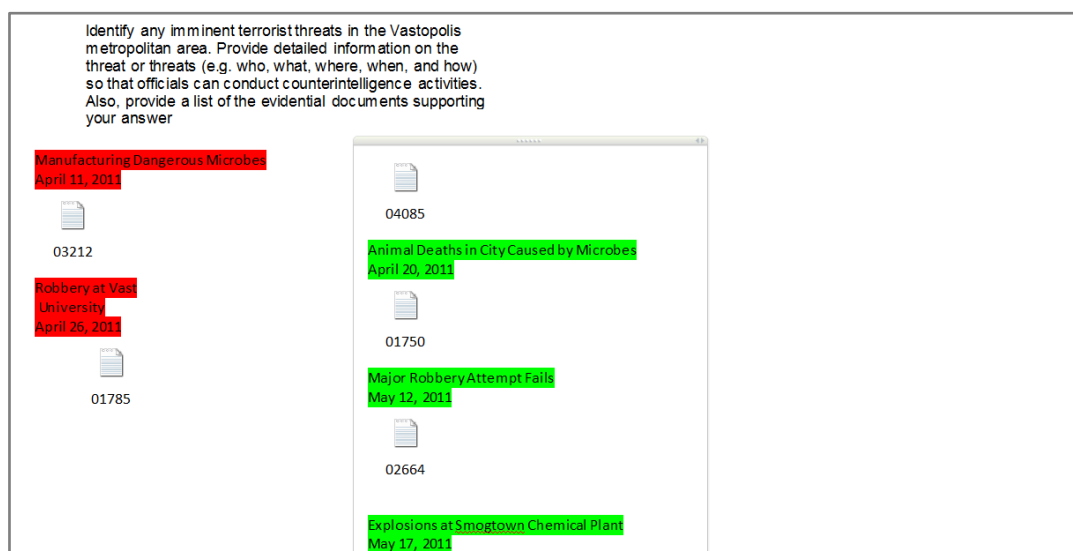

Figure 5-15: Representation showing colour coded themes

**Chapter 5** Post hoc exploratory analysis

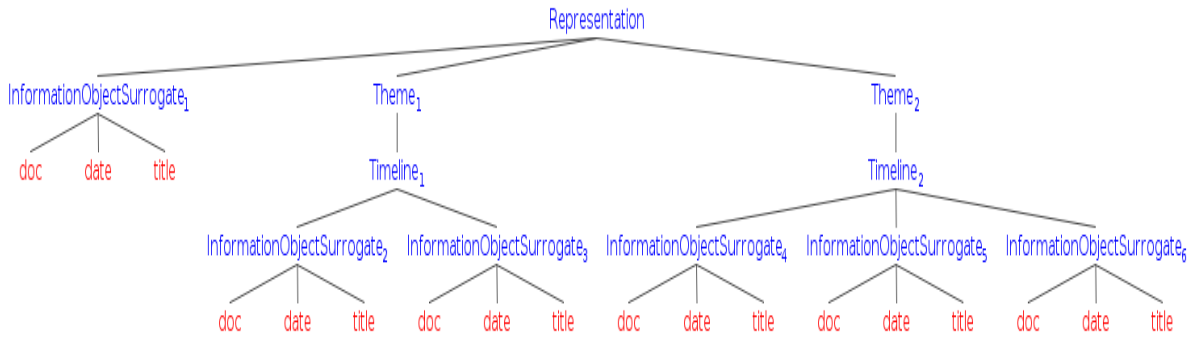

Figure 5-16: Syntax tree showing a timeline relation embedded in a theme

<code>&lt;Representation&gt; → &lt;Theme&gt;<sub>n</sub> &lt;Information object surrogate&gt;</code>
<code>&lt;Theme&gt; → &lt;Timeline&gt;</code>
<code>&lt;Timeline&gt; → &lt;Information object surrogate&gt;<sub>n</sub></code>
<code>&lt;Information object surrogate&gt; → &lt;doc&gt; &lt;date&gt; &lt;title&gt;</code>

Table 5-7: Production rule for syntax tree showing a timeline relation embedded in a theme

Now, every relevant information object to their investigation was turned into information object surrogates and they were sorted chronologically to form a timeline relation and this timeline relation was embedded in a theme relation (see figure 5-15). As the user continued with their investigation, they had timelines that were embedded in themes and also themes that were not chronologically sorted. Figure 5-17 and table 5-8 shows the final generated syntax tree and production rule respectively. Where IOS, D, T and Dt refers to Information object surrogate, doc, title and date respectively. Note that the bar “|” is an OR operator.

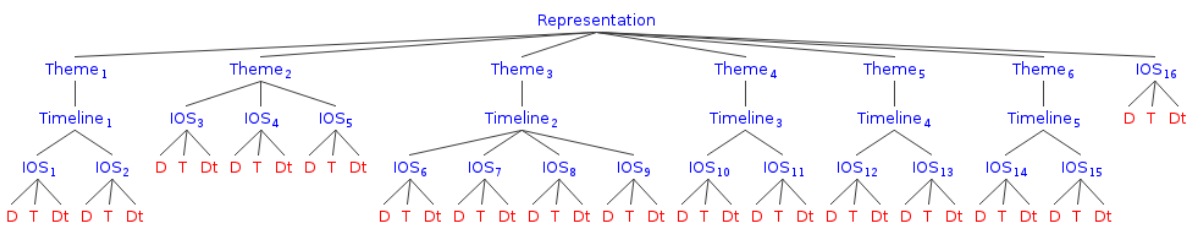

Figure 5-17: Syntax tree showing all the constituents of the user's representation

<code>&lt;Representation&gt; → &lt;Theme&gt;<sub>n</sub> &lt;Information object surrogate&gt;</code>
<code>&lt;Theme&gt; → &lt;Timeline&gt;   &lt;Information object surrogate&gt;<sub>n</sub></code>
<code>&lt;Timeline&gt; → &lt;Information object surrogate&gt;<sub>n</sub></code>
<code>&lt;Information object surrogate&gt; → &lt;doc&gt; &lt;title&gt; &lt;date&gt;</code>

Table 5-8: Production rule for syntax tree showing all the constituents of the user's representation

### 5.2.3.1 Conclusion

In conclusion of this section (section 5.2), we can say that (1) the timeline and argumentation conditions tend towards the freeform condition. That is, if users are left to their own devices in a sensemaking task (i.e. without adequate constrictions), users will create hybrid type representations consisting of various structural activities while having similar information seeking and interaction behaviours. (2) The users representation grammar evolves, becomes increasingly sophisticated over time as their representation expands, (3) users will consider what they do in terms of the costs (time and cognition) it takes to construct various relations and it seems that these entities and multiple relation types are embedded within others.

## 5.3 Understanding the embedding of structural conventions in freeform conditions

There is a reason to believe from the section on analysing and comparing representational structuring across conditions over time (see section 5.2) that when users are left to their own devices in a sensemaking task, they create complex heterogeneous representations consisting of various entities and multiple relation types. Further, it seems that these entities and multiple relation types are embedded within others (see section 5.2.3) so there is a need for a hierarchical theory to unpack them.

Also we assume users do what they do for a reason. When provided with some tools to solve a sensemaking problem, they will use those tools in a way that supposedly supports their cognition. They will, presumably, also consider what they do in terms of the costs (time or cognition) it takes to do it but, what they do reflects their needs. So by understanding what they do, we are in a better position to understand their needs and therefore to design for them. By understanding representation elements and how they relate to each other (their relations), we can think about how to enable users to create them and relate them easily. Also, we can think about why they find them helpful and also the frequency with which they create them in different circumstances. Hence, it possibly represents a way of characterising and measuring what is important as well as the impact of sensemaking manipulations.

### 5.3.1 The functional theory of embedded representational structuring (ERST)

What we wanted to do is to find a theory that helps to characterise and describe these complex heterogeneous representations primarily in terms of their relations and elements. In order to do this, a functional theory of embedded representational structuring (ERST) was developed. The functional theory of embedded representational structuring (ERST) describes and characterises embedded representational structuring primarily in terms of their function (roles or use) in a representation. The significance of creating a functional theory of embedded representational structuring is that it provides an abstraction of the rules underlying a representation. That is, a way of understanding what the units of a representation are. Also, how they can be combined with the rules that the user has set up and these rules are important because they provide a basis for interpretation. Therefore analysis of multiple entities and element relation seems appropriate.



## Chapter 5 Post hoc exploratory analysis

The theory had to take an interpretative analysis path because we are interested in the meaning that certain relations had to the user, irrespective of their spatial features. We are making an attempt to capture user intent based on the analyst's interpretation of intended meaning and a given meaning or intent may be represented in any number of ways. It is the intent that the user captures in their representation. For example, the user expressing that two things are related in virtue of one providing an explanation of the other, or that they are related by a single theme, or that they are distributed over time. So, the analysis had to be anchored in meaning and not form. The approach is not guided by objectively observable features, 'not positivist' like the approach used by Kong, Zhang, & Zeng (2006) to describe the physical layout and abstract structure of graphical user interfaces that determine relationships based on spatial relationships and a fixed grammar but 'interpretative' like the approach used by Mann & Thompson (1988) in the definition of the Rhetorical Structure Theory (RST).

*RST "...is a descriptive theory of a major aspect of the organisation of natural text. It is a linguistically useful method for describing natural texts, characterising their structure primarily in terms of relations that hold between parts of the text."* (Mann & Thompson, 1988 p. 243).

Mann & Thompson (1988) indicated that there are no particular indicators or cues that signal a particular relation. That it is down to the interpretation of the analyst.

The difference between the Embedded Representational Structuring Theory (ERST) and Rhetorical Structure Theory (RST) lies in their mapping and the independence of their parts. RST analyses text and text are linear constructs (one dimensional in nature). In contrary the ERST analyses representation structures and representations are best described using more than one dimension (multi-dimensions). For example, complex objects such as tables, may be difficult to express in RST. What are their constituents? Are they rows and columns? The problem is that RST assumes that each object is independent (Mann & Thompson, 1988) which leads to a "mono-hierarchical mapping" (Will & Will, 2009). In contrary, that is not the case with ERST. It assumes that relations can be independent and also dependent on other relations or elements. That is, a single relation can be part of other relations leading to a "poly-hierarchical mapping" (Will & Will, 2009). This definitely transgresses the axiom of RST.

Since the work is interpretative, it has to follow the principles of interpretative research. Klein & Myers (1991) provided a set of principles for conducting and evaluating interpretative field studies in information systems of which two are particularly important here or applicable to

the current work: the fundamental principle of the hermeneutic circle and the principle of abstraction and generalisation.

*The fundamental principle of the hermeneutic circle* is an iterative process that follows the idea that from the understanding of parts and their relationships, we come to understand a complex whole and from the whole we come to understand the parts (Klein & Myers, 1991). It is only through this hermeneutic circle understanding of “parts to whole and from the whole back to its parts” that we can understand each part and the entire representation. So every single representation was attended to in similar matter.

*The principle of abstraction and generalisation* requires providing a theory from the data collected and then provide idiographic details to support that theory (Klein & Myers, 1991) i.e. relating the idiographic details acquired from the interpretation of the data to theoretical principles. This allows the reader to be able to follow the researcher’s theoretical insight.

### 5.3.1.1 How the theory was generated

The Embedded Representational Structure Theory (ERST) was generated from (1) the analysis of the freeform participants representations using the fundamental principle of the hermeneutic circle and the principle of abstraction and generation. The fundamental principle of the hermeneutic circle was used to get an understanding of every representation and their units. This was then generalised and backed up with idiographic details. (2) The analysis of the representation syntax trees and their production rules (see section 5.2.3).

### 5.3.1.2 Relations of the Embedded Representational Structure Theory

The *relations* of the ERST consist of elements and *elements* are constituents of relations. For example the *information object surrogate* relation has *summary*, *source* and *date* as its elements. An element can either be mandatory or optional, a *mandatory element* is an element that a relation must have and an *optional element* qualifies a relation and can be added to a relation but does not have to be present. For example in the information object surrogate relation, the mandatory element is the *summary* element and the optional elements are the date and source elements.

Relations are *polyhierarchical* meaning that an element can independently be a member of more than one relation resulting in a polyhierarchical syntax tree. This we have discussed in the ERST section earlier (see section 5.3.1). An example is the *justification* relation which is

expressed as a combination of a *claim* or *imperative* and its *evidential support* but, in one of the examples of a *justification* relation, a *justification* relation is expressed as a combination of a *claim* element and a *timeline* relation acting as its evidential support.

Relations are defined in functional terms. For example the *explanation* relation elements are *explanans* and *explanandum* they are defined by their roles in the representation as intended by the user as well as the elements that constitute them.

### 5.3.1.3 Relations and their definitions

A number of relations and their elements were identified. They are presented in the table 5-9

<b>Information object surrogate relation</b> Mandatory element: <i>Summary (can either be title or gist or both)</i> Optional element: <i>Date</i> Optional element: <i>Source</i>
<b>Timeline relation</b> Multiple <i>Information object surrogate relation</i> with mandatory date element
<b>Themed grouping relation</b> Multiple <i>Information object surrogate relation</i>
<b>Explanation relation</b> Mandatory element: <i>Explanans</i> Mandatory element: <i>Explanandum</i>
<b>Justification relation</b> Mandatory element: <i>Claim</i> Mandatory element: <i>Evidential support</i>

Table 5-9: Relations and elements of the ERST

#### 5.3.1.3.1 Information object surrogate relation

An information object surrogate relation is a combination of a *summary* element (which can either be a *gist* or a *title*), a *date* and *source* element where the summary element is a mandatory element and the date and source elements are both qualifiers (optional elements) (see table 5-10). The *information object surrogate* relation stands as a proxy of the information object itself (see section 5.2.3). It allows the user to review an information object at a glance and access its contents easily. An *information object* could be a document or a video or sound file etc.

<b>Information object surrogate Relation</b> Summary ( title or gist or both) <i>mandatory element</i> Date <i>optional element</i> Source <i>optional element</i>
---

Table 5-10: Information object surrogate relation and elements

### *Information object surrogate elements*

#### Summary element

The summary element is a statement of content of an information object. It consists of a *gist* or *title* or both. The *title* is the title or headline of an information object while the *gist* is a summary or a significant subset of the object's content. It allows the user to view the central idea of an information object without reopening the actual object i.e. it reminds the user of the significant content in the information object.

#### Date element

The *date* element allows the user to keep track of events as they occur. It is the date that an information object is published or that a reported event occurred.

#### Source element

The source element is an information object icon or text string with the information object identification number (e.g. 03040) or a combination of both. The *source* element acts as a reference or pointer to the information object itself. It allows the user to have a ready access to the actual information object i.e. a means through which the user can refind the original information object.

### *Examples of information object surrogate relation*

The *information object surrogate* can occur in various ways. Figure 5-18 shows an example created by participant 16. In the study, the user created these by (1) opening an information object from the search tool (Microsoft Windows Explorer) (on the left) by clicking on it to open it (figure 5-19 shows a sample of the information object when opened). For example, they click on the information object inside the red rectangle on the left which opens it in figure 5-19 (2) reviewing it, (3) producing a summary of the information object content (*gist* element) on the right and (4) dragging an information object icon that represents a *source* from the search tool that displays the information objects into the representation interface (Microsoft OneNote). The combination of both the source and the gist elements (highlighted in the red rectangle on the right in figure 5-18) forms an information object surrogate.

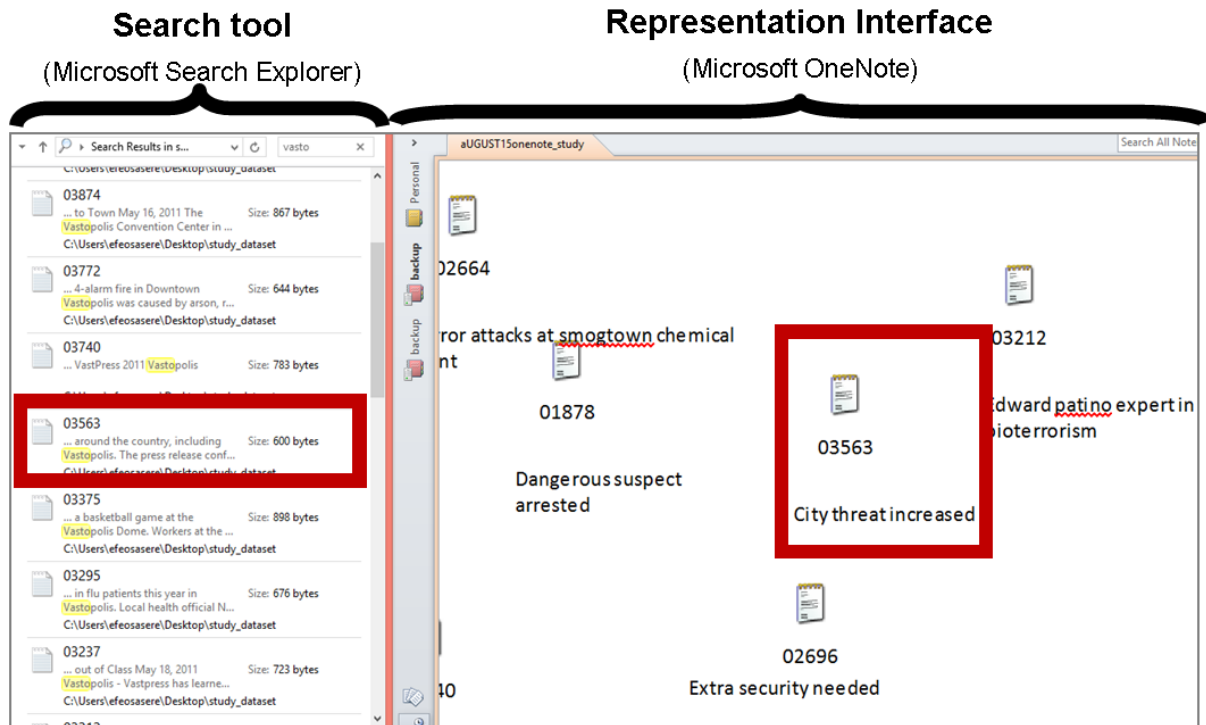

Figure 5-18: Information object surrogate relation with gist and source elements created by participant 16

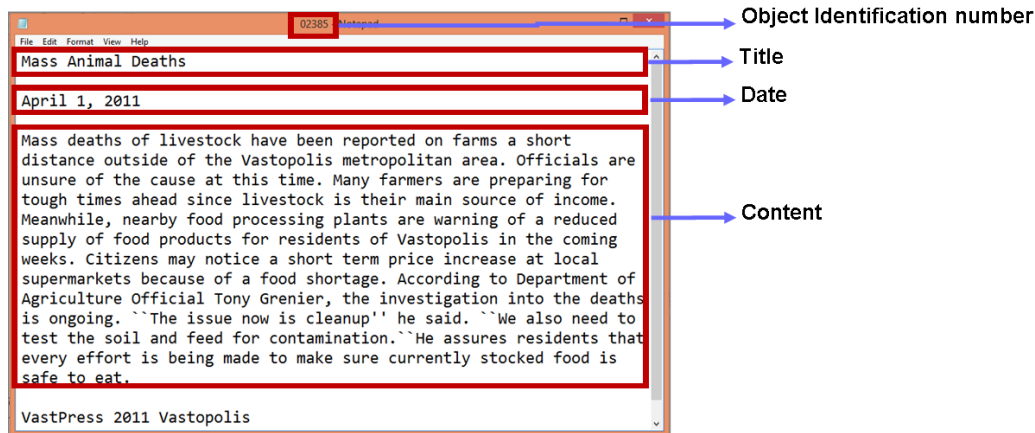

Figure 5-19: Sample information object (document) when opened

Figures 5-20 and 5-21 shows another example of the *information object surrogate* relation created by participants 9 and 25. In the study, the users created these by (1) opening an information object from the search tool (Microsoft Windows Explorer), (2) reviewing it, (3) producing a summary of the information object content representing the *gist* (4) documenting the date the information object was published (date element) and (5) dragging an information object icon that represents a *source* from the search tool that displays the information objects into the representation interface. The combination of the date, source and gist

## Chapter 5 Post hoc exploratory analysis

elements (highlighted in the red rectangle on the right in figures 5-20 and 5-21) forms an information object surrogate.

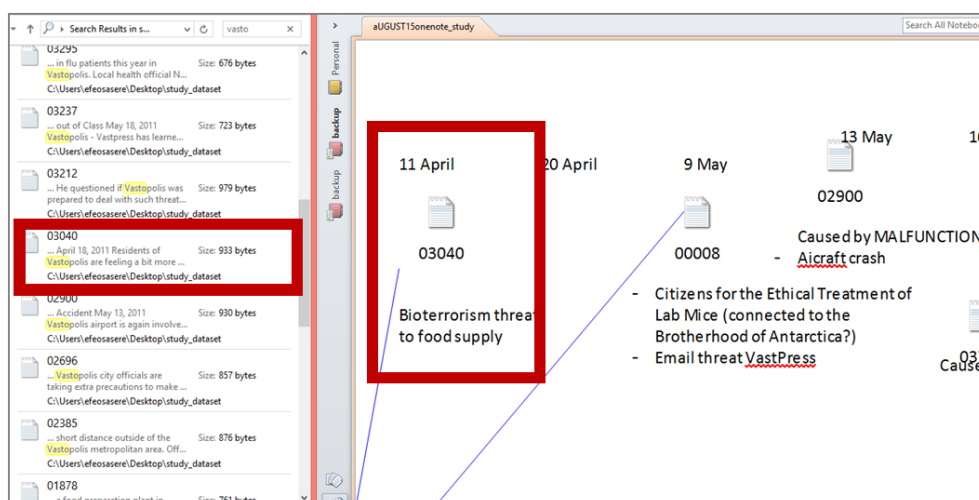

Figure 5-20: Information object surrogate relation with gist, source and date elements created by participant 9

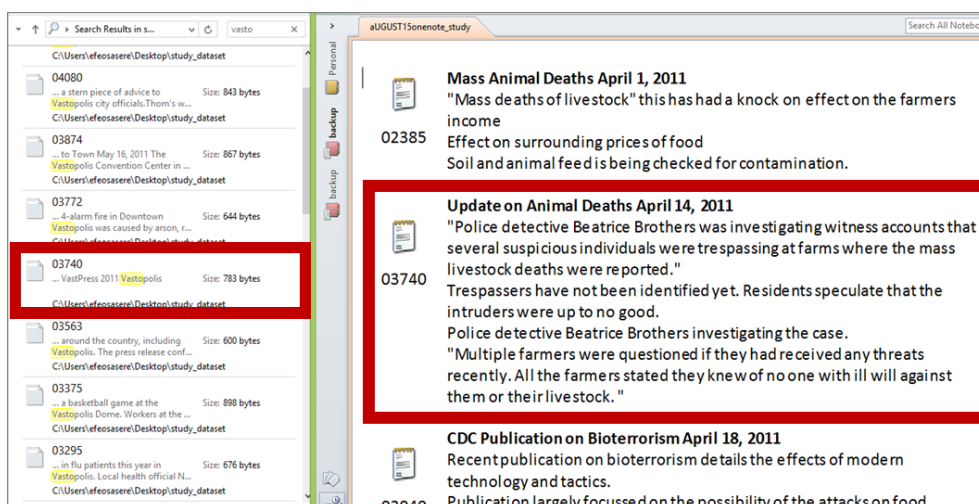

Figure 5-21: Information object surrogate relation with gist, source and date elements created by participant 25

An alternative to the example in figures 5-20 and 5-21 is shown in figure 5-22. The only difference here is the last step where instead of dragging an information object icon that represents a *source* from the search tool, the user simply produced (typed out) the document identification number (e.g. 04085) that represents the *source* of the information object.

## Chapter 5 Post hoc exploratory analysis

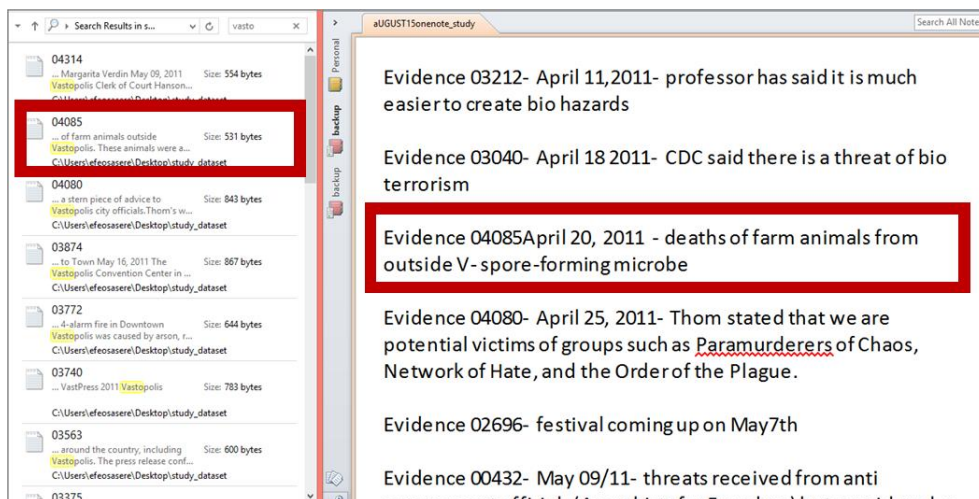

Figure 5-22: Information object surrogate relation with gist, source and date elements created by participant 20

Other information object surrogates examples with (1) title and date, (2) title, source and date and (3) title, gist, source and date elements combinations can be found appendix E.



### 5.3.1.3.2 Timeline relation

A timeline relation is a combination of multiple (more than one) *information object surrogate* relations (see table 5-11) that includes a mandatory *date* element chronologically sorted horizontally or vertically from the least recent to the most recent event or vice versa. The timeline relation allows the user to review multiple events in chronological order.

**Timeline relation**  
Multiple *Information object surrogate relation* with mandatory date element

Table 5-11: Timeline relation and elements

#### Examples of timeline relation

The timeline relation occurs in various ways. Figure 5-23 and 5-24 shows examples created by participants 3 and 25. In the study, the users created these by (1) creating multiple information object surrogates (see information object surrogate section 5.3.1.3.1) using the information object in the red squares on the left. They created information object surrogates consisting of the information object title (*title element*), date of publication (*date element*), significant subset of the content of the information object or the summary of its content (*gist element*) and an information object icon that represents a *source element*. (2) Sorting them chronologically in a horizontal line (from left to right) so that the least recent date is at the left and the most recent date is at the right of the rectangle on the right of figure 5-23 or vertical line (from top to bottom) so that the least recent date is at the top and the most recent is at the bottom of figure 5-24.

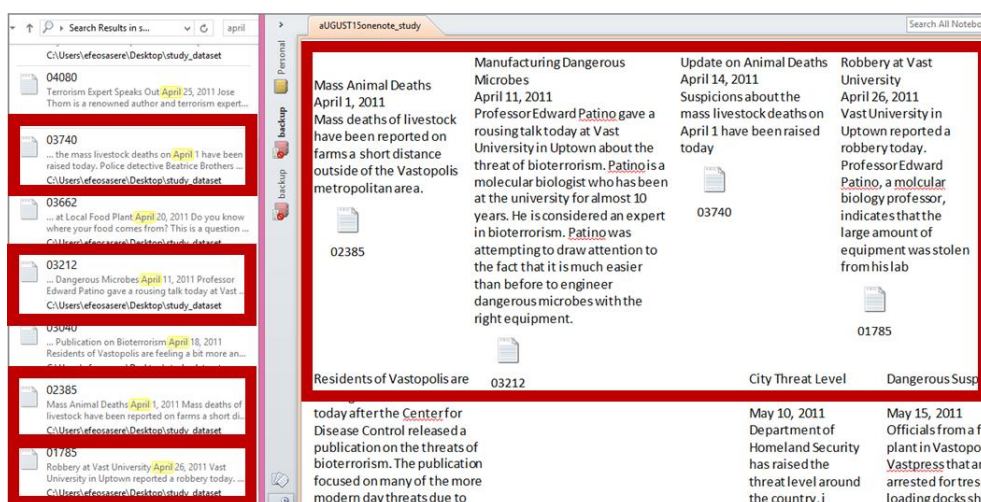

Figure 5-23: Timeline relation with title, date, gist and source elements created by participant 3



## Chapter 5 Post hoc exploratory analysis

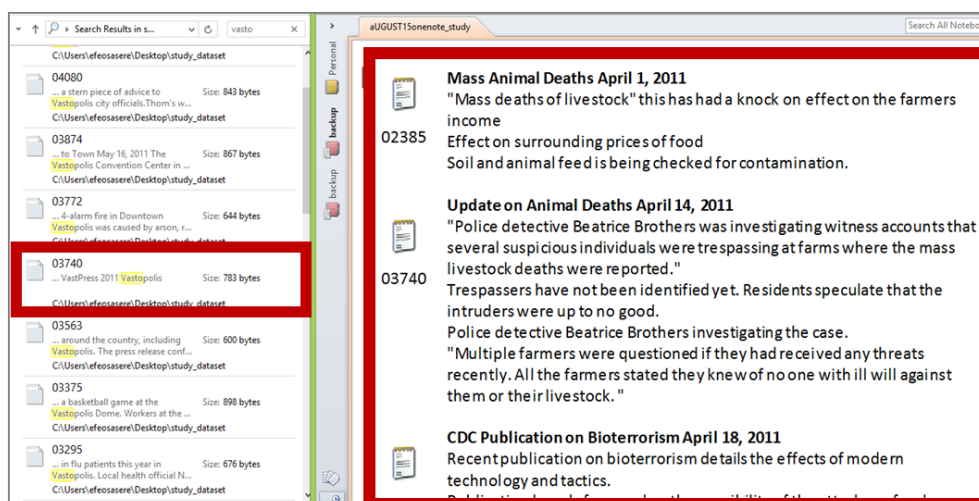

Figure 5-24: Timeline relation with date, gist and source elements created by participant 25

Figure 5-25 shows another example of the *timeline* relation which was created by participant 7. In the study, the user created these by (1) creating multiple information object surrogates (see information object surrogate section 5.3.1.3.1) consisting of the information object title, date of publication and an information object icon that represents a *source* element. (2) Sorting them chronologically in a vertical line (from top to bottom) so that the least recent date is at the top and the most recent date is at the bottom.

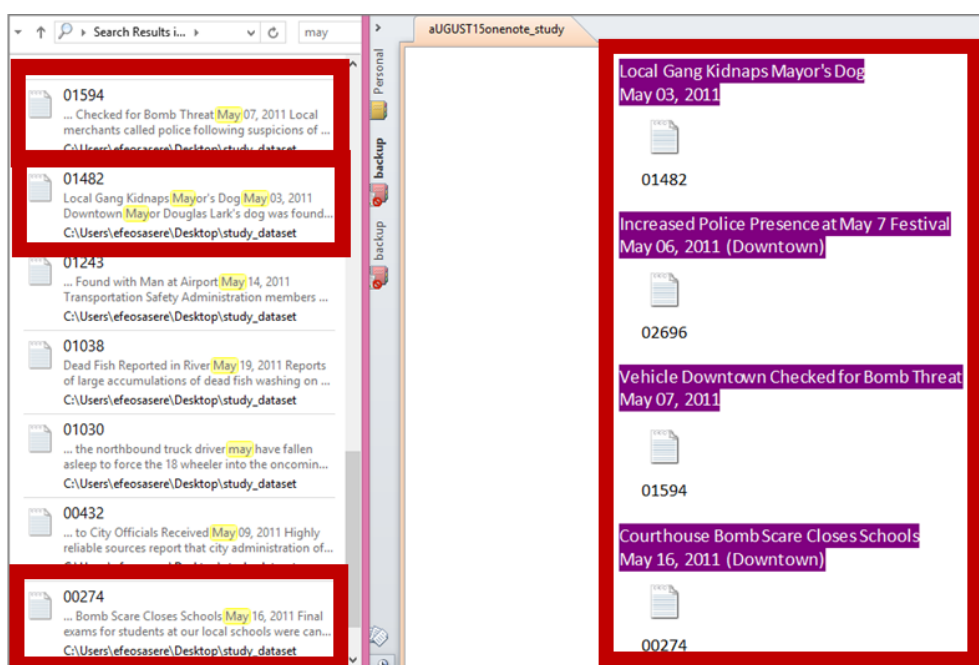

Figure 5-25: Timeline relation with title, date and source elements created by participant 7

## Chapter 5 Post hoc exploratory analysis

Other timeline examples with (1) title, date and gist and (2) date, gist and source elements combinations chronologically sorted together can be found in appendix E.

### 5.3.1.3.3 Themed grouping relation

A *themed grouping* relation is a combination of multiple (more than one) *information object surrogate* relations (see table 5-12) on a given theme or topic. The themed grouping relation allows the user to review multiple events of the same theme.

#### Themed grouping relation

Multiple *Information object surrogate relation*

Table 5-12: Themed grouping relation and elements

#### Examples of themed grouping relation

The *themed grouping* relation occurs in various ways. Figure 5-26 shows one example created by participant 9. In the study, the user created these by (1) creating multiple information object surrogates (see information object surrogate section 5.3.1.3.1) consisting of the summary of the content of the information object (*gist element*) and an information object icon or information object identification number that represents a *source element*. (2) Then they drew a line to relate them together and documented (typed out) "*threat*" to indicate that they are both linked by a single *theme "threat"*.

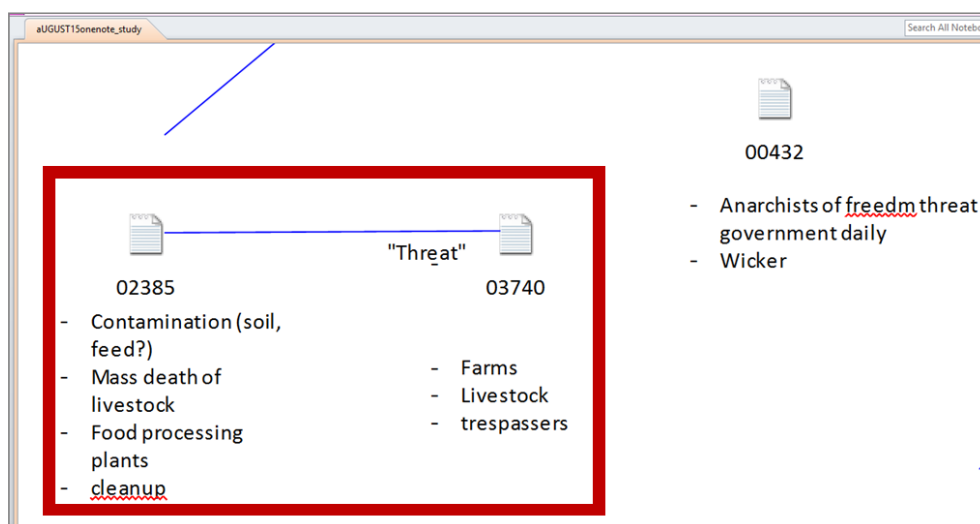

Figure 5-26: Themed grouping relation created by participant 9 using lines

## Chapter 5 Post hoc exploratory analysis

Figure 5-27 shows another example of the theme grouping relation which was created by participant 7. In the study, the user created these by (1) creating multiple information object surrogates consisting of the information object title, date of publication (*date element*) and an information object icon that represents a *source* element. (2) Sorting them chronologically in a vertical line so that the least recent date is at the top and the most recent at the bottom. (3) Then, highlighted various surrogates and filled them with colour to indicate that they are related to a *single theme*.

The information object surrogate filled with the red colour in figure 5-27 represents a “*bioterrorism equipment*” theme. While the information object surrogate filled with purple, yellow and blue colours represents “*isolated cases*”, “*citizens for ethical treatment of lab mice*” which is one of the potential terrorist groups and “*bioterrorism*” respectively.

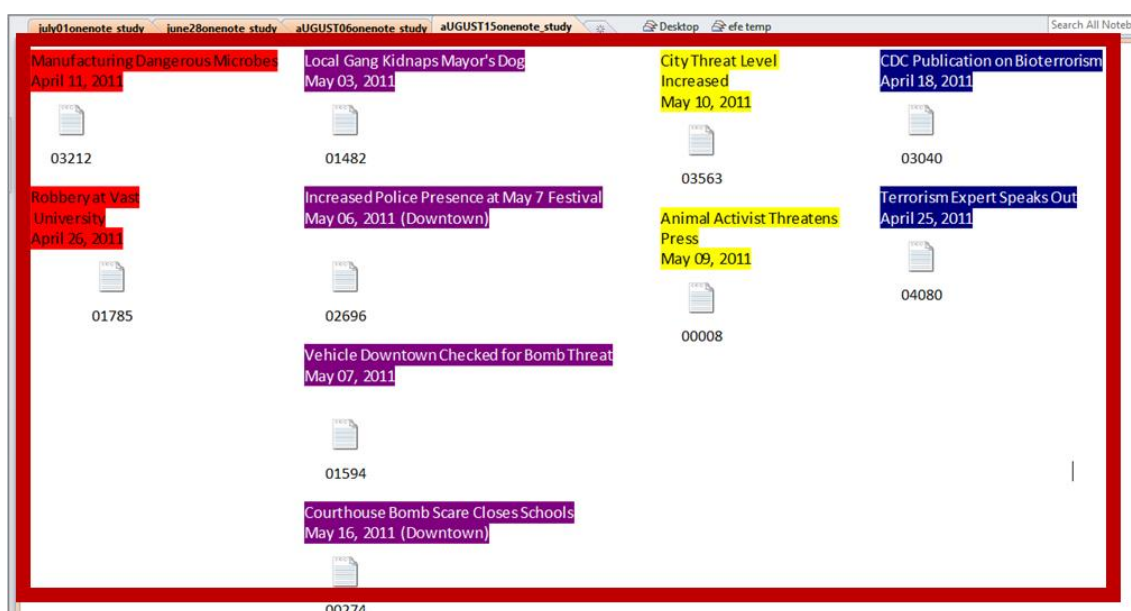

Figure 5-27: Themed grouping relation created by participant 7 using colour

### 5.3.1.3.4 Explanation relation

An *explanation* relation is a combination of two information object surrogate relations which are linked through an explanatory relation with one in the role of *explanans* and the other taking the role of *explanandum* (see table 5-13). The explanation relation allows the user to express that an event explains why another event occurred or to express what caused an event and the resulting effect of that cause.

<b>Explanation relation</b> Explanans <i>mandatory element</i> Explanandum <i>mandatory element</i>
---

Table 5-13: Explanation relation and elements

#### *Explanation elements*

##### Explanans element

The *explanans* is an element that is part of an explanatory relation whose role is to offer explanation. It allows the user to express the cause of an event.

##### Explanandum element

The *explanandum* is an element that is part of an explanatory relation whose role is to be explained. It allows the user to express the effect of a cause of an event.

#### *Examples of explanation relation*

The *explanation* relation occurs in various ways. Figure 5-28 shows one example created by participant 3. The user created these by first relating two *information object surrogates* together using arrows where the information object surrogate at the top left acts as the *explanans* and the *information object surrogate* at the bottom right acts as the *explanandum*. The temporal order at which the events occurred helped us to answer the question of which information object surrogate is explaining which. We know this because of the temporal order at which the events occurred, the first in April 26 and the other May 18.

## Chapter 5 Post hoc exploratory analysis

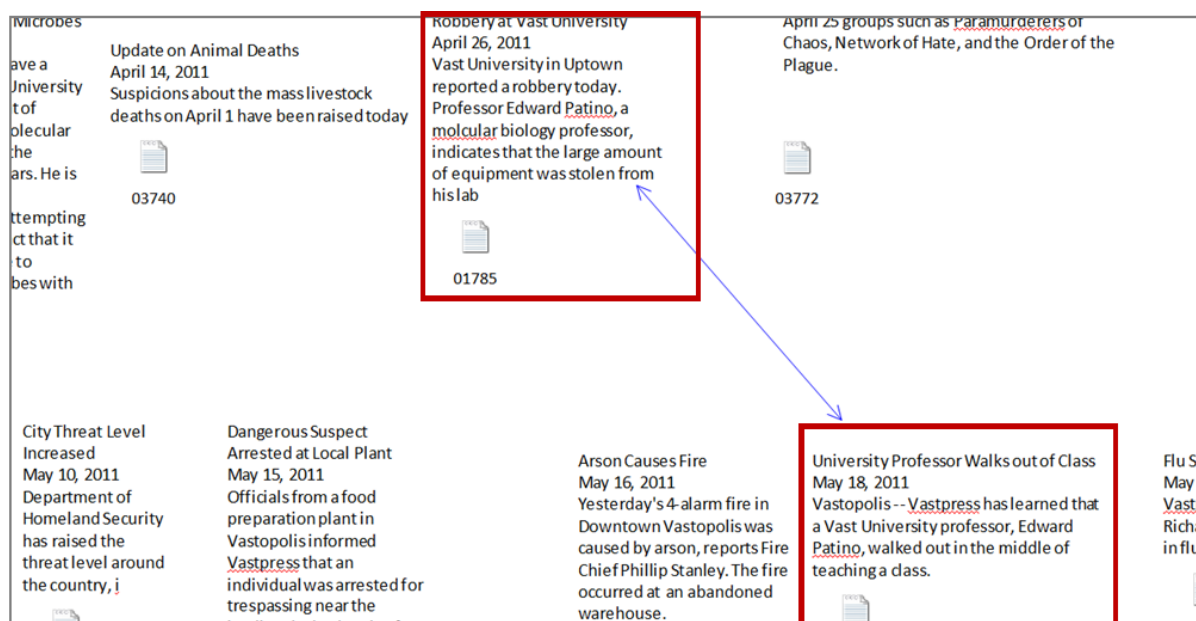

Figure 5-28: Explanation relation with two information object surrogates created by participant 3

Figure 5-29 shows another example of the explanation relation which was created by participant 3. The user creates these by relating three *information object surrogate* together using arrows. The information object surrogate at the bottom left acts as an explanans explaining the information object surrogate at the top. The information object surrogate at the top in turns acts as an explanans explaining the other information object surrogate at the bottom right. One can say that the information object surrogate in the middle is holding a “*dual role*” in this relation i.e. it is two relations with the one in the middle participating in both, first as an explanandum for the information object surrogate in the bottom left and an explanans for the information object surrogate at the bottom right. The temporal order at which the events occurred helps us to answer the question of which information object surrogate is explaining which. Although the date of publication (date element) of the information object surrogate on the left is not provided in the representation, but if one refers back to the actual information object, it was published in April 18 i.e. before May 15 and the information object surrogate at the middle was reported before the other information object surrogate reported May 19.

One might ask what the difference between this example and a *timeline* relation is as they are both chronologically sorted. In an easy way, the *timeline* relation shows the entire events in the data set however, this example shows an explanatory chain consisting of explanation pairs.

## Chapter 5 Post hoc exploratory analysis

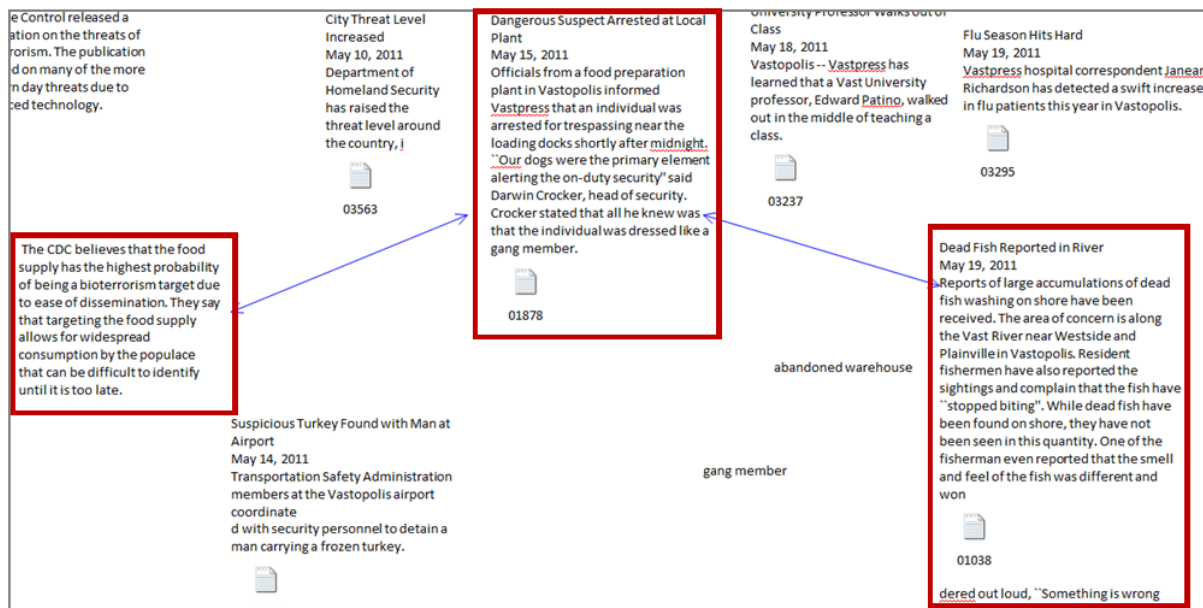

Figure 5-29: Explanation relation with three information object surrogates created by participant 3

### 5.3.1.3.5 Justification relation

A justification relation is a combination of a *claim or imperative* and its *evidential support* (see table 5-14). The *justification* relation allows the user to express a claim and provide support to increase the belief in the claim i.e. to show the argumentational support for a claim.

<b>Justification relation</b>
-------------------------------

Claim <i>mandatory element</i>
--------------------------------

Evidential support <i>mandatory element</i>
---

Table 5-14: Justification relation and elements

#### *Justification elements*

##### Claim element

A *claim* is a statement or proportion. The claim allows the users to document their thinking or inference.

##### Evidential support element

An *evidential support* is a visible representation of the information object. For example the document icon or a text string with the document identification number (e.g. 03040) or a combination of both. It allows the user to provide an evidential support to their claim in order to support their belief or validate their claim.

#### *Examples of justification relation*

The *justification* relation occurs in various ways. Figure 5-30 shows an example of the justification relation which was created by participant 14. Here, the user is answering the question “*who the potential terrorist were*” which is one of the questions they were asked to answer in their task. The user creates these by (1) producing (clicking on the representation interface and typing) a claim “[the most likely terrorist group involved is the] Anarchists for Freeform”. The Anarchists for Freeform is one of the terrorist groups mentioned in the data set (2) the user associated their claim with an arrow to an evidential support which provides evidence to support their thinking. This is done by dragging an information object from the search tool into the representation interface. The information object used by the participant mentions their choice (Anarchists for Freeform) as a threat (see figure 5-31).

## Chapter 5 Post hoc exploratory analysis



Figure 5-30: Justification relation with a claim and evidential support created by participant 14

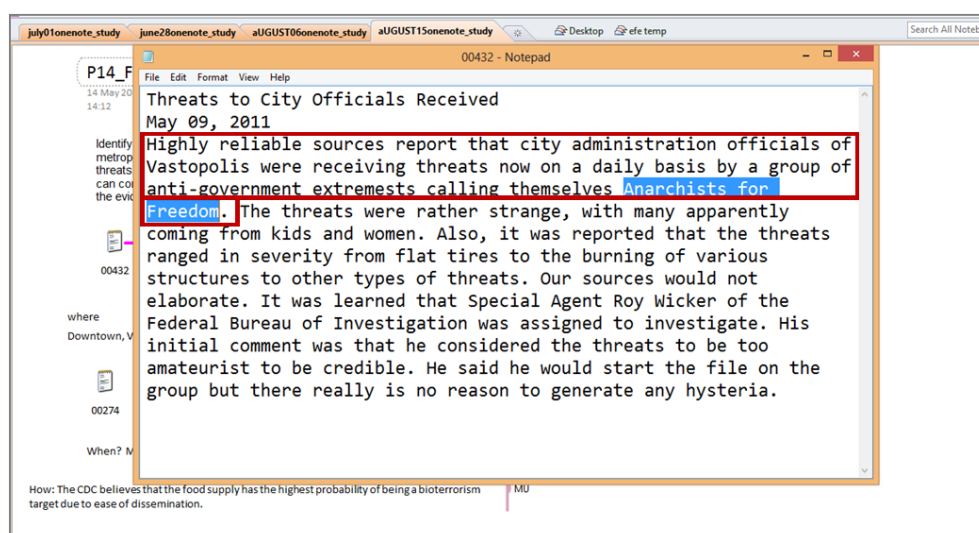

Figure 5-31: Sample of the information object's content used by participant 14 to justify their claim

Figure 5-32 shows another example of the justification relation which was also created by participant 14. Here, the user is answering the question of where the threat is likely to occur which also is part of the questions they were asked to answer. The user starts by (1) producing a claim “[the locations where the threat is likely to occur is] Downtown, Vastopolis, Airport, Local plant, farm”. (2) Then they dragged multiple information objects from the search tool to represent their evidential support. Each information object refers to these place names giving reasons to believe that these are locations for possible threat.



## Chapter 5 Post hoc exploratory analysis

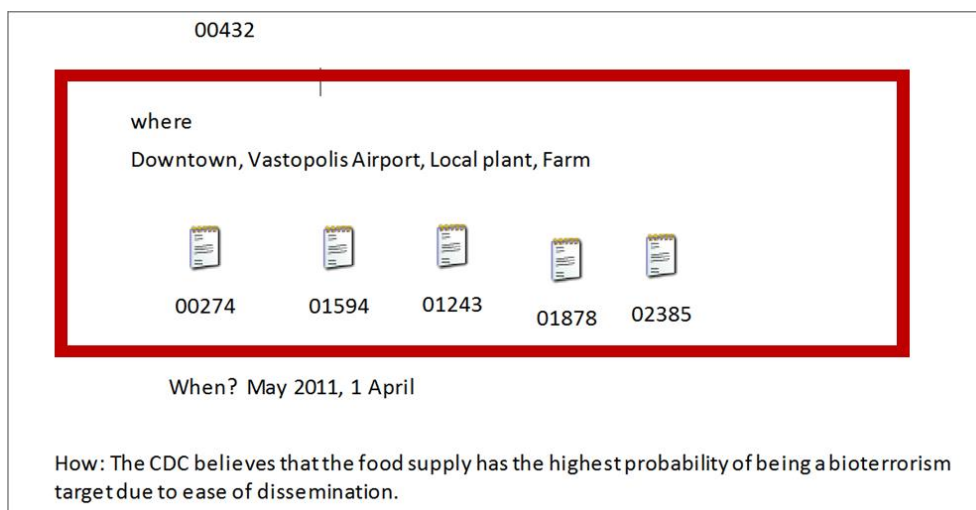

Figure 5-32: Justification relation with single claim and multiple evidential support created by participant 14

For example the participant mentioned “Airport” as a likely location and one of the information objects they used as their evidential support (document 01243) refers to the location as under possible threat (see figure 5-33)

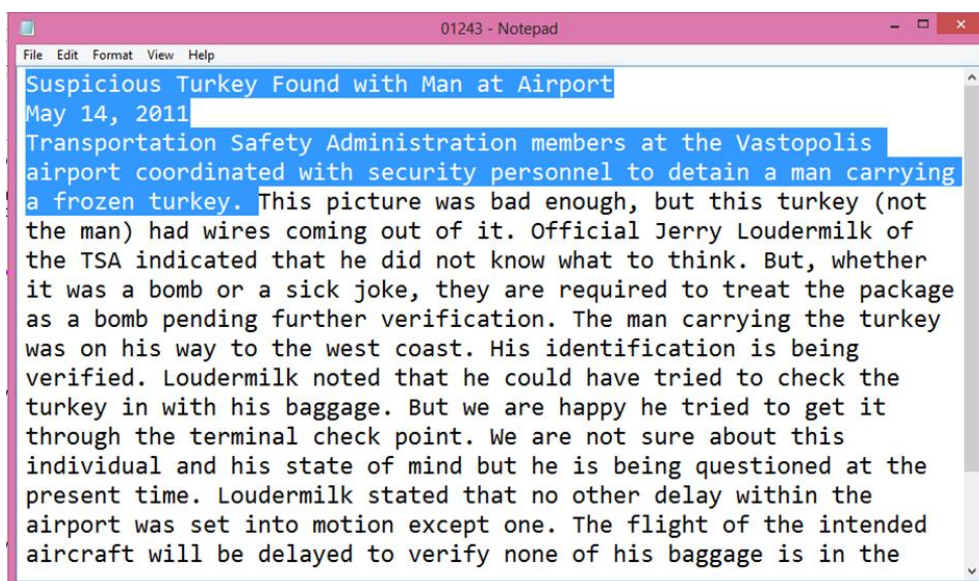

Figure 5-33: Sample information object used by participant 14 to provide support to their claim

Other justification relation examples with (1) imperative and evidential support and (2) claim and timeline combinations can be found in appendix E.

### 5.3.1.4 Relations and frequency of use

The relations are later counted and represented in a table to determine the frequency of their usage in the representations analysed.

<b>Relation</b>	<b>List of participants that used it (Out of 11)</b>	<b>Percentage (Out of 100 %)</b>
<b>Information object surrogate</b>	3, 5, 7, 9, 14, 16, 18, 20 , 24, 25, 29	100
<b>Timeline</b>	3, 7, 9, 14, 20, 25	55
<b>Themed group</b>	7, 9	18
<b>Explanation</b>	3	9
<b>Justification</b>	14, 18, 20 , 29	36

Table 5-15: The relation frequency among participants

Table 5-15 shows the frequency the ERST relations were used by the participants. Just like the activity timeline grid in the previous section, only an instance of the relation in each representation was counted. They were later used to determine a count percentage for their occurrence. The table indicates that (1) all the freeform participants used the information object surrogate relation (2) a majority of the embedded representational structuring done in the freeform condition was the timeline relation (55%). However we can also observe a good presence of the justification relation (36%) and some presence of the explanation (18%) and themed grouping (9%) relations. This observation is similar to the results we obtained while describing the average percentage time for performing structural activities on the freeform condition (Refer to section 5.2.2.2). This also expresses how much users wants to create these relations in their representation i.e. shows the relations they consider most useful and least useful in this context.

# Chapter 6

## Discussion and Conclusion

## Discussion and conclusion

### 6.1 Result summary and explanation

The outcome of the study to explore the effects that different types of representational structuring (argumentation, timeline and freeform) have on performance and user experience during intelligence type investigations indicated that the difference in user performance across conditions were not significant. On face value, this indicates that timeline representation did not offer an advantage in terms of user performance in relation to the argumentation representation. However, we noted that participants in the timeline and argumentation conditions deviated from their constrictions and constructed heterogeneous representations (figure 5.3). This we can explain might be because participants in the timeline and argumentation conditions were told to conduct their investigations using timeline and argumentation representations respectively however; they were not constricted to do so. There is room for a type  $\text{II}$  error i.e. saying that there is no significant differences when there might be one (Campbell, 2013).

However, the outcome of the study indicates that there was a significant difference of cognitive load across conditions. We found that (1) participants in the timeline condition experienced lower cognitive load compared to the participants in the argumentation condition. Pennington & Hastie (1986, 1988, 1992) stated that people structure court room evidence in narrative form. We assume that cognitive load will be lower when users are using methods which are natural to them. (2) The results also showed that the participants in the freeform condition experienced lower cognitive load than those participants in the argumentation condition. This could be explained by figure 5.3. Figure 5.3 allows us to assume that the freeform condition contains a prominent percentage of timeline structural activities. This we assume was a more natural way of performing sensemaking. (3) There was no significant difference of cognitive load on freeform and timeline. This might be because the freeform and timeline conditions have a near equal proportion of timeline structuring in their average percentage time for performing structural activities (see section 5.2.2.2). In other words, cognitive load may directly co-vary with the proportion of timeline structuring and also may inversely co-vary with the proportion of argumentation structuring.

Bex et al. (2010) stated that sometimes (in some aspects of a sensemaking task), the argumentation approach is the most natural approach for sensemaking. This explains figure 5.3 that shows a heterogeneous representation in the freeform approach. We can infer that when the freeform participants found timeline structuring as more natural, they used timeline

and when they found the argumentation approach as more natural, they used the argumentation approach.

## 6.2 Embedded Representational Structure Theory (ERST)

When creating external representations to support investigatory sensemaking, these representations tend towards embedded, heterogeneous forms. The representational 'language' evolves in emergent, ad-hoc ways, becoming more sophisticated over time. We assume that the chosen forms and their implementations depend on users- considerations of cognitive task needs and characteristics of available tools. User-generated representations can be described in terms of constituent structures. The Embedded Representational Structure Theory (ERST) offers a developing approach to capture this. ERST may offer an approach for systematically considering design alternatives for sensemaking tools and also analysing user generated representations.

By analysing user generated representations, this can enable systematic comparisons to be made between representations that are created under different independent variable conditions, for example, task, source data, participants, and interface tools. Comparisons can be made in terms of the kinds of relational structures that users create or metrics associated with creating similar relational structures, such as those relating to usability or user-experience.

Also, ERST may inform the design of sensemaking tools. The specification of interface tools both in terms of the range of relational structures supported, and the specific means by which they are realised may be identified.

However, there may be some limitations with respect to generalisation. ERST has only been used in one study which makes it nearly impossible for generalisation. However, this leads us to ways it can be expanded. Future studies can be conducted using a variety of tasks, source data, participants and interface tools. This will provide ways the theory could be expanded and also show how applicable the theory is.

### 6.2.1 Design suggestions

From the post hoc analysis sections, we have come to understand that users do what they do for a reason. Given a sensemaking problem and some tool to help solve it, they will use the tools in a way that supposedly supports their cognition. They will, presumably, also consider what they do in terms of the costs (time or cognition) it takes to do it but, what they do reflects their needs. So by understanding what they do, we are in a better position to understand their needs and therefore to design for them.

From the study, design requirements can be suggested to support these kinds of task. The requirements that can be suggested are; (1) sensemaking tools that support these kinds of task should allow for the various variations of approaches a user can take with various relations. This may save the time it takes to create the individual relations. (2) Sensemaking tools that support these kinds of task should allow for a design tool kit that consists of a composition of design languages (such as Information object surrogate, justification, timeline, theme grouping and explanation relations) that a user can simply drag and drop instead of creating them individually. For example, in design applications such as Autodesk Homestyler, a free home design software where instead of constructing a chair, a user can easily drag and drop an 'already constructed' chair into the visual canvas. In this case, the user can for example drag a justification block into the visual canvas instead of creating a claim, evidence and creating an association between them. (3) Sensemaking tools that support these kinds of task may consider automatically turning the information objects into *information object surrogates* and placing them into a *timeline* relation.

## 6.3 Study limitations

The following are the limitations of the study;

1. A possible criticism of the study as a means for testing the hypothesis is that participants in the timeline and argumentation conditions were asked to construct their representations using timeline and argumentation representations but were not constricted to do so. Future research should take greater care to ensure that the participants in the constricted conditions are adequately constricted to their conditions, which might have a significant effect on their performance and user experience.

2. Another criticism of the study was the number of participants used for the study. Future research should take greater care to allow for more participants in each condition. This might also have a significant effect on the results acquired for performance and user experience

### 6.4 Conclusion

In conclusion, the results of the study suggested that: (a) users experience lower cognitive load when they are free to structure information as they wish, (b) during their investigation they create complex heterogeneous representations consisting of various entities and multiple relation types and (c) their structuring activities can be described by a finite set of embedded structuring conventions. In order to explore and analyse the embedding of structural conventions within a single representation, the ERST was developed. ERST provides an abstraction of a representation which therefore supports the analyst and interface designer in considering representational sub-element independently in terms of important factors such as the user-costs associated with creating them and their associated cognitive affordances.





## Bibliography

- Attfield, S. (2005). *Information seeking, gathering and review: Journalism as a case study for the design of search and authoring systems* (Ph.D). University of London, United Kingdom.
- Attfield, S., & Blandford, A. (2011). Making sense of digital footprints in team-based legal investigations. *Human computer interaction*. Retrieved October 15, 2012, from <http://eprints.mdx.ac.uk/6792/>
- Baber, C., Attfield, S., Wong, W., & Rooney, C. (2013). Exploring sensemaking through an Intelligence Analysis exercise. In H. Chaudet, L. Pellegrin, N. Bonnardel, H. Chaudet, L. Pellegrin, & N. Bonnardel (Eds.), *Proceedings of the 11th International Conference on Naturalistic Decision Making* (pp. 125–131). Paris: Arpege Science Publishing. Retrieved from <http://www.ndm11.org/proceedings/papers/ndm11-125.pdf>
- Bex, F. (2009). *Evidence for a good story: a hybrid theory of arguments, stories and criminal evidence* (Doctoral dissertation). Faculty of Law, University of Groningen, Netherlands. Retrieved from <http://dissertations.ub.rug.nl/faculties/jur/2009/f.j.bex/>
- Bex, F. (2010, April). Argument Mapping and Storytelling in Criminal Cases. *Legal Information Institute*. Retrieved October 22, 2012, from <http://blog.law.cornell.edu/voxpath/2010/04/16/argument-mapping-and-storytelling-in-criminal-cases/>
- Bex, F., van Koppen, P., Prakken, H., & Verheij, B. (2010). A hybrid formal theory of arguments, stories and criminal evidence. *Artificial Intelligence and Law*, 18(2), 123–152. doi:10.1007/s10506-010-9092-x
- Blanco, R., & Silvestri, F. (2008). Efficiency Issues in Information Retrieval Workshop. In C. Macdonald, I. Ounis, V. Plachouras, I. Ruthven, & R. W. White (Eds.), *Advances in*

## Bibliography

- Information Retrieval* (pp. 711–711). Springer Berlin Heidelberg. Retrieved from [http://ecir2008.dcs.gla.ac.uk/t\\_w\\_pdf/w2.pdf](http://ecir2008.dcs.gla.ac.uk/t_w_pdf/w2.pdf)
- Block, R. A., Hancock, P. A., & Zakay, D. (2010). How cognitive load affects duration judgments: A meta-analytic review. *Acta psychologica*, *134*(3), 330–343. doi:10.1016/j.actpsy.2010.03.006
- Block, R. A., & Zakay, D. (1997). Prospective and retrospective duration judgments: A meta-analytic review. *Psychonomic Bulletin & Review*, *4*(2), 184–197. doi:10.3758/BF03209393
- Brassil, D., Hogan, C., & Attfield, S. (2009). The centrality of user modeling to high recall with high precision search. In *IEEE International Conference on Systems, Man and Cybernetics, 2009. SMC 2009* (pp. 91 –96). doi:10.1109/ICSMC.2009.5346738
- Bruin, J. (2011). Central limit theorem. *UCLA: Statistical Consulting Group*. Retrieved July 3, 2013, from <http://www.ats.ucla.edu/stat/stata/ado/teach/clt.htm>
- Calloway, J. (2013). Commentary: Predictive coding in e-discovery inescapable. *Massachusetts Lawyers Weekly*.
- Campbell, R. B. (2013). Type I and II error. *University of Northern Iowa*. Academic. Retrieved November 11, 2013, from <http://www.cs.uni.edu/~campbell/stat/inf5.html>
- Chalamish, M., Gabbay, D., & Schild, U. (2011). Intelligent evaluation of evidence using Wigmore diagrams. In *Proceedings of the 13th International Conference on Artificial Intelligence and Law* (pp. 61–65). New York, NY, USA: ACM. doi:10.1145/2018358.2018366
- Chapin, L., Attfield, S., & Okoro, E. M. (2013). Predictive Coding, Storytelling and God: Narrative Understanding in e-Discovery. Presented at the DESI V Workshop, Consiglio Nazionale delle Ricerche, Rome, Italy. Retrieved from <http://www.umiacs.umd.edu/~oard/desi5/Chapin-final.pdf>
- Chatman, S. (1980). *Story and Discourse: Narrative Structure in Fiction and Film*. Cornell University Press.

## Bibliography

- Cyra, L., & Górski, J. (2011). Support for argument structures review and assessment. *Reliability Engineering & System Safety*, 96(1), 26–37. doi:10.1016/j.ress.2010.06.027
- D'Agostino, R. B., & Stephens, M. A. (1986). *Goodness-of-fit Techniques*. M. Dekker.
- Dancey, C. P., & Reidy, J. (2011). *Statistics without maths for psychology*. Harlow, England; New York: Prentice Hall/Pearson.
- Davies, G., Lloyd-Bostock, S., McMurrin, M., & Wilson, C. (1996). *Psychology, Law, and Criminal Justice: International Developments in Research and Practice*. Walter de Gruyter.
- Eisenbach, M., & Eisenbach, A. (2003). *phpSyntaxTree*. Retrieved from <http://ironcreek.net/phpsyntaxtree/>
- Field, A., & Hole, D. G. J. (2003). *How to Design and Report Experiments*. Sage Publications Ltd.
- Fisher, A. (2004). *The logic of real arguments*. New York: Cambridge University Press.
- Gass, R. (2009). Toulmin Model of Argument. *California State University Fullerton Academic*. Retrieved November 14, 2013, from <http://commfaculty.fullerton.edu/rgass/toulmin2.htm>
- Goodwin, J., & Fisher, A. (2000). Wigmore's Chart Method. *Informal Logic*, 20(3). Retrieved from [http://ojs.uwindsor.ca/ojs/leddy/index.php/informal\\_logic/article/view/2278](http://ojs.uwindsor.ca/ojs/leddy/index.php/informal_logic/article/view/2278)
- Greitzer, F. L. (2005). Toward the development of cognitive task difficulty metrics to support intelligence analysis research. In *Fourth IEEE Conference on Cognitive Informatics, 2005. (ICCI 2005)* (pp. 315–320). doi:10.1109/COGINF.2005.1532647
- Hamilton, W. F., & Chapin, L. C. (2012). Storytelling: The Shared Quest For Excellence in Document Review. *e-Discovery Team*. Retrieved October 15, 2012, from <http://e-discoveryteam.com/2012/01/08/storytelling-the-shared-quest-for-excellence-in-document-review/>
- Harris, P. (2008). *Designing and Reporting Experiments in Psychology* (3rd ed.). Open University Press.

## Bibliography

- Hastie, R., Penrod, S. D., & Pennington, R. H. S. P. N. (1983). *Inside the Jury*. The Lawbook Exchange, Ltd.
- Healey, C. G., & Enns, J. T. (2012). Attention and Visual Memory in Visualization and Computer Graphics. *IEEE Transactions on Visualization and Computer Graphics*, 18(7), 1170–1188. doi:10.1109/TVCG.2011.127
- Hertzum, M., & Holmegaard, K. D. (2013). Perceived Time as a Measure of Mental Workload: Effects of Time Constraints and Task Success. *International Journal of Human-Computer Interaction*, 29(1), 26–39. doi:10.1080/10447318.2012.676538
- Heuer, R. J. (1999). *Psychology of Intelligence Analysis*. Lulu.com. Retrieved from [http://vadi.cc.gatech.edu/documents/5\\_Heuer,%20Jr.\\_Psych\\_of\\_Intel\\_Analy\\_CIA\\_-\\_Heuer.pdf](http://vadi.cc.gatech.edu/documents/5_Heuer,%20Jr._Psych_of_Intel_Analy_CIA_-_Heuer.pdf)
- IBM Corporation. (2007, December). Summary Graph: Total Precision vs. Recall. *IBM*. concept. Retrieved July 10, 2013, from [http://publib.boulder.ibm.com/infocenter/classify/v8r5/topic/com.ibm.classify.workbench.doc/c\\_WBG\\_Summary\\_Graph\\_Total\\_Precision\\_vs\\_Recall.htm](http://publib.boulder.ibm.com/infocenter/classify/v8r5/topic/com.ibm.classify.workbench.doc/c_WBG_Summary_Graph_Total_Precision_vs_Recall.htm)
- IEEE VAST. (2011a). Solutions. *IEEE VAST Challenge 2011*. Retrieved February 28, 2013, from <http://hcil.cs.umd.edu/localphp/hcil/vast11/index.php/solution/index>
- IEEE VAST. (2011b). Task Description. *IEEE VAST Challenge*. Retrieved February 28, 2013, from <http://hcil.cs.umd.edu/localphp/hcil/vast11/index.php/taskdesc/index>
- Kirsh, D. (2009). Interaction, External Representation and Sense Making. In *Proceedings of the Thirty-First Annual Conference of the Cognitive Science Society*. Mahwah, NJ.
- Kirsh, D., & Maglio, P. (1994). On Distinguishing Epistemic from Pragmatic Action. *Cognitive Science*, 18(4), 513–549. doi:10.1207/s15516709cog1804\_1
- Klein, G., Phillips, J. K., & Peluso, D. A. (2007). A Data-Frame Theory of Sensemaking. *Expertise Out of Context: Proceedings of the Sixth International Conference on Naturalistic Decision Making*.

## Bibliography

- Klein, Gary, Moon, B., & Hoffman, R. R. (2006). Making Sense of Sensemaking 2: A Macrocognitive Model. *IEEE Intelligent Systems*, 21(5), 88–92. doi:10.1109/MIS.2006.100
- Klingberg, T. (2000). Limitations in information processing in the human brain: neuroimaging of dual task performance and working memory tasks. *Progress in brain research*, 126, 95–102. doi:10.1016/S0079-6123(00)26009-3
- Koji, Y. (2013). Kruskal-Wallis and Friedman test. *Statistics for HCI Research*. Academic. Retrieved August 29, 2013, from <http://yatani.jp/HCIstats/KruskalWallis#EffectSize>
- Le, N.-T., Niebuhr, S., Drexler, D., & Pinkwart, N. (2013). Scaffolding Computer Supported Argumentation Processes through Mini Map Based Interaction Techniques. In A. Marcus (Ed.), *Design, User Experience, and Usability. Web, Mobile, and Product Design* (pp. 533–542). Springer Berlin Heidelberg. Retrieved from [http://link.springer.com/chapter/10.1007/978-3-642-39253-5\\_59](http://link.springer.com/chapter/10.1007/978-3-642-39253-5_59)
- Macagno, F., Reed, C., & Walton, D. (2007). *Argument Diagramming in Logic, Artificial Intelligence, and Law* (SSRN Scholarly Paper No. ID 1751655). Rochester, NY: Social Science Research Network. Retrieved from <http://papers.ssrn.com/abstract=1751655>
- McDonald, J. H. (2009). Handbook of Biological Statistics: Kruskal–Wallis test and Mann-Whitney U test. *University of Delaware*. Academic. Retrieved September 27, 2013, from <http://udel.edu/~mcdonald/statkruskalwallis.html>
- McElhaney, J. (2009, July 1). The Arsenal of Persuasion. *ABA Journal*. Retrieved from [http://www.abajournal.com/magazine/article/the\\_arsenal\\_of\\_persuasion/](http://www.abajournal.com/magazine/article/the_arsenal_of_persuasion/)
- Miller, G. A. (1956). The magical number seven, plus or minus two: some limits on our capacity for processing information. *Psychological Review*, 63(2), 81–97. doi:10.1037/h0043158
- Naugle, D. (1999, February 5). Narrative and Life: The Central Role of Stories in Human Experience. Retrieved from [http://www3.dbu.edu/naugle/pdf/narrative\\_and\\_life.pdf](http://www3.dbu.edu/naugle/pdf/narrative_and_life.pdf)
- Norman, D. A. (2002). *The Design of Everyday Things*. Basic Books.

## Bibliography

- O'Brien, H. L. (2010). The User Engagement Scale.
- O'Brien, H. L., & Toms, E. G. (2010). The development and evaluation of a survey to measure user engagement. *Journal of the American Society for Information Science and Technology*, 61(1), 50–69. doi:10.1002/asi.21229
- Pennington, N., & Hastie, R. (1986). Evidence evaluation in complex decision making. *Journal of Personality and Social Psychology*, 51(2), 242–258. doi:10.1037/0022-3514.51.2.242
- Pennington, N., & Hastie, R. (1988). Explanation-based decision making: Effects of memory structure on judgment. *Journal of Experimental Psychology: Learning, Memory, and Cognition*, 14(3), 521–533. doi:10.1037/0278-7393.14.3.521
- Pennington, N., & Hastie, R. (1991). Cognitive Theory of Juror Decision Making: The Story Model. *Cardozo Law Review*, 13, 519.
- Pennington, N., & Hastie, R. (1992). Explaining the evidence: Tests of the Story Model for juror decision making. *Journal of Personality and Social Psychology*, 62(2), 189–206. doi:10.1037/0022-3514.62.2.189
- Pennington, N., & Hastie, R. (n.d.). ATTITUDES AND SOCIAL COGNITION Explaining the Evidence: Tests of the Story Model for Juror Decision Making. Retrieved from <http://130.203.133.150/viewdoc/summary?jsessionid=AEE219CAE5DF031511D6967288798BF8?doi=10.1.1.189.4882>
- Pirolli, P., & Card, S. (2005). The sensemaking process and leverage points for analyst technology as identified through cognitive task analysis. In *Proceedings of International Conference on Intelligence Analysis* (Vol. 2005, pp. 2–4).
- Ramsey, N. F., Jansma, J. M., Jager, G., Raalten, T. V., & Kahn, R. S. (2004). Neurophysiological factors in human information processing capacity. *Brain*, 127(3), 517–525. doi:10.1093/brain/awh060
- Reed, C. (2007). wigmore, toulmin and walton: the diagramming trinity and their application in legal practice. In *Graphic and Visual Representations of Evidence and Inference in Legal Settings*. Cardozo Law School, New York.

## Bibliography

- Rijsbergen, C. J. van. (1981). Retrieval effectiveness. In *Information retrieval experiment* (pp. 32–43). Butterworths.
- Rijsbergen, C. J. van. (1979). *Information retrieval*. Butterworth-Heinemann. Retrieved from <http://www.dcs.gla.ac.uk/Keith/Preface.html>
- Rowe, G., & Reed, C. (2006). Translating Wigmore Diagrams. In *Proceedings of the 2006 conference on Computational Models of Argument: Proceedings of COMMA 2006* (pp. 171–182). Amsterdam, The Netherlands, The Netherlands: IOS Press. Retrieved from <http://dl.acm.org/citation.cfm?id=1565233.1565254>
- Russell, D. M., Stefik, M. J., Pirolli, P., & Card, S. K. (1993). The cost structure of sensemaking. In *Proceedings of the INTERACT '93 and CHI '93 Conference on Human Factors in Computing Systems* (pp. 269–276). New York, NY, USA: ACM. doi:10.1145/169059.169209
- Sbarski, P., van Gelder, T., Marriott, K., Prager, D., & Bulka, A. (2008). Visualizing Argument Structure. In G. Bebis, R. Boyle, B. Parvin, D. Koracin, P. Remagnino, F. Porikli, ... L. Monroe (Eds.), *Advances in Visual Computing* (pp. 129–138). Springer Berlin Heidelberg. Retrieved from [http://link.springer.com/chapter/10.1007/978-3-540-89639-5\\_13](http://link.springer.com/chapter/10.1007/978-3-540-89639-5_13)
- Simon, H. A., & Newell, A. (1971). Human problem solving: The state of the theory in 1970. *American Psychologist*, 26(2), 145–159. doi:10.1037/h0030806
- Simon, S., Erduran, S., & Osborne, J. (2006). Learning to Teach Argumentation: Research and development in the science classroom. *International Journal of Science Education*, 28(2-3), 235–260. doi:10.1080/09500690500336957
- Stuhldreher, T. (2012). Predictive coding cuts discovery expenses. *Central Penn Business Journal*, 28(37), 19.
- Sucala, M., Scheckner, B., & David, D. (2011). Psychological Time: Interval Length Judgments and Subjective Passage of Time Judgments. *Current psychology letters. Behaviour, brain & cognition*, (Vol. 26, Issue 2, 2010). Retrieved from <http://cpl.revues.org/index4998.html>

## Bibliography

- Teufel, S. (2006). An Overview of evaluation methods in TREC Ad-hoc Information Retrieval and TREC Question Answering. In *Evaluation of Text and Speech Systems*. Dordrecht, The Netherlands: Springer.
- The Oxford English Dictionary. (2013). Premise. *The Oxford English Dictionary*. Oxford, UK: Oxford University Press. Retrieved from <http://www.oxforddictionaries.com/definition/english/premise>
- Thomas, J. J., & Cook, K. A. (Eds.). (2005). *Illuminating the Path: The Research and Development Agenda for Visual Analytics*. National Visualization and Analytics Ctr.
- Toulmin, S. E., Rieke, R. D., & Janik, A. (1979). *An Introduction to reasoning*. New York [etc.]: Macmillan.
- Twardy, D. C. R. (2003). Argument Maps Improve Critical Thinking. Preprint. Retrieved September 17, 2013, from <http://cogprints.org/3008/>
- United States Joint Chiefs of Staff. (2007). *Joint Intelligence*. Retrieved from [http://www.dtic.mil/doctrine/new\\_pubs/jp2\\_0.pdf](http://www.dtic.mil/doctrine/new_pubs/jp2_0.pdf)
- Van den Braak, S. W., Vreeswijk, G. A. W., & Prakken, H. (2007). AVERs: an argument visualization tool for representing stories about evidence. In *Proceedings of the 11th international conference on Artificial intelligence and law* (pp. 11–15). New York, NY, USA: ACM. doi:10.1145/1276318.1276321
- Van Gelder, T. (2002). Argument mapping with reason!able. *The American Philosophical Association Newsletter on Philosophy and Computers*, 2(1), 85–90.
- Van Gelder, T. (2009, February 17). What is argument mapping? *Tim van Gelder*. Retrieved September 19, 2013, from <http://timvangelder.com/2009/02/17/what-is-argument-mapping/>
- Walker, I. (2008). Statistics for Psychology. *University of Bath*. Academic. Retrieved September 27, 2013, from <http://staff.bath.ac.uk/pssiw/stats2/page2/page3/page3.html>



## Bibliography

- Wigmore, J. H. (1913). *The principles of judicial proof as given by logic, psychology, and general experience, and illustrated in judicial trials*; Boston: Little, Brown, and company. Retrieved from <http://archive.org/details/principlesofjudi00wigm>
- Zander, C. (2009). Language grammar. *University of Washington*. Academic. Retrieved December 3, 2013, from <http://courses.washington.edu/css448/zander/Notes/langGrammar.pdf>
- Zhang, X., Qu, Y., Giles, C. L., & Song, P. (2008). CiteSense: supporting sensemaking of research literature. In *Proceedings of the twenty-sixth annual SIGCHI conference on Human factors in computing systems* (pp. 677–680). New York, NY, USA: ACM. doi:10.1145/1357054.1357161
- Zhao, Y. (2012). *R and Data Mining: Examples and Case Studies*. Academic Press, Elsevier. Retrieved from <http://www.rdatamining.com/books/rdm>

# Appendices

## Appendices

### 8.1 Appendix A: Consent form and Questionnaire

#### 8.1.1 Consent form

#### School of Science and Technology Research Consent Form

##### **NOTICE TO THE RESEARCH PARTICIPANT**

This consent form, a copy of which has been given to you (the research participant), is only part of the process of informed consent. It should give you the basic idea of what the research is about and what your participation will involve. If you would like more details about something mentioned here, or information not included here, please ask. Please take the time to read this form carefully and to understand any accompanying information.

##### **INFORMATION REGARDING THE RESEARCH PROJECT**

###### **Research Project Title:**

Effects of visual representation structures on electronic discovery type investigations.

###### **Name of Researcher:**

Efeosasere Okoro

###### **Purpose of Experiment:**

To explore how the creation of different visual representation structures affects the sense making process of legal professionals on electronic discovery type investigations in terms of relevance, certainty, the decision process and engagement.

###### **Participant Recruitment and Selection:**

Postgraduate students are been recruited for this study

###### **Procedure:**

The procedure for the study is divided into three stages; training, task and post interview

###### *Training:*

The subjects would first be given a general tour of the platform for their representation (Microsoft One Note) and also keyword searching and operations (AND, OR, IN) using Microsoft Windows Explorer. They would also be trained on a specific representation style (Narrative,

## Appendices

Argumentation or freeform) depending on the representation form they are randomly selected to do.

### *Task:*

They would be given an investigative task that requires them to perform an investigation using a data set of 30 documents and then come up with conclusions using the representations they have been trained to use.

The task is to identify any potential terrorist threat from the information in the documents.

### *Post task Interview and Questionnaire*

After the task, interviews would be conducted to gather the subject's general impressions of their experience, and to report some measures such as confidence in their conclusions and engagement in the task.

The average time taken for this study and training is 50 minutes.

### **Data Collection:**

The following data would be collected.

The screen recording of the processes of investigations

The final representation

Time taken to complete the representation.

The interview recording and,

The data provided in the questionnaire

### **Confidentiality:**

The data collected would be used specifically for the purpose of this study

### **Likelihood of Discomfort:**

There is no notable likelihood of discomfort that can arise from this study.

### **Further information about the Researcher and the Project:**

The researcher is a postgraduate Visual Analytics research student of Middlesex University. He is been supervised by Dr. Simon Attfield

### **Finding out about Results:**

If you have any interests in the outcome of the results of this study, the researcher would be more than happy if you contact them on [eo420@live.mdx.ac.uk](mailto:eo420@live.mdx.ac.uk)

## Appendices

### **AGREEMENT**

Your signature on this form indicates that you (the research participant) have understood to your satisfaction the information regarding participation in the research project and agree to participate as a participant. In no way does this waive your legal rights nor release the researcher/investigator, sponsors, or involved institutions from their legal and professional responsibilities. You are free to not answer specific items or questions in interviews or on questionnaires. You are free to withdraw from the study at any time without penalty. Your continued participation should be as informed as your initial consent, so you should feel free to ask for clarification or new information throughout your participation.

The researcher agrees to abide by the provisions of the UK Data Protection Act 1998 and all other relevant legal and ethical obligations. If you have further questions concerning matters related to this research, please contact the researcher.

\_\_\_\_\_  
**Participant**                      **Date**

\_\_\_\_\_  
**Researcher/Investigator**                      **Date**

A copy of this completed consent form will be given to you to keep for your records and reference.

This form can be downloaded from: <http://tinyurl.com/sst-ethics>

## 8.1.2 Background Information form

Age:

Gender:

Nationality:

Religion:

Are you a natural English speaker?

### **Preferences**

- **Your movie genre preferences:**
  1. 1<sup>st</sup> Preference:
  2. 2<sup>nd</sup> Preference:
  3. 3<sup>rd</sup> Preference:
- How often do you watch them?
- Your novel genre preference:
  1. 1<sup>st</sup> Preference:
  2. 2<sup>nd</sup> Preference:
  3. 3<sup>rd</sup> Preference:
- How often do you read novels?
- Have you lost anyone in any terrorist attacks?

Representation to be used:

### 8.1.3 Certainty questionnaire

P0\_\_

# Certainty Assessment

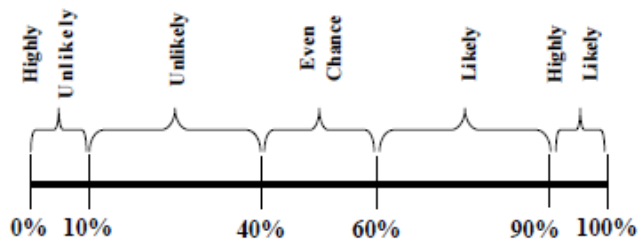

**Is there a terrorist threat?**

How confident are you that a terrorist threat is been planned (what's your confidence level)?



**What is the terrorist threat?**

How confident are you that it is what you said it is (what's your confidence level)?



**Who is involved?**

How confident are you it is that group (what's your confidence level)?



**Where is it going to happen?**

How confident are you of where it will happen (what's your confidence level)?



**When is it going to happen?**

How confident are you of when it will happen (what's your confidence level)?



**How is it going to happen?**

How confident are you of how it will happen (what's your confidence level)?



**What is your general confidence level for the information you provided?**



<b>INTELLIGENCE CONFIDENCE LEVELS</b>		
<b>Description of Probability or Confidence</b>	<b>Synonyms</b>	<b>Percent</b>
<b>HIGHLY LIKELY</b>	<ul style="list-style-type: none"> <li>◆ Highly Probable</li> <li>◆ We Are Convinced</li> <li>◆ Virtually Certain</li> <li>◆ Almost Certain</li> <li>◆ High Confidence</li> <li>◆ High Likelihood</li> </ul>	<b>&gt;90%</b>
<b>LIKELY</b>	<ul style="list-style-type: none"> <li>◆ Probable</li> <li>◆ We Estimate</li> <li>◆ Chances Are Good</li> <li>◆ High-Moderate Confidence</li> <li>◆ Greater Than 60% Likelihood</li> </ul>	<b>60-90%</b>
<b>EVEN CHANCE</b>	<ul style="list-style-type: none"> <li>◆ Chances Are Slightly Greater (or Less) Than Even</li> <li>◆ Chances Are About Even</li> <li>◆ Moderate Confidence</li> <li>◆ Possible</li> </ul>	<b>40-60%</b>
<b>UNLIKELY</b>	<ul style="list-style-type: none"> <li>◆ Probably Not</li> <li>◆ Not Likely</li> <li>◆ Improbable</li> <li>◆ We Believe ...Not</li> <li>◆ Low Confidence</li> <li>◆ Possible but Not Likely</li> </ul>	<b>10-40%</b>
<b>HIGHLY UNLIKELY</b>	<ul style="list-style-type: none"> <li>◆ Highly Improbable</li> <li>◆ Nearly Impossible</li> <li>◆ Only a Slight Chance</li> <li>◆ Highly Doubtful</li> </ul>	<b>&lt;10%</b>



## 8.1.4 Engagement questionnaire

P0\_\_

# Engagement Assessment

Strongly Disagree	Disagree	Neutral	Agree	Strongly Agree
----------------------	----------	---------	-------	-------------------

### Focused attention (FA)

I lost myself in the representation of my investigation

I was so involved in the representation that I lost track of time.

I blocked out things around me when I was doing my representations

When I was doing the representation, I lost track of the world around me

The time I spent doing my representation just slipped away

I was absorbed in my representation task

During this representation experience, I let my self go.

Strongly Disagree	Disagree	Neutral	Agree	Strongly Agree
----------------------	----------	---------	-------	-------------------

### Endurability (EN)

Doing my investigation using this representation was worthwhile

I consider my representation experience a success

Investigation using this representation did not work out as I planned

Doing my investigation using this representation was rewarding

P0\_\_

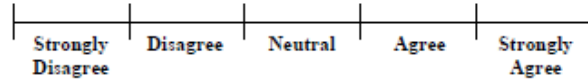

**Focused Involvement (FI)**

I was really drawn into investigating with my representation \_\_\_\_\_

I felt involved in the investigating with my representation \_\_\_\_\_

Using this representation was fun \_\_\_\_\_

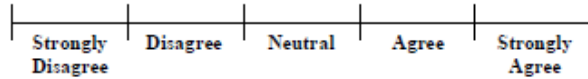

**Perceived Usability (PUs)**

I felt frustrated while doing my representation for this investigation \_\_\_\_\_

I found the representation I was asked to use confusing \_\_\_\_\_

I felt annoyed while doing my investigation using this representation \_\_\_\_\_

I felt discouraged while doing my investigations with this representation \_\_\_\_\_

Using this representation for my investigation was mentally taxing \_\_\_\_\_

Using this representation for my investigation was demanding \_\_\_\_\_

I felt in control of my investigation using this representation \_\_\_\_\_

I could not do some of the things I needed to do using this representation for my investigation \_\_\_\_\_

## 8.2 Appendix B: Study presentation slides

### 8.2.1 Argument condition presentation

# Specific Group Training

Argument Representation

## Techniques

- Search for relevant document using keywords
  - Try as much range of keywords as possible
- Review each relevant document and come up with a conclusion.
  - Support your conclusion
  - Counter them if you can
    - However, import the relevant documents as evidences

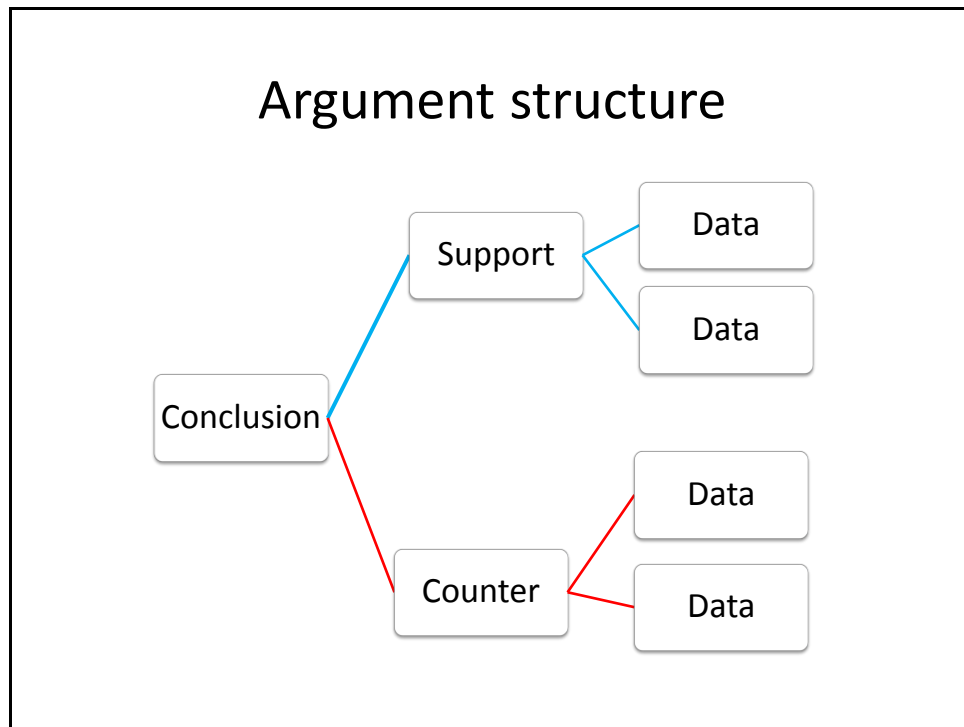

## 8.2.2 Timeline condition presentation

### Technique

- Search for relevant document using keywords
  - Try as much range of keywords as possible
- Create a timeline of events from your relevant document selection

### Specific Group Training

Timeline Representation

### 8.2.3 Freeform condition presentation

## Specific Group training

Freeform Representation

## Technique

- Use the data set you have been provide with to conduct your investigation using one note.

## 8.3 Appendix C: SPSS Output

### 8.3.1 Frequencies

**Statistics**

		ObjectiveTime	Cognitiveload	Recall	Precision	F1Measure
N	Valid	30	30	30	30	27
	Missing	0	0	0	0	3
Skewness		1.191	.627	.333	.036	-.075
Std. Error of Skewness		.427	.427	.427	.427	.448
Kurtosis		1.295	-.705	-.701	.389	-.616
Std. Error of Kurtosis		.833	.833	.833	.833	.872

**Statistics**

		Certainty	Engagment	Understanding
N	Valid	30	30	30
	Missing	0	0	0
Skewness		-.161	-.249	.662
Std. Error of Skewness		.427	.427	.427
Kurtosis		-.871	1.041	-.454
Std. Error of Kurtosis		.833	.833	.833

### 8.3.2 Histograms

#### 8.3.2.1 Objective Time Histogram

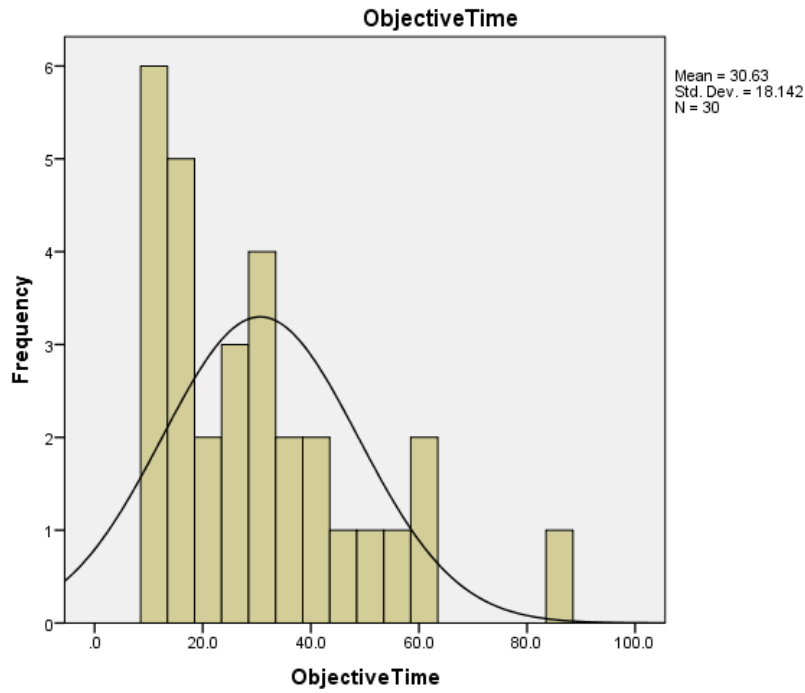

#### 8.3.2.2 Cognitive load Histogram

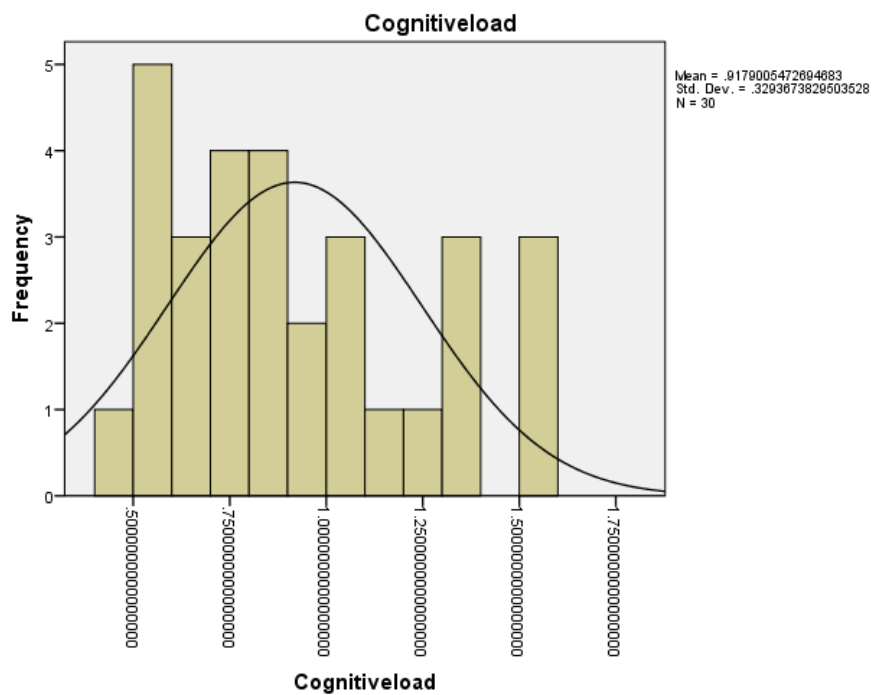



### 8.3.2.3 Recall Histogram

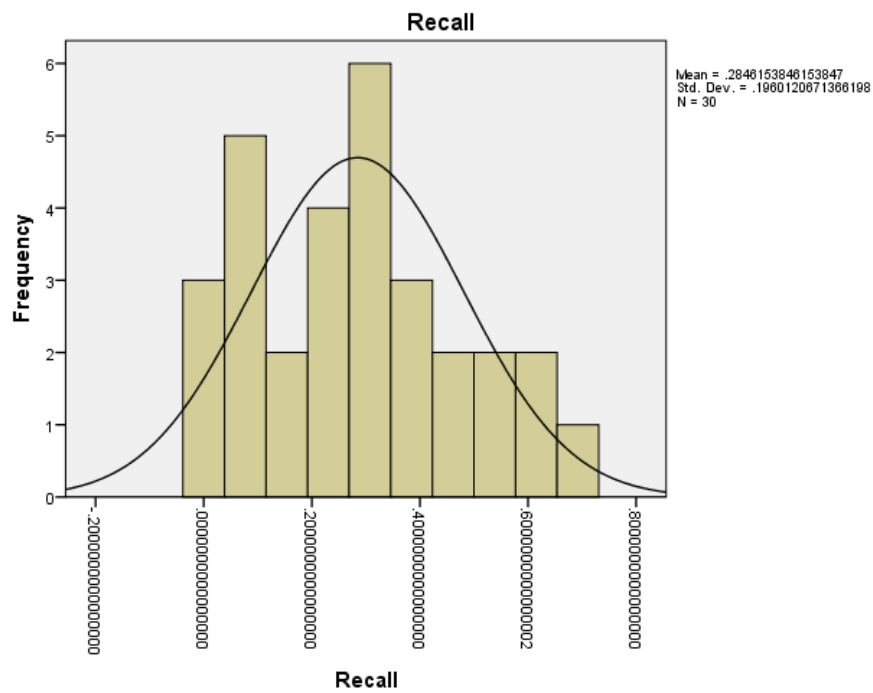

### 8.3.2.4 Precision Histogram

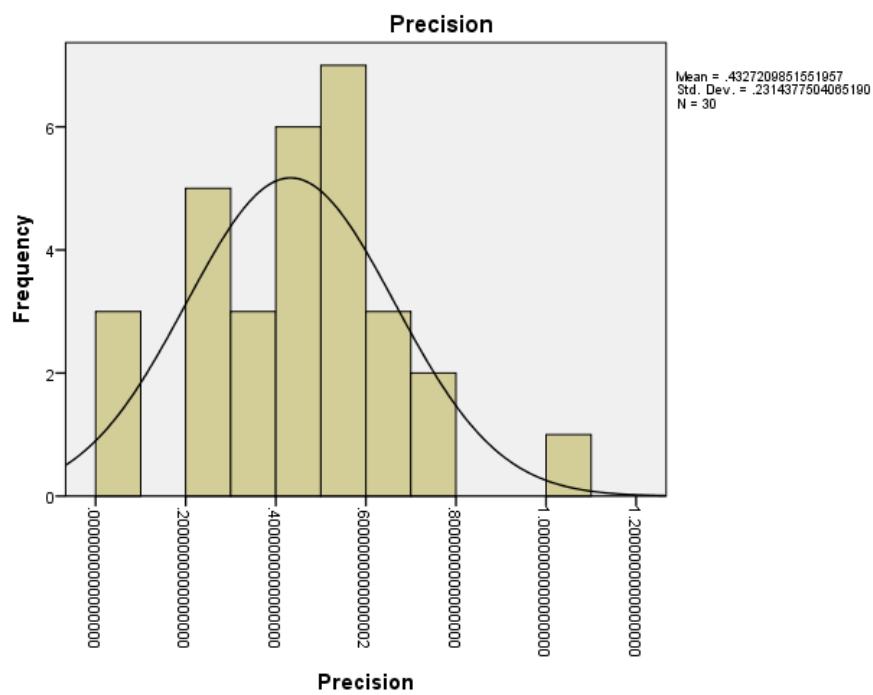

### 8.3.2.5 F1 Measure Histogram

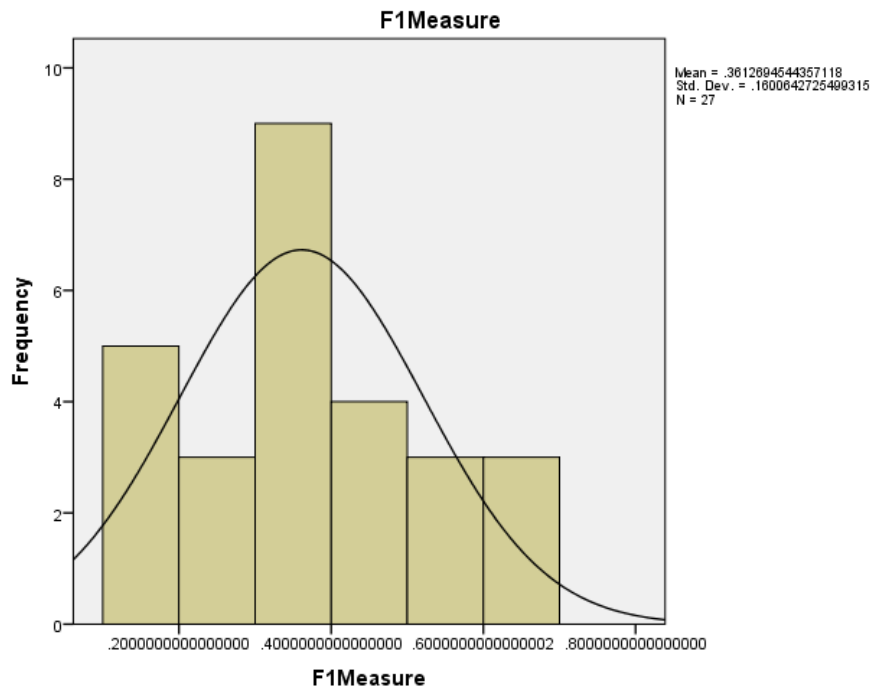

### 8.3.2.6 Confidence Histogram

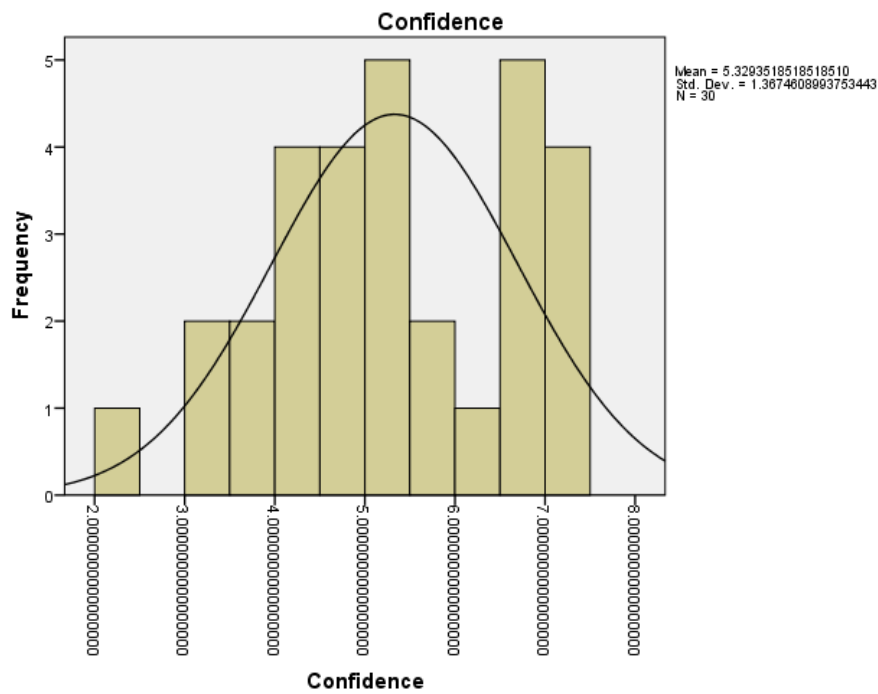

### 8.3.2.7 Engagement Histogram

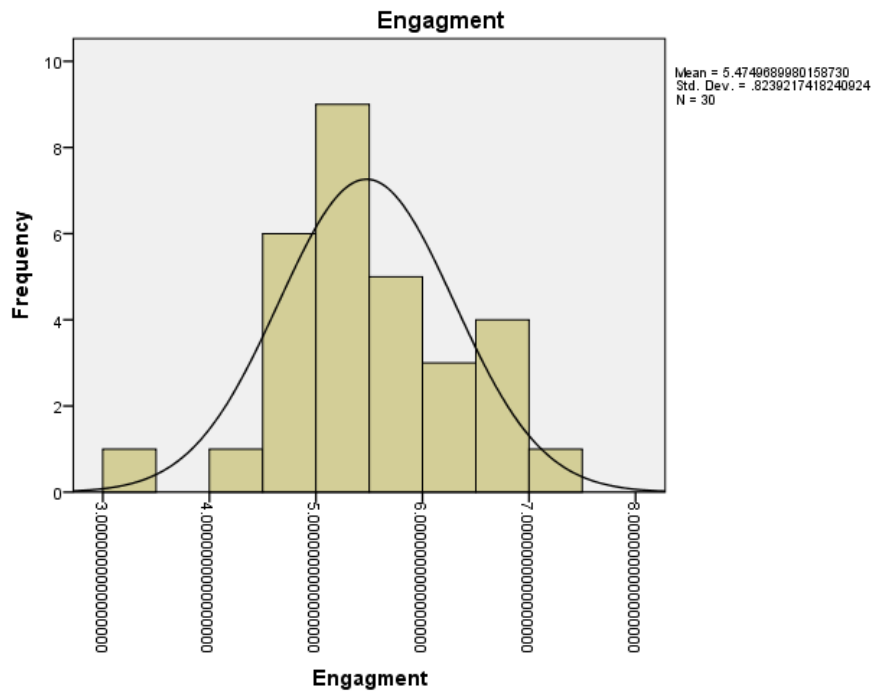

### 8.3.2.8 Understanding Histogram

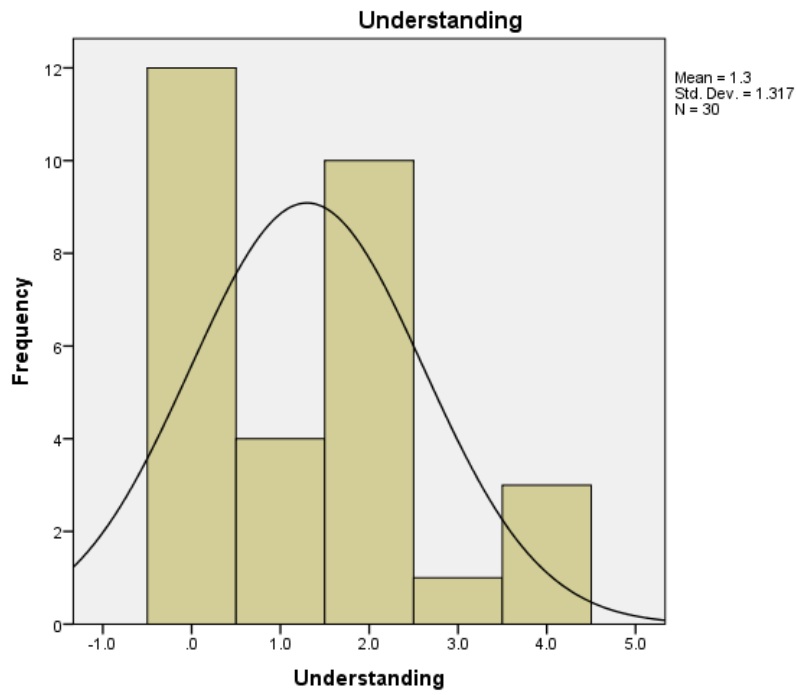

### 8.3.3 Kruskal-Wallis Test For all dependent variables

Where conditions 1.0, 2.0 and 3.0 refers argument, freeform and timeline respectively

Ranks			
	Condition	N	Mean Rank
ObjectiveTime	1.0	9	13.11
	2.0	11	17.23
	3.0	10	15.75
	Total	30	
Cognitiveload	1.0	9	21.61
	2.0	11	11.36
	3.0	10	14.55
	Total	30	
Recall	1.0	9	12.50
	2.0	11	18.23
	3.0	10	15.20
	Total	30	
Precision	1.0	9	14.44
	2.0	11	17.86
	3.0	10	13.85
	Total	30	
F1Measure	1.0	9	12.39
	2.0	11	18.64
	3.0	10	14.85
	Total	30	
Certainty	1.0	9	15.11
	2.0	11	14.00
	3.0	10	17.50
	Total	30	
Engagment	1.0	9	20.44
	2.0	11	14.45
	3.0	10	12.20
	Total	30	
Understanding	1.0	9	15.72
	2.0	11	16.14
	3.0	10	14.60
	Total	30	

## Appendices

**Test Statistics<sup>a,b</sup>**

	ObjectiveTime	<b>Cognitiveload</b>	Recall	Precision	F1Measure	Certainty
Chi-Square	1.098	<b>6.894</b>	2.149	1.281	2.583	.853
df	2	<b>2</b>	2	2	2	2
Asymp. Sig.	.578	<b>.032</b>	.341	.527	.275	.653

**Test Statistics<sup>a,b</sup>**

	Engagment	Understanding
Chi-Square	4.399	.187
df	2	2
Asymp. Sig.	.111	.911

a. Kruskal Wallis Test

b. Grouping Variable: Condition

### 8.3.4 Mann-Whitney Test for the Argument (1.0) and Freeform (2.0) conditions

<b>Ranks</b>				
	Condition	N	Mean Rank	Sum of Ranks
ObjectiveTime	1.0	9	9.22	83.00
	2.0	11	11.55	127.00
	Total	20		
Cognitiveload	1.0	9	14.00	126.00
	2.0	11	7.64	84.00
	Total	20		
Recall	1.0	9	8.44	76.00
	2.0	11	12.18	134.00
	Total	20		
Precision	1.0	9	9.78	88.00
	2.0	11	11.09	122.00
	Total	20		
F1Measure	1.0	9	8.28	74.50
	2.0	11	12.32	135.50
	Total	20		
Certainty	1.0	9	11.22	101.00
	2.0	11	9.91	109.00
	Total	20		
Engagment	1.0	9	12.89	116.00
	2.0	11	8.55	94.00
	Total	20		
Understanding	1.0	9	10.39	93.50
	2.0	11	10.59	116.50
	Total	20		

## Appendices

**Test Statistics<sup>a</sup>**

	ObjectiveTime	Cognitiveload	Recall	Precision	F1Measure
Mann-Whitney U	38.000	<b>18.000</b>	31.000	43.000	29.500
Wilcoxon W	83.000	<b>84.000</b>	76.000	88.000	74.500
Z	-.875	<b>-2.397</b>	-1.414	-.495	-1.522
Asymp. Sig. (2-tailed)	.381	<b>.017</b>	.157	.621	.128
Exact Sig. [2*(1-tailed Sig.)]	.412 <sup>b</sup>	<b>.016<sup>b</sup></b>	.175 <sup>b</sup>	.656 <sup>b</sup>	.131 <sup>b</sup>

**Test Statistics<sup>a</sup>**

	Certainty	Engagment	Understanding
Mann-Whitney U	43.000	28.000	48.500
Wilcoxon W	109.000	94.000	93.500
Z	-.494	-1.633	-.080
Asymp. Sig. (2-tailed)	.621	.102	.936
Exact Sig. [2*(1-tailed Sig.)]	.656 <sup>b</sup>	.112 <sup>b</sup>	.941 <sup>b</sup>

a. Grouping Variable: Condition

b. Not corrected for ties.

### 8.3.5 Mann-Whitney Test for Argument (1.0) and Timeline (3.0) conditions

Ranks				
	Condition	N	Mean Rank	Sum of Ranks
ObjectiveTime	1.0	9	8.89	80.00
	3.0	10	11.00	110.00
	Total	19		
Cognitiveload	1.0	9	12.61	113.50
	3.0	10	7.65	76.50
	Total	19		
Recall	1.0	9	9.06	81.50
	3.0	10	10.85	108.50
	Total	19		
Precision	1.0	9	9.67	87.00
	3.0	10	10.30	103.00
	Total	19		
F1Measure	1.0	9	9.11	82.00
	3.0	10	10.80	108.00
	Total	19		
Certainty	1.0	9	8.89	80.00
	3.0	10	11.00	110.00
	Total	19		
Engagment	1.0	9	12.56	113.00
	3.0	10	7.70	77.00
	Total	19		
Understanding	1.0	9	10.33	93.00
	3.0	10	9.70	97.00
	Total	19		



## Appendices

**Test Statistics<sup>a</sup>**

	ObjectiveTime	Cognitiveload	Recall	Precision	F1Measure
Mann-Whitney U	35.000	<b>21.500</b>	36.500	42.000	37.000
Wilcoxon W	80.000	<b>76.500</b>	81.500	87.000	82.000
Z	-.821	<b>-1.924</b>	-.703	-.246	-.655
Asymp. Sig. (2-tailed)	.412	<b>.054</b>	.482	.806	.512
Exact Sig. [2*(1-tailed Sig.)]	.447 <sup>b</sup>	<b>.053<sup>b</sup></b>	.497 <sup>b</sup>	.842 <sup>b</sup>	.549 <sup>b</sup>

**Test Statistics<sup>a</sup>**

	Certainty	Engagment	Understanding
Mann-Whitney U	35.000	22.000	42.000
Wilcoxon W	80.000	77.000	97.000
Z	-.816	-1.878	-.262
Asymp. Sig. (2-tailed)	.414	.060	.794
Exact Sig. [2*(1-tailed Sig.)]	.447 <sup>b</sup>	.065 <sup>b</sup>	.842 <sup>b</sup>

a. Grouping Variable: Condition

b. Not corrected for ties.

### 8.3.6 Mann-Whitney Test for Freeform (2.0) and Timeline (3.0) conditions

		<b>Ranks</b>		
	Condition	N	Mean Rank	Sum of Ranks
ObjectiveTime	2.0	11	11.68	128.50
	3.0	10	10.25	102.50
	Total	21		
Cognitiveload	2.0	11	9.73	107.00
	3.0	10	12.40	124.00
	Total	21		
Recall	2.0	11	12.05	132.50
	3.0	10	9.85	98.50
	Total	21		
Precision	2.0	11	12.77	140.50
	3.0	10	9.05	90.50
	Total	21		
F1Measure	2.0	11	12.32	135.50
	3.0	10	9.55	95.50
	Total	21		
Certainty	2.0	11	10.09	111.00
	3.0	10	12.00	120.00
	Total	21		
Engagment	2.0	11	11.91	131.00
	3.0	10	10.00	100.00
	Total	21		
Understanding	2.0	11	11.55	127.00
	3.0	10	10.40	104.00
	Total	21		

## Appendices

**Test Statistics<sup>a</sup>**

	ObjectiveTime	Cognitiveload	Recall	Precision	F1Measure
Mann-Whitney U	47.500	41.000	43.500	35.500	40.500
Wilcoxon W	102.500	107.000	98.500	90.500	95.500
Z	-.529	-.986	-.822	-1.382	-1.024
Asymp. Sig. (2-tailed)	.597	.324	.411	.167	.306
Exact Sig. [2*(1-tailed Sig.)]	.605 <sup>b</sup>	.349 <sup>b</sup>	.426 <sup>b</sup>	.173 <sup>b</sup>	.314 <sup>b</sup>

**Test Statistics<sup>a</sup>**

	Certainty	Engagment	Understanding
Mann-Whitney U	45.000	45.000	49.000
Wilcoxon W	111.000	100.000	104.000
Z	-.704	-.704	-.444
Asymp. Sig. (2-tailed)	.481	.481	.657
Exact Sig. [2*(1-tailed Sig.)]	.512 <sup>b</sup>	.512 <sup>b</sup>	.705 <sup>b</sup>

a. Grouping Variable: Condition

b. Not corrected for ties.

### 8.3.7 Kruskal-Wallis Test for structural activities

**Ranks**

	Condition	N	Mean Rank
Timeline	1	9	11.56
	2	11	17.09
	3	10	17.30
	Total	30	
Themegrouping	1	9	15.22
	2	11	15.00
	3	10	16.30
	Total	30	
Explanation	1	9	16.78
	2	11	15.45
	3	10	14.40
	Total	30	
Justification	1	9	19.94
	2	11	12.18
	3	10	15.15
	Total	30	

**Test Statistics<sup>a,b</sup>**

	Timeline	Themegrouping	Explanation	Justification
Chi-Square	2.796	.364	.571	4.237
df	2	2	2	2
Asymp. Sig.	.247	.834	.752	.120

a. Kruskal Wallis Test

b. Grouping Variable: Condition

### 8.3.8 Kruskal-Wallis Test for information seeking and behaviour activities

**Ranks**

	Condition	N	Mean Rank
Search	1	9	15.61
	2	11	15.18
	3	10	15.75
	Total	30	
Review	1	9	14.22
	2	11	15.27
	3	10	16.90
	Total	30	
DocumentNote	1	9	15.94
	2	11	17.14
	3	10	13.30
	Total	30	
ImportDocument	1	9	15.94
	2	11	15.05
	3	10	15.60
	Total	30	
MergeDocumentWithNote	1	9	11.83
	2	11	16.77
	3	10	17.40
	Total	30	

**Test Statistics<sup>a,b</sup>**

	Search	Review	DocumentNote	ImportDocument	MergeDocumentWithNote
Chi-Square	.024	.450	1.028	.055	2.659
df	2	2	2	2	2
Asymp. Sig.	.988	.799	.598	.973	.265

a. Kruskal Wallis Test

b. Grouping Variable: Condition

## 8.4 Appendix D: Activity timeline grids

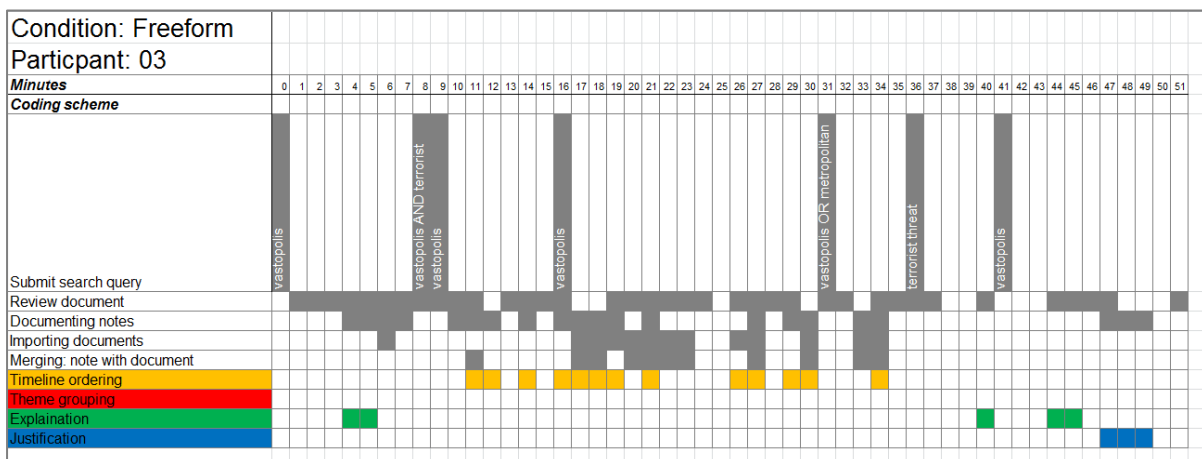
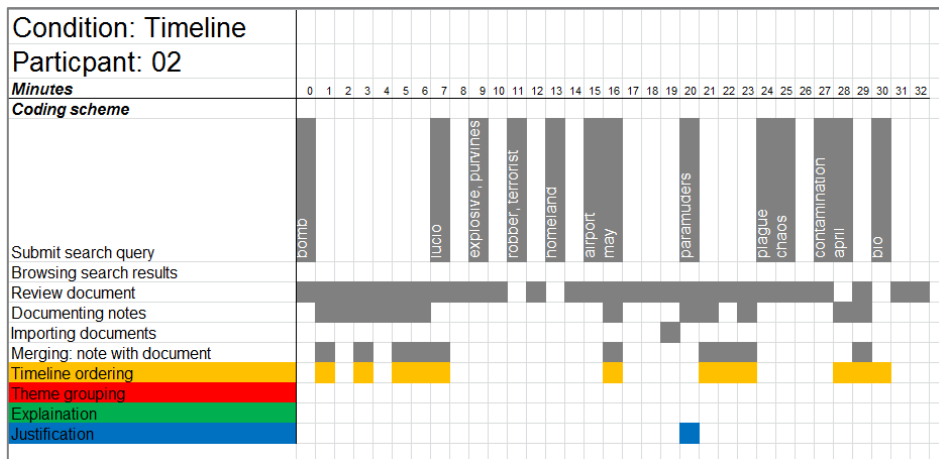
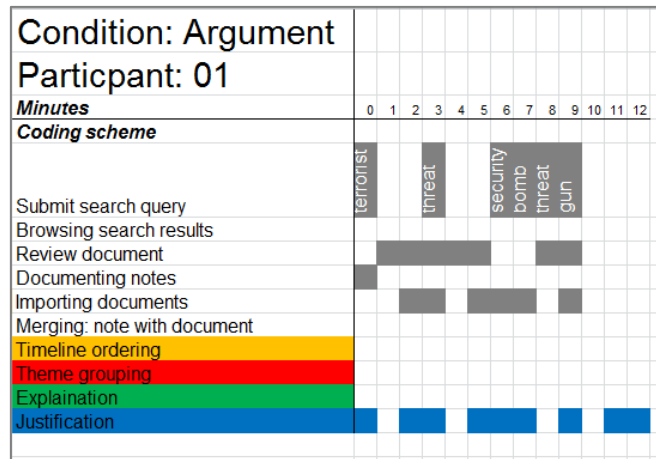

# Appendices

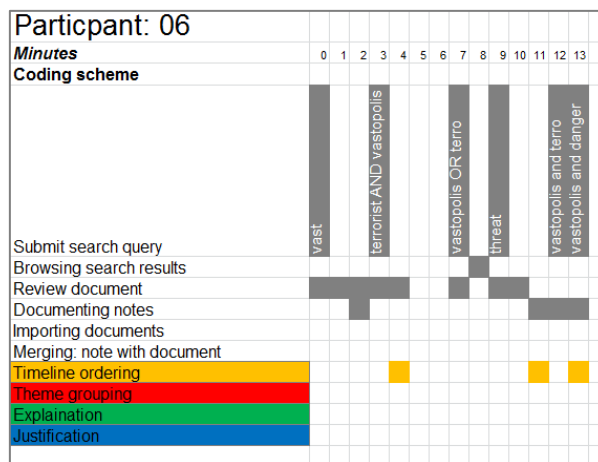
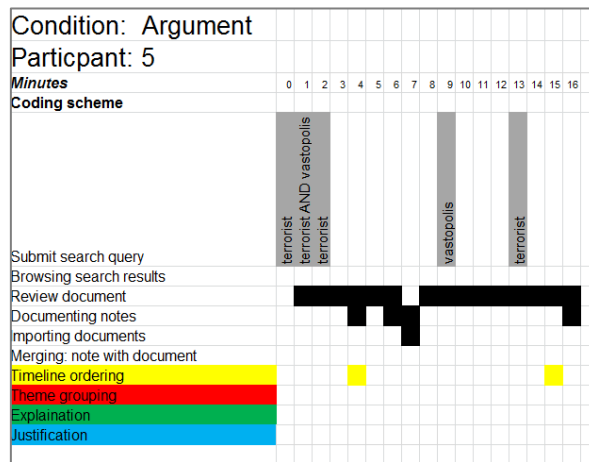
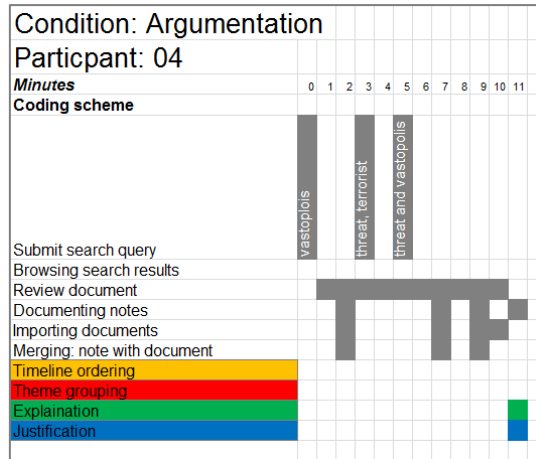

# Appendices

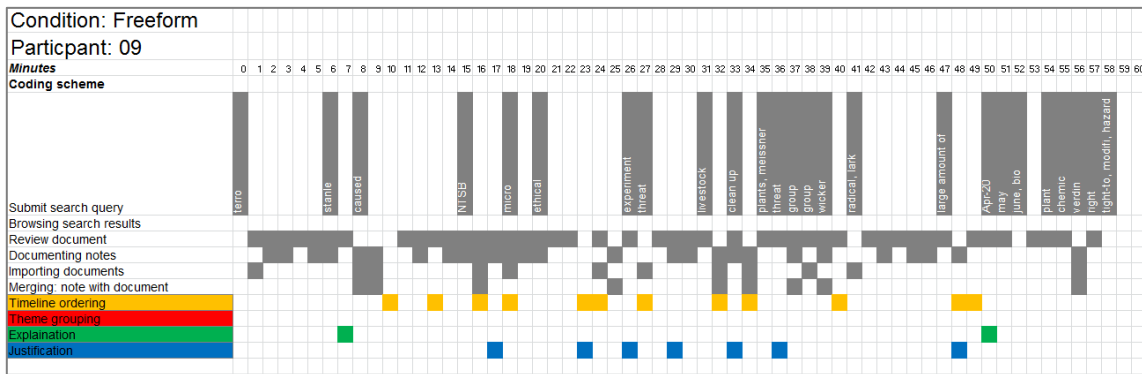
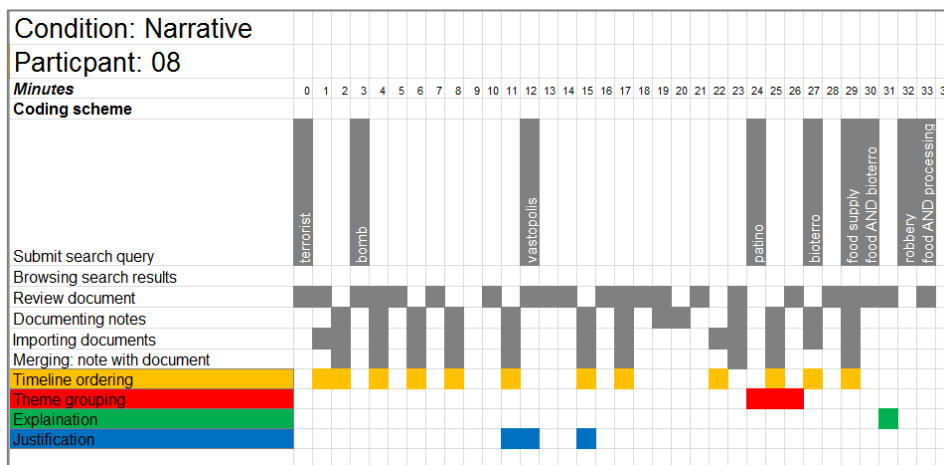
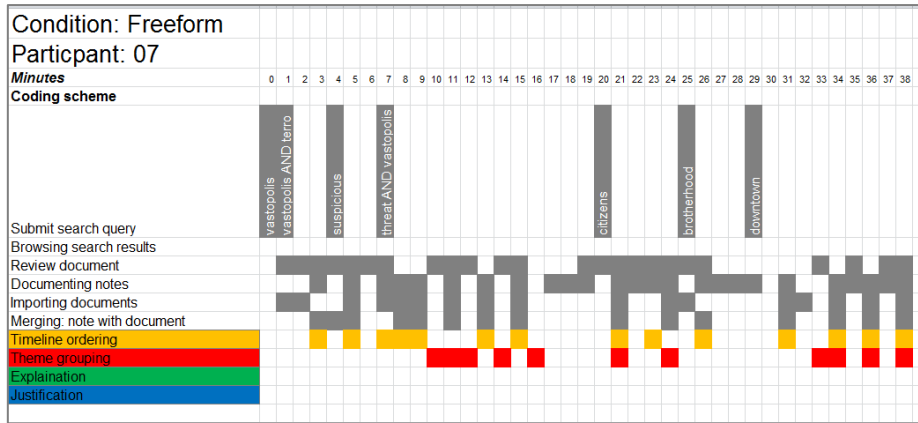



# Appendices

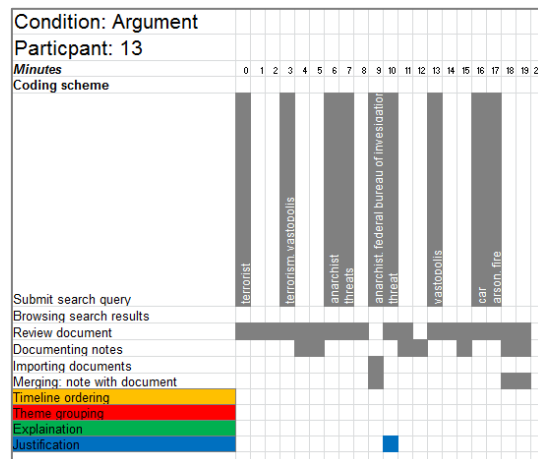
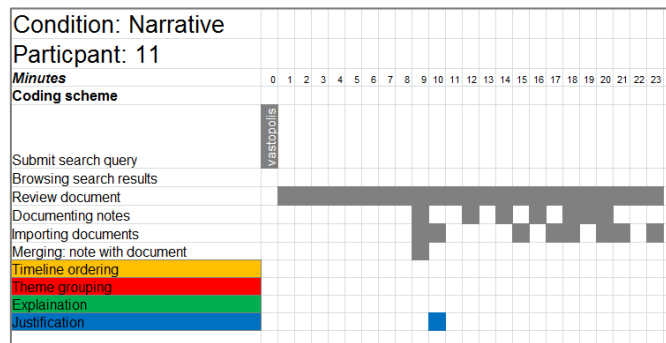
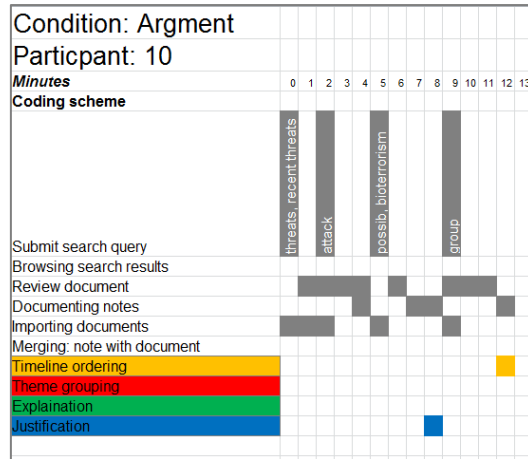

# Appendices

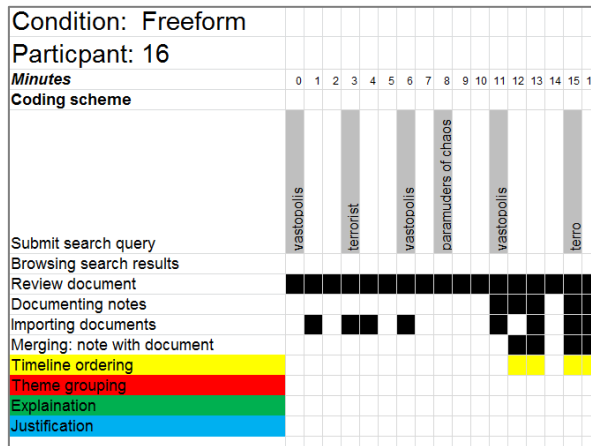
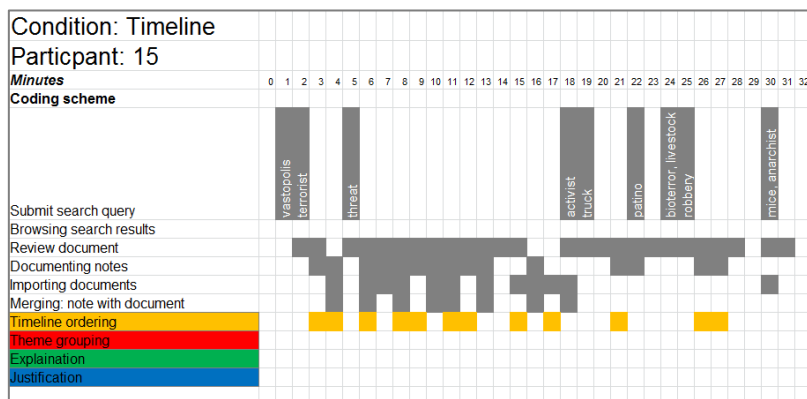
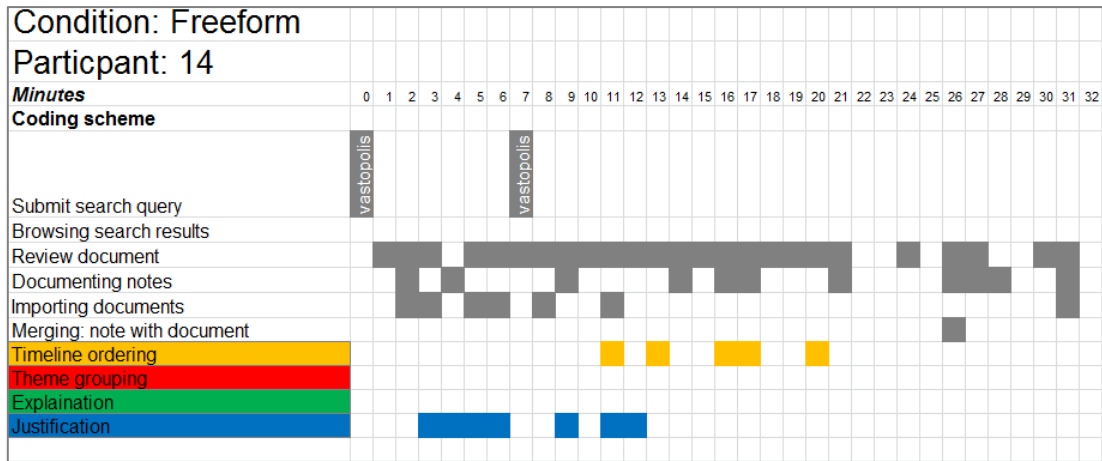

# Appendices

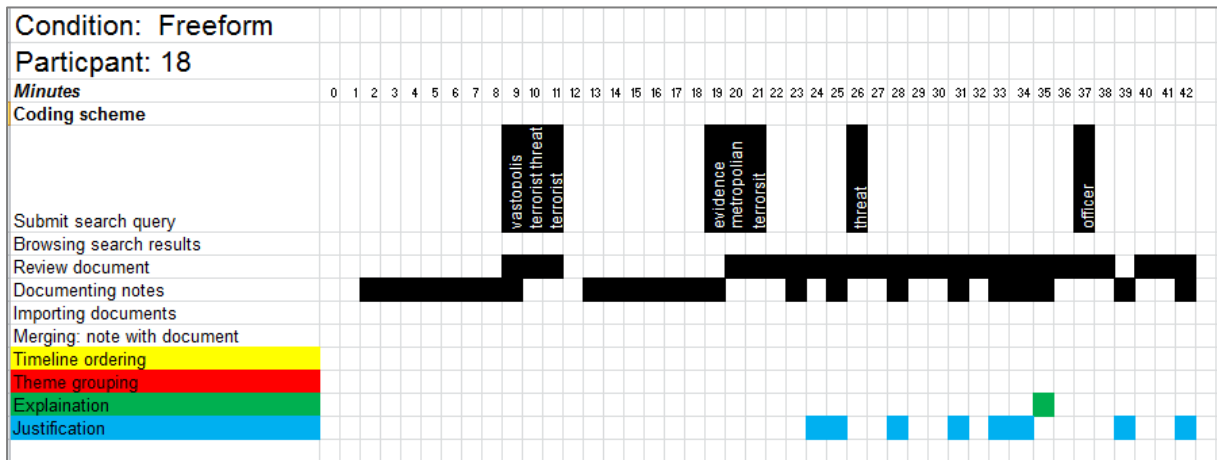
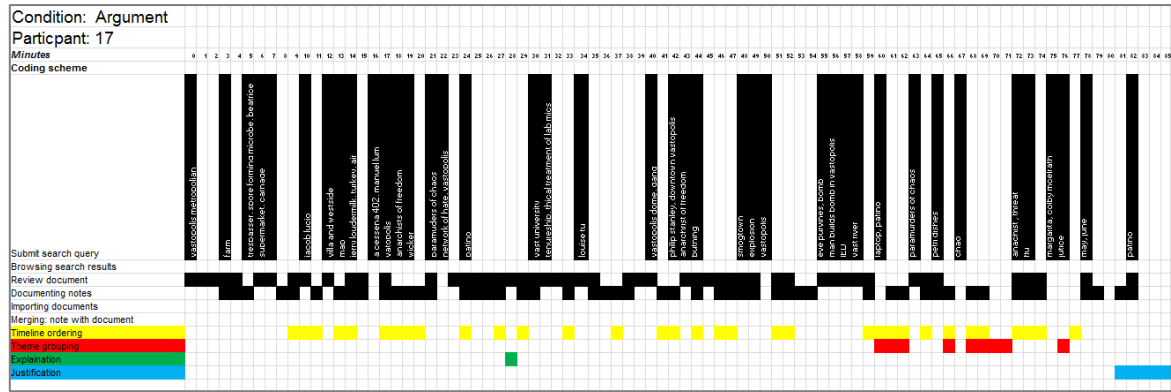

# Appendices

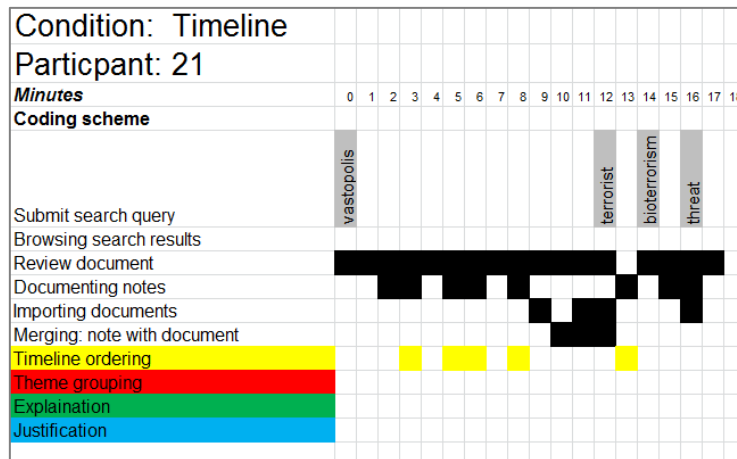
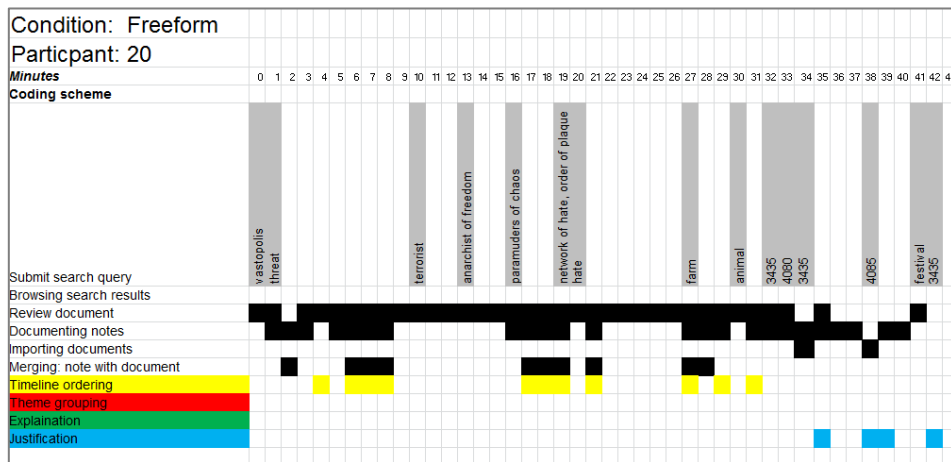
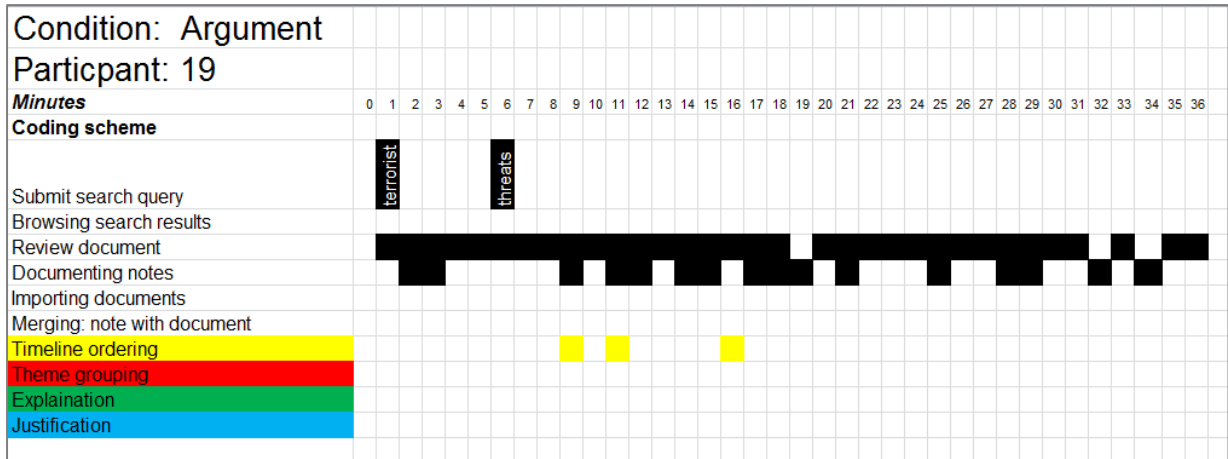

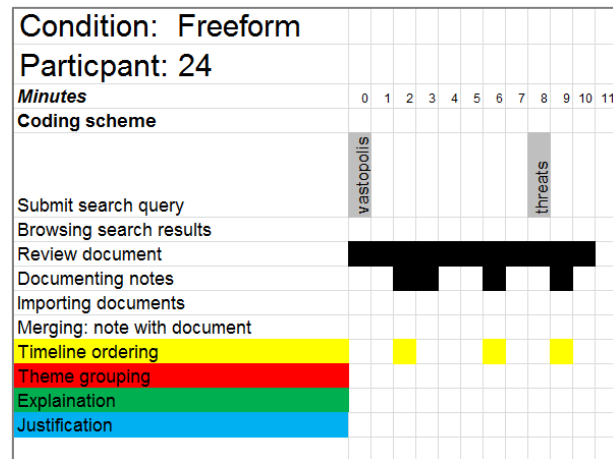
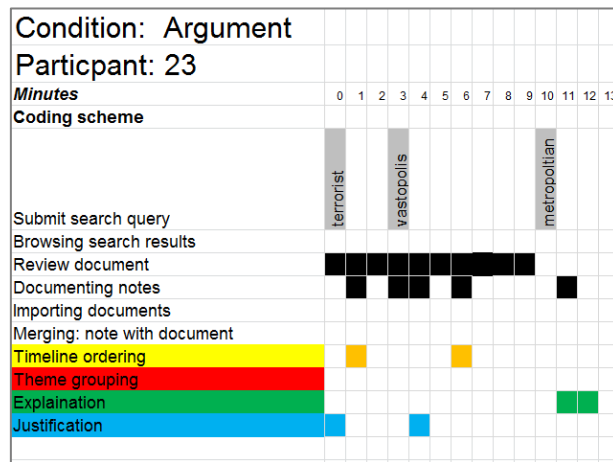
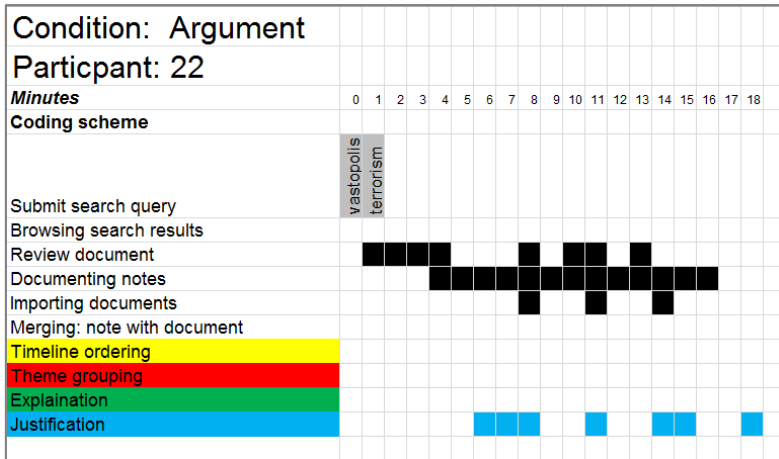





# Appendices

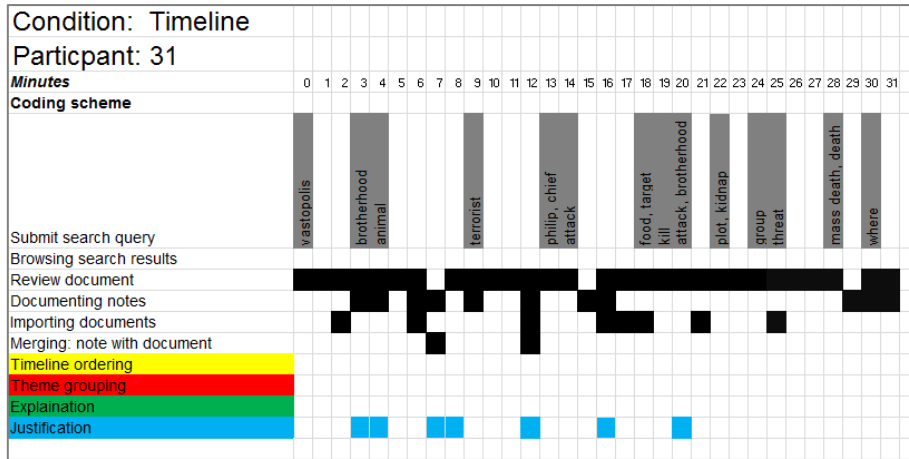



## 8.5 Appendix E: Other relations examples

### 8.5.1 Other information object surrogate relation examples

Figure 8-1 shows another example of the information object surrogate relation. This was created by participant 14. In the study, the user created these by (1) opening an information object from the search tool (Microsoft Windows Explorer) (on the left) by clicking on it to open it, (2) reviewing it, (3) copying the *title* of the information object from the information object and pasting it onto the representation interface (Microsoft OneNote) and (4) documenting the *date* the information object was published. The combination of both the summary (title) and the date elements (which are highlighted in the red rectangle on the right in figure 8-1) forms an information object surrogate.

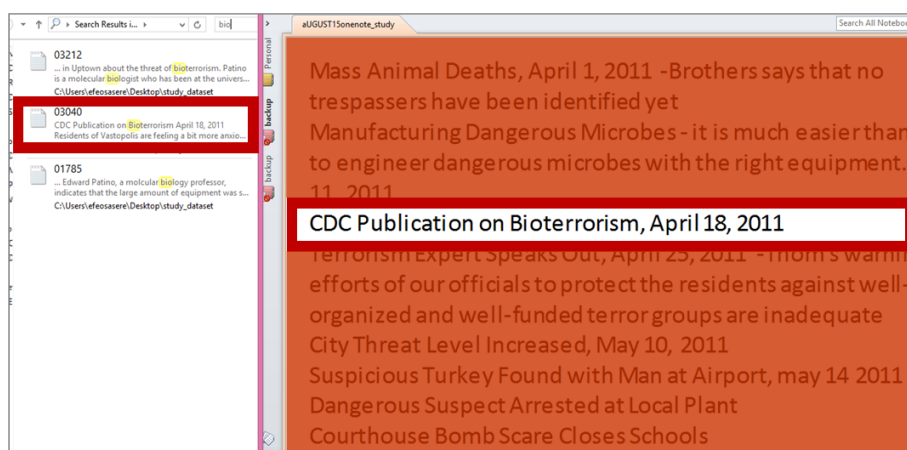

Figure 8-1: An information object surrogate relation with title and date elements created by participant 14

Figure 8-2 shows another example created by participant 7. In the study, the user created these by (1) opening an information object from the search tool (Microsoft Windows Explorer) (on the left) by clicking on it to open it, (2) reviewing it, (3) copying the *title* of the information object from the information object and pasting it onto the representation interface (Microsoft OneNote), (4) documenting the *date* the information object was published and (5) dragging an information object icon that represents a *source* from the search tool that displays the information objects into the representation interface. The combination of the summary (title), source and the date elements (which are highlighted in the red rectangle on the right in figure 8-2) forms an information object surrogate.

## Appendices

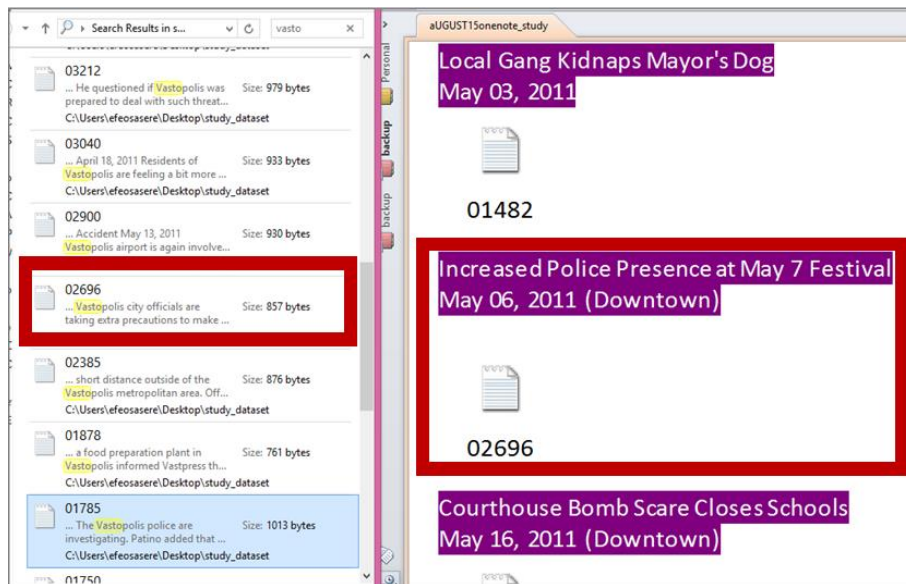

Figure 8-2: An information object surrogate relation with title, source and date elements created by participant 7

And here is another example created by participant 3 (Figure 8-3). In the study, the user created these by (1) opening an information object from the search tool (Microsoft Windows Explorer) (on the left) by clicking on it to open it, (2) reviewing it, (3) copying the *title* of the information object from the information object and pasting it onto the representation interface (Microsoft OneNote), (4) documenting the *date* the information object was published, (5) copying and pasting a significant subset of the content of the information object (*gist*) into the representation interface and (6) dragging an information object icon that represents a *source* from the search tool that displays the information objects into the representation interface. The combination of the summary (both title and gist), source and the date elements (which are highlighted in the red rectangle on the right in figure 8-3) forms an information object surrogate.

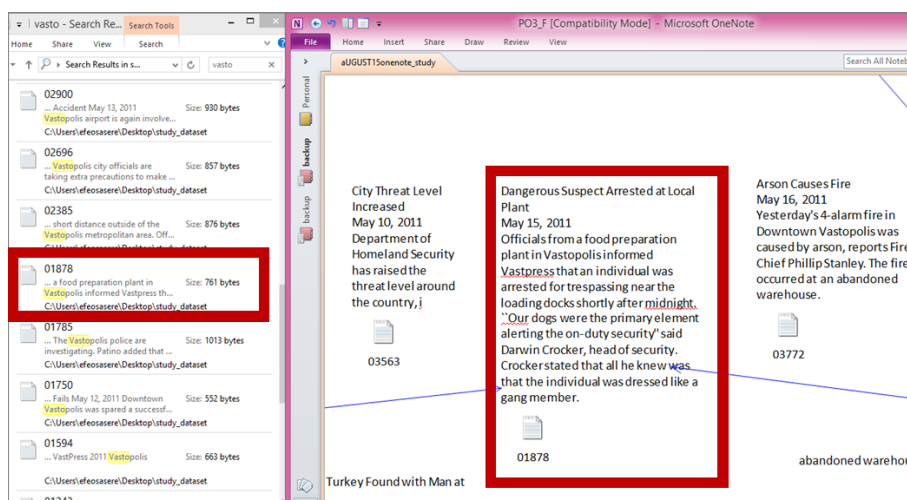

Figure 8-3: An information object surrogate relation with title, gist, source and date elements created by participant 3

## 8.5.2 Other timeline relation examples

Figure 8-4 shows another example created by participant 14. In the study, the user created these by (1) creating multiple information object surrogates (see information object surrogate section). They created information object surrogates consisting of the information object title, date of publication and a summary of the content of the information object. (2) Sorting them chronologically in a vertical line

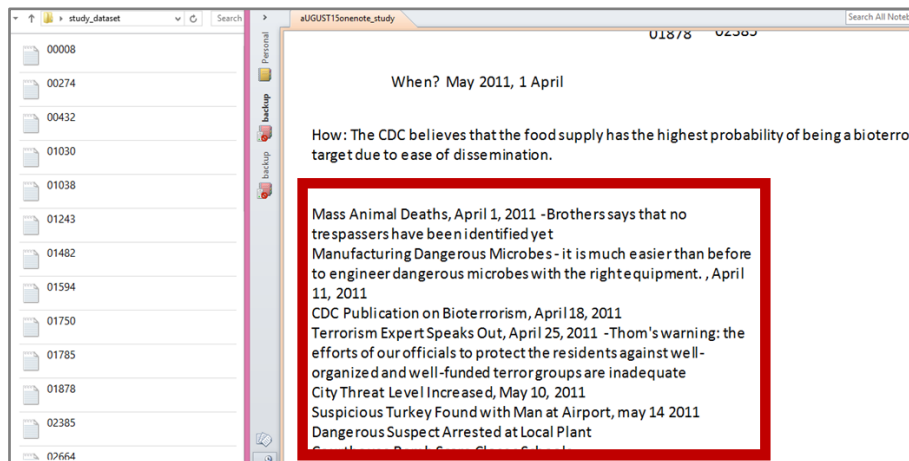

Figure 8-4: A timeline relation with title, date and gist elements created by participant 14

Figures 8-5 and 8-6 show another example created by participant 9 and 20. In the study, the users created these by (1) creating multiple information object surrogates consisting of date of publication (date) , summary of the content of the information objects (gist) and an information object icon or information object identification number that represents a *source* element. (2) Sorting them chronologically in a horizontal or vertical line.

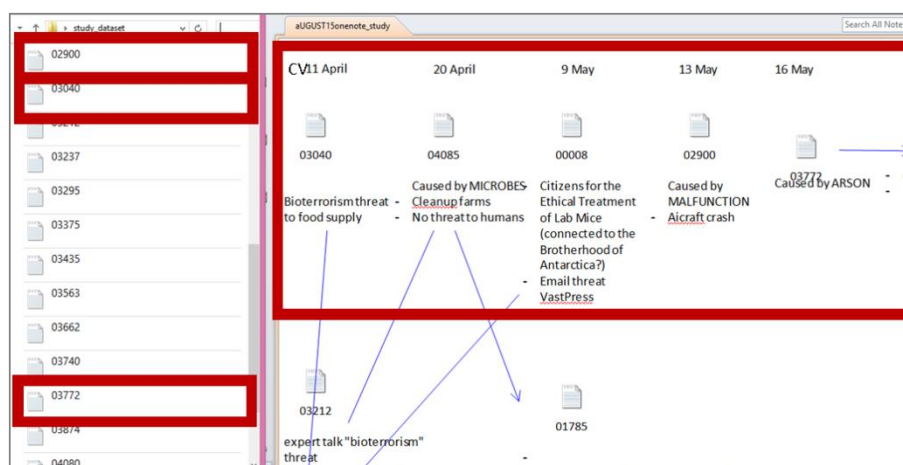

Figure 8-5: A timeline relation with date , gist and source elements created by participant 9

## Appendices

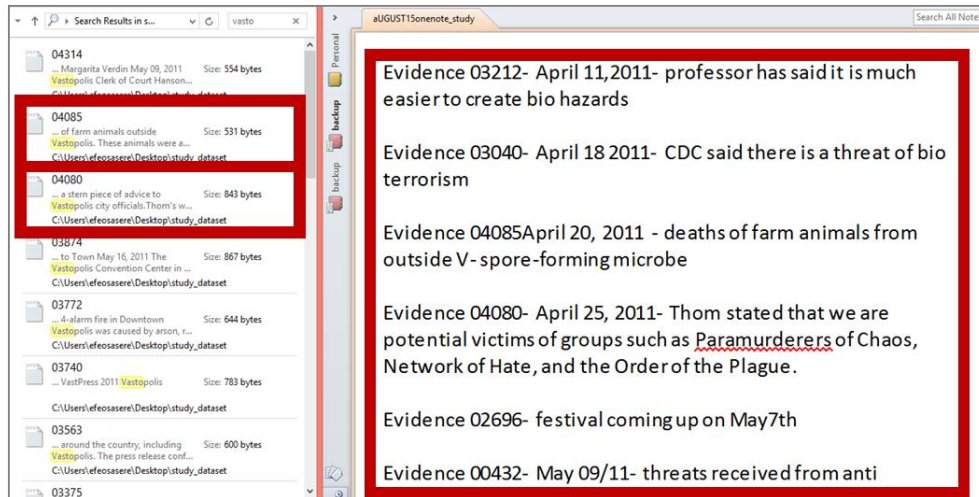

Figure 8-6: A timeline relation with date , gist and source elements created by participant 20

### 8.5.3 Other justification relation examples

Figure 8-7 shows another example of the justification relation which was created by participant 14. Here, the user is answering the question of how the threat is likely to occur which is also part of the questions they were asked to answer as part of their task. The user starts by (1) producing a claim “*The CDC [Centre for Disease Control] believes that the food supply has the highest probability of being a bioterrorism target due to ease of dissemination*”. (2) Then they created a *timeline* relation to support their claim. Each information object surrogate used in the timeline relation refers to events of threats.

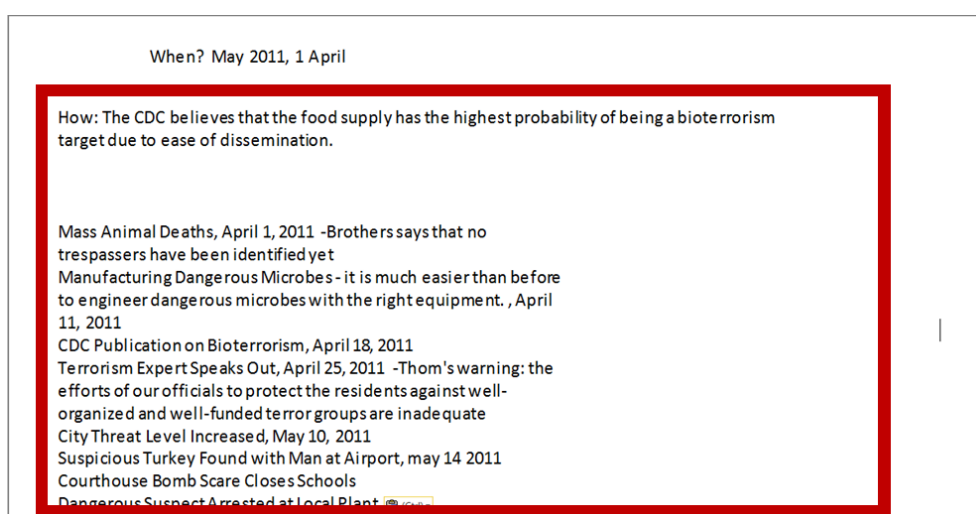

Figure 8-7: Justification relation with a single claim and timeline relation as evidential support

Figure 8-8 shows another example of the justification relation which was created by participants 18. The figure shows a *premise* with a *conclusion*. A premise is “*a previous statement or proposition from which another is inferred or follows as a conclusion*” (The Oxford English Dictionary, 2013) while a conclusion is a proposition concluded from one or more premise. In the red rectangle below, the user presents a premise “*Highly reliable sources reports that city administration officials...*” and it is interesting because the user’s conclusion is an imperative “*try to understand what is the reason for that?*” rather than a statement of fact. The combination of the premise and conclusion (which are highlighted in the red rectangle in figure 8-8) forms a justification relation.

**Where did attack happen? Public area, Shopping centre, Any embassy?**  
 The festival is coming! There will be a festival in Downtown on May 7. Vastopolis city officials are taking extra precautions to make sure the festival will be safe and fun for everyone.

**Try to understand what is the reason for that? If it is against to the country, We need to look at our country polices and relations with the others.**  
 Highly reliable sources report that city administration officials of Vastopolis were receiving threats now on a daily basis by a group of anti-government extremests calling themselves Anarchists for Freedom.

**Is it directly related with the president? Because of his/her behaviour or speech?**

**Is it related with religion? If yes, What might be the reasons?**

**In addition, after e general inspection, We need to be more specific about the terrorist threats.**  
 Terrorism Expert Speaks Out

Figure 8-8: A justification relation created by participant 18

Another example of a justification relation is shown in the representation created by participant 29 (figure 8-9). Here the user is trying to find out if the assumption that there is a possible terrorist threat is valid or not. The assumption comes from the task question itself. The user first produced (typed out) a claim “*these presumptions [of possible threat] may exist ...such as*”. They later produced (typed out) a list of *evidential supports* to support their reason “*a recent rousing talk delivered by Prof. Patino*”, “*some stern advice by terrorism(expert) author Jose Tom or*” etc. The combination of the claim and listed evidential support (which are highlighted in the red rectangle in figure 8-9) forms a justification relation.

In one raid, police apprehended three people who were in the middle of constructing some laboratory. For some reason, they destroyed evidence (equipment) rather than escaping. There has been detailed investigation into this. However, again, it seems to be a high-end workbench and something concrete in terms of an act of terrorism can not be established.

These presumptions may exist because of some recent talks/publications in April 2011, such as  
 a recent rousing talk delivered by Prof. Patino  
 some stern advice by terrorism (expert) author Jose Tom or  
 A CDC publication on bioterrorism by Dr. Bryant Mcfarlane.

These talks may have resulted in discussions of an eminent terrorism threat, however, as such, it seem that these are only 'discussion' and lack evidence in terms of something concrete.

Figure 8-9: A justification relation created by participant 29

