

FROM FREUD'S UNCONSCIOUS TO LACAN'S  
SUBJECT, identification from Freud to Lacan via Conté

A thesis submitted to Middlesex University

In partial fulfilment of the requirements for the degree of Doctor of  
Philosophy

Hariklia Pepeli

School of Health and Social Sciences

Middlesex University

5 January 2010

## ABSTRACT

The thesis starts with the question: 'Does there exist a subject in Freud?' and looks for answers first in Freud's early formulations of the psychical apparatus in the 'Project' (1895), 'Letter 52' to Fliess (1896), then Chapter VII of 'The Interpretation of Dreams' (1900), that is his first topography. The answer confirms our claim that there exists a subject in Freud, that it is unconscious and that it is largely included in and concealed by the Freudian term of 'ego' (*Ich*).

In Chapter 2, our claim is carried forward through the second period of Freud's work to another aspect of *Ich*, not as unconscious, but as the narcissistic ego. Freud's introduction to the theory of narcissism (1914c) highlighted the dimension of ego as a libidinal object and its role in psychosis. The metapsychological papers, 'Drives and their Vicissitudes' (1915c), 'Repression' (1915d) and 'The Unconscious' (1915e) proved on the other hand that Freud had not abandoned his research on the structural, the symbolic dimension of the ego (*Ich*).

In Chapter 3 the thesis focuses on two particular aspects of Freudian metapsychology, the structure of the ideals and identification. The sub-claim here is that identification in Freud is not simply an imaginary process involving regression from love, but also a particular substructure of the 'ego'. We develop this claim through the study of 'Group Psychology' (1921c) and Freud's second topography in the 'Ego and the Id' (1923b).

In Chapter 4, we present a post-Freudian, object relations, view of the psychical structure, that is D. Lagache's : 'Psychoanalysis and Personality's Structure' (1958) and Lacan's own counter-presentation of the psychical structure as an 'Optical Schema' (1958), named after a model he adapted from experimental 19<sup>th</sup> century physics.

In Chapter 5, we present Lacan's largely unknown theory of identification, as he developed it in Seminar IX *Identification*(1961-1962), first the identification of the subject to the signifier, then to object *a*. This supports our final claim that the formalization of object *a* and the status of the Real were first developed in Seminar IX, which is before Seminars Book X and XI.

In Chapter 6, we present two major contributions by C. Conté , 'The Splitting of the Subject and his Identification'(1970) and 'Topological Surfaces' (1993) which lead us to conclude that Topology and the Real are the areas of research most suited to contemporary psychoanalysis which only now begin to show their relevance.

## ACKNOWLEDGMENTS

I owe the inspiration for this work to Claude Conté, analyst and supervisor who died tragically in 1992. I owe its completion to the director of my thesis, Bernard Burgoyne, colleague and teacher who encouraged me throughout it. I finally dedicate this work to my deeply missed husband, companion and supporter Robert Jackson, who also died unexpectedly three years ago in the midst of a life full of promise still; to my late mother too, who had placed so many hopes in me.

## CONTENTS

Introduction .....	1
Chapter 1 Does there exist a subject in Freud ?	24
Chapter 2 The insertion of narcissism.....	79
Chapter 3 Identification in Freud.....	133
Chapter 4 The Optical Schema.....	193
Chapter 5 Identification in Lacan.....	260
Chapter 6 Conté's Contribution ....	313
Bibliography .....	372

## INTRODUCTION

### A. The Freudian *Ich*

In this thesis I argue that the Freudian *Ich* has been largely misunderstood in post-Freudian, psychoanalytic theory and that its mistranslation as ‘ego’ by Strachey in the Hogarth *Standard Edition* contributed to its distortions. My first claim is that Freud’s term and concept of *Ich* covers a much wider field, has a much wider remit: It is not only the preconscious ego of verbal associations and imaginary identifications, the unified and projected surface of the body, or its protective shield, and it is not to be confused with consciousness. It is the psychological apparatus in its totality including an ‘unconscious ego’, as Freud argued in ‘The Ego and the Id’ (1923b). Its structure and relations to the libidinal body and its projections were continuously developed by Freud. At the end of his work a new development underlined the process of ‘splitting in the ego during the process of defence’ (1940e [1938]), bringing it closer to the concept of a divided subject, as Lacan developed it in his work. In the ‘Project for a Scientific Psychology’ 1950a [1895]), the earliest metapsychological development by Freud, *Ich* was the totality of the psychological system ( $\psi$ ) and in particular the instrument of defense, against the excess of excitation; but it was also the core of  $\psi$  where desire resided. Furthermore, in the unconscious formations such as the dream, the parapraxes and the joke, the subject was disguised and fragmented in its identifications; it was the ambiguous ‘I’ of the sentence, equivalent to the grammatical subject, called appropriately in linguistics the ‘shifter’.<sup>1</sup>

---

<sup>1</sup> Thus, not only the first but also the second topography of Freud were misunderstood, as the translation of

Freud introduced the term *Ich* as early as the ‘Project for a Scientific Psychology’ (1950a [1895]). From the totality of the  $\psi$  processes it was narrowed to its kernel, the place of desire and repetition (*Begierde im Ich*, Project Part III, S. E., 1, 361), but it was also on the surface of the nervous system designated there as a particular ‘group of neurons,’ with a special task to protect the psychical organism from damage due to excessive excitation, and ensure its smooth functioning. The nervous excitation was defined as ‘neuronal quantity’ ( $Q\eta$ ); it was transmitted through the paths (*Bahnungen*) of neuronal conduction ( $N$ ), and from there it rushed initially for discharge to the other end of the apparatus.

Freud presented first the psychical apparatus as a kind of reflex arc and the specialized function of ‘ego’ (*Ich*) as a differentiated organ offering cumulative resistance and defence thanks to the contact-barriers, Freud’s intuition of the soon to be discovered ‘synapses’ (*Kontaktschränken*). It was first the instrument of inhibition and defence. The whole apparatus  $\varphi\psi\omega$  or *Ich* was subjected (*subjicere*) to the principle of inertia, or at least to that of the lowest possible level of tension, keeping away excessive excitations from  $\varphi$  (external sensations). The ‘primary processes’ in  $\psi$ , those of desire and its return were delayed through various checks by  $\omega$  before the experience of satisfaction, through secondary processes. The psychical apparatus in the ‘Project’ (1950 [1895]) was thus the complete subject of psychical experience<sup>2</sup>, where pain and affects and the experience of satisfaction accumulated, but primarily of unpleasure, mitigated defence, *inhibition* and

---

the famous Freudian aphorism testifies: *Wo es war, soll Ich werden*: ‘Where *id* was, there *ego* shall be’ (Freud, S., 1933a, S.E. 22, 80). Lacan mocked the French translation: *le moi doit déloger le ça*, and proposed: ‘where *it* was, the *Ich*-- the subject, not psychology-- the subject must come into existence’ (Lacan, J., *The Four Fundamental Concepts of Psychoanalysis*, 1964, Seminar Book XI, 1981, 45).

*repression*.<sup>3</sup> Primary processes aimed at discharge, either immediate satisfaction or hallucination of it, which often threatened the subject's very existence. Defences interfered with the desiring processes in  $\psi$  assisted by indications of reality or quality (*Realitäts--/Qualitätsprüfungen*), provided by the  $\omega$  neurons. In the 'Project' (1950a ([1895]), as Lacan argued: 'It all seems to happen in the same place, on the same surface'<sup>4</sup>.

During the second period of his work (1914-1918), just ahead of the five known metapsychological papers, Freud introduced the concept of narcissism in psychoanalysis which he found in psychiatry and literature, and adapted it to his own theory, inserted it to the libidinal logic as a narcissistic ego, object of libido. Narcissism was responsible for the appearance of 'ego' as an entity not existing from the beginning, but formed after the period of autoerotism, able to become object of libidinal investment. Lacan compared it to his mirror stage. Freud talked of an ideal ego (ideal-Ich) and of narcissistic object-choice.

In the third period of his work, following his major theoretical shift in 'Beyond the Pleasure Principle' (1920g) with the compulsion to repeat and the death drive, Freud abandoned the old psychical structure for a new entity, but highly differentiated, a new conception of the 'ego'. 'From the opening of 'The Ego and the Id'(1923b), Freud

---

<sup>3</sup> Freud underlined that the ego has to obtain satisfaction 'by its influencing the repetition of experiences of pain and of affects, and by the following method, which is described generally as *inhibition*'. (Freud, S., 1950 [1895], S. E. **1**, 323)

<sup>4</sup> 'It seems obvious to me that this apparatus is a topology of subjectivity, of subjectivity insofar as it arises and is constructed on the surface of the organism.' (Lacan, J., 1959-1960, p. 40). The symbolic function was stressed in Seminar Book II, *The Ego in Freud's Theory and in the Technique of Psychoanalysis* (1954-1955). Consciousness was nothing more than a reflexion, either on the mirror, or on any other reflective surface, and did not presuppose a subject, while 'The unconscious is the unknown subject of the ego' (Lacan, J., 1954-1955, p. 43). What is the 'ego' then? Lacan asked. The ego is an object. As we see in Freud, the split is between ego-subject and ego-object, symbolic and imaginary. In Seminar Book XI *The Four Fundamental Concepts of Psychoanalysis* (1964), Lacan was uncompromising: 'It is not a question of the ego in this *soll Ich werden*; ... throughout Freud's work the Ich is the complete, total locus of the network of signifiers, that is to say the subject, *where it was*, where it has always been, the dream.' (Lacan, J., 1964, p. 44)



acknowledged that although ‘the division of the psychical into what is conscious and what is unconscious’, on which his first topography was based, would always be useful –and remained the fundamental premise of psychoanalysis- it became obvious to him that it could not stand the structural scrutiny. In the presentation of his first topography, consciousness risked to be considered as ‘the essence of the psychical’, although it was only a quality of it. The distinction between a topographical unconscious, ‘the repressed’, and ‘a dynamic unconscious, ‘the preconscious,’ was not clear –the former could become conscious and did so with its connection to verbal associations- and risked to support the idea of an unconscious consciousness, something which would satisfy the philosophers but not the psychoanalysts. The concept of a ‘third unconscious’ was needed, an unconscious ‘ego’ which behaved like the repressed although it was not repressed. Freud named it consequently ‘id’ (*Es*), following an idea from Groddeck. The totality of the ego proposed by Freud in his second topography was called *das gesamte Ich*, it had protuberances and extensions, and it was an entity made of distinct areas merging into each other with splits and fragmentations along the seams. Only to a part of it ‘consciousness attached.’<sup>5</sup> This was also shown in the formation of the ego through identifications, first formulated in ‘Group Psychology and the Analysis of the Ego’ (1921c)’ and then again in ‘The Ego and the Id’ (1923c).

The first three chapters of the thesis are organized around the first claim, that there exists a subject in Freud, which in the ‘Project’ is a  $\phi\psi\omega$  continuity of primary and secondary processes, it is laid down in successive strata of writing perhaps topographically separated in Letter 52 to Fliess, or it is a succession of memory traces as recordings audio and visual,

---

<sup>5</sup> Freud, S., (1923b), ‘The Ego and the Id’, S.E., **19**, 13ff

within a complex camera like apparatus ('The Interpretation of Dreams', 1900a). The term unconscious was introduced gradually first as the adjective 'unknown' (*unbewußt*) as in *Unbewußtzeichen*, 'unconscious signs of perception' or unconscious memory, then as the system which Freud will call 'The Unconscious' (*das Unbewußte*, 1915e) in the second period of his work. The third chapter develops the idea that Freud's concept of identification is not merely inscribed in narcissism, but is part of his structural conception of *Ich*.

We examine Narcissism in the beginning of Chapter 2 which is also inscribed in Freud's structural approach of *Ich*, but it inserts in it his libidinal theory. Freud's theory of libido was thus proven valid not only for the study of neurosis, homosexuality and generally the love life, but also of psychosis. The ego-subject could become an object of libido. The initial libidinal investment of the body and its erogenous regions, autoerotism, was transformed into narcissism through the newly formed entity of the ego which became the reservoir of libido. Freud's paper 'On Narcissism, an Introduction' (1914c) introduced the notion of the ideal, although 'ego ideal' and 'ideal ego' were terms used indiscriminately there. It would take Freud some years to develop the theory and structure of the ego ideal but its differentiation from the ideal ego, although implicit was not possible for Freud. Lacan attributed this to Freud's non-differentiation between imaginary and symbolic registers. 'Drives and their Vicissitudes' (1915c), 'Repression' (1915d), and 'The Unconscious' (1915e) are the three metapsychological papers which interest us, insofar as they offer a theory of *Ich* which is structural. The split between *Ich-Subjekt* and *Ich-objekt* was presented there in the investments of the drive, as well as the idea of the original

autoerotic ego as real, or the insufficient differentiation of the unconscious as the repressed, and truly inaccessible, topographic unconscious, while the dynamic unconscious could overcome repression, or the Thing-Representations (*Sachevorstellungen*) which could become conscious through 'Word-Representations' (*Wortvorstellungen*).

Freud's structural preoccupations were also present in 'Formulations on the Two Principles of Mental Functioning' (1911b). Through autoerotism *Ich* was set to become *Lust-Ich*, only 'pure pleasure ego', acquiring all the good objects inside, while all the indifferent, hostile, foreign to the ego objects were ejected in the outside. The 'reality ego' (*Real-Ich*), which Freud developed in 'Formulations' was not the *Real-Ich* of the drive. It was a simple successor of *Lust-Ich* to safe-keep the pleasure principle. Thus the return of unpleasure (*Unlust*) both in the neurotic symptom and in the dream, needed a better explanation than Freud's metapsychological theory of the first two periods of his work.

Freud's paper 'The Unconscious' described two kinds of 'Unconscious', 'the topographical' true unconscious, the repressed, and the 'descriptive' or 'dynamic' unconscious, the preconscious (1915e). In 'Drives and their Vicissitudes', 1915c, Freud went beyond the conception of a *Real-Ich* replacing a *Lust-Ich*. From the *initial Real-Ich* a part was split as *Lust-Ich* and another part was non-ego (*not-Ich*), external space filled with what was foreign to the ego, indifferent or hostile object. The split was established between an external and an internal space, which was misunderstood as projection, as within the specular logic, while on the contrary it was a topological conception of the subject. It was not a topographical space, internal-external, but two different *topoi*, and that beyond the

illusion of symmetry, which the terms ‘introjection’ and ‘projection’ (1915c), reinforced. This is why we argue that we need to use ‘topology’, rather than topography, in psychoanalysis. The theoretical frame of psychoanalysis, the study of concepts, does not make its formulations part of philosophy or anthropology, but part of the sciences of logic, mathematics, and topology.

Freud had first the intuition of the psychical space as ‘another scene’, a term he borrowed from Fechner. He used schemata, diagrams, and other graphic representations to show aspects of what he called ‘our psychical topography’ (1915e). He used the term *Topik* which had its origins in Aristotle. Freud’s *Topik* was the study of *topoi*, and *topoi* in classical logic were places in discourse, common places, but first of all recurrent themes or patterns in discourse. They therefore implied a logical space. As Freud understood, our psychical topography (*Topik* or *Localität*) was not anatomical, but conceptual, logical. Topography in Freud and topology in Lacan are two different intuitions of the psychical space but it would be wrong to argue that they have nothing in common.

Topology is a special branch of modern mathematics. As such it appears in the beginning of the 20<sup>th</sup> century with Dedekind’s first intuition (1900), and develops with Bourbaki from the 1950s onwards and for the next thirty years. We also have the topologies of Freshet, Sterpinski, Hausdorf, and Lobochevsky in the first decades of the 20<sup>th</sup> century. In the 17<sup>th</sup>, 18<sup>th</sup> and 19<sup>th</sup> century Leibnitz, Euler, and Poincaré were all working with topological problems and used algebra and geometry. There are today two branches of topology, algebraic topology which uses lower level spaces of maximum four dimensions, and

general topology using set theory. Freud's 'topographies' are schematic representations of the psychical apparatus using diagrams and geometrical figures. Their intention is to show the structures and substructures at play in the workings of that apparatus. In that sense they can be transformed to topological figures. Lacan (1959-1960) saw the 'Project' as a topology of subjectivity; Vappereau (1988) applied the Freudian schema of the psychical registrations from Letter '52' to Fliess on Lacan's schema  $R$  or projective plane. The second topography was described by Lacan as a topology of the sphere showing the bag of drives (1974-1975). The Ego (*das Ich*) of the second topography was not only the surface of the body, the protective membrane of the organism against excess external excitations which Freud had described in 'Beyond the Pleasure Principle' (1920g), but also the internal projection of that surface. There was a potential of topology in the second topography which Lacan saw very well. The ego extended downwards, dipped its roots in the id, as for the repressed, which, although cut-off from the ego, continued to communicate with the id. There were 'internal' perceptions and thoughts, some went as far down as the bottom of the eye shaped figure and some were preconscious, in the middle. Then Freud reversed the 'vectorialization' of the construction later, in the 'New Introductory Lectures' (1933a). The repressed was not completely cut-off. The superego which in 'The Ego and the Id' (1923b) was in relation to the external world, was worn by the 'ego' as a cap, the cap of hearing, and worn 'awry', became an integral part of the structure, perhaps the most archaic, in any case inheriting the drives from the 'id'. The whole entity (*das gesamte Ich*) was quite complex, and not as smooth as some would have liked it to be. It was like 'the germinal disc sitting at the top of the ovum'. On the other hand, in 'Lecture XXXI' of 'New Introductory Lectures'(1933a), the 'id' was the most archaic part, from which the ego and

the superego developed upwards or outwards. The whole entity looked like an eye, *I*, as Lacan noted. In Seminar *RSI* (1974-1975) the subject, *S* is in conversation not only with the Other (*A*), but also with *a* (*Sa, ça*), a quite peculiar ‘conversation’ indeed without words. Referring to the aim of the treatment Freud had concluded Lecture XXXI with his famous ‘*Wo es war soll Ich werden.*’ But was it an operation of salvation in order ‘to strengthen the ego’ as some following some misunderstood Freudian formulations had suggested, or a topological operation as Lacan implied? <sup>6</sup> In the construction of the psychical apparatus, time was a third, topological dimension.

The lack of a proper topological support led to a misunderstanding of Freud’s topographies, especially the second. A new psychoanalytic theory emerged which gave the central place to the ego as the agent of psychological synthesis, autonomy and adaptation to reality and made it the ally of the psychoanalytic treatment. <sup>7</sup> On the other hand, the ‘object relations’ theory saw the ego as weak in its dependency on the id and the superego and sought in the external object the object of desire. The ‘object relations’ theory saw the end of the treatment in the union with the object found in the effusion of love. Identification with the object as ideal led to the ego’s strengthening and education. <sup>8</sup>

---

<sup>6</sup> Lacan, J., The Four Fundamental Concepts of Psychoanalysis, Seminar Book XI, 5 February 1964. Cf.: This thesis, this Introduction, note 1, p. 1.

<sup>7</sup> Hartmann, H., Kris, E., and Loewenstein, R. were the ‘ego psychology’s founding trioka. In their paper ‘Comments on the formation of psychic structure’ they wrote: ‘Functions of the ego centre around the relation to reality. In this sense we speak of the ego as of a specific organ of adjustment.’ (*The Psychoanalytic Study of the Child*, Vol. II, *Imago*, 1946). In his book *Allgemeine Neurosenlehre auf Psychoanalytischer Grundlage* (1932), translated as *Principles of Psychoanalysis*, (1955), Nunberg recommended Hartmann’s papers for the question of adaptation to reality (Nunberg, H., op. cit., Ch. V, ‘The Psychology of the Ego’, 135), For a critique of *Ego Psychology* see Lacan, J., Seminar Book II, *The Ego in Freud’s Theory and in the Technique of Psychoanalysis* (1954-1955), especially session 17 November 1954.

<sup>8</sup> Balint, M., ‘Strength of the Ego and its Education’ (1938), in: *Primary Love and Psychoanalytic Technique* (1952).

In fact, both schools defined the end of the treatment as strengthening of the ego through its identification to the ego ideal. They both seemed to have forgotten that Freud wrote ‘The Ego and the Id’ (1923b) after ‘Beyond the Pleasure Principle’ (1920g), where he had developed a compulsion to repeat obeying a rather darker tendency of the ego. This work led Freud to slowly alter his views that the only conflict was between ego and sexuality as first expressed in ‘The Three Essays’ (1905d), and then in the second period of his work (1911-1918) where narcissism, the ego’s self-preservative, self-interest drives were opposed to the sexual drives, aiming at satisfaction (although always incomplete, as the initial object of desire was lost and the external object was always a substitute. Indifferent to the individual’s survival, the sexual drive led him to a darker polarity in which *Thanatos*, the death drive, was the aim of life, and *Eros*, the preserver of life, who resided in the id, the reservoir of libido, from an agent of unification and love would be exposed to the attacks of *Thanatos* leading to the diffusion of drives and the destruction of life. The sexual drives were thus weakened by the death drive. By wanting to attract libido to it, by wanting to become lovable, the ego could cause a defusion of drives, and its masochistic tendencies could result either in their desexualization or their sublimation.<sup>9</sup> As a result of the ego’s tendencies, and the silence of the drives reigning in the id, the death-drive *Thanatos* seemed to be the stronger drive. That was a situation which needed to be addressed, and it did in later Freud.

In the period which followed ‘The Ego and the Id’ (1923b), Freud oriented himself to a reworking of the ego’s relation to reality, and we know that the function of reality had been

---

<sup>9</sup> Freud, S., (1923b), S.E. 19, 46. Here the ego draws in libido from the id, this becomes desexualised or sublimated libido: ‘In this case the ego works in opposition to Eros.’

first attributed to the ego, although to a particular part of it, attention, and  $\omega$  neurons ('Project'). He started his revision in two papers 'Neurosis and Psychosis' (1924b), and 'The Loss of Reality in Neurosis and Psychosis' (1924e), then he continued with the papers 'Negation' (1925h) and 'Fetishism' (1927e) to explore the relation of the ego (*Ich*) to reality and especially to the lack, namely the lack of penis in women. With his last work, 'The Splitting of the Ego in the Process of Defense' (1940c [1938]), Freud approached this theme and reached the limits of symbolization.

## **B. Between language and sexuality**

In his first 'topography' Freud placed the *unconscious* between *perception* and *consciousness*, but on 'another scene' (*eine andere Szene*). During the ten years which followed (1900-1910), he researched its manifestations in the dream, where the subject, spoke but in the impersonal mode, the parapraxes and slips of the tongue of the 'psychopathology' of everyday life, or in the strategies of jokes addressed to the third person (*die dritte Person*), and also in the language of the neurotic symptoms. All those formations of the unconscious were carried through the rhetorical devices, condensations and displacements, double meanings, and other figures of speech.

Freud, however, needed a theory to account also for the quantitative factor, the *excess sexual excitation*, the cause of neuroses, and that theory was first 'the sexual trauma' and then 'the sexual fantasy'. Since the 'Project' (1950a [1895]) 'desire in the ego' (*Begierde*



*im Ich*) caused high levels of tension and even hallucinatory satisfaction, which could be damaging. Freud developed, independently, a theory of sexuality as governed by the part-drives, seeking perverse satisfaction (autoerotic) around the orifices of the body ('Three Essays on the Theory of Sexuality', 1905d). The science of his time provided him with two terms, the Latin 'libido' which he used to denote the energy of the sexual drive as a whole, and the German 'Lust' which 'was unfortunately ambiguous' (1905d, S. E., 7, 135), and therefore not fit for his purpose, as he said in a note added to that work in 1910. Why 1910? Because around that time Freud was developing his theory of narcissism and in 'Formulations on the Two Principles of Mental Functioning' (1911b) he used the German term *Lust* to create a distinction in the *Ich*, till then only autoerotic and almost autistic: *Lust-Ich* was opposed to *Real-Ich*, a differentiation or even a splitting in the original, primitive ego. *Lust* which 'denotes the experience of both, need and satisfaction,'<sup>16</sup> became synonymous of pleasure and not of lust or desire. It was a term which Freud will use in his new theories concerning narcissism and the destinies of the drives during the middle period of his work, the 'second Freud'.<sup>17</sup>

Chapter 2 of this thesis shows the transition to the 'second Freud' via 'Formulations on the Two principles of Mental Functioning' (1911b) and gives a special place to the pivotal text 'On Narcissism; an Introduction' (1914c). Using the specific terms 'pleasure principle' and 'reality principle' for the first time, Freud made a place for the pleasure principle in the formal structure of *Ich*, the 'pleasure ego' (*Lust-Ich*), and added a 'reality ego' (*Real-Ich*)

---

<sup>16</sup> Freud, S., 1905d, S. E. 7, 135

<sup>17</sup> According to Jean Florence, Lacan distinguished a first, a second and a third Freud. 1st) From 'On Aphasia' (1891) to 'Totem and Taboo' (1913 [1912]), 2nd) from there to 'Beyond the Pleasure Principle' (1920) and a 3d Freud after that. Freud had outlined, in a letter to Ferenczi, that 'his good work followed a seven year cycle, from 1891 to 1898, from there to 1905, to the first publication of the 'Three Essays', and from there to 1912, to 'Totem and Taboo', which he was writing at the time he sent his letter.

next to it; the quantitative element in the structure was taken into account as libido invested the ego now called the narcissistic ego, of which he had given an example with his study of Leonardo da Vinci. ‘Leonardo da Vinci’s Childhood Memory’ (1910c) was a study of both, narcissistic love and erotic identification to the mother. In fact, the concept of narcissism (*Narzissmus*) had been introduced earlier by Freud in a meeting of the Vienna Psychoanalytic Society, the 10<sup>th</sup> November 1909, and had appeared in a note added in the second edition of the ‘Three Essays on the Theory of Sexuality’, also in 1910.<sup>18</sup>

The expanded theory of the libido and the new category of the ‘ego drives’ (*Ich-Triebe*), next to the ‘sexual drives’, also introduced around the same time in ‘Psychogenic Disturbances of Vision’ (1910i), allowed Freud to reply to Jung’s criticisms and assert the validity of his theory of the libido for the psychoses too.

In Chapter 2 we also refer to the structural aspects of three of the five published metapsychological papers: 1) ‘Drives and their Vicissitudes’ (1915c) is a first formalization of the antithesis between ‘ego- non ego’ (*Ich / Not Ich*), between what is *indifferent, hated, or foreigner* to the ego in the external world (the indifferent and the hated object), and of the antithesis within ego (*Ich*) between being the *subject (Ich-Subjekt) of the drive* or its *object (Ich-Objekt)*, op. cit., S. E., **14**, 134). A crucial differentiation had indeed taken place in the primitive ego as a result of the encounter with the external object. The internal turmoil, the excess tension which was felt as *Unlust* was thrown out, confused with the external, foreign to the ego object, as source of unpleasure. The primitive ego (*Urich*) in its turn became ‘purified pleasure- ego’ (*Lust-Ich*), identified to the object taken within as

---

<sup>18</sup> For the term and concept of Freud’s *Narzissmus*: Cf. my developments in this thesis, Chapter 2.

source of pleasure (internal). As Freud declared in two of those papers, ‘Repression’ (1915d) and ‘The Unconscious’ (1915e): ‘our psychical topography (*psyschische Topik*) was finalized as ‘regions in the mental apparatus, wherever they may be situated in the body’<sup>19</sup>. He moved away from anatomy and the descriptive ‘psychology of consciousness.’ Freud insisted that the unconscious was not a ‘second consciousness’, and that the psychical reality was as unknown to us as physical external reality, indeed ‘as Kant warned us’ about the latter. But he softened his view immediately: ‘We shall be glad to learn, however, that the correction of “internal perception” will turn out not to offer such great difficulty as the correction of external perception - that internal objects are less unknowable than the external world’<sup>20</sup>.

Chapter 2 concludes with Freud’s structural remarks on paranoia deriving from his study of President Schreber’s ‘Memoirs of My Nervous Illness’(1903), the ‘Psychoanalytic Notes on an Autobiographical Account of a Case of Paranoia’, which was published in 1911 (1911c, S. E., **12**) straight after ‘Formulations’(1911b, S. E., **12**).

---

<sup>19</sup> Freud, S., (1915e), S. E. **14**, 175

<sup>20</sup> Freud, S., op. cit., 171. ‘Just as Kant warned us not to overlook the fact that our perceptions are subjectively conditioned and must not be regarded as identical with what is perceived, though unknowable, so psychoanalysis warns us not to equate perceptions by means of consciousness with the unconscious mental processes which are their object’(Ibid). However, in one of the last fragments he wrote Freud talked about ‘the dark self-perception of the kingdom of the *id*, not of the *Ich*.’(Freud, S., 1941[1938], G. W. 17, 452)

### C. Other views, wider context

In a paper published in 1984, Guy Le Gaufey, lacanian analyst, justly argued that in the Freudian text the subject was not ‘a concept determined as such.’<sup>19</sup> From there, he went on to say that, in the first topography, the Freudian *Ich* kept its ambiguity between ‘I’ (*je*) and ‘ego’ (*moi*), while ‘remaining within the realm of representation’. In the second topography, although closer to the notion of a subject because of its identifications, the ego continued to be ‘the direct consequence of the introduction of narcissism.’ His main argument was that the Freudian *Ich* cannot be ‘the subject’; it is the instrument for the distinction between ‘perception’ and ‘representation’, and, although Freud was not happy with it, *Ich* remained throughout his work largely equivocal. However, Le Gaufey’s sweeping argument on Freud’s *Ich* is contradicted by Freud’s constant preoccupation with its structure and functions (the two topographies of the psychical apparatus), what he called ‘the ego’s ‘institutions’ in another metapsychological paper: ‘A Metapsychological Supplement to the Theory of Dreams (1917d); with its dependent relations in ‘The Ego and the Id’ (1923b). In his two last works, ‘The Outline of Psychoanalysis’ (1940a [1938]) and especially ‘The Splitting of the Ego in the Process of Defence’ (1940e[1938]), he reworked the structure again. Le Gaufey however was not persuaded. He contrasted Freud’s conception of the *Ich* to Lacan’s theory of the *subject*. For him, the Freudian *Ich* remained equivocally within the realm either of symbolic *representations* (thoughts, ideas, memories) or of imaginary *identifications*, while Lacan’s definition of the subject as represented by the *by a signifier for another signifier* was an astute solution of Freud’s confusion. However, the Freudian

---

<sup>9</sup> Le Gaufey, G., ‘Freudian Representation and Lacanian Signifier’, *Littoral*, No 14, pp. 41-56, 1984. He argued there: ‘The classicism of Freud - and his scientism - are the reasons for this treatment of the subject, for this non-articulation which forces us to confuse its *obviousness* (classical universe) . . . with its *absence* (scientific universe)’ (Op. cit., 50-51).

*Ich* either as *I(Je)*, or as ego (*moi*), was a kind of quadrature of the circle, a division between ego and subject, as exemplified in Lacan's optical schema, where the subject was both in the gaze and in the ego ideal. This view was not freeing the subject from the burden of imaginary representations, although considering its division. Le Gaufey found in Lacan's mirror stage, the Schema L and the Optical Schema ways to encrypt the subject in the signifying metaphor of the eye. Despite its interest, Le Gaufey's argument has many flaws, because he privileges 'representation' concerning not only the theories of the Freudian *Ich*, but also concerning the Lacanian subject. For Le Gaufey, Lacan's axiom: 'the signifier represents the subject for another signifier'<sup>10</sup> would also have remained within the classical logic of representation, of representation of something 'internal' (the subject) for something external, if it was not for the linguistic splitting of representation (sign) between signifier and signified. So, while the subject takes the place of the originally repressed signifier (*Urverdrängt*), the second signifier becomes its representation, the subject is a signification. This indeed was what Lacan found in Freud's *Vorstellungsrepräsentanz*, 'the representative of the representation' (Seminar Book XI, *The Four Fundamental Concepts of Psychoanalysis*, 1964, op. cit., 218), and called it 'the binary signifier'.

But, the linguistic sign whose unity was split between signifier and signified, as in Saussure, and where the signifier took precedence over the signified, as Lacan proposed, was not enough to account for a subject. In his algorithms, in the signifying substitutions of metonymy and metaphor with which Lacan replaced Freud's condensation and

---

<sup>10</sup> This definition first appeared in Lacan, J.: 'The Subversion of the Subject and the Dialectic of Desire in the Freudian Unconscious' (*Ecrits* (1966, Fink, 2006, 694). That 'a sign represents something for someone' was known in the 17<sup>th</sup> century's *Logic of Port Royal*.

displacement, -Lacan developed the formulas of metaphor and metonymy in ‘The Agency of the Letter’, a talk given in 1957, and published first in *La Psychanalyse* no 6, 1960, then in *Écrits* (1966), these were not absolute but approximate equations. Something remained unaccounted. Between the subject ‘represented by a signifier for another signifier’ and what remains unaccounted or unknown there was a relation. Lacan proposed the ‘convergent series’,  $i+1$ , and  $1+a$  in Seminar Book IX (session 10 January 1962). Identification to object  $a$  of desire lead Lacan to reformulate his theory and not simply locate the subject in the gap between two signifiers, but also in the presence or absence of object  $a$ ,  $a+$  and  $-a$ : Lacan chose the theme of Freud’s ‘Three Caskets’(1913f) during the Seminar *Identification*, (lecture 23 January 1962) to explicitly develop the relation of the subject to object  $a$  as a form of identification, in session 24 January 1962. ‘The subject  $\$, 1:A$ , assuming the signification of the Other as such, has the greatest relation with the realization of the alternation  $a+ . a-$ , the product of  $(a+ a)$ , which gives him the formula of the square root of  $-1$ ’ (Seminar Book IX, 24 Jan. 1962). In Seminars Book X, *Anxiety* (1962-1963) and Book XI, *The Four Fundamental Concepts of Psychoanalysis*(1964), Lacan developed the formulas of division between Other and subject via the signifier, followed by a second division, a *refente* of the subject by the object of desire. The signifier is one pole of the subject, the other being something more difficult to define. Chapter 5 of this thesis examines Lacan’s ‘subject’ and identification. Later in Lacan’s teaching,  $(a)$  will be defined as a remainder or surplus *jouissance* (*plus-de jouir*) and this starting from Seminar XVI, *D’un Autre à l’autre* (1968-1969). Freud had a similar term *Lustgewinn*, gain of pleasure introduced in ‘Formulations’(1911b). It had a particular role in perversion (‘Fetishism’, 1927e).

It is true that from the beginning of Lacan's teaching 'the ego' and 'the subject' had distinct functions, were placed on different registers 'The Mirror Stage' (1949) defined the ego (*moi*) as the assumption by the individual of his original chaotic and fragmented existence in the unified body image; it was the matrix of his imaginary identifications to little others; the big Other, *A(Autre)*, was the locus of language and the symbolic, and object *a* of the drive was placed in the real. The subject as unconscious, \$, was situated in the Other, *A*, who was also barred by the signifier leaving a remainder, *a* (see the algorithms of the subject's division in Seminar Book X, *Anxiety*, 1962-1963). Signifier *one* 1, unary trait, was the matrix of all the subject's ideal identifications, namely his ego ideal (Seminar Book VIII, *Transference*, 1960-1961 and Seminar Book IX, *Identification*, 1961-1962). Finally 'one', *Eins*, the signifier of the subject's nomination, was also that 'one' that was once the Thing, *das Ding*. Irreplaceable and lost forever, towards which the subject's identification is destined. Thus, Lacan gave another twist to Freud's aphorism *Wo Es war soll Ich werden* (Lecture XXXI, New Introductory Lectures of Psychoanalysis, 1933a) in his Seminar IX, *Identification* (28 March 1962): *Wo Es war da durch den Eins werde Ich*: the unary trait effaces that one that the Thing once was, that one which I will become'. Thus the Lacanian subject emerges as a complex structure which can only be properly approached through logic, topology and mathematics. The papers of Claude Conté made that quite clear.

One fundamental and early topology of Lacan's subject was presented in the 'Graph of Desire' constructed during Seminars *The Formations of the Unconscious*, Book V (1957-1958) and *Desire and its Interpretation*, Book VI (1958-1959). The gap was shown there

between the level of the subject of the statement, as signifier of the Other,  $s(A)$ , and including the short-circuit of the ego (*moi*) and the subject of the enunciation, signifier of the barred Other,  $S(A \text{ barred})$ , the unconscious, including the short-circuit  $\$ \langle a \rangle$ , the unconscious phantasy. It was the level of desire. In Seminar IX, *Identification* (1961-1962) the graph of desire topologically transformed into a handle extracted from a sphere and becoming a torus. At the lower level the subject received the message: “perhaps, nothing” from the Other, the subject was a possibility, the possibility of a nomination, while to the subject’s question concerning the object of his desire, there was no answer from the barred Other ‘nothing, perhaps’, the Other does not know and wants to know nothing about desire. Thus was for Lacan the subject of psychoanalysis, like Descartes’ subject, a subject who wants to know addressing an Other, who is ‘supposed to know’, but only on the condition of transference love, an Other who finally is proven to know nothing.

#### **D. Chapters 4, 5, 6 and Conclusion**

Unlike Lagache’s presentation of the ‘personality structure’ involving inter-subjectivity and intro-subjectivity, Lacan’s Optical Schema in Chapter 4, involved object  $a$ , although its status was not yet defined. These two presentations are both discussed in their contrasted aspects in Chapter 4.

Chapter 5 argues the progression from the subject’s identification to the signifier, signifier one or ‘unary trait’, Freud’s *ein einziger Zug*, second kind of identification, to the subject’s identification to the desire of the Other, hence to the object of desire, the phallus, in the



third identification. Freud's first identification to the Father as ideal was for Lacan 'the enigmatic identification', deliberately left for development in a later Seminar. The theme of identification to the Father was developed in Seminar Book XXIV, *L'insu que sait de l'une-bévue s'aile à mourre* (1976-1977). The topological surfaces of the torus and the cross-cap were promoted in Seminar Book IX, *Identification* (1961-1962) as the mathemes of *Privation*, *Frustration*, *Castration*, matching with Freud's second and third identifications although not suitable for the first one. After a linguistic reminder of F. de Saussure's theory of the signifier (sessions November, December 1962) and Frege's theory of numbers (February 1962), Lacan focused for a while on the letter and the proper name as the trace of the first identification. His 'conjecture of writing' developed in session 10 January 1962 announces the relation between the letter and the real. Object *a* of desire has a relation to the letter. Lacan's lecture on Freud's 'The Theme of the Three Caskets' (1913f), the 23<sup>d</sup> January 1962, precedes the session of the 24<sup>th</sup> January in which the first formulations of the real appear and its space is shown as a rim on the torus, or as a cut known as the *internal eight* or *double loop* surface, a cut which can be effective on the cross-cap, but not on the torus, an impossible to be constructed in Euclidian space (sessions May and June 1962).

Logically related with the three identifications were the operations of *privation*, *frustration*, *castration*, which Lacan initially presented in Seminar Book IV, *The Object Relations* (1956-1957) using the table of the three modalities of lack *privation*, *frustration*, and *castration*. Those modalities determining the destinies of the Name of the Father and the Oedipus Complex and bringing in the object of desire, were articulated to the three registers

of psychical reality, the Symbolic, the Imaginary and the Real. In Seminar Book IX, *Identification* (1961-1962) a topology was introduced to show the spaces in which such a subject and object evolved. The modalities of *identification* resulted in three modalities of the subject, as symbolic, imaginary, and real. Conté drew attention on that aspect of identification both in ‘Division of the Subject and his Identification’ (1992 [1970]) and in ‘Topological Surfaces’ (1993).

My claim in the second part of the thesis is that the *Real* acquired its first independent status in the algorithms of the subject, and in the logical tables and topological surfaces of Seminar IX, *Identification* (1961-1962), that is before the development of object *a* as object of anxiety in the *Real*, in Seminar Book X, *Anxiety* (1962-1963), and before the logical operations of *alienation* and *separation* necessitating a formal remainder in the *Real*, object *a* of *castration* in Seminar Book XI, *The Four Fundamental Concepts of Psychoanalysis*, 1964. The *Real* was presented first in 1953 in Lacan’s famous intervention before the ‘Rome Congress’ (26 and 27 September 1953). It was a term of the trinity he articulated and formalized for the first time there as ‘symbolic, imaginary and real’ (8 July 1953). But the logical and topological developments of Seminar Book IX (1961-1962) inaugurated the predominance Lacan gave to the Real in his later teaching.

Claude Conté’s insistence on both themes gave the opportunity to name the posthumously published collection of all his papers ‘The Real and the Sexual.’ He said indeed that the Lacanian Field was ‘the field of the Real’. In his paper ‘The Splitting of the Subject and his Identification’ (1970) he made the point of linking splitting and identification, Freud and

Lacan. One of his last contributions in *'L'apport freudien, Elements for an Encyclopedia of Psychoanalysis* (1993), was 'Topological Surfaces', which presented the series of topological surfaces which Lacan used in the 1960s, as mathemes for the transmission of psychoanalysis. Those were namely the single and the intertwined toruses, the cross-cap, the double loop cut, the Moebius strip and the Klein bottle. He concisely developed their structure and their clinical implications. So the different clinical structures were applicable to them, neurosis, psychosis, perversion, but also the operations of interpretation, transference, and the end of analysis. Conté was an analysand and pupil of Lacan, whose major contribution was to present the most complex formulations of Lacan with an original gloss and underlining their significance not only for the clinical practice, but also for training analysis.<sup>11</sup>

**E. The prioritization of 'the Real' by Lacan started two years before Seminar Book XI (1964), disputing the commonly held view.**

The thesis concludes with the claim that the Real is Lacan's true register of the subject starting with Seminar Book IX *Identification* (1961-1962). It is the particular twist which this Seminar gives to the theme of identification. The Real was presented there as a topologically empty space, although, according to his up to then formalizations, the real was full and only the symbolic would bring an opening in the fullness of that space. The symbolic was that of the signifier and the name of the Father, the real was the unreal space

---

<sup>11</sup> It was Conté first who suggested that Freud's *'ego'* would have been better translated as *'I'* (*je*), as was the case with Kant's *'Ich'* in a more recent French translation of the *Critic of Pure Reason* (Pleiad, 1991) He also underlined how rarely Freud's used the German term *'Subjekt'* because of its philosophical origins. (Dorgeuille, C., 'La question du sujet, Conté, C., Débat, 'De la question du sujet à la topologie', *Etudes Freudiennes*, no 33, 199-216, 1992).

of the negative subject. It was opposed to the signifier as ‘that which always comes back in the same place’ (30 May 1962), while the signifier ‘never repeats itself the same.’ The question was not anymore how the signifier entered the real, but how the subject in analysis could come to grasp something of the real, something of the structure, something of him. The real makes a sudden entry in Seminar Book IX, from February 1962 after the first few sessions where identification was defined as the relation of the subject to the signifier. From the signifier Lacan extracted the letter, and there was a particular development of the letter as a trace of the real, as a trace of the subject, shown in the use of the proper name. This led Lacan to the development of his ‘conjecture’, a hypothesis concerning the origins of writing. Then, since the theme of anxiety was discussed in some provincial working days in Spring 1962, Lacan gave a formula of anxiety as ‘anxiety of the desire of the Other’, on which Pierre Aulander built her paper ‘Anxiety and Identification’ which she gave during the Seminar. All roads were leading Lacan to object *a* as the object of desire, the hidden reference of the demand of the subject in his appeal to the Other. He needed topology to show the object in the structure of the subject, because the object was in the real, which is an ‘unreal’ space. But he started first with Logic, Aristotelian Logic and then Peirce’s Logic for the subject is that negative unreal: ‘the subject can be that real with the negative sign of a possible which is not real’ (op. cit. 28 February 1962).

## CHAPTER 1

### DOES THERE-EXIST A SUBJECT IN FREUD?

#### A. The diverse legacy of Freud's 'Project'.

In the 1890s Freud was already deeply involved in the study of the neuroses and in the publication of numerous related papers,<sup>1</sup> while gaining an ever-growing clinical experience. He undertook his first attempt to elaborate a general theory of the psychological apparatus and its functioning. He made several drafts from the spring to the autumn 1895, and finally filled two notebooks in the train coming back from a visit to Fliess, which he soon dispatched to him, his interlocutor, critic and closest friend. Freud referred to the work as his 'Psychology for Neurologists', or simply his 'Psychology', or his *ψω*, and devoted much passion to it. The 'Project for a Scientific Psychology', as it is known in English, was published several years after his death.<sup>2</sup>

In a series of letters sent to Fliess in 1895,<sup>3</sup> Freud described his repeated efforts to

---

<sup>1</sup> Among Freud's papers of the 1890s were: 'On the Psychological Mechanism of Hysterical Phenomena: Preliminary Communication'; appeared in 'Studies on Hysteria' (1895d, S.E., 2, 3), but had already been published as a separate paper (1893a). A shorter version was given by Freud as a Lecture on 11 January 1893 (1893h, S.E. 3, 27). The first paper on 'The Neuro-Psychoses of Defence' was published in 1894 (1894a, S.E. 3, 43), two papers on 'Anxiety Neurosis' in 1895 (1895b, 1895f), and two papers on 'Obsessions and Phobias' the same year (1895c, 1895h). Freud was also communicating his hypotheses on the neuroses in numerous letters and drafts addressed to Wilhelm Fliess, his closest friend and colleague in Berlin. Amongst those letters were the two notebooks of the 'Project'. The whole manuscript of Freud's Letters to Fliess including his Letters, Drafts and the 'Project' were rescued from oblivion by Marie Bonaparte.

<sup>2</sup> The first German publication of the 'Project' saw the light in London, in 1950. It was included in a volume under the title: *Aus den Anfängen der Psychoanalyse* together with a selection of Freud's letters and drafts to Fliess. The title was simply 'Entwurf einer Psychologie', chosen by the editors, Marie Bonaparte, Anna Freud, and Ernst Kris. The English publication appeared in London in 1954, translated by J. Strachey, who added the word 'scientific' to the title. It became: 'A Project for a Scientific Psychology'. 'Extracts from the Fliess Papers' as they were called, were published in one volume as *The Origins of Psychoanalysis*. They were later included in the first volume of the Standard Edition together with other early papers by Freud.

<sup>3</sup> Freud refers to his theoretical endeavour to write the 'Project' in many of his Letters: on April 27, 1895 (he

compose a work which he often found unsatisfactory and of which, according to Ernest Jones, he took a negative view later, almost forgot and wanted to destroy in his old age.<sup>4</sup> In those letters he describes his ambition to introduce ‘quantitative considerations’ in the workings of the psychical functioning: ‘a sort of economics of nerve forces’, and ‘to peel off from psychopathology a gain for normal psychology’.<sup>5</sup> In his brief introduction to the work itself, Freud stated his intention ‘to furnish a psychology which shall be a natural science’,<sup>6</sup> and to account for the ‘excessively intense ideas’, as manifested in ‘pathological clinical observation.’ Using concepts from contemporary Physics, Psychology and Physiology, he devised a structure with three systems, three groups of neurones he calls  $\varphi$ ,  $\psi$ ,  $\omega$ . Neurones ( $N$ ) were ‘the material particles’, which would account for the transmission of ‘neuronal quantity’ ( $Q\eta$ ), of sums of excitations, of psychical energy or stimuli (*Reizen*) and their discharge, which followed the laws of motion and rest, as it happened with the reflex arc. But, the psychical system would be a much more complicated construction.

Freud even made a calculation of the distribution of  $Q\eta$  in the neuronal network, taking

---

is ‘involved in the Psychology for Neurologists’, ‘devoured’ by it, and ‘overworked’); on May 25, 1895 (he talks about his ‘consuming passion’ for the work); on August 6, 1895 (he has reached ‘an understanding of pathological defence’ and other ‘important psychological processes’), on August 16, 1895 (had a ‘queer experience with his  $\varphi\psi\omega$ ... threw it down’). But, on September 23, 1895 (in the train back from his visit to Fliess), he informs him: ‘I begun the summary account of my  $\varphi\psi\omega$  for your criticism’, and promises to ‘test it against the individual facts of the new experimental psychology’. On October 8, 1895: the two notebooks were ‘scribbled’ and sent to Fliess, but he will ‘retain a third dealing with repression’. On November 8, 1895 ‘the whole of the psychology manuscripts went into a drawer’, but on January 1, 1896 a summary revision of his Psychology was sent to Fliess, which appears as Appendix B to the ‘Project’, in Standard Edition (see *Editor’s Introduction to the Project*, S.E. **1**, 283-285 and Masson, J.M (1985), *The Complete Letters of Sigmund Freud to Wilhelm Fliess (1887-1904)*, Harvard University Press, Cambridge Massachusetts).

<sup>4</sup> Jones, E., *Sigmund Freud Life and Work*, Vol. 1, London 1953, Chapter XIII, 316-318, and *Editor’s Introduction to the Project*, S.E. **1**, 290.

<sup>5</sup> Freud, S., Letter May 25, 1895, in: Masson, J.M., op. cit., 129.

<sup>6</sup> Freud, S., (1950a [1895]), S.E. **1**, 295. Freud’s statement of intention encouraged many to consider the work a physiological psychology.

into account the complications of transmission in the ‘facilitations’, or better connecting paths (*Bahnungen*) and the neuronal contact-barriers (*Kontaktshränke*), the equivalent of what was later called ‘synapses’. Freud proposed a logarithm of transmission ‘reminiscent of Fechner’s law’.<sup>7</sup> Thus, he used mathematical formalisations in his ‘psychology’, which he did not exclusively cast in physiological or neurological terms.<sup>8</sup> Jones however believed that the ‘Project’ was Freud’s attempt to construct a physiological psychology.<sup>9</sup> In his biography of Freud he considered the work as particularly influenced by S. Exner’s *Entwurf zu einer physiologischen Erklärung der psychischen Erscheinungen* (1894) and Jones’ opinion echoed in the title of the work for its German publication: ‘*Entwurf einer Psychologie*.<sup>10</sup> Jones referred to the ‘Helmholz-Brücke School . . . powerfully reinforced by Meynert,’ as a major influence

<sup>7</sup> Fechner’s law expressed the relation between changes in the strength of stimuli and changes in the ensuing sensations, so that ‘sensation varies with the logarithm of the strength of the stimulus.’ Freud, who needs to account for the clinical realities of resistances, inhibition, and repression and their ‘quantitative’ implications, modifies Fechner’s formula. Freud’s formula states that *quantity* in  $\phi$  is expressed by *complication* in  $\psi$ . Thus, a stronger stimulus follows a different path than a weaker one: 3 ( $Q\eta$ ) in  $\phi$  becomes  $\psi_1, \psi_2, \psi_3$  or 3( $Q\eta$ ) in  $\phi$  is not the same quantity as  $Q\eta_1, Q\eta_2$  or  $Q\eta_3$  in  $\psi$  (op. cit., 315, n. [2]). Fechner’s law was formulated in terms of stability of psychophysical quantity in the organism. It became known as ‘constancy law’. Freud related it to his own ‘pleasure principle’: ‘pleasure and un-pleasure [relate] to the quantity of excitation that is present in the mind but is not in any way “bound”... and... relate to them in such a manner that un-pleasure corresponds to an increase in the quantity of excitation and pleasure to a diminution ...’ But, for Freud, this is not a simple relation between quantity of excitation and strength of feeling. It has to do with ‘excitation in a given period of time.’ (Freud, S., 1920g, S.E. 18, 8).

<sup>8</sup> Freud argued early on that the primary trend of the organism towards *inertia* was identical to the psychical trend of ‘avoiding unpleasure’ (1950a, S.E. 1, 312). The rise of quantity in  $\psi$  would translate into the sensation of unpleasure in  $\omega$ . The middle zone of indifference or ‘neuronic inertia’ would correspond to Fechner’s ‘principle of constancy’, as he stated clearly in ‘Beyond the Pleasure Principle’ (1920g): ‘the pleasure principle follows from the principle of constancy’ (op. cit., S.E. 18, 9). When, in that work, Freud adopted Barbara Low’s (1920) ‘Nirvana principle’, he related it to his pleasure principle. However, this is arguable as its further discussion in ‘The Economic Problem of Masochism’ shows ((1924c, S.E. 18, 55-56, and n. [1]).

<sup>9</sup> In his *S. Freud, Life and Work* (1953, chapter XVII, 400-444), Jones points out that Freud was in favour of the ‘psycho-physical parallelism’ of Hughlings Jackson, and had even suggested in his early work *On Aphasia*, (1891b) the precedence of physiological processes over the psychical ones. But, the ‘Project’ was a different work altogether, in which a psychical apparatus was constructed, a mechanism in which desire was predominant, and remembrance, repetition, resistance, and defence, in relation to the return of the state of desire as seen from clinical observation, pointed at the presence of a subject.

<sup>10</sup> Exner, S., *Entwurf zu einer physiologischen Erklärung der psychischen Erscheinungen*, was published in Vienna in 1894. Exner was Brücke’s successor as professor of Physiology and Jones suspects him to be ‘an important immediate stimulus’ on Freud’s ‘Project’.

on the 'Project'. A crucial influence on Jones was the two papers by Siegfried Bernfeld.<sup>11</sup> Strachey's approach was similar to Jones', although he found in the 'Project': 'the premises of some of Freud's later meta-psychological developments.'<sup>12</sup>

In their paper 'A Problem of Scientific Influence' (1988), Burgoyne and Leader demonstrated how, with Bernfeld, Jones and Strachey, a tradition was established which limited Freud's scientific ambition to the influences of Physiology and Neurology. Bernfeld first referred to 'the Helmholtz School of medicine' and its 'materialistic programme', while no such 'School' really existed. Prominence was given to S. Exner's *Entwurf* (1894) as a 'stimulus' for Freud's 'Project', as we already said. This approach 'obscured the problem of the nature of science and in particular the variety of the scientific programmes adopted by Freud and their possible coherence', as the authors of the 1988 paper argued.<sup>13</sup> The 'Project's philosophical and mathematical aspirations were overlooked, although both philosophy and mathematics had a big impact on German psychology in the 19<sup>th</sup> century.<sup>14</sup> While Jones attributed the concept of psychical quantity to Breuer via the Helmholtz – Brücke -Meynert School, researchers such as Louise von Karpinska (1914), and especially Maria Dorer (1932), demonstrated that this was a concept first introduced in Psychology by

---

<sup>11</sup> The two articles by Bernfeld were: 'Freud's Earlier Theories and the School of Helmholtz', in *Psychoanalytic Quarterly*, Vol. 13, 1944, and 'Freud's Scientific Beginnings', in *American Imago*, Vol. 6, 1949. In his book *Freud Biologist of the Mind* (New York, 1979), Frank Sulloway went so far in that direction, as to argue that the 'Project' was 'a regressive step, a biological explanation of the mind, which was disavowed and discarded by Freud himself.'

<sup>12</sup> J. Strachey's 1954 'Introduction to the Project', S.E. 1, 290: 'The 'Project', in spite of being ostensibly a neurological document, contains within itself the nucleus of a great part of Freud's later psychological theories'.

<sup>13</sup> Burgoyne, B. & Leader, D., 'A Problem of Scientific Influence', in *Newsletter of the Centre for Freudian Analysis and Research*, No. 13, 1988, London.

<sup>14</sup> The influences of Leibniz on Herbart, of Locke, or even Kant and Galileo on Helmholtz were but a few examples of the impact of philosophy on German Psychology. Herman von Helmholtz referred to Locke as 'the authority on the relation between our corporeal and mental make-up' (Op. cit. p.16).



Johann Friedrich Herbart.<sup>15</sup> Terms such as ‘repression’, ‘threshold of consciousness’, and ‘the generation of a field of forces from the conflictual interaction of mental representations’ were Herbartian concepts, some of them found in Freud himself.

The authors also underlined the importance of Fridolin Volkman von Volkmar, another German psychologist whose works saw many publications in 1894 and 1895. They may have been the source of Freud’s knowledge of Herbartian psychology.<sup>16</sup> Volkman von Volkmar had also attended -like Freud- Brentano’s lectures on Logic and Aristotle.<sup>17</sup> The term ‘desire’ (*Begierde*), which the physiological and neurological readings of the ‘Project’ ignored, was ‘ubiquitous’ in Volkman von Volkmar’s work.

In his doctoral thesis on Freud’s ‘Project’<sup>18</sup> Filip Geerardyn considered ‘the very conceptual frame’ of the work as the origin of its many misunderstandings. Concepts such as ‘energy’, ‘discharge’, and others were borrowed from 19<sup>th</sup> C. physics, but, as the author argued in his thesis, despite those mechanistic, hydraulic, or electrical concepts, Freud wanted to develop ‘a clinical psychology’, and to account for the ‘excessively intense

---

<sup>15</sup> The importance of 19<sup>th</sup> century German Psychologist Johann Friedrich Herbart was largely ignored by early commentators of the ‘Project’. As the authors of the 1988 paper argued, Freud could have accessed Herbart’s work either through the works of German psychiatrist W. Griesinger, or through his teacher, T. Meynert. He may also have had firsthand knowledge of Herbart’s most famous work: *Psychologie als Wissenschaft*, first published in 1824, then reprinted in 1886, in his *Sämtliche Werke*. Herbart ‘first introduced the idea that the structure of the mind underlying the qualities of experience is amenable to the language of Mathematics’. (Op. cit., 10).

<sup>16</sup> The mathematicians Bernhard Riemann and the psychologist Volkman von Volkmar both used Herbart’s ideas; Riemann borrowed the concept of representations (*Vorstellungen*) from Herbart and talked about psychical masses in the soul ‘governed by a herbartian calculus’. Volkman von Volkmar borrowed his programme on desire from the same Herbart. (Op. cit., 11-12).

<sup>17</sup> According to Jones Biography of Freud (1953, Vol. 1), Freud attended Brentano’s Lectures on the History of Philosophy, on Logic in 1875 and on Aristotle from 1876 onwards. Lacan thinks that it was in 1887 that Freud attended Brentano’s Lectures on Aristotle, especially the *Nicomachean Ethics*. (Lacan, J., 1959-1960, *The Ethics of Psychoanalysis*, Nov. 25, 1959, Seminar Book VII, 1992, Routledge, 30).

<sup>18</sup> Filip Geerardyn’s thesis was published in Ghent, 1993 by Idesça, and translated in English in 1997 as: *Freud’s Project, On the Roots of Psychoanalysis*. It was published in 1997 by Rebus Press, London.

ideas', the affects which he had already observed in hysteria. Geerardyn took Freud's neuronal quantity ' $Qn$ ' as another name for 'the sexual affect', a term we find in the 'Studies on Hysteria' (1895d), and not only in the theoretical part written by Breuer. It had been introduced earlier by Freud himself, first in the 'Preliminary Communication' (1893) and later in the Letter of May 21, 1894.<sup>19</sup> Geerardyn underlined the existence of a gap between the excessively intense idea and the affect, and pointed out their false connection, which Freud showed with his famous clinical vignette in Part II of the 'Project', called 'The Hysterical Proton Pseudos.'<sup>20</sup> The emphasis on 'desire'<sup>21</sup> and the 'sexual affect'<sup>22</sup> changed more recent research.

In his first commentary on Freud's 'Project' in Seminar Book II, *The Ego in Freud's Theory and in the Technique of Psychoanalysis* (1954-1955), Lacan revealed the importance of Freud's construction of the psychical apparatus in the 'Project', and of the

---

<sup>19</sup> A definition of the 'sexual affects' and their role in the genesis of the neuroses we find in Letter of May 21, 1894 where we read: 'Sexual affect is of course taken in its broadest sense as an excitation having a definite quantity' (Masson, J.M., op. cit., 75). Sexual excitation and affect are taken almost as synonymous, and are at the origin of the neuroses. The so-called sexual affect is further specified as a physical sexual tension, which 'above a certain value arouses psychic libido' but, 'if the specific reaction[sexual act] fails to ensue, the physico-psychic tension (*sexual affect*) can be transformed into anxiety, for example in anxiety neurosis where the aforesaid tension fails to transform into psychic libido or psychic affect, contrarily to hysteria, (Draft E, 'How Anxiety originates', undated, [envelope of June 6, 1894, in Masson, J. M., op. cit., 80-81).

<sup>20</sup> Freud, S, (1950a[1895]), S.E. **1**, 352-356.

<sup>21</sup> Burgoyne B. & Leader D. underline that *Begierde* is not 'craving', as Strachey translated, but desire. It can also mean appetite or tension according to Lacan who suggests that what Freud indicated there was a special tension, the tension between the unifying mirror image and the disparate, disconnected desires of the subject (Lacan, J., 1954-1955, Seminar Book II, *The Ego in Freud's Theory and in the Technique of Psychoanalysis*, 1988, p. 50. Freud, S., *Aus den Anfängen der Psychoanalyse*, 440: '*Im Ich herrscht die Begierdespannung in deren Folge die Vorstellung des geliebten Objektes . . . besetzt wird*'. In the 'ego' prevails the tension of desire following which the representation of the beloved object will be cathected [my translation].

<sup>22</sup> In the 'Project', it is predominantly the experience of pain which is defined as *affect*, and pain is an accumulation of excitation, an increase of  $Q$  in  $\phi$  which erupts in  $\psi$ . Pain is then felt as un-pleasure in  $\omega$ . The state of desire (*Wunschzustand*), which derives from the representation of a past experience of satisfaction can lead to unpleasure too, as the state of desire can also cause the rising of psychological tension, of  $Q\eta$  tension in  $\psi$ . The experiences of pain and satisfaction leave residues which are 'affects' more generally, resulting either in a positive attraction to an external friendly object or in a defence (*repression*) against a hostile memory or object. They leave behind 'permanent motives of a compulsive kind' (Freud, S., (1950a [1895]), S.E. **1**, 322). He further adds: 'Both wishful cathexis and release of unpleasure, where the memory in question is cathected anew, can be biologically detrimental' (Freud, S., *Ibid.*, 325).

theoretical tools he used, and especially of the energy paradigm as the epitome of the science of his time, Physics. Such concepts, he said, were necessary for psychoanalysis if it wanted to be a science. But, these ‘hydraulics of desire, mechanics of defence, and currents of transmission’ also pointed at a different ‘reality’, the symbolic and imaginary reality. Lacan translated the two laws of thermodynamics of the 19<sup>th</sup> century in terms of 20<sup>th</sup> century cybernetics, and the hydraulic factory to the invention of another sort of machine, a machine with which we can communicate, ‘and do all sorts of computations’. Cybernetics together with linguistics and mathematics can both provide the tools to formalize psychoanalysis in our time. Thus Lacan compared the ‘ $\psi$  paths of transmission of neuronal excitation’, with the articulations of the signifying network.<sup>23</sup> Like the signifiers, neurones  $\psi$  were distinct, but articulated elements. If they are filled with Quantity ( $Q\eta$ ), Lacan, like Freud, made this the result of a mathematical computation, rather than the outcome of raw energy.

Freud placed in  $\psi$  the special group of neurones which he called *ego*. He defined it either as ‘the totality of the  $\psi$  cathexes at the given time’ with ‘a permanent and a changing component’, or as its core.<sup>24</sup> ‘Ego’ (*Ich*) was constantly cathected with psychical tension which it used for inhibition. ‘Facilitation’ (discharge) and inhibition were its two functions. Lacan proposed the category of the imaginary to place Freud’s ego in the ‘Project’. He, moreover, asked: is this area of the ego as a buffer system of constancy and symmetry the only parameter in the psychical apparatus? As we know, Freud was forced to insert a third parameter, a group called  $\omega$ . He considered it as related to consciousness, a test for the

---

<sup>23</sup> Lacan, J., *The Ethics of Psychoanalysis*, Seminar Book VII, 1959-1960, December 2, 1959.

<sup>24</sup> The facilitations are part of the ego’s possessions. Freud, S., (1950a [1895]), op. cit., 323.

reality of psychical stimuli, and helping through verbal articulations the perception-consciousness system which lied next to memory and hallucination. The  $\varphi\psi\omega$  systems were however mere symbols, as he said. But, if energy was evacuated in that way, how do we explain desire and repetition? <sup>25</sup>

Lacan concluded his presentation of the 'Project' in Seminar II considering Freud's *ego* as a symbol within the world of symbols. But, he also divested it of its symbolic status, as Freud did, and made it an object of libido, like any other object. It is, as he said, 'both the unifying mirror image and the fragmented paralytic led by a blind man, as in the mediaeval imagery'. <sup>26</sup> A few years later, in his Seminar *The Ethics of Psychoanalysis* (1959-1960), Seminar Book VII, Lacan read the 'Project', as a work having more to do with ethics and desire, than with physiology or biology. <sup>27</sup>

In his research on Freud's psychical apparatus, J. G. Bursztein (1999) considered that we need to take the concept of neuronal quantity ( $Qn$ ) literally. He suggested that the signifying elements can be compared to material quanta of energy, and not simply functioning as metaphors and metonymies.  $Q$  is a quantum of energy and a symbol. It is in a minimum formalization for the psychical experience in the neuroses. <sup>28</sup> Freud's

---

<sup>25</sup> When Lacan, in his Seminar *The Ego in Freud's Theory and in the Technique of Psychoanalysis* (1954-1955), first reads the *Entwurf* ('Project'), he discerns symbolic and imaginary in Freud's *Ich*, but notes that the imaginary, although it must be implied, is lacking as a category (Lacan, J., 1954-1955, op. cit., Seminar Book II, chapter IX, 2 February 1955, p. 108). He compares the psychical apparatus to a machine or rather to a computer where energy is transformed into symbols, and the function is articulation and discharge. Thus, the  $\varphi\psi\omega$  is 'a play of writing', a formal apparatus, in which Freud faces the difficulty of resolving the question of repetition and insistence in the desiring state. (See as well op. cit., chapters IV, V, VII, VIII).

<sup>26</sup> Lacan, J., 1954-1955, op. cit. Seminar Book II, Chapter 50-52.

<sup>27</sup> In 'Beyond the Pleasure Principle' (1920g) Freud went back to the questions he raised in the 'Project'. In *The Ethics of Psychoanalysis* (Seminar Book VII, 1959-60), Lacan called the system  $\varphi\psi\omega$  'Freud's 'first topography of subjectivity'. He treated it not only on the level of the insistence of desire, and of the ego, with its symbolic, and imaginary implications, but also on the level of the real, and of the moral law.

<sup>28</sup> Bursztein, J-G., *Qu'est-ce que l'appareil psychique?*, Nouvelles Etudes Freudiennes, Paris, 1999.

introductory statement to the work seems to corroborate this assumption:

‘The intention is to furnish a psychology that shall be a natural science: that is to represent psychical processes as quantitatively determinate states of specifiable material particles, thus making those processes perspicuous and free from contradiction.’<sup>29</sup>

Neither physics, nor biology of the mind, Freud’s ‘Project’ was his first attempt to formalize his nascent psychoanalytic theory. To do this Freud had to translate sexual excitation and defensive processes into a scientific theory appropriate to handle the problems met in the clinical experience of the neuroses. The system he devised made of ‘material particles’, of articulated neurones ( $N$ ), had also to account for quantities of excitations ( $Q\eta$ ), alias affects accounting for the subject’s experiences of hallucinatory satisfaction, and pain ( $\phi$ ). Those were transmitted to ( $\psi$ ) as memories, they became the subject’s activities of remembering and repeating, of thought, of judging and of discerning ( $\omega$ ). Constancy and homeostasis were also functions of the apparatus. Freud had particularly to answer the question how in this apparatus, neurones ( $N$ ) filled with quantity ( $Q\eta$ ) could account for perception, memory, and representation, which were qualitative phenomena. The answer was  $\omega$  neurones, the consideration of the function of language. As Freud concluded, language made judgement and cognition of the unconscious representations possible.

In this respect, the whole apparatus was a symbolic construction, in which the experiences of satisfaction and/or pain affect a being, subjected to the repetition of the state of desire in order to ‘find again’ the object linked with the first experiences. For that he must be helped by a ‘resourceful outsider’. This realisation is achieved through

---

<sup>29</sup> Freud, S., (1950a [1895]), S.E. **1**, 295.

language.

In his Seminar Book II, *The Ego in Freud's Theory and in the Technique of Psychoanalysis* (1954-55), Lacan underlined the modern paradigm of the computer and the science of Cybernetics to denote the combinative of the signifier, to show the logic of the subject. He constructed graphs, he used logic and the intuitive, constructions of topological surfaces to show the structure of the subject and its strategies of 'finding the object again'. But, as he pointed out, and as Freud showed already in the 'Project', the system dealing cleverly with the transmission of excitation and the defensive strategies leaves a gap, in which the effects of something, Lacan will later call the real, cannot be counteracted. As Freud said, 'if this is so', if in the interior of the organism ' $\psi$  is exposed to  $Q$ s ... without protection ... in this fact lies the *mainspring* of the psychical mechanism.'<sup>30</sup> By the term *Trieb* or *Triebfedern*, or even by what Freud called 'the will' (*das Will*), the *drive*, first appeared in the 'Project'

## B. The principle of 'inertia'

Freud talked in the 'Project' about the primary 'trend' of *inertia* in the psychical apparatus. It operates in the middle area between pleasure and unpleasure and allows sensory qualities to be perceived. The adoption of Fechner's 'principle of constancy' by Freud as 'neuronic inertia' is referred to by Breuer in the theoretical part he wrote for

---

<sup>30</sup> Freud, S., (1950a [1895]), S.E., **1**, 315-316. *Triebfedern* is the term used by Freud, 'springs of the drive'. And he adds further: 'Here [in the nuclear neurones],  $\psi$  is at the mercy of  $Q$  and it is thus that in the interior of the system there arises the impulsion (*Antrieb*), which sustains all psychical activity. We know this power as the will -the derivative of the drives' (op. cit. 317 and n.2).

the *Studies on Hysteria* (1895d).<sup>31</sup> But, while Breuer was discussing quantity as ‘energy’ fluctuating in the brain in the form of either hydraulic or electrical tension, already an old idea (Cabanis, 1824) Freud was introducing sexual determination, the ‘different sexual factors’ as the cause of the neuroses.<sup>32</sup> In Part II of the ‘Project’, the symptom is a symbolic determination traced back to the subject’s sexual and ‘excessively intense ideas’, and takes the place of ‘the *thing* entirely’, although motion ( $Q\eta$ ) is always required for symbol formation. Part I of the ‘Project’, deals at the end with the activity of dreams, and has a snippet of Freud’s dream known as ‘Irma’s injection’. It is an example of the connexion between unconscious ideas, and sexuality, articulated on the basis of the paradigm of the neuronal paths of transmission described earlier. In the beginning of the ‘Project’, Freud described the processes in the neuroses, where ‘excessively intense ideas were concerned’, as ‘stimulus, substitution, conversion and discharge’, thus ‘directly suggesting the conception of neuronal excitation as ‘quantity in a state of flow.’<sup>33</sup> We saw that these excessively intense ideas were related to those ‘sexual factors’ mentioned earlier in the ‘Studies’ (1895d).

Freud used letter  $Q$  and in particular invented  $Q\eta$  (neuronal quantity) for the sexual excitation (intensity and motion of), and letter  $N$ , as the symbol for the neuronal network, the material particles through which the excitation would be transferred as

---

<sup>31</sup> Breuer, J., and Freud, S., *Studies on Hysteria*, (1895d), Part III, S.E. 2, 197. Breuer distinguished the ‘potential energy’ of the nervous cells, from the ‘kinetic energy’ of the nervous fibres and the quiescent state of nervous excitation, or nervous tension (ibid., 194).

<sup>32</sup> The sexual aetiology of the neuroses had already been formulated by Freud in the first paper on ‘The Neuro-Psychoses of Defence’ (1894a) and in the first paper on anxiety neurosis (‘On the Grounds for Detaching a Particular Syndrome from Neurasthenia under the Description “Anxiety Neurosis”’) (1895b).

<sup>33</sup> Freud, S., (1950a [1895]), op. cit., 296.

information. It is the minimum of formalism he needs. <sup>34</sup> The first principle of functioning of this apparatus, its ‘first principal theorem’, is the ‘principle of inertia’:

‘The principle of *inertia* explains the structural dichotomy [of neurones] into motor and sensory as a contrivance for neutralizing the reception of  $Q\eta$  by giving it off . . . A primary nervous system makes use of this  $Q\eta$  which it has thus acquired, by giving it off through a connecting path to the muscular mechanism . . . This discharge represents the primary function of the nervous system.’<sup>35</sup>

While the primary function of the nervous system is ‘complete discharge’, the secondary function serves a slightly different purpose, which is to keep quantity ‘constant’.<sup>36</sup> This new function allows the choice of paths ‘which involve a cessation of the stimulus.’ For that reason, quantity is not all given off, a small amount has been retained, and equilibrium is established between the quantity of excitation and the quantity needed to avoid it. Thus the inertia principle is not upset.

At the end of the process of excitation total discharge should be achieved, ideally quantity should be brought back to zero. This is what corresponds to the reflex movement. But, in the psychical functioning, something still remains, a ‘causal gap’. As Freud underlines, the principle of inertia was broken through, almost from the start, due

---

<sup>34</sup> In his first paper on ‘The Neuro-Psychoses of Defence’ (1894a), Freud had already expressed the idea : ‘that in mental functions something had to be distinguished - a quota of affect or sum of excitation - which possesses all the characteristics of quantity . . . which is capable of increase, diminution, displacement and discharge . . .’ (Freud, S., 1894a, S.E. 3, 60). His idea of cathexis (*Besetzung*) was based on that.

<sup>35</sup> Freud, S., 1950a [1895], S.E. 1, 316. Fechner’s law of constancy was the inspiration of Freud here, and Freud used it to develop his pleasure principle. As Strachey notes, the term ‘pleasure principle’ had not been used in the ‘Project’, but the idea was fully developed. As Freud says ‘there is a trend in psychical life of avoiding unpleasure’ (op. cit., S.E. 1, 312). However, complete discharge is not the same as constancy. The former aspect awaits further development in ‘Beyond the pleasure principle’.

<sup>36</sup> Like Freud, Fechner was a follower of the psycho-physiological parallelism of J. Hughlings Jackson. He had also been influenced by Herbart. Fechner’s *Elemente der Psychophysik*, published in 1860, were built upon Herbartian premises. Like Herbart, Fechner talked of topographical thresholds, of intensities and of repression in the unconscious processes, but, as Jones notes, he did not recognize the latter as psychical phenomena.



to another circumstance, with very important consequences. This circumstance arose under the pressure of what Freud calls: *das Not des Lebens*,<sup>37</sup> life's want. He does not use the term *Bedürfnis*, need. It is stronger than that. Strachey translates it as 'urgency', or as 'the exigencies of life'. There are three mentioned by Freud here: hunger, respiration, and sexuality. They 'have their origin in the body's cells' and subject the organism to 'endogenous excitations' (*endogene Reizen*) from which there is no possible flight:<sup>38</sup> This calls for discharge through internal change (screaming, emotions), and this path of internal discharge 'acquires a secondary function of the highest importance, that of *communication*' to an outsider. What is needed is '*fremde Hilfe*', through *specific action* (*spezifische Aktion*) accomplished by an experienced individual (*ein erfahrenes Individuum*), independently of endogenous  $Q\eta$ . With this helpful person's (*hilfreiche Person*) assistance, the specific action will bring an end to the excitation thanks to the experience of satisfaction. Further on in the 'Project', Freud expands on the experience of satisfaction and qualifies 'the initial human helplessness as the *primal source* of all moral motives'.<sup>39</sup>

---

<sup>37</sup> Ibid., 297. The German-English Langenscheidt Dictionary translates *das Not* as: want, misery, necessity, trouble and distress. In 'The Interpretation of Dreams' (1900a), Freud chose the Greek term *Ανάγκη* to express a similar idea. *Ananke* is a force against which even the gods can do nothing. In Aristotle, it is a philosophical concept, which means 'logical necessity' or 'law'.

<sup>38</sup> The fact that, in the internal paths of conduction,  $\psi$  is at the mercy of  $Q$ , is thus the cause of all psychical activity: 'Here  $\psi$  is at the mercy of  $Q$ , and it is thus that in the interior of the system there arises the *impulsion* (*Antrieb*) which sustains all psychical activity. We know this power as the *will* - the derivative of the drives' (op. cit., S.E. 1, 317. Endogenous excitations seem to be the precursors of the drives. They are processes 'of an intercellular nature ... arise continuously and... only periodically become psychical stimuli' (ibid., 316). There is an 'accumulation' of  $Q$  in the internal paths which has a psychical effect. It is called *summation*. The paths are made of several segments with a number of contact-barriers interpolated between them and up to the  $\psi$  nucleus. Above a certain  $Q$  they act continuously, otherwise it is their *period*, which will be registered in the  $\omega$  neurones and translated either as unpleasure, when the cathexis is stronger, or as pleasure, when it is weaker (ibid., 310-316). They fill  $\psi$  and make them at the end permeable. Freud is aware of contradicting himself here, as  $\psi$  neurones continue to 'maintain a position between permeability and non- permeability' (ibid., 316-17).

<sup>39</sup> Ibid., 318. The German '... *die anfängliche Hilflosigkeit des Menschen ist die Urquelle aller moralischen Motiven*' (*Aus den Anfängen der Psychoanalyse*), (Freud, S., 1950a [1897-1902]), 402.

Freud's intuition of 'contact barriers' (*Kontaktschränken*) and of their role in the conduction of excitation through the neuronal paths (*Bahnungen*), is an original and sustainable hypothesis confirmed by the discovery of the synapses two years later. Although the anatomy of the nervous system was known, the functioning was not. Now in addition to the neurone's structure of a cell/dendritis, and an axis/cylinder, there is a foreign substance through which neurones communicate. This foreign substance, which Freud intuited as the 'contact –barriers' was discovered in neuroscience in 1897 by C. S. Sherrington and M. Foster who coined the since established term of 'synapses'. Freud's theory of the functioning of contact-barriers and their facilitations has an important psychological use, as it allows him to formulate a psychoanalytic theory of memory, and to explain resistance. Freud who constructed the psychical apparatus on the paradigm of a single neurone, gives us a model of the whole nervous system in two parts: First, the *cathected* neurone, *N*, 'filled with a certain  $Q\eta$ , while at other times it may be empty,' second, 'a current passing through the cell's paths of conduction or processes [dendrites] to the axis-cylinder.'  $Q$  is transferred between neurones through the contact-barriers and is discharged in the axis-cylinder. But, on the other hand, an accumulation of  $Q$  is possible thanks to the resistances of the contact-barriers. Thus complex psychological phenomena already observed in the clinic, are formalized in the structure of the psychical apparatus.<sup>40</sup>

'The principle of inertia finds its expression in the hypothesis of a current passing from the cell's paths of conduction or processes [dendrites] to the axis-cylinder. A single neurone is thus a model of the whole nervous system with its dichotomy of structure, the axis-cylinder being the organ of discharge'.<sup>41</sup>

Interestingly, Freud uses the term 'transference' to qualify the passage of  $Q\eta$  through

---

<sup>40</sup> Freud, S., (1950a [1895]), S.E. 1, 298. Strachey argued that the term *cathexis* (*Besetzung*), together with terms such as the *principle of inertia* or *constancy*, were initially conceived as physiological explanations, and only later became psychological concepts. The problem with that argument is that it postulates a 'physiological psychology' in the 'Project', while 'psychoanalytic theory' proper would start only with 'The Interpretation of Dreams' (in Strachey's Appendix to 'The Neuro-psychoses of Defence: The emergence of Freud's fundamental hypotheses', (Freud, S., 1894a, S.E. 3, 62-5).

<sup>41</sup> Freud, S., (1950a[1895]), op. cit. 298.

the neurones. He notes that next to transference of  $Q\eta$ , the passage of  $Q$  through the neurones has another characteristic, which is temporal and is called a *period*. It operates already in external stimuli, whose transmission is first reduced in quantity, then, only certain *periods* of neuronal motion are allowed through. This influences their *quality*.

‘Screens and sieves’:

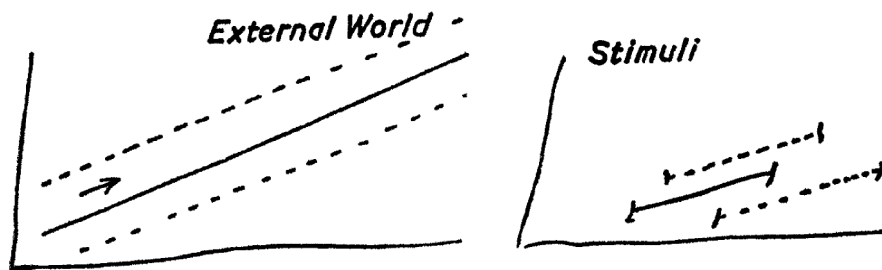

[Fig. 12] Freud, S., (1950)[1895], S.E., 1, 313

From the interior of the body, on the other hand, the internal stimuli are transmitted continuously. This gives a monotonous quality to  $\psi$  neurones, while  $\omega$  appropriate only the period of their excitation. There, according to Freud, ‘the fundamental basis of consciousness lies’.<sup>42</sup>

<sup>42</sup> Freud initially regarded the psychological processes ‘as something that could dispense with consciousness’ (Freud, S., 1950a, op. cit., 308). Now he is forced to put consciousness back into the system, to account for the quality of sensations, for pleasure, and unpleasure as well. Initially both  $\varphi$  and  $\psi$  were operating during perception, but  $\psi$  was exclusively in charge of remembering. Both were quantitative processes only. He now needs to invent another group of neurones,  $\omega$ , the neurones of consciousness, operating along perception, but not along remembering. He will also introduce the idea of the *period* of excitation being translated into *quality* in  $\omega$ , excitation coming not only from external, but also from internal stimuli. Thus ‘. . . all the resistance of the contact-barriers applies only to the *transference* of  $Q$ , but . . . the period of the neuronal motion is transmitted without inhibition in all directions, as though it were a process of induction’ (op. cit., 310; 313, [Figure 12] above). The  $Q\eta$  in the  $\omega$  neurones is tiny. ‘The  $\omega$  neurones behave like organs of

Next to discharge, there is a secondary function calling for the accumulation of  $Q\eta$ .<sup>43</sup> It is another function of the contact-barriers, which can become real barriers and not only connecting paths. Freud can thus account for the clinical fact of resistances. The characteristics of contact-barriers create ‘a differentiation in the protoplasm’ and improved ‘conductive capacity’. Thus, two sorts of neurones are created, those which remain unaltered after the passage of an excitation, ready to receive new excitations and those which are permanently altered. This is a new hypothesis, stating that neurones become either ‘permeable, - offering no resistance and retaining nothing - or ‘impermeable’ - loaded with resistance and holding back  $Q\eta$ ’. The latter are ‘the vehicles of memory and so probably of psychological processes in general’.<sup>44</sup> Freud will reserve the function of memory to neurones  $\psi$  and of perception to neurones  $\phi$ , as retaining nothing. But, as we know that there is ‘re-learning (*Übererlernen*) on the basis of memory’, repetition [of  $Q\eta$  passage] must lead to the contact-barriers becoming less impermeable in the  $\psi$  neurones too. The system then becomes totally facilitated. Only the differences in the facilitations count for memory, ‘memory is represented by the differences in the facilitations between the  $\psi$  neurones’, as Freud underlines.<sup>45</sup> Finally the paths facilitate complete discharge and come to ‘serve the primary function’.<sup>46</sup> Freud’s argument of  $Q$  and facilitations has a mathematical calculation.<sup>47</sup>

---

perception, and in them we could find no place for a memory’ (ibid.).

<sup>43</sup> Freud, S., Op. cit., 298.

<sup>44</sup> Ibid., 300.

<sup>45</sup>  $Q\eta$  and number of repetitions, ‘quantity plus facilitation’ determine the function of memory (ibid.).

<sup>46</sup> First,  $\psi$  had to store  $Q\eta$  to face the demands made by the exigencies of life, second it had to discharge it (op. cit., 301). A quotient remains as permanent facilitation.

<sup>47</sup> Freud will use a formula similar to Fechner’s law to account for the facilitations and complications in the apparatus (op. cit., 315).

Freud's theory of the contact-barriers offers many possibilities. *Bahnungen*, the paths or tracks opened through the contact-barriers, are the result of the interplay of forces between quantities crossing and/or quantities stored. In the construction of a psychical apparatus, which needs to explain both the retention of  $Q\eta$ , for memory and resistance,<sup>48</sup> and the flow of quantity, for the transference of information, the hypothesis of the contact-barriers will provide exactly that. Contact-barriers further induce a functional -if not structural- differentiation, two sorts of neurones, which Freud named with two Greek letters,  $\phi$  – from 'physiological' – for the perceptual neurones, and  $\psi$  – from 'psychical' – the *mnemic*, impermeable neurones. Freud is not interested in the physiology of the neuronal systems, but in their capability to serve not so much as the material base but as the metaphor for the structure, topography and function of the psychical apparatus. Thus, systems  $\phi$  and  $\psi$  are not the equivalent of the grey matter of the spinal cord, and of the grey matter of the brain, the first receiving only external stimuli with the second receiving only internal stimuli. As Freud points out, if his theory amounted simply to this anatomical localization, he 'should not have invented the two classes,  $\phi$  and  $\psi$ , he should simply found them already in existence',<sup>49</sup>  $\psi$  would just be satisfying the functions of the primary brain: 'The primary brain fits pretty well with our characterization of the system  $\psi$ ', and the primary brain, as Freud adds,

---

<sup>48</sup> To explain the contradiction of the  $\psi$  neurones being able to become permanently facilitated, but recover their non- permeability, almost completely, after the passage of an excitation, Freud uses the mathematical calculations which will lead him to his own law of constancy:  $Q:3\eta$  once is not equivalent to  $3xQ\eta$ : 'Possibly only a quotient of it [ $Q\eta$ ] is left as *permanent facilitation*' (op. cit., 302), and this would explain resistance. After the passage of  $Q\eta$  in the contact barriers, what happens is not an abolition but a reduction of resistance to a minimum. After the passage of  $Q\eta$ , resistance is reinstated in various heights, and thus always smaller quantities will pass through. This resistance is a constant. In the internal paths of conduction, on the other hand, endogenous  $Q\eta$  which is less than the constant, operates by *summation* which means that after a certain threshold, conduction is there completely facilitated, continuous and distressing (op. cit., 317).

<sup>49</sup> Freud, S., Op. cit., 303. Neurones  $\psi$  are different from neurones  $\phi$  in their function, not in their structure. Group  $\phi$  is part of a developed peripheral nervous system. In the Freudian conception  $\phi$  stands for both, sensation and discharge.

‘would, to put it plainly, be a sympathetic ganglion’.<sup>50</sup> But  $\psi$  evolved further due to the accumulation of  $Q$  from the internal stimuli, but also from receiving small quantities from the outside. It became both, impermeable and permeable. Freud uses *quantity* as the other fundamental parameter in his system to account for the particularities of  $\psi$ .

### C. The problem with quantity

Freud has a problem with quantity from the moment large magnitudes of external  $Q$ s can break the screen barriers in  $\phi$ , overflow  $\psi$ , and cause pain. This disrupts the functioning of the primary psychical apparatus, which is structurally meant to keep off large  $Q$ s through the  $Q$  screens of the sense organs, and has as a function to discharge it. Pain causes a rising of tension in  $Q\eta$ , which will lead to unpleasure in  $\omega$ .

But, for the psychical system to function without succumbing to hallucination, Freud had to invent another group, ‘an agency of reality, a principle of correction’, as Lacan put it in *The Ethics of Psychoanalysis* (Seminar Book VII, 1959-60: 28). It is a true second apparatus, opposed to the first one. As he says in that Seminar, Freud’s  $\phi\psi\omega$  was ‘a system tending towards deception and error . . . That whole organism seems designed not to satisfy need, but to hallucinate satisfaction’.<sup>51</sup> Between hallucinated satisfaction and pain there was only the zone of indifference, equivalent to homeostasis,

---

<sup>50</sup> Ibid. For Lacan Freud’s primitive ego in the  $\psi$  system -and with it ‘the psyche’- is, as Freud put it, a sympathetic ganglion, a ‘buffer-system’ which ‘damps down the system  $\psi$ .’ But it is not consciousness, consciousness has to be placed elsewhere. Lacan also insists that ‘there is no subject ‘represented’ in  $\psi$ ’s quantities or in the *ego*. See Lacan, J., *The Ego in Freud’s Theory and in the Technique of Psychoanalysis* (1954-55), Seminar Book II, op. cit., 116-117.

<sup>51</sup> Lacan, J., *The Ethics of Psychoanalysis*, 25 November 1959, op. cit., 28: ‘The reality principle operates in the mode of detour, precaution, touching up, restraint’.

equilibrium, constancy, inertia. If there was pleasure felt it was only there. The second apparatus, the reality principle was properly introduced by Freud in ‘Formulations of the Two Principles of Psychological Activity’ (1911b), next to the pleasure principle. The equivalent of the two principles were what in the ‘Project’ and the ‘The Interpretation of Dreams’ (1900a), Freud described as primary processes which finally succumb to repression and secondary processes which take up the functioning of the apparatus. For Lacan, these processes involve a ‘moral experience’. They remind us of Aristotle’s *ενεργεια*.<sup>52</sup> If Freud put such an emphasis on quantity, he says, it was not because he was interested in bringing his theory in line with Helmholtz’s and Brücke’s ideas of homeostasis. He expressed an ethical problem and not a mechanistic idea.

‘For him it corresponds rather to the most direct kind of lived experience, namely, that of the inertia which at the level of the symptoms presented him with obstacles . . . It is here that one finds his first advance in darkness toward that *Wirklichkeit* which is the point to which his questioning returns; it is the key, the distinctive feature of his whole system’.<sup>53</sup>

Here the opposition is between inertia and action, (*ενεργεια*), pleasure and reality.

Back in the ‘Project’, system  $\varphi$  was part of the *buffer system*, and had to deal with large amounts of quantity of excitation coming from the outside. In order to bring  $Q$  back to the lowest level, the nerve-endings in  $\varphi$ , that is, the sense organs, acted as *screens*, reducing external stimuli to a minimum and as *sieves*, allowing only certain *periods* of

---

<sup>52</sup> Lacan, J., *Ibid.* Aristotle’s use of the notion of ‘*ενεργεια*’ in the *Nicomachean Ethics* meaning *activity*, *operation* but also *actuality*, *full reality*, is compared by Lacan to Freud’s notion of *Wirklichkeit* used a few times in ‘Formulations’ (1911b).

<sup>53</sup> Lacan, J., *The Ethics of Psychoanalysis*, op. cit., 29. Furthermore: ‘Isn’t the functioning of the apparatus that supports the reality principle strangely similar to what one finds in Aristotle?’ Lacan makes comparisons with Aristotle’s theory of pleasure (*ηδονη*) in the *Nicomachean Ethics* (Book VII, iii.9), which is not a passive state, but an actuality (*ενεργεια*).

excitation to pass from  $\varphi$  to  $\psi$ . This action provided another sort of information, the *quality* of a sensation.<sup>54</sup>

In the ‘Project’'s line of argument, ‘through an increase in the number of neurones and an accumulation of  $Q\eta$ ,  $\psi$  developed further, in order to ‘meet the requirements of the specific action’ due to the ‘urgencies of life’.<sup>55</sup> Neurones  $\psi$  became impermeable, as the quantities received from  $\varphi$  were usually small. These were distributed in the paths (*Bahnungen*) and were calculated according to the formula ‘reminiscent of Fechner’s law.’<sup>56</sup> If it were not for the *Bahnungen*,  $\psi$  would have become totally impermeable, this is Freud’s first point.

It is also important to remember that neurones  $\psi$  receive stimuli from a second source, the internal cells of the body through other neuronal paths. Thus, the second point is that special attention will be required in dealing with the ‘endogenous stimuli’, and ‘endogenous stimuli are of the same magnitude as intercellular stimuli’. Although endogenous stimuli are small and the function of equilibrium in  $\psi$  can thus be preserved –  $\psi$  can continue to be ruled by the pleasure principle<sup>57</sup> – they are freely transmitted without the intervention of particular structures. But, for the same reason, they can

---

<sup>54</sup> But the quality of the sensation will only be felt in  $\omega$ . Freud, S. (1950) [1895], S.E. 1, 306; Freud’s Fig. [12], in the ‘Project’, op. cit., 313.

<sup>55</sup> Op. cit., 303-304. Freud will even discuss a ‘biological argument’ for the evolution of  $\psi$  neurones, a ‘Darwinian line of thought’ of  $\psi$  having developed as being indispensable (ibid). In order to meet the requirements of the specific action, quantities are stored in neurones  $\psi$ . These quantities can be used for the symptoms, as well as for resistance [repression], that is for primary ‘defence’.

<sup>56</sup> Op. cit., 306. The quantities which pass from  $\varphi$  to  $\psi$  are the same as the resistances in the contact-barriers. Cf.: This thesis, Chapter 1, p. 26, note 7, and 51, note 76, about Fechner’s law.

<sup>57</sup> ‘The system  $\psi$  is out of contact with the external world’, it is the system  $\varphi$  which is turned towards the external world, and its locality is what makes it become permeable, not its essence, as Freud indicates (1950a, S.E.1, 304). On the one side  $\psi$  receives stimuli from  $\varphi$ , and on the other side  $\psi$  is in contact with the internal cells of the body’ (ibid.).



become continuous. This can cause a certain amount of distress, as there is no flight from the endogenous stimuli.

#### **D. Quality and the problem of consciousness**

Quantity and Quality are logical categories and here we may be reminded of Freud's attendance of Brentano's lectures on Logic and Aristotle, first his well known attendance of 1874-1875, then another in 1887.<sup>58</sup>

In the construction of his scientific psychology, Freud needs to explain consciousness, hence the use of the second category, that of quality: 'Consciousness gives us what are called qualities – sensations which are *different* in a great multiplicity of ways and whose difference is distinguished according to its relations with the external world.'<sup>59</sup>

He knows that the awareness of consciousness was not included in his quantitative assumptions on the 'neuronal processes'. He is not sure where to place consciousness in his apparatus, but he needs to find them a place in  $\psi$ . 'How and where do qualities originate?' he asks. Usually qualities are associated with perception, therefore they should be placed in the  $\phi$  system, but there are no qualities in the  $\phi$  processes, only quantities, and on the other hand, 'everything argues in favour of the seat of consciousness being in the upper storeys of the nervous system.'<sup>60</sup> It is true that during

---

<sup>58</sup> Lacan, J. (1959-1960), *The Ethics of Psychoanalysis*, Seminar Book II, 192:30.

<sup>59</sup> Freud, S., (1950a [1895]), S. E. **1**, 308.

<sup>60</sup> Freud, S., 1950a [1895], S. E. **1**, 308.

perception the  $\varphi$  and  $\psi$  systems operate together. It is only the reproducing and remembering processes, which are exclusively reserved to  $\psi$  as remembering has nothing of the quality of a perception, normally. The  $\psi$  processes as neuronal processes are without quality, *unbewußt*, unconscious ('unconscioused' suggests Strachey), not known. Therefore we need a third system 'excited along with perception, but not along with reproducing'; it gives rise 'to the different qualities of conscious sensations'.<sup>61</sup>

This is how  $\omega$  system is introduced. It gives us the series of conscious sensations. The further we go into the psychological processes, the smaller are the quantities we come across. It is a progression from the reduced quantities in  $\varphi$  to the further protection from quantities in  $\psi$  and to even smaller quantities in  $\omega$ . Then  $\omega$  only needs to be linked with sound and motor-speech innervations, with articulated utterances, in order to give us consciousness or knowledge of sensations. Freud develops the function of  $\omega$  as attention which the ego uses to direct itself to the choice of sensations, helped by the use of language. He develops the importance of language in the functioning of the psychological apparatus in Part III of the 'Project',<sup>62</sup> but expresses the seminal idea in Part I.  $\Omega$  is invented because he does not only need to resolve the question of 'transference,' of quantities  $Q\eta$  within the unconscious psychological system,  $\psi$ ; he also needs to place the

---

<sup>61</sup> Ibid., 309.

<sup>62</sup> On speech association in the processes of observing, judging and cognizing Freud writes: '. . . speech association . . . consists in the linking of  $\psi$  neurones with neurones which serve sound-presentations and themselves have the closest association with motor speech-images' . . . from there 'to the word-image and from it the excitation reaches discharge', which is an indication of quality and of consciousness. Freud concludes: 'the ego [which] precathects these word-images, as it earlier did with the images of  $\omega$  discharge . . . will have created for itself the mechanism which directs the  $\psi$  cathexis to the memories emerging during the passage of  $Q\eta$ . This is conscious observing thought'. ('Project', Part III, section [1]: 364-365). Freud further underlines that the ego (in  $\psi$  processes) has no way of distinguishing between traces of perceptual processes and traces of thought processes, unless: 'The indications of speech-discharge make good this lack. They . . . lend them [the thought processes] reality and make memory possible, conscious memory (ibid. 366).

indications of quality and/ or reality in the psychical apparatus. They are inextricably linked with language.<sup>63</sup> This is why he adds this third group of neurones, this third system,  $\omega$ . The  $\omega$  neurones share their characteristics with both perception and consciousness.<sup>64</sup> They are placed next to system  $\psi$  and they interest  $\psi$ , as they indicate (inform about) qualities of sensations.<sup>65</sup>  $\Psi$  processes are taking place without the awareness of consciousness, are *unbewußt* (unknown),<sup>66</sup> and this adjective does not

---

<sup>63</sup> The first utterances of the infant, his screams and emotions play a crucial role in the process of ‘internal change’, necessary for the specific action : ‘. . . this path of discharge . . . acquires a secondary function . . . that of *communication*’; thus *extraneous help* can be offered ( ‘Project’ Part I, [11], 318). This is reiterated in Part III, [1], 366: ‘Speech-innervation is originally a path of discharge for  $\psi$ , operating like a safety-valve for regulating oscillations in  $Q\eta$ ; it is a portion of a path to *internal change*, which represents the only discharge, till the *specific action* has been found’. When the external object needs to be ‘understood’ in relation to its predicate (if it is friendly or hostile for example), the representation is dissected in the purpose of cognition and recognition. As Freud will emphasize: ‘Language will later apply the term *judgement* to this dissection and will discover the resemblance . . . between the nucleus of the ego and the constant perceptual component [on the one hand] and between the changing cathexes in the pallium, and the inconstant component [on the other]’ (‘Project’, Part I, 327-328). The whole theory is developed in more details in Part III, *ibid.*, 364-366, and 367: ‘At the start of the function of judgment, when the perceptions on account of their possible link with the wished-for object, are arousing interest . . . when their complexes are dissected into an inassimilable component (*the thing*) and one known to the ego from its own experience (*attribute*, activity) – what we call *understanding*- at this point two links emerge in relation to utterance by speech.’ Freud says that speech utterances are crucial to the first judgment of attribution, for example that there are unpleasant objects out there that make one scream, because they arouse pain. This ‘association of a sound (which arouses motor images of one’s own as well) with a perceptual [image]... emphasizes the object as a hostile one and serves to direct attention to the perceptual image.’ Thus, we can have ‘the first class of conscious memories’ (*Gedächtnisse*). Otherwise memory is unconscious.

<sup>64</sup> Perception is *Wahrnehmung* in German. Freud uses letter *W* as a shorthand for perception, but in the published volume of ‘*Anfänge*’ the editors changed it to ‘*das system W*,’ thinking that Freud was referring to system  $\omega$ , as Strachey notes (Freud, S., (1950), S.E. 1, 363-364). Letter  $\omega$  was probably chosen by Freud, for its likeness to  $w$ , and  $\omega$  neurones do share some qualities with perception. (See the editor’s ‘Introduction to the “Project”’, *op. cit.*, 289). In Part III, it is the ego which directs *attention* to the indications of quality in  $\omega$  and can direct them back to perception. This explains how *attention* works . . . it is these indications of quality which interest  $\psi$  in the perception’ (*Op. cit.*, 360). But if attention fails and  $\psi$  receives quantities from the perceptual neurones  $\varphi$  (noted as *Wqs*), without the help from system  $\omega$ , *perceptions go unnoticed*.  $\Omega$ , on the other hand, receives excitations from perception and provides information to the ego. In that case it could be placed between  $\varphi$  and  $\psi$ .  $\Omega$  cathects perception and contributes to *conscious observing thought*, this cathexis is equivalent to speech associations, the discharge of which furnishes further information to  $\psi$ . Part III emphasizes the link of  $\omega$  which with speech innervations, where lies the distinction between unconscious and preconscious psychical processes (*op. cit.*, 365, and note 1 by Strachey). In Letter 1-1-1896 Freud attributes hallucination to regression back to  $\omega$  only.

<sup>65</sup> ‘During perception, the  $\varphi$  and  $\psi$  systems are both in operation’, but those particular  $\psi$  processes which *are remembering and reproducing* are according to Freud ‘without quality’, without any perceptual quality. We can clearly assume that these are unconscious processes.

<sup>66</sup> ‘We have been treating psychical processes as something that could dispense with this awareness through consciousness . . . neuronal processes . . . are in the first instance to be regarded to their whole extent as unconscious (*unbewußt*)’ (*ibid.* 308).

simply imply their physiological lack of awareness, as Strachey's seems to suggest.<sup>67</sup> These are already fully fledged unconscious psychological processes of desire, and repetition. What is certain, however, is that for the concept of the unconscious to be formulated, Freud needed first to develop the concept of repression. Repression under the name of primary defence exists already in the  $\psi$  processes, but its consequences are not fully understood.

The unconscious processes are thinking-processes which will become *conscious thought* with the help of speech associations in the 'Project', Parts I and III.

Freud uses the invention of  $\omega$  neurones, in order to insert consciousness in the psychical apparatus, while on the other hand, like Hughlings Jackson, he considers consciousness as a dispensable appendage. He oscillates between this and the more established view of 'consciousness as the subjective side of all psychical events and thus inseparable from the physiological mental processes'. He chooses, as he says, the middle road:

'Consciousness is the subjective side of one part of the physical processes in the nervous system, namely of the  $\omega$  processes; and the omission of consciousness does not leave psychical events unaltered but involves the omission of the contribution from  $\omega$ '.<sup>68</sup>

He does not forget the problem of quantity in neurones  $\omega$ . But quantity is not compatible with consciousness. So  $\omega$  receive quantities smaller than  $\psi$ . Small

---

<sup>67</sup> Strachey is keen to distinguish the participle *unbewußt* from the later *das Unbewußte*, the Unconscious proper. (Freud, S. 1950a, S.E. 1, 308, note 2).

<sup>68</sup> Freud, S., 1950a [1895], 311. In his Seminar *The Ego in Freud's Theory and in the Technique of Psychoanalysis* (Seminar Book II, 1954-1955), Lacan proposed  $\omega$  neurones as 'a prefiguration of the *id*' (2 Feb. 1955, op. cit., 99).

quantities mean that  $\omega$  neurones should be impermeable like  $\psi$ , but this would not be compatible for the neurones which are responsible for consciousness. He associates  $\omega$  neurones with mutability, transitoriness and simultaneity. <sup>69</sup> ‘Neurones  $\omega$  behave like organs of perception and in them we could find no memory’.<sup>70</sup>

Still there is discharge equivalent to the information they provide, that of quality. In order to resolve the problem of discharge in neurones which do not receive any significant amount of  $Q\eta$ , Freud declares that  $\omega$  neurones ‘are incapable of receiving  $Q\eta$ ’ and only ‘appropriate the *period* of the excitation . . . and that this state . . . is the fundamental basis of consciousness’. Of course, the  $\psi$  neurones have their *period* too, but it is without quality, ‘monotonous’, as Freud says. <sup>71</sup> When there is an increase in cathexis (tension in  $\psi$ ) it is felt as unpleasure in  $\omega$ , and the lowering of tension in  $\psi$  is felt as pleasure in  $\omega$ . Consciousness is the quality of a sensation as a difference and a difference felt as either pleasure or unpleasure, but primarily as unpleasure.<sup>72</sup>

---

<sup>69</sup>  $\Omega$  neurones share some characteristics with the perceptual neurones, such as permeability and transitoriness; we could assume that, if they are placed between  $\phi$  and  $\psi$ , and not after  $\psi$ , they or at least their psychical effects could be a precursor of  $Wz$ , the *Wahrnehmungszeichen* we find in ‘Letter 52’ to Fliess (Masson J.M., op. cit., 20). Freud gives them a psychical significance, only if they become conscious.

<sup>70</sup> This group  $\omega$  will be made only of qualities, qualities of sensations, conscious sensations, as Freud states when he introduces them in Part I of the ‘Project’ (op. cit., 309). However, Freud faces certain difficulties in placing consciousness in his psychical system. In his Letter of 1st January 1896, in the summary of the  $\phi\psi\omega$  he sends to Fliess, he writes: ‘I now [in my new scheme] insert these  $\omega$  neurones between the  $\phi$  neurones and the  $\psi$  neurones, so that  $\phi$  transfers its quality to  $\omega$  and  $\omega$  now transfers neither quality nor quantity to  $\psi$ , but mere excitation’. (Masson, J. M., op. cit., 160). Here he clearly states that ‘the perceptual processes would involve consciousness’ while ‘the  $\psi$  processes would be unconscious’ and would acquire later ‘a secondary artificial consciousness’ through ‘processes of discharge and perception’ (speech association) . . . ‘Any  $\omega$  discharge . . . now becomes unnecessary, and hallucination . . . is now no longer a backward movement to  $\phi$  but only to  $\omega$ ’ (ibid).

<sup>71</sup> Freud, S. 1950a [1895], 310.

<sup>72</sup> It seems that the first class of conscious memories are the ones that arouse unpleasure (ibid. p. 367).

### E. The apparatus $\varphi\psi\omega$ and its functioning

The functioning of  $\varphi\psi\omega$  accounted for primary, complete, discharge with room for a secondary function of keeping  $Q\eta$  as low as possible through indications of quality, reality and other structural devices. In the  $\psi$  system special contrivances for delay and resistance are being constructed. They are represented by a special group of neurones which Freud will call 'ego' (*Ich*). It is in charge of primary defence.<sup>73</sup>

As a matter of fact only medium quantities operate in the  $\varphi$  neurones, the nerve-endings of which, the sense organs, act as screens, and sieves against excess quantities.<sup>74</sup> Those reduced  $Q\eta$ s are then transferred from  $\varphi$  to  $\psi$ . On the other hand  $\varphi$  communicates directly with the motor end of the apparatus where there is discharge or release of the excitation.

'The quality characteristic of the stimuli proceeds through  $\varphi$  by way of  $\psi$  to  $\omega$ , where it generates sensation. It is represented by a particular period of neuronal motion which is certainly not the same as that of the stimulus, but has a certain relation to it in accordance with a reduction formula which is unknown to us' (Freud, S. 1950a[1895], 314).

Freud develops the reduction formula which he relates to Fechner's law. He also introduces a new schema for it:

<sup>73</sup> In his article '*Remarques sur das Ding dans l'Esquisse*' (*Littoral* no 6, October 1982, Paris, érès) J.P. Dreyfuss suggests that Freud's ambition in the 'Project' was to build something like a machine or like 'the blueprint of a true scientific theory, so that all experience already acquired or to come, would find its place in it'. He proposes two schemata of the 'Project's 'experience of satisfaction', and a topology for *the thing*, an eulerian topology: '*The thing* can rather be equalled to the empty intersection of two disjoint sets, such as it can be figured on a piece of paper with two dimensions' (op. cit., 58). Therefore a third dimension is introduced in Freud's construction.

<sup>74</sup> Not all stimuli reach the various end-points, 'they have a quantity and a qualitative characteristic', concerning quantity they are 'firstly *reduced* and secondary *limited*', concerning quality they have a *period* and so they are discontinuous (See Freud, S. 1950a [1895], 313). The sensation generated in the  $\omega$  neurones does not leave any trace of memory behind it (Ibid., 314).

‘The reduction of stimuli’

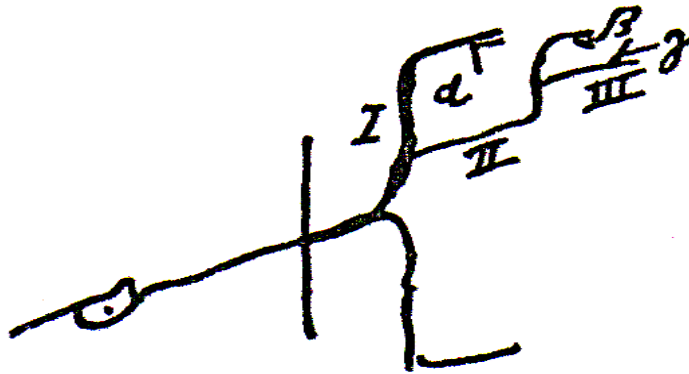

[Fig. 13], Freud S., (1950a [1895]), S. E. **1**, 313

The free flow of medium quantities is transferred through neurones  $\varphi$  and then only a quotient of them to  $\psi$ . There they meet other special contrivances destined again to keep off  $Q\eta$  from  $\psi$ . Thus a stronger stimulus, which could have a stronger psychical effect, follows different pathways than a weaker one. ‘The sensory path of conduction in  $\varphi$  is constructed in a peculiar fashion. It ramifies and exhibits thicker and thinner paths . . .’<sup>75</sup> Thus,  $1(Q\eta)$  in  $\psi$  will travel through path I to terminal  $\alpha$ ,  $2(Q\eta)$  will pass along path II, which is narrower, and will open up another terminal in  $\beta$ , while  $3(Q\eta)$  will open the narrowest path III towards another terminal  $\gamma$ . Thus Freud demonstrates that quantity in  $\varphi$  is replaced by *complication* in  $\psi$ .<sup>76</sup>

<sup>75</sup> Ibid.

<sup>76</sup> Freud reminds us of Fechner’s law which formulates the relation between changes in the intensity of a stimulus and changes in the resultant sensation. It has a reduction formula which Freud uses: ‘sensation varies with the logarithm of the strength of the stimulus.’ Freud thinks he can locate Fechner’s law in the  $\psi$  neurones. There  $Q\eta$  reduction is achieved through transformation of quantity into *complication* by the opening of new paths in terminals  $\alpha$ ,  $\beta$ ,  $\gamma$ , in  $\psi$ : Thus the passage of  $3(Q\eta)$  is reduced in  $\psi_1 + \psi_2 + \psi_3$ . And Freud will ask if a  $3(Q\eta)$  passing once is the same as  $1Q\eta$  passing three times,  $Q\eta_1 + Q\eta_2 + Q\eta_3$ . What happens here is a qualitative change, as Freud points out. Quantity, or at least most of it, changes to complication and

The nucleus of  $\psi$  also receives excitations from the internal organs; as Freud underlines, it is exposed there to quantities of stimuli without any protection, which meant that from very early on the law of inertia or of constancy was broken, and a ‘specific action’ was required to appease excitation. This could only be performed with the help of an experienced outsider.<sup>77</sup>

Freud situates ‘the mainspring of the psychological mechanism’ in the endogenous stimuli (*endogene Reize*),<sup>78</sup> which are of an ‘intercellular nature’, arise continuously, and only periodically become psychological stimuli (*psychische Reize*).<sup>79</sup> An accumulation of  $Q\eta$  takes place in the nucleus of  $\psi$  where the resistances are rather low. Freud called this process ‘summation’. It results in a rise in tension felt in  $\psi$ .<sup>80</sup>

## F. The experience of ‘satisfaction’

Freud explained that when neurones  $\psi$  in the nucleus are filled with  $Q\eta$  from the internal

---

is expressed topographically.’

<sup>77</sup> Freud, S., (1950a [1895]), 297.

<sup>78</sup> Op. cit., 316; *Aus den Anfängen der Psychoanalyse*, op. cit., 401: *Hierin liegt die Triebfeder des psychischen Mechanismus. Feder* means here ‘spring’, *Triebfeder* is the ‘spring of the drive’. ‘Here lies the drive, the mainspring of the psychological mechanism’ (my translation).

<sup>79</sup> The endogenous stimuli are therefore a precursor of the drives, as Strachey notes, ‘the impulsion - in the interior of the system - which sustains all psychological activity . . . the will, the derivative of the drives’ (Ibid, 316-317). Freud places the drive on the border between the somatic and the psychological.

<sup>80</sup> The  $\psi$  contact-barriers in the pallium are generally higher than the barriers in the [endogenous] paths of conduction in the nucleus: ‘so that a fresh accumulation of  $Q\eta$  can occur in the nuclear neurones’ (Ibid., 317). In the pallium, after the passage of excitation,  $\psi$  neurones return to a state of relative impermeability, of constant resistance maintained. On the other hand, in the nucleus,  $\psi$  neurones are without protection: ‘ $\psi$  is here at the mercy of  $Q$ , and it is thus that in the interior of the system there arises the *impulsion* which sustains all psychological activity . . . We know this power as the *will*, the derivative of the *drives*; ‘Aus den Anfängen der Psychoanalyse’, 401-2: ‘ $\psi$  ist hier der *Quantität(Q)* preisgegeben und damit entsteht im Innern des Systems der *Antrieb*, welcher alle psychische Tätigkeit unterhält. Wir kennen diese Macht als den Willen, den *Abkömmling der Triebe*.’ *Antrieb* is the impulse, the impetus, the motivation.



stimuli, the created state of urgency<sup>81</sup> heads for discharge, because of the generated unpleasure felt in  $\omega$ . Internal change (*innere Veränderung*) is needed first, a motor - discharge, namely the child's emotional response, screaming and gesticulating, This is not sufficient, however, as full discharge can only be obtained through 'extraneous help' (*fremde Hilfe*), for the *specific action* to take place.<sup>82</sup> The outsider is an experienced and resourceful individual (*ein erfahrenes, ein hilfreiches Individuum*). For the appeal to find a response, a secondary function is needed, the function of communication, which will result from the baby's cry. The whole experience amounts to what Freud calls 'the experience of satisfaction':

'When the helpful person has performed the work of the specific action in the external world on behalf of the helpless one, the latter is in a position, by means of reflex contrivances, immediately to carry out, in the interior of the body, the activity necessary for removing the endogenous stimulus. The total event then constitutes an experience of satisfaction.'<sup>83</sup>

The experience of satisfaction produces radical results for the subject, a development of  $\psi$ , as Freud says. Discharge takes place in the nuclear neurones and two kinds of cathexes in the pallium happen simultaneously. The results are: 1) a *mnemic* image of the object which contributed to the experience of satisfaction and 2) a *mnemic* image of the reflex movement (a motor image) performed by the subject following the specific action; 3) a link is established between the two *mnemic* images in the pallium and the nuclear neurones from

---

<sup>81</sup> 'Now when the state of *urgency* or *wishing* re-appears . . .' (Freud, S., 1950a [1895]), 319). 'Urgency' is Strachey's translation for *Drang* (G.W., 402), the constant push of the drive. The drives are the indomitable force, the 'necessity of life' (*Das Not des Lebens*). '*Begierde in dem Ich*', 'desire in the ego', is translated by Strachey as 'craving'. In *The Ethics of Psychoanalysis*, Lacan called it: 'the appetitive process' (Seminar Book VII, Session 25 November 1959). It is the state produced when the memory of the experience of satisfaction is re-activated.

<sup>82</sup> '*Die spezifische Action*', in Freud, S., G.W., 402. There are earlier and later occurrences of the term such as in Freud's papers on 'Anxiety Neurosis' (1895b), and 'Repression' (1915d), as well as in 'Civilization and its discontents' (1930a). The appeal to another person springs from 'the initial helplessness of human beings' and becomes 'the primal source of all moral motives' (Freud, op. cit., 297).

<sup>83</sup> '*Die Befriedigungserlebnis*', Freud, S., G.W., 402-4; Freud, (1950a [1895]), 317, 318, n. 2 and 319.

which information arrives both of tension and discharge. The  $\psi$  neurones, which were previously cut off from one another by contact-barriers with strong resistances, will now be linked via a ‘basic law of association by simultaneity’ which operates during pure  $\psi$  activity of reproductive remembering:

‘We find that consciousness - that is the quantitative cathexis of a  $\psi$  neurone  $\alpha$ , passes over to another,  $\beta$ , if  $\alpha$  and  $\beta$  have at some time been simultaneously cathected from  $\varphi$  (or from elsewhere). Thus a contact-barrier has been facilitated through the simultaneous cathexis  $\alpha$ - $\beta$ . It follows . . . that a  $Q\eta$  passes more easily from a neurone to a cathected neurone than to an uncathected one. Therefore the cathexis of the second neurone operates like the increased cathexis of the first one. Once again cathexis is here shown to be equivalent, as regards the passage of  $Q\eta$ , to facilitation.’<sup>84</sup>

There is a second factor for the direction of  $Q\eta$  in a neurone  $a$ : the cathexis ( $Q\eta$ ) will not only take the path of the best facilitated barrier, but also the path to ‘the barrier which is cathected from the further side. The two factors may support each other or may in some cases operate against each other’. Freud gives a representation of this process of side-cathexes. This activity now takes place within the newly formed organization he calls *Ich*, ‘ego.’ The ego’s function is inhibition or side-cathexis formalized in the schema below:<sup>85</sup>

---

<sup>84</sup> Curiously consciousness here is the equivalent of quantity in  $\psi$  (Freud, S., (1950a [1895], 319). As Freud had said earlier (ibid, 300-301), the strength of an excitation, and the frequency it passes over can replace simple  $Q\eta$ . Lacan noted Freud’s difficulty to place consciousness within the psychical apparatus. In Part I of the ‘Project’, section [21] on *Dream Consciousness* (ibid., 341), consciousness seems to affect all systems under the condition that the current of  $Q\eta$  should be neither monotonous nor intense: ‘. . . it is to the outcome of the movement that it [consciousness] attaches to, a comparatively quiet lingering, as it were, of the cathexis’ (Ibid., 342-343). Freud seems to be uncertain as to what the preconditions of consciousness are.

<sup>85</sup> Freud, S., (1950a [1895]), 324: ‘If we suppose that a  $Q\eta$  enters a neurone  $a$  from outside ( $\varphi$ ), then, if it were uninfluenced, it would pass to neurone  $b$ ; but it is so much influenced by the side-cathexis  $a - \alpha$ , that it gives off only a quotient to  $b$  and may even perhaps not reach  $b$  at all. Therefore, if an ego exists, it must inhibit psychical primary processes’. Freud will make the ego take up the original  $Q\eta$  release of unpleasure and use it as inhibition in the side-cathexis.

‘The side cathexis; inhibition’

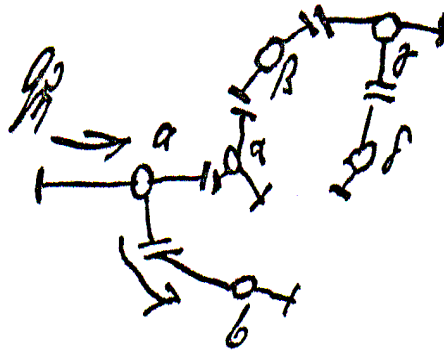
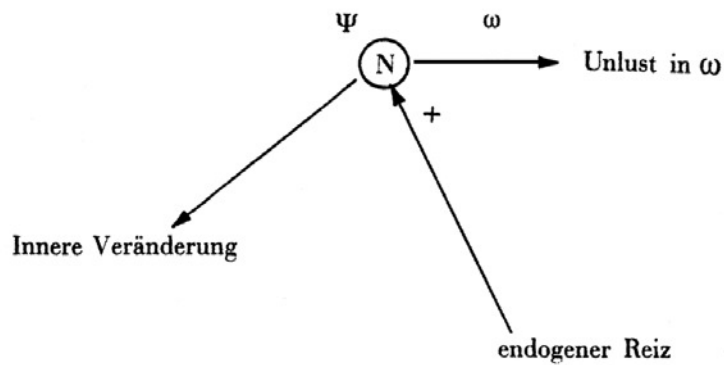

Figure [14], Freud, S., 1950[1895], S. E. **1**, 324.

In his paper ‘*Remarques sur das Ding dans l’Esquisse*’ (1982), Jean Pierre Dreyfuss developed a number of interesting points on the experience of satisfaction as described by Freud in the ‘Project’.<sup>86</sup> He proposed a series of diagrams.

<sup>86</sup> Dreyfuss J. P (1982), op. cit. Dreyfuss finds Lacan’s ‘big Other’ in the ‘experienced outsider’, and therefore assumes the introduction of the symbolic order with the appeal made to the Other. Freud had qualified the human helplessness (*Hilflosigkeit*) as ‘the mainspring of all moral motives’ (*die Urquelle aller moralischen Motive*). Dreyfuss notes the topology of *das Ding* as an eulerian intersection (cf. Note 71 above). Freud designated the inassimilable component of the experience of satisfaction with letter *a*, and called it *das Ding* (Freud, S., 1950a [1895]), 328). In the structure of *das Ding* Dreyfuss finds equally something which is ‘radically Other’. As he says: It is with the experience of the fellow human being (Freud’s *Nebenmensch*), that the subject finds its first satisfying or hostile object, partly cognizable, and partly ‘new and non-comparable’. Lacan talks about it in the following terms: ‘*das Ding* as *Fremde*, strange and even hostile . . . an outside . . . the subject’s absolute Other . . . the one he is supposed to find again . . . through hallucination.’ (See Lacan’s *The Ethics of Psychoanalysis*, Seminar Book VII (1959-60), 52. Freud, on the other hand, underlined ‘the resemblance between the nucleus of the ego and the constant perceptual component [*a*]’ (Freud, S., 1950a [1895], 328).

## Dreyfuss 1: 'The 'state of urgency'



Dreyfuss, J.P., *Littoral* no 6, 1982, 48

The internal excitation (*endogener Reiz*) reaches the nucleus of  $\psi$  (N), plus (+) unpleasure (*Unlust*) is produced in  $\omega$  and leads to 'internal change' (*Innere Veränderung*).

## Dreyfuss 2: 'The 'specific action' and the 'experience of satisfaction'

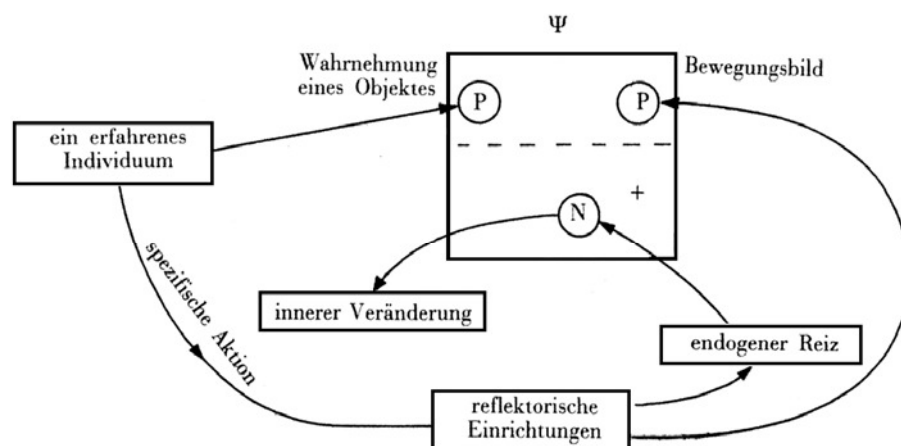

It shows the circuit from the perception (*Wahrnehmung*) of an object in P (*Pallium*) to the formation of a movement (*Bewegungsbildung*) for obtaining satisfaction via the specific action (*spezifische Aktion*) and the internal change.

Dreyfuss, J.P., *Littoral* no 6, 1982, 49

Dreyfuss 3, 'The state of desire'

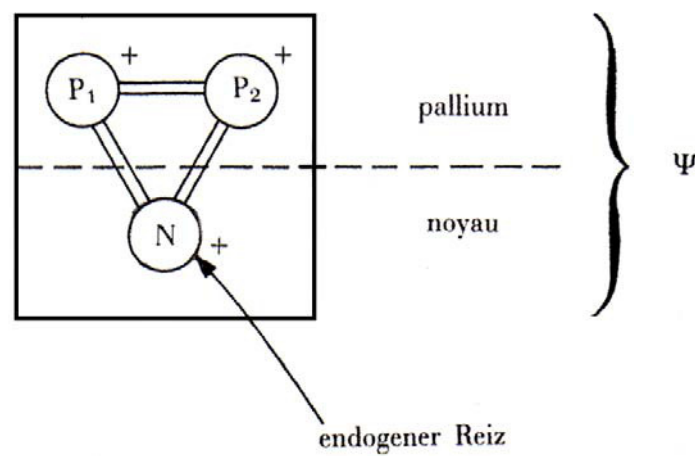

Dreyfuss, J.P., *Littoral* no 6, 1982, 50

And below we show in comparison the diagram of the limits of body and psyche as drawn by Freud in *Draft G - Melancholia* (undated, belongs to an envelope of Letter to Fliess, January 7, 1895).

The 'Schematic Picture of Sexuality' (Cf.: This Thesis, Chapter 2, p. 81):

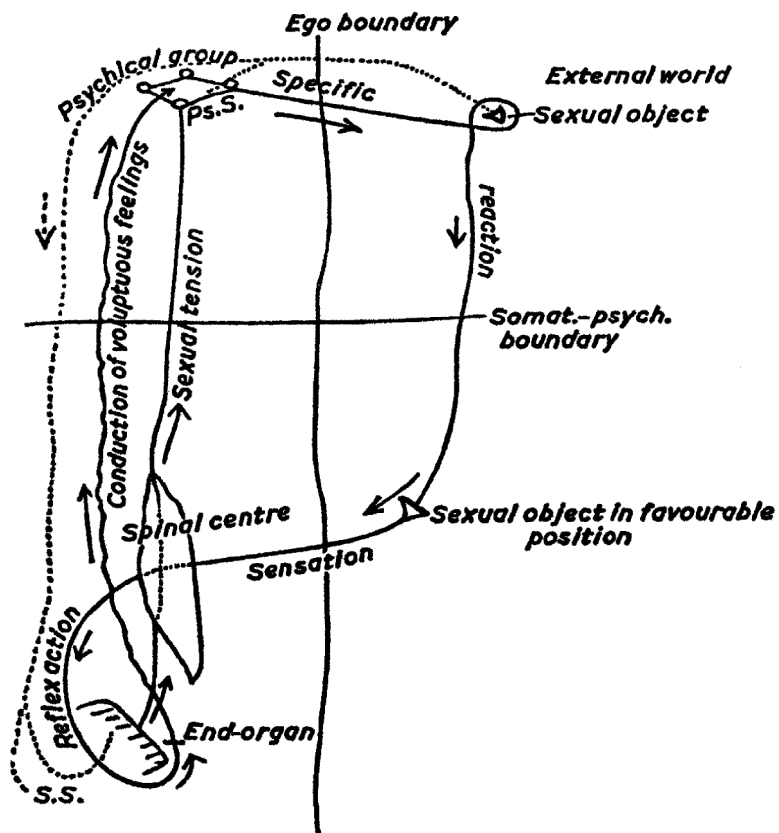

Masson J.M., op. cit., 1985, 100

As Freud wrote in the 'Project' (1950a [1895]), the original experience of satisfaction can be repeated as a state of desire (*Wunschzustand*), in which cathexis flows onto two *mnemic* images on the pallium ( $P_1$  and  $P_2$  in the schema 'Dreyfuss 3'). The result will be the 'hallucination' of the object which granted satisfaction in the first place, followed by

discharge (*hallucinatory satisfaction*) in the nucleus (N, in the schema). If this cannot be prevented, ‘disappointment cannot fail to occur’: ‘I do not doubt that in the first instance this wishful activation will produce the same thing as a perception – namely a hallucination. If reflex action is thereupon introduced, disappointment cannot fail to occur’.<sup>87</sup>

Hallucination can be produced during the state of desire when the activated memory traces go unhindered by the ego. It causes an effect of perception.

When, in his Seminar *The Ethics of Psychoanalysis* (1959-1960), Seminar Book VII (1992), Lacan described Freud’s division of the psychical experience between the pleasure principle and the reality principle as a moral and ethical division, he drew a diagram which showed how this division runs between, on the one side, ‘perception . . . linked to the activity of hallucinating, to the pleasure principle’ and, on the other side, thought. Thus what Freud calls psychical reality has two sides, a fictional process, a process of inertia, ruled by the pleasure principle, and on the other side, thought processes, the appetitive process, ‘a process of search, of recognition and . . . of recovery of the object’. Lacan’s diagram is not two or rather three parallel lines, it is a set of *criss-cross* lines making us think of an intersection, that is, we can already think topologically:

‘The reality principle controls what happens at the level of thought but it is only insofar as something emerges from thought which can be articulated in words . . . come to the knowledge of the subject in his consciousness. Conversely, the unconscious itself is to be situated at the level of elements, of logical components which are of the order of *λογος* articulated in the form of *ορθος λογος* . . .’

---

<sup>87</sup> Freud, S., (1950a [1895]), S.E. **1**, 319.

For Lacan, three orders emerge in the early works of Freud: first ‘a substance or a subject of psychic experience which corresponds to the opposition reality principle/pleasure principle’; second ‘a process of experience which corresponds to the opposition between thought and perception . . . divided according to whether it is a question of perception . . . linked to the activity of hallucinating, to the pleasure principle, or to a question of thought.’ This is what Freud calls *psychical reality*:

‘On one side there is the fictional process, on the other the processes of thought . . . and the appetitive process, a process of search of recognition and . . . of recovery of the object . . . Finally. . . on the level of the object, the known and the unknown are in opposition.’<sup>88</sup>

There is a structure in all that. But, as Lacan underlines, Freud leaves us with the question of what would be ‘good’ or ‘happiness’ which would not be in the realm of the ‘pleasure principle’.

‘The criss-cross of the psychical functions’



<sup>88</sup> Lacan, J., (1959-1960), op. cit., 33.



Lacan, J., (1959-1960), Seminar Book VII, *The Ethics of Psychoanalysis* (1992), 34.

### G. Pain and Affects

With the experience of satisfaction, Freud brings in the experience of pain:

‘Normally,  $\psi$  is exposed to  $Qs$  from the endogenous paths of conduction, and abnormally, even though not yet pathologically, in cases where excessively large  $Qs$  break through the screening contrivances in  $\varphi$  – that is in the case of pain... Pain gives rise in  $\psi$  (1) to a large rise in level, which is felt as unpleasure by  $\omega...$ , (2) to an inclination to discharge...and, (3) to a facilitation between the latter[the inclination to discharge] and a *mnemic* image of the object which excites the pain’.<sup>89</sup>

Pain arises from excessive quantities of excitation both from the external world but also from the interior of the body. Pain has a ‘peculiar *quality*’ which is felt along with unpleasure, as Freud notes. However, during the process of remembering and reproducing, what is felt is not exactly pain but *affect*, which ‘has a resemblance to it’. It includes unpleasure together with the inclination to discharge.

‘In the actual experience of pain it was the irrupting external  $Q$  that raised the  $\psi$  level. In the reproduction of the experience -in the *affect*- the only additional  $Q$  is that which cathects the memory. . . It only remains to assume . . . that owing to the cathexis of memories unpleasure is released from the interior of the body . . .’<sup>90</sup>

Unpleasure is provided in the interior of the body by other neurones which Freud calls ‘secretory’ (*sekretorischen*) or ‘key neurones.’<sup>91</sup> They influence the production of  $Q\eta$  and

<sup>89</sup> Freud, S., (1950a [1895]), 320. Freud defined pain as follows ‘pain consists in the eruption of large  $Qs$  into  $\psi...$  Pain sets the  $\varphi$  as well as the system  $\psi$  in motion, there is no obstacle to its conduction, it is the most imperative of all processes.’ (Op. cit., 307)

<sup>90</sup> Op. cit., 320.

<sup>91</sup> Ibid., note 4. In his notes Strachey argues that although the manuscript has ‘motor’ (*motorischen*) neurons, it seems likely that this was a slip for ‘secretory’ (*sekretorischen*). On the contrary, Lacan argues that this is ‘Not a mistake... Here lies the gap between *Wunsch* and *Befriedigung*. He [Freud] draws the attention . . . to

‘operate as a stimulus in the endogenous paths of conduction to  $\psi$ ’ and they also communicate with motor neurones for discharge. They do not discharge  $Q\eta$  but, as Freud points out, ‘they supply it in roundabout ways’. Then, when a certain level has been reached in  $\psi$ , they are excited. ‘As a result of the experience of pain’ the mnemonic image of the hostile object has acquired an excellent facilitation to these key neurones, in virtue of which [facilitation] ‘unpleasure is now released in the affect’.<sup>92</sup>

In the ‘Project’ Freud seems to reserve the term ‘affect’ for the experience of pain. Pain is transformed into affect (un-pleasure in  $\omega$ ) while the leftovers after the experience of satisfaction (pleasure) are ‘wishful states’, states of desire, as it would be more accurate to say. They both involve a rising of  $Q\eta$  tension in  $\psi$  and, in the case of sexual release, although this is not properly a process of release, but of excitation, something similar happens, there is a feeling of un-pleasure, and this is what happens in the neuroses. Both experiences involve a rise of  $Q\eta$ , either by *summation* (in the wishful state) or by sudden *release* (in the affect), therefore the repetition of the experience, the affect of pain due to the hostile object’s repetitive cathexis, leads to the latter’s abandonment. A biological lesson has been learned, as Freud notes. He called this psychological process *primary defence* or *repression*.<sup>93</sup>

---

the analogy that exists between that search for an archaic . . . almost regressive quality of *indefinite pleasure* which animates unconscious instinct as a whole . . . and that which is *realized and satisfying* in the fullest of senses . . .’ (Lacan, J., Seminar Book VII, *The Ethics of Psychoanalysis*, 41-2). The strange thing, he adds, is that it all seems to happen in the same place. Pleasure and unpleasure, satisfaction and pain, and the longing for the Thing, all happen in the same place.

<sup>92</sup> Op. cit., 321

<sup>93</sup> Op. cit., 322. In *Beyond the Pleasure Principle* (1920g) Freud returns to the theory of pain. Pain ‘gives rise to feelings in the pleasure-unpleasure series’, internal excitations produce unpleasure and ‘set in motion every possible defence measure’, such as projection, for example, while external excitations which break through the protective shield are considered traumatic (Freud, S., 1920g, S.E. 18, 29). In *Inhibitions, Symptoms and Anxiety*, Freud dealt with a new aspect of pain, psychical pain which is caused by the loss of an object of love, the mother for instance (Freud, S., 1926d, S.E. 20, 170-172).

## H. The ‘ego’ and inhibition

The two previously described processes, the wishful attraction to ‘the mnemic image of the wished-for object’<sup>94</sup> and the inclination to repression of the hostile mnemic image, both indicate that: ‘. . . an organization has been formed in  $\psi$  whose presence interferes with passages [of quantity] which on the first occasion occurred in a particular way [i.e. accompanied by satisfaction or pain].’<sup>95</sup> Freud calls this organization ‘ego’ (*Ich*). It is ‘a group of neurones constantly cathected in  $\psi$  . . . It is also ‘the totality of  $\psi$  cathexes, at the given time, in which a permanent component is distinguished from a changing one.’

Produced by the repeated reception of endogenous  $Q\eta$  from certain neurones (of the *nucleus*), and their connections, the ego becomes the ‘*vehicle of the store* required by the secondary function’ (flight from the stimulus).

‘While it must be the endeavour of the ego to give off its cathexes by the method of satisfaction, this cannot happen in any other way than by its influencing the repetition of experiences of pain and of affects, and by the following method, which is described generally as inhibition.’<sup>96</sup>

Here there is a sort of confusion between inhibition and repression. Freud asserts that, ‘if an ego exists, it must inhibit primary psychological processes.’<sup>97</sup> The ego is, for Freud, a structure, *Aufbau*. It achieves inhibition through the many side-cathexes. Thus, in [Fig. 14] of the ‘Project’ we note that if neurone ‘a’ (the hostile mnemic image) -which is in  $\psi$ - receives a

<sup>94</sup> Freud, S., (1950a [1895]), S. E., **1**, 322.

<sup>95</sup> Op. Cit., 323.

<sup>96</sup> Ibid.,

<sup>97</sup> Op. Cit., 324.

large  $Q\eta$  from  $\varphi$ , the side connexion a- $\alpha$  will inhibit the process and  $Q\eta$  will probably never reach  $b$  (the key neurone releasing unpleasure).

The 'ego' is thus constructed as an agent of defence, in order to take the excitation away from the trajectory of 'discharge' which would cause unpleasure. Freud says that this structure (*Aufbau*) takes all the quantity of unpleasure in its charge, and uses it for the side-cathexis (the defence mechanism): '. . . in that case, the stronger the unpleasure, the stronger will be the primary defence'.<sup>98</sup> To achieve this aim the ego's uses the mechanism of attention.

### **I. A subject or an ego?**

As Freud suggests, subjected to the repetition of the experiences of satisfaction and pain, the ego is vulnerable and can be damaged: 'while in the wishful state, it newly cathects the memory of an object and then sets discharge in action; in that case satisfaction must fail to occur, because the object is not *real* but is present only as an imaginary *idea*.'<sup>99</sup>

The ego needs to use a certain criterion to distinguish between real and imaginary object, and an indication to say if the object is friendly or hostile. In the first case attention is used, in the second case, *inhibition*. If the mechanism fails, massive unpleasure is threatened and massive defence will be used.<sup>100</sup> The 'Project' 's ego (*Ich*) seems to take upon itself a certain amount of unpleasure and share some characteristics of the object itself, namely a

---

<sup>98</sup> Ibid.

<sup>99</sup> Ibid., 325.

<sup>100</sup> Ibid.

permanency, tinted with unpleasure. And this is how it achieves inhibition.

The richness and extension of the Freudian '*Ich*' is not covered by a translation such as 'ego' (*moi*).<sup>101</sup> In a recent French edition of the 'Critique of Pure Reason' Kant's concept of pure reason *Ich* was translated as *Je* (I). Freud's *Ich* or *das Ich* is certainly not the concept of pure reason, but it would have also gained, had it been translated as 'I'.<sup>102</sup>

In *The Ego in Freud's Theory and in the Technique of Psychoanalysis* (1954-1955), Seminar Book II (1988), Lacan approached this question by arguing that 'the unconscious is the unknown subject of the ego, that it is 'misrecognized by the ego,' that the primary processes 'have an ontological meaning' in Freud 'when he is discussing them as the core of our being' (*Kern unseres Wesens*), as he did in 'The Interpretation of Dreams' (1900a).<sup>103</sup> As Lacan asks:

'What do we know about the ego? Is the ego real, is it a moon or is it an imaginary construction? We start with the idea . . . that there is no way of grasping anything whatsoever of the analytic dialectic if we do not assume that the ego is an imaginary construction . . .'<sup>104</sup>

In his development he first presents the 'ego' within the analytic dialectic of intersubjectivity. But, beyond intersubjectivity which is imaginary, beyond the

<sup>101</sup> The drafting of a divided *Ich* appeared in Freud's posthumously published short text: 'The Splitting of the Ego in the Process of Defence' (*Die Ichspaltung im Abwehrvorgang*), (Freud, S. (1940e) [1938], S.E. 23, 204).

<sup>102</sup> Dorgeuille, C., 'The question of the subject', debate Conté, C., 'From the subject to topology', *Etudes Freudiennes*, no 33, Paris, 1992. In his topological essays, Jean Michel Vappereau proposed the idea of the subject as 'stuff' (*étouffe*) (Vappereau, J.M., 'Etoffe, Surfaces Topologiques Intrinsèques', in *Topologie en Extension*, Fascicule no 2, Paris 1988, 42).

<sup>103</sup> Lacan, J., 1954-1955, *The Ego in Freud's Theory and in the Technique of Psychoanalysis*, session 8 December 1954, Seminar Book II(1988), 41.

<sup>104</sup> Lacan, J., Op. cit., 25 May 1955, 243.

‘interpsychological experience’, is ‘the path of language’. The ego is an imaginary construction, ‘it is the other, the fellow being, the imaginary object, but all within an organized system, which is the wall of language’, as he calls it. He then uses a schema to show the four coordinates of the psyche, *S* the subject, *A*, the Other of language, *a* the ego and its objects and *a'* the specular other. This is his schema, Schema *L* for *Lacan*.

Schema *L*

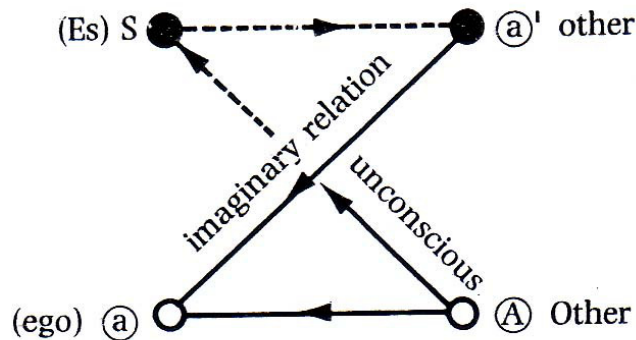

Lacan, J., (1954-1955), Seminar Book II 25 May 1955, op. cit., 243)

‘*S* is the letter *S*, but it’s also the subject, the analytic subject, that is to say not the subject in its totality . . . but in its opening up. As usual, he does not know what he is saying. If he knew . . . he wouldn’t be there. He is there down on the right.’<sup>105</sup>

<sup>105</sup> Ibid. Cf.: this thesis, Chapter 3, p. 155, note 65.

## J. ‘Letter 52’ to Fliess

Between the ‘Project’ (1895) and ‘The Interpretation of Dreams’ (1900a) comes a short text which is a significant step in the development of Freud’s first theory of the psychological apparatus. It is his letter to Fliess of December 6, 1896, known as ‘Letter 52, Extracts from the Fliess Papers’ in the Standard Edition, Vol. 1. <sup>106</sup> The whole of that year Freud continued working on the theory of the neuroses, their cause and how the choice of neurosis was effectuated. Just after finishing his *ψω*, he dispatched a revised summary of it to Fliess, in his letter of January 1, 1896, and with it enclosed ‘Draft K’ known as ‘*The Neuroses of Defence (A Christmas Fairy Tale)*’, a preliminary sketch of his second paper on the ‘*Neuro-Psychoses of Defence*’ (1896b). ‘Letter 52’, which concludes the year, is, for Freud, ‘a bit of a speculation’. Its importance lies in:

‘. . . the assumption that our psychic mechanism has come into being by a process of stratification: the material present in the form of memory traces being subjected from time to time to a re-arrangement [*Umordnung*] in accordance with fresh circumstances, to a retranscription [*Umschrift*].’<sup>107</sup>

As Freud underlines, ‘memory is present not once but several times over . . . it is laid down in various kinds of indications’ (*Niederschrifte*). <sup>108</sup> There are ‘at least three or more’ of those registrations, separated, as in his schema below, but, he insists, not necessarily ‘topographically’. He uses new shorthand signs, *Wz*, [*Wahrnehmungszeichen*], *Ub*, [*Unbewußtsein*], *Vb*, [*Vorbewußtsein*], to indicate these transcriptions or registrations.

<sup>106</sup> Freud, S. (1950a [1892-1899]), op. cit., p. 233-239; Masson, J.M., *The Complete Letters of Sigmund Freud to Wilhelm Fliess* (1985), p. 207-215. Harvard University Press, Cambridge Massachusetts, and London.

<sup>107</sup> Ibid A new French translation from the German proposes ‘rewriting’ for *Umschrift*. See *Littoral*, no 1, pp. 157-167, 1981, Paris.

<sup>108</sup> Masson, J.M. (1985), op. cit., p. 207. *Niederschreiben* means ‘to write down’ or more precisely ‘lay down in writing’, *Niederschrifte* is translated in French as ‘transcriptions’ and in the Standard Edition and in Masson as ‘indications’ or ‘registrations’.

Schema *F* of Freud <sup>109</sup>

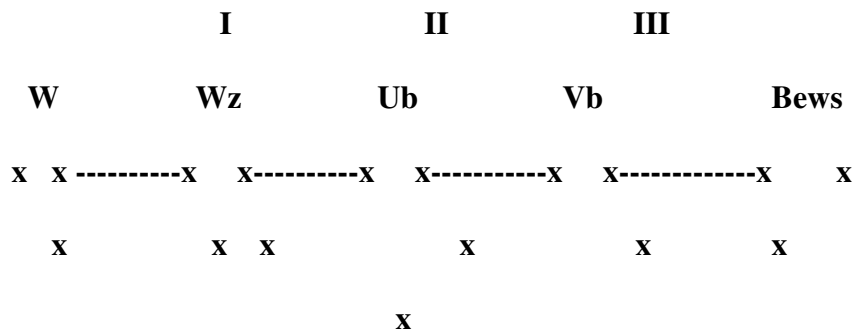

[Fig.7], S. E., **1**, 234; Masson, J.M. (1985), 207

It is noticeable here, that it is by the act of writing that the unconscious memories are formed and that this graphic representation involving space could take a topological manipulation.<sup>110</sup> Indications such as *Umschrift*, (transcription, rewriting), *Niederschrift*, (recording, writing down), *Überschrift*, (registration, over-writing), are indicative of a locus.

Freud's initial inspiration of 'paths of transmission' (*Bahnen*) which he introduced in his paper on *Aphasia* (1891b) and similarly the tracks or 'facilitations' in the 'Project' (*Bahnungen*), was transformed in 'Letter 52' to a hypothesis of layers of writing. Freud was aware that by proposing two or three successive registrations of memory traces, he might be on the verge of constituting 'a new psychology', but his aim was not to rewrite the

<sup>109</sup> Following Vappereau we call this schema 'F' for Freud.

<sup>110</sup> Vappereau applied the topology of Lacan's schema 'R' to Freud's schema 'F' (Vappereau, J.M., op.cit. 18).



‘Project’. In his new representation of psychical space, he was also and foremost concerned with time, with the particular achievements of each psychical era, and with the moment repression occurs, when it does. He was still very much under the influence of Fliess’ theories of psychosexual periods which he translated into mathematical formulas. He attributed ‘the peculiarities of the psychoneuroses’, their symptoms and defences, to a lack of translation of the experience from one epoch to the other. He combined the topographical aspect with the dimension of time and further elaborated the dynamics of the unconscious. ‘Repression’, he said, ...is ‘a failure of translation’ from one era to the other and the cause of this failure is the ‘release of unpleasure.’

*Draft K* was sent earlier and contains many of the same ideas. <sup>111</sup> The neuroses were described there as ‘pathological aberrations of normal psychic affective states’ such as conflict, self-reproach, mortification or mourning. They would correspond to four isolated structures: 1. Hysteria, 2. Obsessional neurosis, 3. Paranoia, and 4. Acute Hallucinatory Amentia. Freud proposes certain preconditions of the pathological defences: that the psychical event is of a ‘sexual kind’, that it occurred before the age of sexual maturity; that it released unpleasure. A normal defence was established first, but, when the memory was reawakened at a later stage, fresh unpleasure was released. Pathological defence was then established as a means to avoid this fresh unpleasure. It is this pathological defence which is called repression. Freud underlines that the neuroses can cause ‘a permanent damage to the ego’. In ‘Draft K’, and in all that early period of his work, Freud follows his theory of sexual trauma: 1) A sexual experience, ‘traumatic and premature’, because it occurs before

---

<sup>111</sup> Draft K, *The Neuroses of Defence* (A Christmas Fairy Tale) was enclosed with Letter 39 of 1 January 1896, (Masson, J. M., op. cit., 162ff; S.E. **1**, 220ff).

sexual (that is genital) maturity, 2) its repression, when its memory is re-awakened by a later experience of the same kind, followed by the formation of a primary symptom, 3) a period of successful defence except for the primary symptom, 4) the return of the repressed, and its struggle with the ego which leads to new symptoms; the illness is established, 5) a stage of adjustment in which the overwhelmed and malformed ego recovers somehow. An early clinical example was given in the 'Project'.<sup>112</sup>

Freud insisted there that the 'specific character of a particular neurosis lies in the fashion in which the repression is accomplished'.<sup>113</sup> In Letter 52 he pursues the same theme adding more questions. Early sexual experiences are accompanied by pleasure in some, and in others by unpleasure. Thus, in an obsessional neurotic, an early sexual event is accompanied by uninhibited pleasure, and, when remembered at a later phase, leads to a compulsion, while in a hysteric subject the early sexual experience releases unpleasure and its awakening at a later stage is accompanied by repression. What makes the difference for Freud is psychic bisexuality to which he gives a biological basis developed on Fliess's theories of sexual substances. It is Freud's explanation as to why, although it is in the character of the sexual experience to cause pleasure, there is psychic unpleasure. Freud borrows Fliess's theory of psychological and sexual phases based on the female period during which there is a release of female sexual substances, but adds a 23 day male period and release of male sexual substance. He argues that the female substance release causes unpleasure, while the male substance release causes pleasure. Then he makes a

---

<sup>112</sup> The case of Emma Ekstein had appeared in Part II of the 'Project' under the heading: 'The Hysterical Proton Pseudos', S.E. **1**, 352-356.

<sup>113</sup> In the ways the repressed ideas return, and in the manner the symptoms are formed. ('Draft K', Masson, J.M., op. cit., 164).

mathematical calculation which proves that psychical development and sexual periods do not coincide. And there is always the effect of deferred action as he underlined in the clinical example of the 'Project'. All this calculation is quite bizarre, but the points made are very significant.

Freud thinks that, although the original sexual experience may initially have yielded some pleasure, its remembrance and repetition causes the neuroses: obsession, with symptoms of compulsion (*Zwang*) in boys, where there was originally an active experience of uninhibited pleasure, and hysteria in girls, because of repression (*Verdrängung*) (for them it had been a passive experience felt as unpleasure). On the other hand, perversion is uninhibited pleasure for which repression was impossible or never occurred.<sup>114</sup>

The word *Zeichen* used by Freud for the unconscious registrations means literally: sign, mark, character or symbol, and it is both a noun and a verb. This linguistic reference is lost in both English translations, as it becomes 'indications'. The French translators<sup>115</sup> chose the word '*signes*' (signs) which is a clear reference to the linguistic sign. The first unconscious transcription is made of perception signs (*Wahrnehmungszeichen*). Lacan finds here the signifiers, and their synchronic arrangement, underlined by Freud as 'association by *simultaneity*'. In the second transcription, *Ub* (*Unbewußt*) traces 'would perhaps correspond to conceptual memories'. They are arranged following other, perhaps 'causal

---

<sup>114</sup> *Urverdrängung*, on the other hand, will later become the term for the original repression of a much more fundamental pleasurable experience, which Lacan referred to as *The Thing*. (See the comments of the translators of Letter 52 in French, Mayette Viltard and Anne Porge, in *Littoral*, 1, 1981, 164-167).

<sup>115</sup> Cf. notes 101 and 106 above.

relations'.<sup>116</sup>

'W [*Wahrnehmungen* (perceptions)] are neurones in which perception originate, to which consciousness attaches...

'Wz [*Wahrnehmungszeichen* (indication of perception)] is the first registration of the perceptions; it is quite incapable of consciousness and is arranged according to associations by simultaneity.

Ub [*Unbewusstsein* (unconsciousness)] is the second registration arranged according to other, perhaps causal, relations. Ub traces would perhaps correspond to conceptual memories (*Begriffserinnerungen*) equally inaccessible to consciousness.

Vb [*Vorbewusstsein*] (preconsciousness)] is the third transcription, attached to word presentation and corresponding to our official ego . . . this secondary *thought consciousness* is subsequent in time and is probably linked to the hallucinatory activation of word-presentations, so that the neurones of consciousness would once again be perceptual neurones and in themselves without memory.'<sup>117</sup>

Freud produces also two tables. In the first he shows the discrepancies between psychical and sexual periods and in the second the different registrations of signs (*Zeichen*) are placed chronologically within the different structures.

---

<sup>116</sup> Masson, J.M., p. 208. Lacan declares: 'we can immediately give to these *Wahrnehmungszeichen* their true name of *signifiers*'. He underlines that Freud does not know that he is saying this fifty years before the linguists or that when he tells us, that they are constituted by simultaneity, this is nothing else than the first law of the signifying association, *synchrony*. In Letter 52, Freud refers to the second registration of Ub (unconscious) conceptual memories as arranged 'according to other, perhaps causal relations'. Lacan finds in that an allusion to 'the causal gap' in the structure of the unconscious. Association by similarity, contrast and similitude, which is the rule in the chronologically later systems, would correspond to the second law of association, *diachrony*, essential for the constitution of metaphor, as he clarifies (Lacan, J., 1964, *The Four Fundamental Concepts of Psychoanalysis*, Seminar Book XI, 1981, 46).

<sup>117</sup> Masson, J.M., op.cit., 207-208. Freud's schema shows W, Perception, on the one end of this band and Bew, Consciousness, on the other, and Freud's idea of a meeting between Perception and Consciousness, suggests that there is a continuum. This topological transformation was done by Vappereau in his study of the topological surfaces.

Freud's first table of the registration of signs

Wz	Wz + Ub	W + Ub + Vb	Ditto
Up to 4	Up to 8	Up to 14-15	
Hysteria current	Compulsion	Repressed in Wz	
Obsessional Neurosis	Current	Repressed in Wz	
Paranoia	-	Current	Repressed in Vb indications
Perversion current	Current	Compulsion (current)	Repression impossible or not attempted

Freud's second table of the dissymmetry between psychological and sexual periods

Psych.	1a		1b	II	III
Sex		1		II	III

Ibid.

### K. 'The Interpretation of Dreams', Chapter VII (1900a)

The study of the dream, a complex psychological phenomenon still retaining much of its

enigma, was a unique opportunity for Freud to investigate further the workings of the psychic apparatus, and to conclude with a new construction for his first topography. We find it in Chapter VII of ‘The Interpretation of Dreams’ (1900a), in the section about regression. The idea of writing prominent in ‘Letter 52’ is being replaced here by the idea of the psychical apparatus constructed as a complex optical instrument resembling a microscope or a camera. What is important is the consolidation of a certain ‘psychical locality’ which is not to be confused with any anatomical localization. Freud referred once more to Fechner: ‘In the course of a short discussion on the topic of dreams, the great Fechner (1889, 2, 520-1) puts forward the idea that the scene of action of dreams is different from that of waking ideational life’.<sup>118</sup>

This new construction occupies only a few pages in this vast book, but it has always been considered as a fundamental part in Freud’s formalization of the psychical apparatus, the final diagram for his first topography. Freud will use here for the first time the term *Instanzen*, instances, ‘agencies’, for the various psychic systems. The *spatial* order of these instances is crucial, as this apparatus now has a direction. They are also arranged according to a temporal sequence; the term ‘ $\psi$ - systems’ is still in use.<sup>119</sup>

---

<sup>118</sup> Freud, S. (1900a), S.E. 5, 536. A long reference to Fechner’s passage also appeared in the first chapter of ‘The Interpretation of Dreams’, section E (S.E. 4, 48). The citation is from Fechner’s *Elemente der Psychophysik* (1889). Freud talked of ‘the other scene’, ‘a different psychic territory the map of which he was preparing’ (Letter to Fliess of February 9, 1898, Masson, J.M., op. cit., 299)

<sup>119</sup> Freud, S., (1900a), S.E. 5, 537.

The general schematic picture of the psychical apparatus

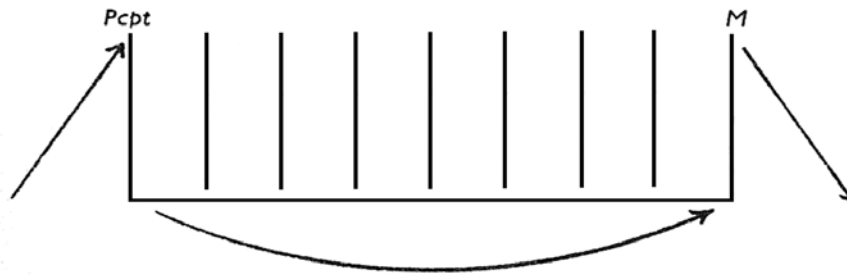

'Fig. 1', Freud, S. (1900a), S.E. 5, 537

Instead of inscriptions, Freud has in mind here a 'reflex apparatus' and 'reflex processes' which form 'memory-traces' and constitute unconscious memory. The term he uses for these traces organized in strata is '*mnemic* elements' or '*mnemic* system'. He also differentiates the perceptual stimuli on the left extremity of the apparatus (*Pcpt*), as another system which retains no memory, from the first memory-traces of those perceptions, *Mnem*, which constitute the first unconscious traces like Letter 52's *Wahrnehmungszeichen*. The other extremity of the apparatus is the gateway to motor discharge (*M*). In the space between the two, three or more series of *mnemic* traces are arranged according to certain logical and chronological rules, first *Mnem.*, according to associations by *simultaneity* in time, then, *Mnem 1*, and *Mnem 2*, according to *similarity*, to logical and causal rules, all unconscious.<sup>120</sup>

<sup>120</sup> Ibid., 539.

## Second diagram of the psychological apparatus

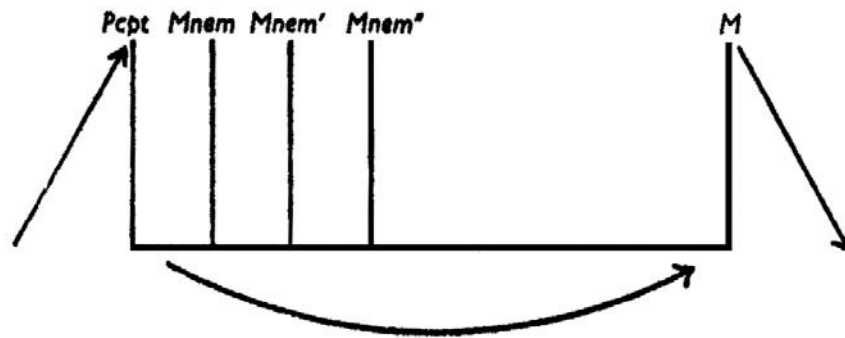

'Fig. 2', Freud, S. (1900a), S.E. 5, 538.

Memory traces have no quality, while perceptions provide qualities of sensations. They are without memory, while memory-traces are unconscious to start with, and some remain so, while some become conscious. Memory and consciousness are mutually exclusive, as Freud will say.<sup>121</sup>

Freud refers to another important consequence of the structure of the apparatus. Dreams, as he says, were possible, because of the existence of a distinct psychical agency being situated just before the access to consciousness, the critical agency or censorship. This, as he underlines, is the second psychical system, necessary for the formation of dreams (the first is that of the memory-traces). This critical agency decides what will be excluded from consciousness. It is a barrier, a *screen*, and behind it lies the Unconscious proper (*Ucs*),

<sup>121</sup> Ibid., 540. He will add a note in 1925 that 'consciousness actually arises instead of the memory-traces', as he wrote in his 'Note upon the "Mystic Writing-Pad"' (1925a).



while on the other side, beyond it, is the Preconscious (*Pcs*).<sup>122</sup>

The complete diagram of the psychological apparatus

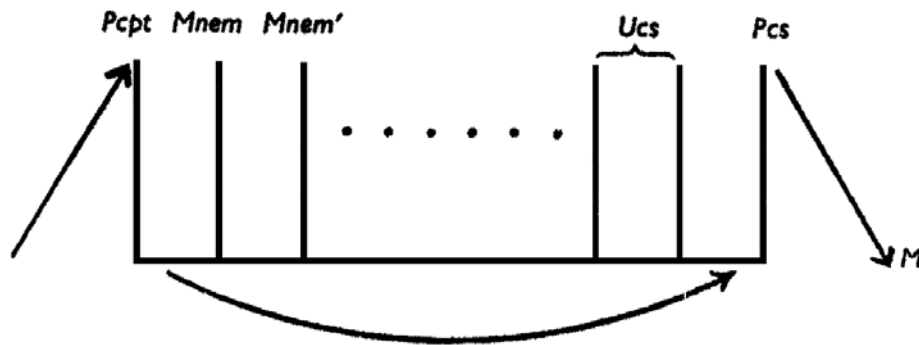

'Fig. 3', Freud, S. (1900a), S.E., 5, 541

We end thus with two or three layers of memories, (1) the *unconscious traces of perceptions*, which are occurring by simultaneity (*Mnem, Mnem'*) followed by (2) Conceptual memories (*Begriffserinnerungen*) constituting the *unconscious proper (Ucs)* and, 3. The *preconscious (Pcs)*. Consciousness (*Cs*), does not really become a separate system but rather an extension of the *Pcs*.

<sup>122</sup> The implication of this statement could be that censorship belongs to the unconscious system itself. But Freud places censorship in the preconscious immediately after.

Freud will note later that the perception system (*Pcpt*) which is at the beginning of the Diagram and consciousness(*Cs*) at the other end of it are joined potentially as a third system (*Pcpt/Cs*), which suggests a topology and a transformation of the surface of recordings.

We note that Freud gave a direction/vectorialization to the psychological process, which allowed him to talk about regression in the dream (in reversing the direction). He also underlined that it was from the *unconscious* system that the dream-wish stemmed, but that the dream-thoughts belonged to the *preconscious* system to the right of the apparatus. There was therefore a forward and a backward movement from the one end to the other. At the end, next to the preconscious system, motility (*M*) was placed and not consciousness, but it was said that access to consciousness was obtained via the preconscious. Finally a screen operated between the unconscious (*Ucs*) and the *Pcs/Cs* system. It was called the critical agency which we know as censorship in the dream, as Freud underlined, a function which he attributes here to the *ego*. Without being named the ego was meant to be the equivalent of the preconscious.

Censorship barred the dream-thoughts from access to consciousness. Attention and censorship had a similar function here which was to allow some of the ‘excitatory processes’ to enter consciousness and the motor end (*M*). A note was added here by Freud in 1919 <sup>123</sup> to indicate that the layout of his systems could only mean that consciousness met with perception at the other end, and thus *Pcpt=Cs*.

---

<sup>123</sup> Freud, S. (1900a), op. cit. 541, n. 1.

This idea was taken up again in ‘The Ego and the Id’ (1923b), and repeated in Lecture XXXI of the ‘New Introductory Lectures to Psychoanalysis’ (1933a). Thus the linear apparatus could possibly be transformed to the topological surface of the Moebius strip.<sup>124</sup>

---

<sup>124</sup> While dream-thoughts can overcome censorship and reach the preconscious and consciousness and this is a *progressive* direction of the apparatus, other dreams have a hallucinatory character which is only possible through *regression* which can reach as far as the perceptual end of the apparatus. Thus a revival of the perceptual images, the raw material of the *mnemic* traces, as Freud calls it, is possible in dreams (Op. cit., 542-543).

## CHAPTER 2

### THE INSERTION OF NARCISSISM

#### A. Introduction

Freud's theoretical developments in the 'Project' (1950a[1895]) presented the psychical apparatus as a structure, a symbolic articulation of the traces left by the experiences of satisfaction and/or pain on the primitive psyche, with the appearance in its core of an organization called 'ego' (*Ich*), formed in these circumstances to safeguard the equilibrium of the system and using, for that purpose, inhibition and primary defence against unpleasure, or, indeed, against excessive pleasure becoming unpleasure, because of adverse circumstances. I claimed that this 'ego' was, in a certain way, both the underlying subject of the 'wishful attraction' (desire) and the defensive agent of 'the inclination to repression'.<sup>1</sup>

After the 'Project' was abandoned, Freud developed another theory of the psychic apparatus, the idea that our psyche is laid down in layers of recorded *signs*. He first referred to 'files of memories arranged in a threefold order' in 'Studies on Hysteria'.<sup>2</sup> In Letter 6 December 1896 to Fliess known as 'Letter 52', he gave this idea a more precise and formal development. Later, in Chapter VII of 'The Interpretation of Dreams' (1900a) he presented a modified version of this 'first topography'.<sup>3</sup>

---

<sup>1</sup> *Ich*, in the 'Project' is not, as Strachey argues, a coherent structure, but rather an undivided subject.

<sup>2</sup> Freud S., (1895d), Part IV, Psychotherapy of Hysteria, S.E. 2, 288: 'The psychical material in such cases of hysteria presents itself as a structure in several dimensions which is stratified in at least three different ways.'

<sup>3</sup> Cf. this thesis Chapter 1, Section J.

The structural apparatus in the ‘Project’ had involved a quantitative parameter (  $Q\eta$ ) which presented Freud with a theoretical problem. A quantum of psychological excitation, Freud’s sexual affect from the ‘Studies on Hysteria’ (1895d), was at stake in the excessively intense idea, and was responsible for the formation of symptoms. The quantitative element in the psychological representation was developed theoretically as an ‘affect’ in Freud’s metapsychological text ‘The Unconscious’ (1915e),<sup>4</sup> while, on the other hand, the concept of the ‘sexual drive’ itself received its theoretical elaboration earlier in the ‘Three Essays on the Theory of Sexuality’ (1905d) as *Libido*.<sup>5</sup> The ‘sexual affect and ‘psychic libido,’ both first appeared in Freud’s Draft E , *How Anxiety Originates* (an undated Letter, envelope of June 6, 1894 may belong to it). As Freud argued there, ‘in anxiety neurosis there must be a deficit to be noted in sexual affect, in psychic libido’, while, on the other hand, ‘psychic erotic tension accumulates in melancholia’.<sup>6</sup> This is why anxiety neurosis was classified amongst the ‘actual neuroses’.<sup>7</sup>

---

<sup>4</sup> Cf. this chapter, this thesis pp...

<sup>5</sup> Freud had found increasingly difficult to determine this concept throughout his work. In this respect, it is useful to remember that, when the concept was introduced, Freud defined it as ‘energy, quite distinct from somatic excitation.’ Laplanche, and Pontalis argued that the role of *libido* is that of a ‘quantitative concept increasingly emphasized by Freud’, while ‘qualitatively’ it cannot be reduced to ‘an indeterminate mental energy’, similar to the one Jung advocated. (See Laplanche, J. and Pontalis, J.-B., *Vocabulaire de la Psychoanalyse*, Paris 1971, *The Language of Psychoanalysis*, London, 1988, 239). Both *sexual affect* and *libido* in this ‘first Freud’ seem to be placed as concepts in the psychological space. However, *Libido* represents the mental side of the sexual drive, its ‘dynamic manifestation in mental life’ in the ‘second Freud’ (see ‘Two Encyclopaedia articles’ (1923a [1922]). It encompasses ‘all the manifestations of those instincts . . . comprised under the word of love’ in the ‘third Freud’ (Freud, S., 1921c, S.E. 18, 90).

<sup>6</sup> Masson, J.M., op.cit. (1985, 81. In his work ‘On the Grounds for Detaching a Particular Syndrome from Neurasthenia under the Description “Anxiety Neurosis” (1895b, [1894]), Freud argued that when this quantity (libidinal, sexual) cannot cross the boundaries between the somatic and the psychological and become a psychological representation, it accumulates as purely somatic excitation, namely as *anxiety*. This was Freud’s *first theory of anxiety* (Freud, S., op. cit., S.E. 3, 107-108).

<sup>7</sup> Freud’s terms are *Angstneurose, Aktualneurosen*. The concept of *libido* was introduced in Freud’s two papers on anxiety neurosis (1895b and 1895f). As developed in the first of the ‘Three Essays’ (1905d), it formally defines the ‘sexual drive’ (Strachey’s ‘instinct’). In the third of the Three Essays, in the section added in 1915, it is described as ‘a quantitative variable force which could serve as a measure of processes and transformations occurring in the field of sexual excitation (Freud, S., (1905d), S.E. 7, 135 and 217).

Freud's 'Project' composed in 1895 was written after the publication of the first paper on anxiety neurosis mentioned above (1895b[1894]) and a year after Draft E *On Anxiety* (1894). His Draft G *Melancholia* was also written earlier (undated, perhaps January 7, 1895). It contains 'the schematic diagram of sexuality', showing the boundaries between the somatic and the psychical excitations in which a sensation travelling along and back, is transformed from somatic sexual excitation, *somatische Sexualerregung*(sS,) into psychical tension, *psychische Sexualspannung* (ps.S), and *Vollust* (V), pleasure.<sup>8</sup>

'The Schematic Picture of Sexuality'

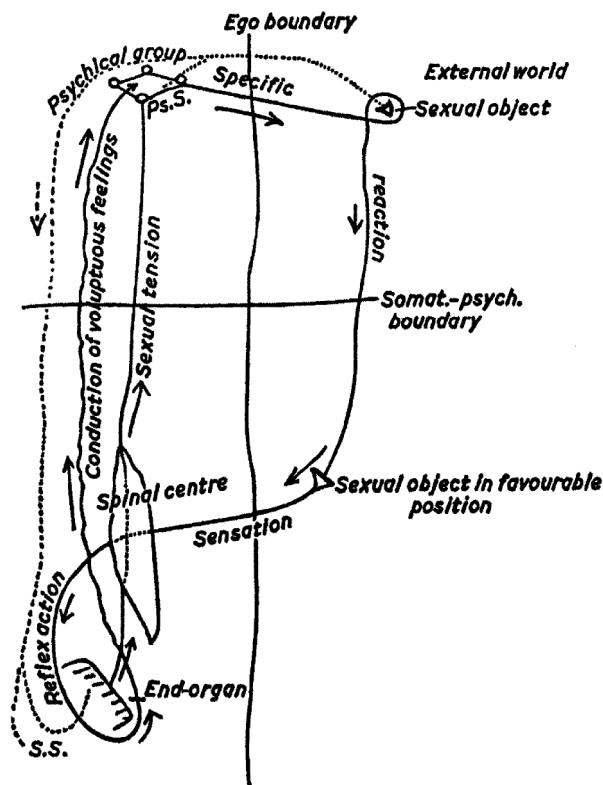

Freud, S., (1950a [1895]) Draft G *Melancholia*, S.E. 1, 202; Masson, (1985), 100

<sup>8</sup> Masson, J.M., 1985, op. cit., 100. Cf.: This thesis, Chapter 1, p. 57.

Freud's 'first topic'<sup>9</sup> completed in the 1900s, left unanswered questions about the destinies of excessive quantities and the precarious equilibrium between 'ego' and pleasure (unpleasure) for the psychical subject, that were not to be treated theoretically for a long time. In his paper 'On Narcissism; an Introduction' (1914c), Freud confessed that, for years, he was rather preoccupied by the definition of neurotic structures, their symptoms and other unconscious formations, in his works, the 'Psychopathology of Everyday Life' (1901b), and 'Jokes and their Relations to the Unconscious' (1905c) for instance. The study of the relation of the drives with the destinies of a regulator such as the 'ego' of the initial structural theory was pushed to the background for about ten years. But in his studies on the role of sexuality in determining the neuroses (and not only in the 'Three Essays' of 1905), in clinical papers and lectures, Freud's unresolved questions on the experiences of satisfaction or pain, especially on their remainders, affects and their effects on the psychical subject (*Ich*)<sup>10</sup> were emerging at times.

In the fourth edition (1915) of 'Three Essays on the Theory of Sexuality', he adds his page on the 'Libido Theory' (third essay, third section)<sup>11</sup> which was inspired by the ideas of 'On Narcissism: an Introduction' (1914c). This is to say that after he introduced his theory of Narcissism, Freud was able to return properly to the theoretical questions of the first period and produce an important development in the direction of both, the libido theory and the *Ich*.

---

<sup>9</sup> An unorthodox term in English, inspired by the French '*topique*'.

<sup>10</sup> We will from now on take as equivalent the terms 'psychical subject', another unorthodox term, and *Ich*. But the debate on the subject continues throughout the thesis.

<sup>11</sup> Freud, S., (1905d), S.E. 7, 217-218.

Between the first Topic and the text ‘On Narcissism’ two papers make the transition to this ‘second Freud’(1914-1918), the paper known as ‘Formulations on the two Principles of Mental Functioning’ (1911b) and the ‘Psychoanalytic Notes on an Autobiographical Account of a Case of Paranoia’ (1911c). In the former, the unconscious psychical processes are conceptualized as an *Ich* governed by the ‘pleasure(and unpleasure) principle’ ( *Lustich, Unlust, Lust Prinzip* ), from which a ‘reality-ego’, governed by the ‘reality principle’ (*Realich, Realität Prinzip*), emerges as a successor and a guarantor. The original auto-erotic *Ich*, the organ of hallucinatory satisfaction, was thus replaced ‘albeit not perfectly’, by *Realich*.

‘Formulations on the two Principles of the Psychical Event’<sup>12</sup> (1911b) is an intermediate step towards the metapsychological papers, especially ‘Drives and their Vicissitudes’ (1915c). As for the Schreber case, published that same year (1911c), it is the precursor of Freud’s paper ‘On Narcissism; an Introduction’ (1914c).<sup>13</sup> This ‘second Freud’ develops the distinction between ego interests, or drives of self-preservation ( *Icherhaltungstrieb* or *Ichinteresse*), and the sexual drives, which he already established in his analysis of the Schreber case. But, he also introduces a distinction within the sexual drive itself (Strachey’s ‘instinct’), between ego-libido and object- libido, which he makes thanks to the introduction of his own theory of narcissism. It is with the development of a ‘new psychical

---

<sup>12</sup> For other translations of *psychisches Geschehen* Cf. : this thesis, Chapter 2, p. 85 note 16 and p. 88, note 23.

<sup>13</sup> *Lustich* is pure pleasure, while *Realich* seems to replace here the old function of attention, which, in the ‘Project’, was the responsibility of a third group of neurones,  $\omega$ , using the indications of reality (*Realitätszeichen*). The same processes are discussed again by Freud in ‘Drives and their Vicissitudes’ (1915c). In the latter, however, it is *Lustich* which is formed out of an original *Realich*, which is a paradox, as we are going to develop.



action’, the libidinal cathexis of *Ich*, that a different, modified ego can be introduced. In that formation Lacan saw the confirmation of his own *Mirror Stage* (1949).<sup>14</sup>

The theme of the ancient myth of Narcissus had been evoked by Freud in his analysis of Leonardo da Vinci (1910c).<sup>15</sup> This case together with the Schreber case led him to insert the stage of ‘narcissism’ between autoerotism and object-libido in the structure of psyche; with it he can approach clinical phenomena as disparate as the psychoses (schizophrenia, melancholia, paranoia), homosexuality and, the psychology of love. He could confront ‘the new clinic’ of his time, as it was emerging in Berlin and Zurich, with Bleuler, Abraham and Jung.

As we will argue, *Lustich* of ‘Formulations’ (1911b) has affinities with *Idealich* of ‘On Narcissism; an Introduction’ (1914c), but different ancestors. As for the two terms *Ichideal* and *Idealich*, which Freud seemed to use indiscriminately in the latter, they will be distinctly developed by the later Freud.

The second chapter traces Freud’s trajectory on the question of *Ich*, from ‘Formulations’ (1911b) to ‘On Narcissism’(1914c) and some further developments through the first three metapsychological papers, ‘Drives and their Vicissitudes’ (1914c), ‘Repression’ (1915d), and ‘The Unconscious’ (1915e), where a systematisation of new themes leads Freud to a reformulation of his ‘first topography’.

---

<sup>14</sup> Lacan, J., *Ecrits* (1966), *The Mirror Stage as Formative of the I Function as revealed in Psychoanalytic Experience*, 2006, London (Fink, 75-81).

<sup>15</sup> The term *Narzissismus* had been used in German Psychiatry by Havelock Ellis, in his *Psychologia Sexualis* (seven volumes between 1910-1928) and by Näcke. Freud’s term is *Narzismus*.

## B. 'Formulations on the Two Principles of Mental Functioning.'<sup>16</sup>

The original ego (*Ich*) in the 'Project' emerged as a result of the opposing trends of 'wishful attraction' –desire- and inclination to repression following the command of the pleasure principle in the psychical processes. Its task was to deal with the constant pressure coming from the internal stimuli, from the 'demands of life', as Freud underlined. One could say, with Strachey, that these 'urgent needs' were the precursors of the drives. They used some of the constant and low internal *Q<sub>n</sub>* pressure:1) for the purposes of bringing about the 'specific action' leading to discharge or satisfaction and 2) to avoid the repetition of any experience which could cause pain or unpleasure leading to harm for the ego .<sup>17</sup> The ego's function was then inhibition or primary defence. Freud had recognized defence as a major operator in all his 1890s papers on the 'Neuropsychoses of Defence', and especially in the 'Studies on Hysteria'(1895d).

Around the 1910s some new 'formulations' were brought forward by Freud, which concern both the mechanism and the aim of the psychical apparatus. The psychical processes were this time approached from the point of view of their relation to 'external reality'. Janet had singled out a defence mechanism he called 'turning away from reality'<sup>18</sup>, common in

---

<sup>16</sup> Freud, S. (1911b), S.E. **12**, 218ff. ' *Formulierungen über die Zwei Prinzipien des psychischen Geschehen*' was translated from the German by French psychoanalyst Claude Conté (in Internal Document of the *Ecole Freudienne de Paris*). He proposed '*activité psychique*' for '*psychisches Geschehen*'. The other meanings of *Geschehen* we found are: 1) happenings, events and 2) process, action. The work in German appeared first in the '*Jahrbuch für psychoanalytischen und psychopathologischen Forschungen*' in 1911 and subsequently in '*Gesammelte Werke*', VIII, pp. 230-238.

<sup>17</sup> Freud, S., (1950a), the 'Project' Part I, S.E. **1**, 297 and 323. The ego was meant to 'interfere with passages [of quantity] which on the first occasion occurred in a particular way [i.e satisfaction or pain].

<sup>18</sup> Pierre Janet used the expression '*perte de la fonction du réel*', but, as Freud remarks, 'he did not make the connection of this disturbance with the fundamental determinants of neurosis' (Freud, S., 1911b, S.E. **12**, 218).

neurosis but also, in some forms of psychosis. Freud stated his intention ‘to bring the psychological significance of the real [external world] into the structure of our theories’. In his opening lines he stated: ‘We have long observed that every neurosis has as its result and probably therefore as its purpose a forcing of the patient out of real life, an alienating of him from reality’ (*Wirklichkeit*).<sup>19</sup>

From the start, the unconscious, the more ancient and primary psychological processes, which interest psychoanalysis, ‘obey a superior tendency’ which we recognize as ‘the pleasure-unpleasure’ principle. These processes aspire to a ‘gain of pleasure’ (*Lustgewinn*). Psychological activity ‘turns away’ from acts which can cause unpleasure. This is the mechanism we call repression (*Verdrängung*). Pleasure is what we strive towards in our awakened life and in our dream activity. Freud describes how in the ‘state of psychological rest’ an initial ‘Lustich’ was destroyed by ‘the peremptory demands of internal needs’ (*Bedürfnisse*). Then, in the state of ‘urgency’, in other words, in ‘the state of desire’, (*Begierdezustand*) what was wished for was ‘represented in a hallucinatory manner’, as it still happens in our dreams. <sup>20</sup> Sleep presupposes a ‘denial’ (*Verleugnung*) of external reality, as Freud underlines.

---

<sup>19</sup> In this instance and in three more instances in this paper he uses the term, *Wirklichkeit*. It means literally ‘factual reality.’ Another occurrence of the term in the same text: ‘Neurotics turn away from reality (*Wirklichkeit*), because they find it unbearable’ (Ibid.) The term has been used rarely by Freud. It seems to have some of the weight of Lacan’s *real*, we could say. In all other occurrences, Freud used the term *Realität*, a term some think he borrowed from Brentano’s theory of psychological reality.

<sup>20</sup> When this happened, whatever was thought of (*das Gedachte, das Gewünschte*) was simply represented in a hallucinatory manner, just as still happens today with our dream thoughts every night.’ (Freud, S., 1911b, S.E. **12**, 219; Freud., S, G.W. **VIII**, 231).

In order to avoid disillusionment and unnecessary harm from precipitated action, the psychological apparatus had to form a conception of the ‘real circumstances’ in the external world, and to ‘make a real alteration of them’. This is how the reality principle came about. These operations resulted in a development of *Ich* (the primitive psychological apparatus) from *Lustich* to *Realich* and the delimitation of a new psychological space, with an inside and an outside, an ‘internal’ and an ‘external’ reality.<sup>21</sup>

As external reality becomes more important, attention is turned to sensory qualities and their conscience. A system of notations, of indications ( *Merken*) is formed, creating a data basis for conscious memory. In ‘Formulations’(1911b) Freud starts from the hypothesis of an original psychic organisation as closed to the outside world, a ‘fictional organisation’, a *Lustich*, which can only function thanks to mechanisms such as projection or rejection to the outside world, mechanisms which are ‘the correlates of *repression*’. This autistic form of existence – he borrows the term from Bleuler- would, however, have to be coupled with the mother’s care. Hallucinatory fulfilment (*Erfüllung*) would be sought under the dominance of the pleasure principle. But, ‘as soon as the attachment to the parents was abandoned, the *pleasure principle* was superseded by the *reality principle*’.<sup>22</sup>

---

<sup>21</sup> Freud talks about the progression from the original, but fictional, *Lustich* to *Realich* in terms of acceptance, rather than adaptation: ‘What was represented now was no longer what was agreeable, but what was real, even if it happened to be disagreeable.’ (Ibid.)

<sup>22</sup> Ibid. This progression was not peaceful; it resulted in a breaking-up, a splitting-off within *Ich*, part of which identified to the object which brings pleasure ( *Lust*), *Lustich* , while *Unlust* was expelled outside, became what is *not-Ich*. Freud will develop the idea further in ‘Drives and their Vicissitudes’ (1915c) and later in his text ‘Negation’ (1925h).

Repression, ‘which kept part of the emerging representations outside cathexis, because of unpleasure’, was replaced by ‘impartial judgment’ (*Urteilsfällung*). Discharge by action was suspended as a result of the thought processes.<sup>23</sup>

However, after the establishment of the reality principle ‘a certain activity of thought was split from the rest . . . and remained submitted to the sole pleasure principle’ · This thought-activity was fantasizing (*Das Fantasieren*) which Freud found in children’s play and day-dreaming. More importantly Freud will underline the long suspension in the development - and the non-adaptation to the new master, the reality principle- of the sexual drives, which remain auto-erotic up to the start of the process of ‘finding the object’ again (*Objektfindung*), but then, they succumb to a long interruption, due to the latency period.

Although Freud presents new defence mechanisms which have to do with the formation of that external space we mentioned above – these are called ‘rejection’ (*Verwerfung*) and/or ‘denial’ (*Verneinung*)- he still keeps ‘repression’ as the main defence mechanism against sexual satisfaction, it maintains the activity of fantasy outside the realm of reality. This mode is the rule ‘in the country he is exploring’, i.e. the neuroses, but it regularly fails: ‘This is the weak point of our psychical organization, which can be used to bring those thinking processes which previously had become rational back under the dominance of the pleasure principle’.<sup>24</sup>

---

<sup>23</sup> We followed closely Conté’s translation (cf. our note 16, this Chapter, this Thesis) which seems to give more the flavor of the original: ‘Thinking was originally probably unconscious, as long as it was based on the function of simple representation and was devoted to the relations between impressions of objects. It only acquired the perceptive qualities of conscience later, when it became linked to verbal residues’ (Conté, C., ‘Formulations’ (1911), a new translation from the German, Internal Document of the *Ecole Freudienne de Paris*); Freud, S., (1911b), S.E. 12, 221.

In this new configuration, *Lustich* ‘can do nothing but wish (*wünschen*), work for a yield of pleasure (*Lustgewinn*) and avoid unpleasure’, while ‘*Realich* has no other aim than to seek what is useful (*nützen*) and to guard itself against damage’. At the very end, the reality principle only safeguards the dominance of the pleasure principle. Subsequently, Freud links *Ichtriebe* or *Selbstverhaltungstriebe*, with the activities of consciousness (*Bewußtseinstätigkeiten*), while *Sexualtriebe* retain their ‘imaginary and momentary’ autoerotic satisfaction. ‘In fact (*im Wirklichkeit*), the replacement of the pleasure principle by the reality principle does not mean the destitution (*Absetzung*) of the pleasure principle, but only its guarantee’.

‘The strangest characteristic of [the] unconscious (repressed) processes, to which no [the] investigator [himself] can become accustomed without the exercise of great self-discipline [after the greatest effort], is due to their entire disregard of reality-testing [springs from the fact that for those processes the proof of reality (*Realitätsprüfung*) is without validity]; they equate reality of thought with external reality, [reality of thought (*Denkrealität*) is equal with external reality] (*äussere Wirklichkeit*), and wishes with their fulfilment [desire (*Wunsch*) is equal with realization], with the event [itself], just as it happens automatically [as it was undoubtedly the case] under the dominance of the old pleasure principle’.<sup>25</sup>

---

<sup>24</sup> Freud, S., 1911b, S.E. 12, 223. We read earlier about the correlate of repression, namely projection or better, rejection to the outside. ‘These structures are only the correlate of repression, they treat unpleasant internal excitations as if they were external, and thus drive them out into the outside world.’ (*Diese Einrichtungen sind nur das Korrelat der Verdrängung, welche innere Unlustreize so behandelt, als ob sie äussere wären, sie also zur Aussenwelt schlägt.*’, Freud, S., G.W. VIII, 232). As Lacan pointed out, the importance of this paper does not lie in the developments on the structure of fantasy.

<sup>25</sup> Freud S., (1911b), S.E. 12, 225. My translation from the German in brackets. (G.W. VIII, 235) with the help of Conté’s French translation. Strachey has invariably translated the German *Realitätsprüfung* as ‘reality-testing’. As we know the genitive in German can mean either ‘of’ or ‘by’. Thus, the authors of a recent French translation of Freud’s ‘Negation’ (1925h) (*Die Verneinung*) where the same word appears, they proposed ‘a process of testing reality’ for it. They argued that Freud is more likely to talk about ‘testing reality’ than ‘testing by reality’. *Denkrealität* (reality of thought) and *äussere Wirklichkeit* (external reality) are difficult to distinguish, because of the influence of fantasy (M. Viltard, E. Legroux, C. Toutin-Thélier, *L’Unebévüe*, No 7, Supplement, ‘Negation’, Paris, E.P. E. L., 1995-1996).

Freud ends his development with a dream, which still holds its enigma. A man who had previously nursed his father during a long and fatal illness had the following repetitive dream for a few months after he died:

‘His father was alive once more and he was talking to him in his usual way [as before]. But he felt it exceedingly painful [At the same time, he felt with the acutest pain], that his father had really died [was already dead], only without knowing it [however, but that he did not know it]’.<sup>26</sup>

As Freud argues, there is no other way of understanding this otherwise absurd, little dream than by adding, ‘according to his wish’, or ‘as the dreamer wished’ after the words: ‘that his father had really died’. His father was already dead and that was the dreamer’s wish. We have here, Freud adds, the familiar example of ‘self-reproaches after the loss of someone loved’. It is complicated by the infiltration of the infantile wish for the father to be dead. Freud concludes that the missing, repressed dream-thought could be completed as follows:

‘It was a painful memory for him that he had been obliged to wish for [wished] his father’s death [the death of his father] (as a release) [as deliverance], while he was still alive, and, how terrible it would have been if his father had had any suspicion of it [wouldn’t that be dreadful had the father suspected it]’.<sup>27</sup>

For Lacan, the significance of the work lies not in what it says about the fantasy, but in what it says about the insistence of desire in the Unconscious. We also need to point at the new formulations on the processes of defence which herald the further developments of this question and their effects on the choice of neurosis and the *Ich* later in Freud’s work.

---

<sup>26</sup> Ibid.; G.W. VIII, 238.

<sup>27</sup> Ibid. In his Seminar *Desire and its Interpretation*, (1957-58, non-published), sessions of 3 and 10 December 1958, Lacan used Freud’s dream when he constructed his graph of desire. He placed the phrase ‘that the father was dead’, on the level of the unconscious enunciation and said that it was the proof that the [dead] father is unconscious (does not know), and on the level of desire he placed the missing phrase ‘according to his wish’.

### C. The imaginary function of Ich, narcissism.

In his biography of Freud, Jones relates how Freud first talked about narcissism as a necessary stage between auto-erotism and object-love in a meeting at the Vienna Psychoanalytical Society in 1909. However, auto-erotism and narcissism were used as equivalent terms in his study of ‘Leonardo da Vinci’ (1910c). The term ‘narcissistic object choice’ appeared in the 4<sup>th</sup> Edition of the ‘Three Essays’ (1905d), in a note added in 1915. He already used the concept of narcissism to explain the homosexual choice of a love-object in the Case of Schreber (1911c, S.E. 12, 60-61), in section III of his ‘Psychoanalytic Remarks’.<sup>28</sup> It became the missing link for extending his libido theory to psychosis. When in 1914 he published ‘On Narcissism: an Introduction’ (1914c), a work composed only within a week, during a holiday, in Rome, the premises were already in place. It was an important theoretical advance concerning the ‘ego’, which can now be itself an object of libidinal cathexis; it was also a renewal of the importance of his theory of libido for psychoanalysis.<sup>29</sup> A new distinction was made between ‘ego-libido’, and ‘object-libido’. Another important point concerned the formation of the ideal. As Freud underlines, the process of idealization is taken within ‘the sphere of ego libido’. In ‘On Narcissism’, Freud used the terms ‘ideal ego’ ( *Idealich*), and its counterpart, ‘ego ideal’ ( *Ichideal*) indiscriminately, as formations of the lost narcissism of childhood. The role played by the

<sup>28</sup> Freud, S., (1911c), S.E.12, 60: ‘Recent investigations have directed our attention to a stage in the development of the libido which it passes through on the way from auto-erotism to object-love. This stage has been given the name of narcissism.’

<sup>29</sup> Freud’s original title *Zur Einführung des Narzissismus*, (1914), G.W. X, 138-170, suggests rather an insertion, than an introduction, as the English translation has it, S.E. 14, 73, the insertion of a stage in the libidinal development. This is confirmed by Freud himself in *‘Totem and Taboo’* (1913 [1912-13]), section III, as love of oneself and omnipotence of thoughts. S.E. 13, 88-89. In 1911, Otto Rank published his own *‘Ein Beitrag zum Narzissismus’*, A Contribution to Narcissism (in *Jb. psychoan. psychopath. Forsch.*, 3, 401).



external object, although signalled, was secondary here, and only came to the fore later, first with the developments of ego identifications in ‘Mourning and Melancholia’ (1917e), then in Chapters VIII and XI of ‘Group Psychology and the Analysis of the Ego’ (1921c) and of course, in ‘The Ego and the Id’ (1923c).

In a note, Strachey points out that, in as much as the theory of the Freudian *Ich* is concerned, the work ‘On Narcissism’ is a transition from the more imprecise meaning of ‘self’, to which corresponded the Freudian *Ich* of the first Topography, to the more formalized instance of ‘the ego’ of the second topography. However, this is not a very accurate formulation. First of all the term ‘self’ is itself very imprecise and has a relation with the changing subject of discourse, the shifter of the sentence, ‘I’, underpinning the ego’s imaginary identifications. Another more recent view is that Freud, in that work, introduced the imaginary status of the ego, but, as the concept of ‘imaginary’ is not in Freud, the theory of narcissism led to all sorts of misunderstandings. Lacan’s register of the imaginary throws a different light to Freud’s formulations in ‘On Narcissism’, and leads us to clearly differentiate between the imaginary *Idealich*, and the symbolic *Ichideal*.<sup>30</sup>

The term of narcissism existed already. For Havelock Ellis, for example, in his ‘Study in the Psychology of Sex’ (1897), it was ‘a psychological attitude’ and/or a perversion. As a libidinal quantity it was ‘allocated’ to neurotics, homosexuals, and many other people. ‘In that sense’, as Freud says, ‘it is not a perversion but the libidinal complement to the egoism

<sup>30</sup> Lacan signaled the lack of the term in Freud. He inserted the mirror stage (1949) as the imaginary constitution of ego (*moi*), included within the symbolic structure of language. In order to show the tripartite structure of the subject, Lacan used initially diagrams and graphs, and later topological surfaces. His first diagrams were topological too, as he explained, schema *L* (the Z shaped schema in Seminar Book II, 1954-55) and schema *R* (which first appeared in *On a Question Prior to Any Possible Treatment of Psychosis* (*Ecrits*, 1966, Fink trans. 2006). Another of those topological diagrams was his *Graph of Desire* (1957-1959).

of the drive of self-preservation', hence belongs to every living being. It has a place in normal sexual behaviour, as well as in pathological structures.

In his introduction, Freud underlines the extended presence of narcissism, and how, in the psychoanalytic treatment, it can become a limit in the susceptibility to influence the neurotics. Narcissism explained withdrawal in psychosis and in order to distinguish it from the same phenomenon in neurosis, Freud differentiated between a primary, normal narcissism and a secondary narcissism in psychosis: 'Patients of this kind whom I have proposed to term *paraphrenics*, display two fundamental characteristics, megalomania and diversion of their interest from the external world – from people and things.'<sup>31</sup>

It was to answer Jung who had argued that Freud's libido theory came to grief in the study of President Schreber's psychosis, that Freud rethinks his libido theory with the intermediate stage of narcissism, and the new form of the ego lending itself to the libidinal investment of narcissism, that is ego-libido, and with the transition from ego-libido to object-libido which fails in psychosis. Ego libido is nothing other than the libidinal side of the drives of self-preservation ( *Ichinteresse*), he said, which are maintained separately.

Contrary to the neurotic, the paraphrenic:

'... seems really to have withdrawn his libido from people and things in the external world without replacing them by others in fantasy. When he *does* so replace them, the process seems to be a secondary one and to be part of an attempt to recovery, designed to lead the libido back to objects'.<sup>32</sup>

---

<sup>31</sup> Freud, S., (1914c), S.E. **14**, 74. Freud used the term *paraphrenia* as more accurate for the description of *schizophrenia* (Bleuler's term), or *dementia praecox* (Kraepelin's term). He also argued that narcissism makes the *paraphrenics* inaccessible to psychoanalytic treatment.

<sup>32</sup> Ibid. 75.

Thus the destinies of libidinal cathexis follow two distinct paths. There is a successful transition to external objects, which, in neurosis, retreats to objects in fantasy. But, in paraphrenics: ‘the libido that has been withdrawn from the external world has been directed to the ego and thus gives rise to an attitude which may be called narcissism’. This, as Freud explains, is secondary narcissism, ‘superimposed upon a primary one’.<sup>33</sup>

According to Freud himself, his theory of narcissism derived from the clinical practice, especially of the transference neuroses. He was also helped by the observation of the psychical manifestations of primitive peoples and children (for example, the omnipotence of thoughts, or the magic of words). Thus, he charts the libidinal dialectics as a sort of pulsation between ego-libido and object-libido, the ego sending its pseudopodia out to external objects and drawing them back (as an amoeba), or the ego and the external object resembling communicating vessels in the love-hate dialectics. As he says, being in love is the highest level of object- libido. With the *paraphrenics* and the *paranoics*, on the other hand, withdrawal of libido to the ego is complete and inaugurates what is known as the ‘end of the world’ feeling.<sup>34</sup>

Freud addresses two questions: 1) what is the relation of narcissism to auto-erotism, which is the earliest stage of libido (initially he had not distinguished them). 2) If we grant the ego with an original libidinal cathexis (primary narcissism), why to make a distinction

---

<sup>33</sup> Lacan’s commentary of Freud’s ‘On Narcissism’ in his Seminar *Freud’s Papers on Technique*, Book I, 1953-1954 (Miller, J.A., ed. John Forrester transl., Cambridge University Press 1988, especially Chapters IX, X, XI: *on Narcissism, on the two Narcissisms, Ego-ideal and Ideal ego*, op. cit. 107-142).

<sup>34</sup> In connection with the ‘end of the world’ feeling, Freud refers to his ‘Psychoanalytical Remarks’ of the Schreber Case. (Freud, S., 1911c, S.E. 12, Section III, esp. 74-75).

between *ego libido* and *Ichinteresse* (drives of self-preservation), and furthermore, why to make another distinction between ego-libido and object-libido?

The first question concerns the theory of libido. Wouldn't it be easier to keep libido as an original psychical energy, as Jung did, which only becomes sexual when it invests an object? But Freud wanted to keep libido as 'sexual' drive. Narcissism is a libidinal, sexual investment of the ego, which as 'a unity' cannot exist in the individual form from the start. And the difference with the auto-erotic drives is that the latter are there from the start but they are not a unity and they find satisfaction in parts of the body; so there must be something added to auto-erotism, a new psychical action - to bring about the ego as a narcissistic object.<sup>35</sup>

The second question – as to why the distinction of two or even four sets of drives – presents us with more problems. Here Freud compares psychoanalysis to the science of physics, the basic concepts of which, such as matter, centres of force and attraction are still debatable and disputed. While a speculative theory will look for 'logically unassailable foundations', modern empirical science 'will gladly content itself with nebulous, scarcely imaginable basic concepts, which it hopes to apprehend more clearly'<sup>36</sup> with the help of observation. These concepts are not the bottom but the top of the whole structure and can be replaced according to experience from the clinic of neurotics and psychotics.

---

<sup>35</sup> According to Lacan Freud's idea - the ego has to be developed' through 'a new psychical action' - 'confirms the usefulness of his [my] conception of the mirror stage'; *Freud's Papers on Technique*, Seminar Book I, (1953-1954), session 17 March 1954, 115.

<sup>36</sup> Freud, S., (1914c), On Narcissism, an Introduction, op. cit., 78.

Therefore a differentiation between ‘a libido which is proper to the ego’ and an object-libido ‘is an unavoidable corollary to an original hypothesis which distinguished between sexual drives and ego-drives.’<sup>37</sup> The common distinction between *hunger* (drives of self-preservation) and *love* (sexual drives) works in our favour, as Freud says. Second, there is a biological argument, the individual’s ‘twofold existence’: on the one hand man serves his own sexual purposes (*autoerotic and narcissitic*) and, on the other hand, he is a link in the biological chain of reproduction of the species with, in return, ‘a bonus of pleasure’ (sexual satisfaction); he is ‘the mortal vehicle of a (possibly) immortal substance.’<sup>38</sup> What is interesting here is that Freud, admitting the two arguments, the psychological and the biological, uses only the psychological hypothesis as serviceable to psychoanalysis, even if one day the ‘chemical substances and processes’ could take over the whole theory of human sexuality. The biological argument is considered separately and almost, we could say, a part of the ‘real’. Paraphrenia, paranoia, the study of organic disease, hypochondria and the erotic life of the sexes, are the fields of application of Freud’s theory of narcissism.

The question: why do we ever abandon ‘the initial narcissistic position’ is answered by Freud within the frame of the unpleasure principle. The damming-up of libido in the ego can cause excess-unpleasure and serious illness while object-libido, that is love, can cure. Freud reminds us of Heine’s ‘VII Song of Creation’ (*Schöpfungslieder VII*), where God is

---

<sup>37</sup> Ibid.

<sup>38</sup> Freud explains why he objected to Bleuler’s term ‘schizophrenia’: ‘. . . the name appears appropriate only so long as we forget its literal meaning.’ It is based on a characteristic which does not belong exclusively to that disease. (Freud, S., 1911c, S.E. 12, Part III, 75). In the same work, we find a paragraph which was the basis of Jung’s criticisms: ‘the paranoid’s altered relation to the world is to be explained entirely or in the main by the loss of his libidinal interest’.

imagined as saying: ‘Illness was no doubt the final cause of the whole urge to create. By creating I could recover; by creating, I became healthy’.<sup>39</sup>

Mastering an excess amount of libido is an issue for the unpleasure principle, which still regulates the psychical mechanism. An introversion of the libido to unreal, fantasy objects and the ensuing damming-up can be treated in neurosis by the working over of anxiety into symptoms, such as conversions, phobias, reaction-formations. In paraphrenics, although ‘megalomania allows of a similar internal working- over of libido which has returned to the ego’,<sup>40</sup> when megalomania fails, ‘hypochondria’ (psychotic anxiety around the vital organs) replaces it. There can be, however, a new working- over, a restoration of libido-cathexis to external objects in psychosis, a reconstruction of the external world which is a form of recovery. We can think here of the systematization of delusion.

#### **D. Love and the dialectics of ego ideal/ideal ego**

Freud investigates ‘the erotic life of human beings’, the different ways which men and women have to fall in love, as another area where we can learn about narcissism: ‘. . . the first, autoerotic sexual satisfactions are experienced in connection with vital functions which serve the purpose of self-preservation’.<sup>41</sup> Only later the sexual drives become independent of the ego drives. But, their original attachment plays a role in the choice of object. Here is the case for the *anaclitic* or attachment type of love (*Anlehnungstypus*). The person or persons which initially took care of the child’s vital needs, his nourishment for

---

<sup>39</sup> Freud, S., (1914c), S.E. **14**, 85.

<sup>40</sup> Ibid., 86.

<sup>41</sup> Ibid., 87.

example (mother, nurse) become his first sexual objects. To this Freud adds the narcissistic type.

So 1) according to the narcissistic type of love man chooses:

- (a) What he himself is (i.e. himself)
- (b) What he himself was
- (c) What he himself would have liked to be
- (d) Someone who was once part of himself

2. According to the anaclitic type he chooses

- (a) the woman who feeds him,
- (b) the man who protects him, and other substitutes<sup>42</sup>

The possibility to add to the latter a case such as (c) of the first type, will be discussed by Freud in relation to the dialectics of ego ideal/ ideal ego.

Freud does not hesitate to say that ‘complete object-love of the attachment type is properly speaking characteristic of the male’, where the original narcissism is transferred to the sexual object: ‘This sexual overvaluation is the origin of the peculiar state of being in love, a state suggestive of a neurotic compulsion . . . an impoverishment of the ego . . . in favour

---

<sup>42</sup> Ibid., 90.

of the love-object'.<sup>43</sup> For the feminine subject Freud finds an intensification of the original narcissism, in puberty: 'Women, especially if they grow up with good looks, develop a certain self-contentment . . . strictly speaking it is only themselves that such women love with an intensity comparable to that of the man's love for them.'<sup>44</sup>

But, as Freud insists, he does not divide human beings 'into two sharply differentiated groups' according to their object-choice. Both kinds are 'open to each individual'. Freud postulates 'a primary narcissism in everyone' and adds that 'a human being has originally two sexual objects – himself and the woman who nurses him'.<sup>45</sup>

Among the disturbances to which the child's original narcissism is exposed Freud singles out as 'the most significant' the 'castration complex' found in the epoch when the ego drives and the sexual drives appear mingled as narcissistic interests. What Adler called 'the masculine protest' (1910) in men and women, was the social aspect of the castration complex as deriving from the ego- interests. But psychoanalysis, according to Freud, is interested in the sexual aspect of the ego's drives and, cannot agree with Adler at that stage to take the castration complex as the sole pathogenic cause of neurosis.<sup>46</sup>

---

<sup>43</sup> Ibid., 88.

<sup>44</sup> Ibid., 89.

<sup>45</sup> Ibid.

<sup>46</sup> Ibid., 92. A theory of neurosis caused by the *castration complex* was not compatible with Freud's first theory of anxiety as a non-repressed sexual excitation which cannot be represented in the psyche. But, in 'Inhibitions, Symptoms, and Anxiety' (1926d), Freud developed a second theory of anxiety, in which the castration complex causes psychical *anxiety* followed by *repression* and not the other way round. This is why we can consider that work as the real Third Topography of Freud.



Freud finds, instead, the cause of the disappearance of infantile narcissism in ‘the psychology of repression’. He now asserts that ‘repression proceeds from the ego’, and indeed from ‘the self-respect of the ego’. It is in this way that infantile narcissism is abandoned: ‘One man has set up an ideal in himself by which he measures his actual ego, while the other has formed no such ideal. For the ego the formation of an ideal would be the conditioning factor of repression’.<sup>47</sup>

The ideal ego is the heir of the original narcissism in Freud’s theory. It has been formed following the ego’s ‘cultural and ethical ideas’, which the ego is measured by, in other words it is based on the ego ideal. Hence the two terms cannot be interchangeable but in a dialectical relation:

‘One man has set up an *ideal* in himself by which he measures his actual ego . . . This ideal is now the target of self-love which was enjoyed in childhood by the actual ego (*das wirkliche Ich*) The subject’s narcissism makes its appearance displaced on to this new ideal ego . . . man is not willing to forgo the narcissistic perfection of his childhood . . . he seeks to recover it in the new form of an ego ideal’.<sup>48</sup>

Freud also argued that narcissism can be transferred to an object of love as sexual overvaluation. This process is also called idealization. *Idealization* ‘concerns the object’, thus it is possible in both ego-libido (the ego becomes an object) and object libido.<sup>49</sup> As having to do with the object, the process of idealization is different from the process of

---

<sup>47</sup> Ibid., 93-94.

<sup>48</sup> In ‘Group Psychology and the Analysis of the Ego’ (1921c), Freud drew the diagram of the transition from the external object to the ego ideal and to the ideal ego (S.E. **18**, 116); Lacan’s Chapters IX, X, XI in Seminar Book I, *Freud’s Papers on Technique* (1953-54). For him ‘the first narcissism is situated at the level of the real image’ of the body in his *Optical Schema*, the second narcissism at the level of the virtual image, as ‘narcissistic identification . . . identification to the other’ (op. cit., 24 March 1954).

<sup>49</sup> Freud does not develop here the processes of identification involved in the formation of the ideal. He will do that later in ‘*Group Psychology and the Analysis of the Ego*’ (1921c). Identification in Lacan will be developed in the second part of this thesis.

sublimation which has to do with the drive, as Freud underlines. The formation of an ideal increases the demands of the ego and favours repression. Sublimation, on the other hand, is a way out of repression, where the ego's demands 'can be satisfied *without* involving repression.'<sup>50</sup>

Freud has not yet made the difference of the ego ideal from its effects on narcissism(ideal ego), but the premises are here to be developed. There is almost a need for '... a special psychological agency which performs the task of seeing that narcissistic satisfaction from the ego ideal is ensured and which, with this end in view, constantly watches the actual ego and measures it by that ideal'.<sup>51</sup> He gives as an example the 'delusion of being watched' in paranoid psychosis.

This agency exists in normal life, too, as he says, it is what we call conscience or the critical function comparable to the dream-censor. Out of this agency Freud will develop the superego, first in *The Ego and the Id* (1923b) and slowly will replace it: 'For what prompted the subject to form an ego ideal on whose behalf his conscience acts as a watchman, arose from the critical influence of his parents (conveyed to him by the medium of the voice) to whom were added ... his fellow-men and public opinion.'<sup>52</sup>

Freud argues that 'large amounts of libido of an essentially homosexual kind are drawn into the formation of the narcissistic ego ideal and find outlet and satisfaction in maintaining

---

<sup>50</sup> Freud, S. (1914c), S.E. **14**, 95

<sup>51</sup> Ibid.

<sup>52</sup> Ibid., 96

it.<sup>53</sup> To lift the equivocation of the ‘narcissistic ego ideal’, we could reformulate this as: ‘The ego ideal satisfies the original narcissism in the form of the ideal ego’. Freud who considered repressed homosexuality as a cause of paranoia (secondary narcissism), can say that an amount of homosexuality (and self-love) does indeed contribute to the formation of the ideal ego, but not of the ego ideal. To achieve the complete detachment of the ego ideal from narcissism, Freud needs first to distinguish a ‘repression which develops out of a prohibition or obstacle which came from without’, in the form of the superego:

‘The institution of conscience was at bottom an embodiment, first of parental criticism and subsequently of that of society - a process which is repeated in what takes place when a tendency towards repression develops out of a prohibition or obstacle that came in the first instance from without. The voices as well as the undefined multitude are brought into the foreground again by the disease.’<sup>54</sup>

As Freud notes, the critically observing agency may play a role in other areas too, for example in certain states between sleeping and awakening, which Silberer called ‘functional phenomena’.<sup>55</sup>

A discussion about self-regard ( *Selbstgefühl*) brings us back to the ‘size of the ego’, dependent on its narcissistic investment (ideal ego). In the neurotic it is diminished, in the

---

<sup>53</sup> Ibid.

<sup>54</sup> Ibid. Thus the superego is playing an important role in psychosis, in the persecutory feelings of the paranoics, and in the paraphrenics’ self-criticism which is at bottom self-observation. Self-conscience is thus ‘placed in the service of internal research and philosophical introspection which we often find in them, as well as in other people, of course’, as Freud says.

<sup>55</sup> Herbert Silberer had published a paper on hallucinatory phenomena in *Jb. psychoanal. psychopath. Forsch.*, **1**, 513, in 1909, and another in 1912, ‘On the symbolism of awakening and of the threshold to sleep’ (op.cit., S.E. **3**, 621). As Freud noticed, both in ‘On Narcissism’ (1914c, S E. **14**, 97) and in a longer passage added in 1914 in ‘The Interpretation of Dreams’ (S.E. **5**, 503-506), Silberer’s developments show that in states between sleeping and awakening not only we can directly observe the translation of our thoughts into hallucinations (‘material phenomena’), but also the actual state in which we, as the dreamer, are in the manner of paranoid delusions, for example: now he is sleeping etc (the so-called ‘functional phenomena’). Thus the censor of the dream does not only represent ‘the repressive trends of the ego’ by transforming thoughts into visual images, but also becomes part of the structure of the ego both as ‘ego ideal’ and as the ‘dynamic utterances of conscience’.

paraphrenic it is increased. In love relations, not being loved lowers self-regard, being loved heightens it. Freud concludes: 'The aim and the satisfaction of a narcissistic object-choice is to be loved'. Love and the ideal are inextricably linked. But love, 'libidinal object-cathexis' does not necessarily raise 'self-regard' (nor heightens the ideal ego). Dependence on the love object lowers that feeling. 'A person in love is humble . . . he has forfeited part of his narcissism and it can only be replaced by being loved'.<sup>56</sup>

As self-regard is an expression of 'the size of the ego', therefore depends on narcissistic libido, an opposition between omnipotence and impotence is the expression of the way narcissistic libido is distributed, either to the object or to oneself. The inability to love, due to mental or physical disorder, Freud says, lowers self-regard and has as a consequence a severe depletion in the ego. Here we have to look for the feelings of inferiority, recognized by Adler (1907), as Freud points out. Freud summarises his points and concludes with the following remarks:

'The development of the ego consists in a departure from primary narcissism, and gives rise to a vigorous attempt to recover that state. This departure is brought about by means of the displacement of libido on to an ego ideal imposed from without; and satisfaction is brought about from fulfilling this ideal.'<sup>57</sup>

In other words, the ego becomes impoverished both by the libidinal object cathexis (love) and by the ego ideal, while it becomes enriched by being loved, and by fulfilling the ideal ego.

---

<sup>56</sup> Freud, S., 1914c, S.E. 14, 98.

<sup>57</sup> Ibid., 100.

The ego ideal leads Freud to the ‘understanding of group psychology . . . it has a social side’, too. It can be the ideal of a class, a family, a nation. It binds a considerable amount not only of one’s narcissistic libido but also of homosexual libido. Otherwise there is a return back to the ego:

‘The want of satisfaction which arises from the non-fulfilment of this ideal liberates homosexual libido and this is transformed into a sense of guilt (social anxiety). Originally. . . guilt was a fear of punishment by the parents, or, more correctly, the fear of losing their love . . . The frequent causation of paranoia by an injury to the ego, by a frustration of satisfaction within the sphere of the ego ideal, is thus made more tangible, as is the convergence of ideal-formation and sublimation in the ego ideal as well as the involution of sublimations and the possible transformation of ideals in paraphrenic disorders.’<sup>58</sup>

So, a lot of complex new ideas are formulated succinctly at the end of this text, as Freud systematizes his thoughts around the ego ideal, the ideal ego, the sexual ideal: If an ideal is not formed ‘the sexual trend . . . makes its appearance . . . in the form of perversion’. Being in love can also reinstate perversions, as it removes repression.<sup>59</sup>

### **E. The importance of Drives**

Freud’s metapsychological paper on ‘Drives and Their Vicissitudes’ (1915c) follows in the aftermath of the introduction of narcissism. It is now the time for the development of the concept of the drive after the ego and its narcissistic investment (ego libido) became the other pole opposite the sexual libido. The vicissitudes of the sexual drives now gain a closer look. But first, of particular interest to us, are the nuances and refinements of the ego (*Ich*), which is here defined as an original reality ego ( *anfängliches real Ich*). ‘Drives and

---

<sup>58</sup> Ibid., 102.

<sup>59</sup> Ibid.

their Vicissitudes' directs us towards a different look at the original *Ich* than the one described in 'Formulations' (1911b) as an 'original auto-erotic ego'. What is emphasized now is how *real Ich*, the original psychical mechanism, is split by the interest of the external object, which the sexual drives bring with them.<sup>60</sup>

For ten years or so, since 'The Interpretation of Dreams' (1900a), Freud had not returned to the grand theoretical issues of the first period. But, during the war, he wrote or at least drafted twelve theoretical papers to be published in one book as 'Preliminary to a Metapsychology' (*Zur Vorbereitung einer Metapsychologie*). But the last seven were never published and, according to Ernest Jones, were definitively lost.<sup>61</sup> Introducing 'Drives and their Vicissitudes' (1915c), Strachey reminds us that Freud had earlier referred indirectly to the need for nourishment as determining the child's first choice of a sexual object,<sup>62</sup> but the concept appears suddenly in Freud's paper 'The Psychoanalytic View of Psychogenic Disturbance of Vision' (1910i).<sup>63</sup> 'Sexual drives' are now distinguished from the 'ego drives', and the latter have to do with the repressive function of the ego. Freud's theory of a dualism of the drives saw its first clinical application in his 'Psychoanalytic Notes on an

---

<sup>60</sup> 'Some of the sexual instincts [drives] are, as we know, capable of this autoerotic satisfaction and so are adapted of being the vehicle for the development under the dominance of the pleasure principle [from the original reality-ego into the pleasure-ego] which we are about to describe.' (Freud, S., 1915c, S.E. **14**, 134, n. 2)

<sup>61</sup> We learn from Ilse Grubrich-Simitis that she discovered one of the lost metapsychological works in a manuscript, while researching the correspondence between Freud and Ferenczi, in 1983 in London. The original, established by her, was published in German, and then in a bilingual edition translated by P. Lacoste, which appeared in 1985, in Paris as *Vue d'ensemble des névroses du transfert (Übersicht der Übertragungsnerven)*.

<sup>62</sup> This was already found in the first edition of the 'Three Essays' (1905d, S.E. **7**, 222) and in a footnote [ibid., footnote 1], but added in 1915, that is after the paper 'On Narcissism' (1914c). It was in the 'attachment' type of love that sexual and ego drives mingled.

<sup>63</sup> The drives which 'subserve sexuality, the attainment of sexual pleasure' enter into opposition with 'those other drives 'which have as their aim the self-preservation of the individual', the ego drives (*Ichtriebe*). 'The ego feels threatened by the claims of the sexual drives and fends them off by repressions' (Freud, S., S.E. **11**, 214 and 215).

Autobiographical Account of a Case of Paranoia' (1911c).<sup>64</sup> However, the insertion of narcissism in 1914, complicated things, as the ego became itself a libidinal object. Freud introduced a second distinction there, as we know, between 'ego libido' (*Ich Libido*) and 'object libido' (*Objekt Libido*). Things became even more complicated, as the status of the 'ego interests' (*Ichinteresse*), the ego drives themselves becomes ambiguous. They can be either libidinal, and coincide with the ego interests in general or be in opposition to them.<sup>65</sup>

At the start of 'Drives and their Vicissitudes' (1915c) Freud talked about the nature of scientific concepts. Psychoanalysis, like any other science, he argued, uses *Grundbegriffe*, basic scientific concepts, which are necessary 'abstractions' or 'conventions', only becoming clearly defined after a certain number of observations have been carefully studied. 'Drive' (*Trieb*) is 'a conventional basic concept of this kind'.<sup>66</sup>

The term appeared first in Part I [10] of the 'Project' (1895): '. . . in the interior of the system there arises the impulsion (*Antrieb*) which sustains all psychical activity. We know this power as the will, the derivative of the instincts (*Triebe*).'<sup>67</sup>

---

<sup>64</sup> Freud, S., (1911c), S.E. **12**, 70, n. 2: 'He [the paranoic] has perhaps withdrawn from it (the external world) not only the libidinal cathexis, but his interest in general- that is the cathexes that proceed from his ego as well'. This is what is described in the 'end of the world' feeling in paranoia.

<sup>65</sup> The nature of the self-preservative drives was still a bit of a mystery for Freud during that period, as Strachey underlines. But, in *Beyond the Pleasure Principle* (1920g), Freud remarks that 'libido which was lodged in the ego' and 'described as 'narcissistic', 'had necessarily to be identified with the self-preservative drives'. Thus, the original opposition between the ego-drives and sexual drives seemed inadequate and Freud's dualism of the drives could be in trouble. But, he proposed instead a new duality. He suggested first that their difference was not qualitative, as previously thought, but 'topographical' (Freud, S., (1920g), S.E. **18**, 52). Second, dualism was transposed to the opposition between the life and death drives, *Eros* and *Thanatos*.

<sup>66</sup> Freud, S., (1915c), S. E. **14**, 117.

<sup>67</sup> Freud, S., (1950a[1895]), S.E. **1**, 317. Strachey preferred to translate the term as 'instinct' and not 'drive' (*Editor's Note*, S.E. **14**, 111), but the term has gained ground since Lacan insisted on the use of its French equivalent: *la pulsion*.

There are in Freud's work three definitions, substantially similar, for the concept of the drive:

- 1) 'We regard 'instinct' [drive] as being the concept on the frontier-line between the somatic and the mental, and see in it the psychical representative of organic forces' <sup>68</sup>
- 2) 'By an "instinct" [drive] is provisionally to be understood the psychical representative of an endosomatic, continuously flowing source of stimulation as contrasted with a "stimulus" which is set up by *single* excitations coming from *without*. The concept of instinct is thus one of those lying on the frontier between the mental and the physical.' <sup>69</sup>
- 3) '... an instinct appears to us as a concept on the frontier between the mental and the somatic, as the psychical representative of the stimuli originating from within the organism and reaching the mind, as a measure of the demand made upon the mind for work in consequence of its connection with the body.' <sup>70</sup>

The notion of 'frontier- concept' and of 'representative' is found in all three. The drive was presented as the psychical representative of an endo-somatic excitation (flowing from the *erotogenic zone* ), and as 'an excitation ( *Reiz*) for the psychical.' Freud makes a differentiation between drive- excitation and any other physiological stimulus. <sup>71</sup>

But, then Freud specified that only an ideational representative represented the drive's excitation in the unconscious. This he called: *Triebrepräsenz*: 'Repression in fact interferes only with the relation of the instinctual [drive] representative to one psychical system, namely, to that of the conscious.' <sup>72</sup>

<sup>68</sup> Freud S., (1911c) 'Psychoanalytic Notes on an Autobiographical Account of a Case of Paranoia', S.E. **12**, 74.

<sup>69</sup> The whole paragraph was added in 1915. (Freud, S., 1905d, S.E. **7**, 168).

<sup>70</sup> Freud, S., 1915c, S. E. **14**, 121-122.

<sup>71</sup> Freud, S., (1915c), S.E. **14**, 118. We remember that the ' *endogene Reizen*' in the 'Project' were thought (Strachey), as 'the precursors of the drives'. Here Freud differentiates *Triebreiz* or *Triebregung* from a simple physiological stimulus which originates in the outside world. The drive's excitation comes from within the organism. It 'never operates as a force giving a *momentary* impact, but always a *constant* one (*Konstante Kraft*).' A better term for it, as Freud suggests, is need (*Bedürfniss*). Need or better, demand; Freud, S., G.W. **X**, 211.

<sup>72</sup> Freud, S., (1915d), S.E. **14**, 149.



In ‘The Unconscious’ (1915e), Freud said more explicitly:

‘An “instinct” [drive] can never become an object of consciousness -only the idea that represents the “instinct” [drive] can. Even in the unconscious, moreover an “instinct” [drive] cannot be represented otherwise than by an idea.’<sup>73</sup>

And, continued:

‘When we nevertheless speak of an unconscious instinctual [drive] impulse (*Triebregung*) or of a repressed instinctual [drive] impulse . . . we can only mean, an instinctual [drive] impulse the ideational representative of which (*Vorstellungsrepräsentanz*) is unconscious . . .’<sup>74</sup>

There was some apparent confusion of the terms there, which led the French authors of ‘The Language of Psychoanalysis’ (Laplanche and Pontalis, 1973) to consider the difference between the instinctual[drive] representative ( *Triebrepräsenz*) and the ideational representative ( *Vorstellungsrepräsentanz*) as non-essential. In both they find an element of representation, a representative to which the drive, which is basically a somatic excitation, attaches itself. For them, a representation or group of representations ‘fixes the drive’ as its psychical representative. However, they find a difference between them in the *signs* or *memory traces* of the object itself. They are ‘essentially visual’ as far as the object is concerned (See Freud’s ‘Thing-representations’ *Sachvorstellungen*), as for the unconscious ideas and conscious memories, they are essentially auditory (see Freud’s ‘Word-representations,’ *Wortvorstellungen*).<sup>75</sup>

---

<sup>73</sup> Freud, S., (1915e), S.E. **14**, 177.

<sup>74</sup> Ibid.

<sup>75</sup> Freud moved away from the idea that the drive was a particular sort of somatic excitation (endosomatic) involving an *erotogenic zone*. It was a psychical excitation (paragraph added in 1915 in ‘The Three Essays’, cf.: this chapter, this thesis p. 123, note 169). The drive was the psychical representative of the erotic excitation. He presented both elements, the quantitative( *affect*) and the idea ( *representation*) as psychical representatives of the drive in ‘The Unconscious’(1915d), only to return later to his earlier idea about their difference (In ‘Outline of Psychoanalysis’, 1940a [1938]). In his Seminar ‘ *Desire and its Interpretation*’, (26 November 1958, unpublished), Lacan singled out Freud’s *Triebregung* [the drive excitation] as an ‘objective concept’, ‘a fragment of reality’. In his Seminar ‘The Four Fundamental Concepts of Psychoanalysis (Book

Freud further disassembled the *Vorstellungs- or Triebsrepräsentanzen* in two parts, the idea and another quantitative element besides ‘the quota of psychical energy’ which also represents the drive, but undergoes vicissitudes different than the drive.<sup>76</sup> He called that other element a ‘quota of affect’ (*Affektbetrag*). The drive can either be ‘altogether suppressed . . . or it appears as an affect . . . or it is changed into anxiety.’<sup>77</sup> However, the element ‘affect’ has no proper status in the unconscious. As Freud states in his paper ‘The Unconscious’ (1915e), we are aware of feelings, emotions and affects, but ‘the possibility of the attribute of unconsciousness would be completely excluded as far as emotions, feelings and affects are concerned’.<sup>78</sup>

Concepts have important clinical and technical repercussions, even if they appear to be too abstract. This is the case for the theoretical debate about the drive. Is the drive pure instinctual, somatic force, or is it something entirely psychical, and what does Freud mean with the notion of a ‘representative of the drive’, a *Triebrepräsenz* and/or a *Vorstellungsrepräsentanz*?<sup>79</sup>

---

XI, 10 June 1964) he found his S 2s, the signifiers of unconscious meanings, in Freud’s *Vorstellungsrepräsentanzen* which he translated as ‘the representatives of the representation’ insisting, unlike Laplanche and Pontalis, on the objective meaning of the genitive (They translated the term as *représentant-representation*).

<sup>76</sup> Freud S., (1915d), S.E. **14**, 152. For the term *Affektbetrag* see Strachey’s note 2, *ibid*. He dates it back to the Breuer period. There is a whole discussion about the status of affects in Part III of the paper ‘The Unconscious’ (1915e). ‘Strictly speaking . . . there are no unconscious affects as there are unconscious ideas’ (*op. cit.*, S.E. **14**, 178).

<sup>77</sup> Freud S., 1915d, S.E. **14**, 153.

<sup>78</sup> Freud S., 1915e, S.E. **14**, 177.

<sup>79</sup> For Lacan, under the representative of the drive, there lies the subject of the Unconscious, the subject of desire. It is not properly a representation, a subject cannot be represented, and further cannot be represented other than by a signifier, S1, for another signifier S2 as he will later say. The subject lies under (*subjicere*) the signifying chain. He said that in Seminar *Desire and its Interpretation* (26 November 1958). In Seminar *The Four Fundamental Concepts of Psychoanalysis* (1964) he found the ‘first signifying coupling that enables us

In the beginning of 'Drives and their Vicissitudes' (1915c), besides the importance of those conventions called 'basic concepts', Freud also refers to the use of a number of 'complicated postulates' in dealing with psychological phenomena. The most important of all and 'of a biological nature' runs as follows: 'the nervous system is an apparatus which has the function of getting rid of the stimuli that reach it or of reducing them to the lowest possible level'. This was the old principle of constancy or homeostasis. But the intervention of drives created difficulties in that simple, almost physiological pattern. As a 'constant force from within the organism', it cannot be dealt with by the mechanism of homeostasis.<sup>80</sup> '[The Drives] make far higher demands on the nervous system and cause it to undertake involved and interconnected activities by which the external world is so changed as to afford satisfaction to the internal source of stimulation'.<sup>81</sup>

Freud proposes four coordinates of the drive: The pressure ( *Drang*), the aim ( *Ziel*), the object ( *Objekt*) and the source ( *Quelle*). The pressure is linked by Freud to the motor factor, 'it is the amount of force, the measure of the demand for work'. The aim is satisfaction, as the drive or better the drive's excitation ( *Triebreiz, Triebregung*) is not dissimilar from a 'need' ( *Bedürfnis*). In that respect, different paths may be taken, and even when a drive is inhibited as to its aim, as in sublimation, it is legitimate to think that there is some 'partial satisfaction'. As for the object, it is 'most variable', and it is not 'originally connected' with

---

to conceive that the subject appears first in the Other . . .' in the term *Vorstellungsrepräsentanz*. He called that 'the original mechanisms of alienation.'

<sup>80</sup> Freud S., (1915c), S.E. 14, 120. If the nervous system's purpose is to *master stimuli*, one thing it cannot master are the drive stimuli. It is true that Freud places these stimuli within the organism first and making higher demands on it.

<sup>81</sup> Ibid., 120. They may themselves be, in part, 'the precipitates of the effects of external stimulation', as Freud adds. The quantity they are cathected with leaves a remainder, something which Freud noticed.

the drive, but only assigned to it; it is not only an external object, but it could also be ‘the subject’s own body’. It can change many times over, or it can be the same, as the drive becomes ‘fixated’ to an object. It ‘can serve several drives simultaneously’ (what Adler termed ‘confluence of drives’ – *Triebverschränkung* – in 1908). The sources are somatic, but as Freud underlines, ‘in mental life we know them only by their aims’. Freud also raises the question if there can be different qualities in the drives, a hypothesis which he discards, only admitting the quantitative character of the drive. Their differences are due to their different somatic sources. He reminds us his basic division between two groups, the ego - or self-preservation drives and the sexual drives.<sup>82</sup>

The libidinal sexual drives were originally attached to the ego- drives and chose their object guided by the latter. This is something Freud first aired in his paper ‘On Narcissism’, where he talked about the anaclitic form of love.<sup>83</sup> Now he talks about the vicissitudes of the drives after they have been detached from the ego-drives: These vicissitudes are: a) Reversal of the drive into its opposite, from activity to passivity, or a reversal of content, as in love and hate b) Turning round upon the subject’s own self as in sadism versus masochism and scopophilia versus exhibitionism c) Repression d) Sublimation. These

---

<sup>82</sup> Freud, S., (1915c), S.E. **14**, 124. This is a reformulation of the old conflict between ego and sexuality in *The Three Essays*. The sexual drive(s) were therefore part or component drives seeking ‘organ pleasure’. As Freud underlines here ‘only when synthesis is achieved ... they enter the service of the reproductive function. They, then, become... recognizable as sexual drives. At their first appearance they are attached to the drives of self-preservation’ (ibid. 126). As *Strachey* notes, sexual *Trieb*, did not really make its appearance until the *Three Essays* (1905d) and *Triebregungen* appears as late as 1907 in ‘*Obsessive actions and religious practices*’. But, the representatives of the drives, we may say, they were present in Freud’s earlier works as affective ideas, wishful impulses, sexual affects. In the ‘Project’, ‘endogenous stimuli had their origin in the cells of the body and gave rise to the major necessities of life, hunger, respiration and sexuality’, and where therefore the precursors of the drives.

<sup>83</sup> ‘The sexual drives are at the outset attached to the satisfaction of the ego-drives’, (Freud, S., 1914c, S.E., **14**, 87); Abraham’s paper on ‘The first pregenital stage of the libido’(1916): ‘In the first place the drive is not directed to another object, but is manifested autoerotically’ (in *Selected Papers on Psychoanalysis*, Maresfield reprints, London, first published in 1927.

vicissitudes are referred to as ‘modes of defence against the drives’. After the formulation of a grammar of drives which possess the active, passive and reflective modes, Freud focuses on the change of content of a drive, the only one known being the reversal from love to hate. Loving, actually, admits *not one but three opposites*, as he says: loving and hating, loving and being loved and loving/hating as opposed to indifference. The grammatical construction of the drives allows Freud to formulate three polarities in the structure of our psychical life: 1) Ego ( *Ich*) – non-ego ( *non-Ich*), or Subject ( *Subjekt*)-object ( *Objekt*), external world, 2) Pleasure - Unpleasure, and 3) Active - Passive. We can say here that in Freud too the drives are taken within the structure of language while keeping their relation to the quantitative element of tension/ and or satisfaction.

From ‘the three polarities of our mental life’ we are going to focus on the polarity Subject (*Ich*) and Object (non- *Ich*) which interests our research. We need to bear in mind here that the initial *Ich* (*Ur-Ich*) was vested with interests *Ichinteresse/Ichtriebe*, which were non-sexual, but self-preservative. The original *Ich*'s function was resistance and repression, and its aim was homeostasis. This was the *Ich* in the ‘Project’. But, in the paper ‘On Narcissism’, *Ich* became itself cathected with libido, a narcissistic object of love. Although, in that paper, Freud differentiated between auto-eroticism and narcissism, the line is not drawn absolutely clearly, and here, in his paper on ‘Drives’, the parts of the body involved in the drive are qualified as auto-erotic, narcissistic objects, and narcissism leads to ‘auto-erotic satisfaction’. Hence, passive scopophilia ‘holds fast to the narcissistic object’ It

seems that, both these cases, passive scopophilia and masochism, ‘replace the narcissistic subject, through identification, with another extraneous ego’.<sup>84</sup>

Freud will conclude that: ‘The vicissitudes of the drive being turned round upon “the subject’s own ego” and undergoing reversal from activity to passivity are dependent on the narcissistic organization of the ego and bear the stamp of that phase’.<sup>85</sup>

Here is Freud’s development:

‘Originally, at the very beginning of mental life, the ego is cathected with instincts and is to some extent capable of satisfying them on itself. We call this condition “narcissism” and this way of obtaining satisfaction “auto-erotic”. At this time the external world is not cathected with interest . . . and is indifferent for purposes of satisfaction. During this period therefore the ego-subject coincides with what is pleasurable and the external world with what is indifferent (or possibly unpleasurable, as being a source of stimulation). If for the moment we define loving as the relation of the ego to its sources of pleasure, the situation in which the ego loves itself only and is indifferent to the external world illustrates the first of the opposites which we found to “loving”’.<sup>86</sup>

The first polarity put in place, by Freud, coincides with the antithesis ego—non-ego, subject-object, a differentiation of the ego from the external world-object. There was at first a ‘sound objective criterion’ of which Freud talks a few paragraphs later (indifference for

---

<sup>84</sup> In Lacan’s early developments *Urich* and *Lustich* are one and the same thing. Before the *Ich* there is chaos, reality pure and simple, ‘all the ids, objects, instincts, desires...’ Indeed, the specific domain of the primitive ego, *Urich or Lustich*, is constituted by a splitting, by a differentiation from the external world’ (Lacan, J., *Freud’s Papers on Technique*, Seminar Book I, 24 Feb. 1954, Forrester, 79). Lacan used the optical schema there, in which the vase takes the function of the body- container and the flowers are the objects contained to show the articulation between symbolic and imaginary.

<sup>85</sup> Freud, S., (1915c), S.E. 14, 132. Despite the rightness of that statement, there is something else at stake here, there is first the symbolic dimension, and ‘a real at stake’, according to Lacan.

<sup>86</sup> Ibid., 134. In *The Four Fundamental Concepts of Psychoanalysis*, Seminar Book XI, 10 June 1964, Lacan comments on this paragraph: ‘First there is an *Ich*, an *Ich* defined objectively by the combined functioning of the apparatus of the central nervous system and the condition of homeostasis . . . outside there is merely indifference . . . indifference simply means non-existence. Freud tells us however that the rule of autoeroticism is not the non-existence of objects, but the functioning of objects solely in relation to pleasure. In the zone of indifference a distinction is made between that which brings *Lust* and that which brings *Unlust*, pleasure or displeasure’ (Lacan, J. op. cit., 1981, 240). Lacan proposed an Eulerian topology, for that.

the external world, flight from the stimulus). Then the external world is differentiated in what is pleasurable and taken in, introjected, and what is unpleasurable and expelled outside: the ego-subject coincides with what is pleasurable and the external world with what is indifferent (or possibly unpleasurable):<sup>87</sup>

‘Thus the original “reality-ego” which distinguished internal and external by means of a sound objective criterion, changes into a purified “pleasure ego”. . . For the “pleasure-ego” the external world is divided into a part that is pleasurable, which it has incorporated into itself, and a remainder that is extraneous to it.’<sup>88</sup>

As Freud underlines in a footnote:

‘Some of the sexual instincts are, as we know, capable of this auto-erotic satisfaction’ and so they can become ‘the vehicle for the development, under the dominance of the pleasure principle [from the original reality ego into the pleasure ego].’<sup>89</sup>

Continuous pressure caused by the drives forces the subject/ *Ich* to turn to objects in the external world, as at the same time, the external world is interested in it. It begins to ‘introject’, incorporate (*einverleiben*) the objects that are presented to it on condition that they are sources of pleasure. Purified from excess pleasure or simply unpleasure it expels the remainder (*Rest*), which is rejected as hostile (*feindliche*) and stranger (*fremde*), but which, at the same time, is at the very heart and centre of it.<sup>90</sup>

---

<sup>87</sup> Freud S., op. cit., 135. Lacan finds that in this paper, Freud places love ‘at once at the level of the real, at the level of narcissism, at the level of the pleasure principle in its correlation with the reality principle’ (Lacan, J., op. cit., 1981, 240).

<sup>88</sup> Freud S., op. cit., 136. Lacan comments that while *Ich* is an apparatus tending to a certain homeostasis, *Lust*... is always an object, an object of pleasure, which as such is mirrored in the ego. This mirror-image, this bi-univocal correlate of the object, is here the purified *Lust-Ich*, the *Ich* satisfied with the object via *Lust*.’ (Lacan, J., op. cit., 1981, 241).

<sup>89</sup> Freud, S., (1915c), S.E. 14, 134, note 2. The ‘original reality-ego’, (*Real-Ich*) postulated here by Freud, is not the *Real-Ich* which was developed out of *Lust-Ich* in *Formulations*. It is a hypothetical *Ich*, closer to the nervous apparatus with homeostasis which under certain circumstances, ‘changes into a purified pleasure ego.’

<sup>90</sup> A similar development is to be found in Freud’s paper on ‘Negation’ (1925h), where these issues of the differentiation between the external and the internal, the hostile and foreigner but also identical to the ego, are discussed.

Love and hate present us with a special problem. As Freud indicates, there are problems in fitting love into the scheme of the drives, and although there are ‘intimate relations’ between the feelings of love and hate and sexual life, ‘we are unwilling to see love as a special component drive of sexuality’. In fact he adds that ‘we should prefer to regard loving as the expression of the whole sexual current of feeling’.<sup>91</sup>

Love, like the drives, can turn into its opposite, hate. But we do not know what sexual meaning to attach to it, as Freud says. ‘Being loved’ is another opposite to love (from active to passive mode), clearly narcissistic, as it derives from the narcissistic ‘loving oneself’. ‘Indifference’ is an opposite to both love and hate. So, although love is entering the grammar of the drives, its content does not fit the sexual drives, it remains suspended between real and imaginary, as Lacan said. It rather fits the relation of the ego to its sources of pleasure and unpleasure, to the external world and the objects it introduces:

‘the object is brought to the ego from the external world in the first instance by the drives of self-preservation; and it cannot be denied that hating too characterized the original relation of the ego to the alien external world with the stimuli it introduces. Indifference falls into place as a special case of hate or dislike after having first appeared as their forerunner. At the very beginning the external world, objects and what is hated is identical’.<sup>92</sup>

---

<sup>91</sup> ‘But this idea does not clear up our difficulties’ (Freud, S., 1915c, S.E. **14**, 133).

<sup>92</sup> Ibid., 136. In ‘Negation’ (1925h) Freud wrote: ‘What is bad, what is alien to the ego, and what is external are, to begin with, identical.’ (Freud, S., 1925h, S.E. **19**, 237). Lacan placed Freud’s hostile, indifferent, and alien to the ego object, back in the heart of *Ich*. He called it ‘object a’. It is neither the sexual object, nor the object of love or pleasure.



## F. The unconscious and repression

In 'Formulations on the two Principles of Psychological Activity' (1911b) the gains of pleasure (*Lustgewinn*) were ensured for the ego, thanks to the dominance of the pleasure principle, even when the 'reality principle' took over.<sup>93</sup> But, the continuous presence of unpleasure in the neurotic symptoms, for example, did not answer the question why something that should have only generated pleasure (the satisfaction of a drive impulse) was often felt as unpleasure. We also saw, in 'Drives and their Vicissitudes' (1915c) that, in relation to the pleasure-ego (*Lustich*) which identified only with the objects that brought pleasure, the element unpleasure had to be rejected, expelled. But was this expulsion as effective as it seemed? We saw that, although repression affected the representatives of the drives, satisfaction of the drive impulse was possible under repression. So the effectiveness of repression was itself problematic. There was the need to tackle once again and better these questions of the separation between the systems which had not been answered so far in a satisfactory way. For, although repression was largely identified with the unconscious, it could only happen after the separation between the unconscious and consciousness: '. . . repression is not a defensive mechanism which is present from the very beginning and that it cannot arise until a sharp cleavage has occurred between conscious and unconscious mental activity.'<sup>94</sup> Even if it did not exist, repression, should have to be invented in order to explain *a posteriori* a host of clinical phenomena. Symptoms, for example, are the manifestation of a return of 'the repressed'. Freud addressed the question of resistances,

---

<sup>93</sup> 'Just as the pleasure-ego (*Lustich*) can do nothing but wish, work for a yield of pleasure (*Lustgewinn*) and avoid unpleasure, so the reality-ego (*Realich*) need do nothing but strive for what is useful and guard itself against damage. Actually the substitution of the reality principle for the pleasure principle implies no deposing of the pleasure principle, but only a safeguarding of it' (Freud, S., 1911b, S.E. 12, 223).

<sup>94</sup> Freud, S., (1915d), S.E. 14, 147.

with which the satisfaction of the drive was met, as early as the ‘Project’ [1895] and the two papers on the ‘Neuropsychoses of Defence’ (1894a, 1896b) and used the term ‘repression’ quite early on. He now develops the concept properly and has a theory by which the Unconscious is formed through a ‘primal repression’ ( *Urverdrängung*). He can do this, as at the same time he develops the concept of the unconscious. Freud had devoted the last section (F) of the last chapter of ‘The Interpretation of Dreams’ (1900a) to the theme of *Unconscious and Consciousness--Reality*. He wrote there: ‘the most complicated and most rational thought processes can occur without exciting the subject’s consciousness.’ As he underlined: ‘The unconscious is the true psychological reality; *in its innermost nature it is as much unknown to us as the reality of the external world . . .*’<sup>95</sup>

The relation between repression and the unconscious is a complex one. The first time Freud developed a theory of repression was also in chapter VII of ‘The Interpretation of Dreams’, section (E), under the heading: *The Primary and Secondary Processes*. From the theory of hysteria and from dream-processes we know that ‘a normal train of thought is only submitted to an abnormal psychological treatment [primary process] . . . if an unconscious wish derived from infancy and in a state of repression, has been transferred on to it’. As he further indicated: ‘The fulfilment of these wishes [wishful impulses derived from infancy] would no longer generate an affect of pleasure but an affect of displeasure; and it is

---

<sup>95</sup> Freud, S., (1900a), S.E. 5, 612-613. Freud’s unconscious is not that of the philosophers or of Theodore Lipps (1897). The unconscious is the ‘psychical reality’, not to be confused with the ‘material reality’. ‘Everything that can be an object of our internal perception is *virtual*, like the image produced in a telescope by the passage of light-rays.’ (Freud, S., Op. cit., 611) Freud compares the two systems to the lenses of the telescope which cast the image and the censorship between the two systems to the refraction of the rays of light. There are two kinds of unconscious, but one only is the psychoanalytic unconscious, the *Ucs*, inadmissible to consciousness. The other system is like a screen between the *Ucs* and *Cs*, it is the screen of censorship. Consciousness is given the status of a sense-organ for the perception of psychological qualities. *Cs* is a system ‘resembling the perceptual systems *Pcpt*’ (Ibid. 615-616).

precisely this transformation of affect which constitutes the essence of what we term ‘repression’. The problem of repression lies in the question of how it is and owing to what motive forces that this transformation occurs. . . ,<sup>96</sup>

It seems that the reason why ‘psychical repression’ occurred in the first place was precisely the avoidance of unpleasure, the one which resulted from the deception of hallucinatory satisfaction.<sup>97</sup> As for consciousness, it seems to emerge as a peculiar psychical reality or system: ‘But what part is there left to be played in our scheme by consciousness which was once so omnipotent and hid all else from view? *Only that of a sense-organ for the perception of psychical qualities.*’<sup>98</sup>

But, in his paper ‘The Unconscious’ (1915e), Freud presented the view that not all what is in the unconscious is repressed, that the repressed is only part of the unconscious: ‘Everything that is repressed must remain unconscious; but let us state at the very outset that the repressed does not cover everything that is unconscious. The unconscious has the wider compass; the repressed is a part of the unconscious.’<sup>99</sup>

Freud developed in that work the idea that the unconscious is a necessary and legitimate assumption and that ‘we possess numerous proofs of its existence’.<sup>100</sup> It is necessary

---

<sup>96</sup> Freud, S., (1900a), S.E. 5, 598 and 604: The unconscious wishful impulses ‘can neither be destroyed nor inhibited’ and attract repression and censorship. These views are very close to the ones Freud expressed in the ‘Project’, Part I, section [16], S.E. 1, 326-327.

<sup>97</sup> Freud, S., (1900a), S.E. 5, 600-604: ‘This effortless and regular avoidance by the psychical process of the memory of anything that had once been distressing affords us the prototype and first example of psychical repression’.

<sup>98</sup> Ibid., 615.

<sup>99</sup> Freud, S., (1915e), S.E. 14, 166.

<sup>100</sup> Ibid.

because of the gaps in the data of consciousness, and is explained by the existence of numerous latent psychological acts. Serious epistemological problems would arise, if we assumed that latent psychological acts, such as memory, were physiological or somatic processes. What is psychologically unconscious is in a state of latency, asserts Freud. 'The conventional equation of the psychological with the conscious is totally inexpedient.' The unconscious is also a legitimate assumption as 'we only have awareness of our own states of mind, and only infer from them consciousness in other people.'<sup>101</sup> So, as Freud concludes, 'psychoanalysis demands nothing more than that we should apply this process of inference to ourselves also . . . ' and that which 'I do not know . . . must be judged as if it belonged to another person.'<sup>102</sup>

The topographical distinction between unconscious (*Ucs*) and consciousness (*Cs*) is underlined next to the dynamic one. Every psychological act starts by being unconscious and then passes a test (censorship) to find out if it can become conscious by being allowed in the preconscious (*Pcs*). The unconscious comprises both latent and repressed psychological acts. Thus Freud differentiates between an unconscious proper (the repressed) and a dynamic or latent unconscious, which can become conscious being allowed in the preconscious first. There is a rigorous censorship between the first two systems. If we establish another censorship at that end, between preconscious and consciousness, then we have three psychological systems. But basically there are two. Consciousness has an uncertain status, it is seen as an inference (we infer it in other people and some infer it even in

---

<sup>101</sup> Ibid., 169.

<sup>102</sup> 'Als ob sie einer anderen Person angehörten', Freud, S., G.W. X, 268, and S.E. 14, 169.

animals or the inanimate world) and/ or a sense-organ similar to an internal perception, joining therefore the *Pcpt* (perception) system.<sup>103</sup>

These two or three psychical systems have replaced the old  $\varphi, \psi, \omega$  systems of the 'Project'. In 'Letter 52' to Fliess (December 6, 1896) and Chapter VII of 'The Interpretation of Dreams' (1900a), the system  $\psi$  had been replaced respectively by two to three layers of registrations of signs (*Zeichen*) or mnemonic traces or representations (*Vorstellungen*). Here, in the final touches of the first topography (*Topik*) we return to three psychical systems, Freud asks the question if, for each psychical act, or representation (*Vorstellung*) a new record (*Niederschrift*) is needed, if there is, for each inscription, 'a fresh psychical locality' (*Localität*), so that 'the original unconscious registration' lies next to the preconscious one, or if, what happens in each stage is a 'change in the state of the representation.' In other words, do we have different versions each time or the same text, continuously altered?

Freud did not answer the question immediately, as he considered his knowledge of psychical topography not yet complete. He raised the problem of its links to anatomy. Although he recognizes that these links undoubtedly exist, and in particular with the activity of the brain, his position is stated clearly: there is a hiatus between anatomy and the psychical apparatus: 'Our psychical topography has *for the present* nothing to do with anatomy'.<sup>104</sup>

---

<sup>103</sup> Freud, S., (1915e), S.E. **14**, 172-173. On censorship between the systems *Pcs* and *Cs*, see Chapter VII, 'Communication between the systems' (Freud, S., (1915e), S.E. **14**, 190ff; G.W. **X**, 271-272).

<sup>104</sup> Freud, S. (1915e), S.E. **14**, 175.

Psychoanalytic practice favoured several coexisting layers of recorded signs, memories, ideas, representations. It was Freud's clinical observation, that 'if we communicate to a patient some idea which he has at one time repressed . . . our telling him makes at first no change in his mental condition.'<sup>105</sup> Repression is not lifted in that way. The proof is that there is fresh rejection. But, then the patient has the same information in two places, as Freud notes. When he traces the conscious memory back to the unconscious memory, to the earlier repressed idea, repression can be lifted.

In the same paper, Freud questions the vicissitudes of the quantitative components of the drives, the fate of affects. Can we talk about unconscious impulses, emotions and feelings, as we can talk about unconscious representations or ideas? First he repeats emphatically his earlier thesis that 'the antithesis of conscious and unconscious is not applicable to the instincts [drives]', and specifies:

'an instinct[drive] can never become an object of consciousness, even in the unconscious it is only represented by a representation ( *durch die Vorstellung repräsentiert ist*). If the instinct [drive] did not attach itself to an idea or manifest itself as an affective state, we could know nothing about it'.<sup>106</sup>

When we speak about unconscious or repressed instinctual [drive] impulses, 'the looseness of phraseology. . . is a harmless one', as Freud believes. 'We can only mean an instinctual [drive] impulse the ideational representative of which is repressed'. For the same reason, when we speak in psychoanalysis about unconscious love, hate, unconscious consciousness of guilt, or 'unconscious anxiety', it is as meaningless as when we speak about

---

<sup>105</sup> Ibid.

<sup>106</sup> Freud, S., S.E. 14, 177; Freud, S., G.W. X, 275.

‘unconscious drives’.<sup>107</sup> Affects are excitations linked to the drives ( *Triebimpuls*, *Triebregung*). They are usually ‘perceived but misconstrued’. Freud’s view is that, when the drives representative is repressed, the affect’s destiny is either to remain as it is, or to be transformed into anxiety, or to be totally suppressed ( *unterdrückt*), in which case it never comes into existence unless we restore the repression of the representative.<sup>108</sup>

In section V of the same paper under the title ‘The special characteristics of the system *Ucs*’, Freud declares: ‘The nucleus of the *Ucs* consists of representatives of the drive (*Triebrepräsenzen*) which seek to discharge their cathexis; that is to say it is made of wishful impulses [excitations] (*Wunschregungen*).’<sup>109</sup>

Those wishful excitations exist side by side, they do not suffer contradiction, they do not know of time. Two contradictory wishes often find a compromise form. Thus, there is in the unconscious system:

‘no negation, no doubt, no degrees of certainty. All this is only introduced by the work of the censorship between the *Ucs.* and the *Pcs.* Negation is a substitute, at a higher level, for repression. In the *Ucs.* there are only contents, cathected with greater or lesser strength.’<sup>110</sup>

He describes the process of displacement and/or condensation of those quantities from one idea to the other, as ‘distinguishing marks of the primary psychical processes .’<sup>111</sup> These processes are *timeless*, and have little consideration for *reality* (*Realität*). Their special

---

<sup>107</sup> Ibid.

<sup>108</sup> Ibid., 178.

<sup>109</sup> Ibid., 186.

<sup>110</sup> Ibid.

<sup>111</sup> Ibid.

characteristics are: ‘exemption from mutual contradiction, primary process (mobility of cathexes), timelessness, and replacement of external by psychological reality.’<sup>112</sup>

Between the ‘Drives and their Vicissitudes’(1915c) and ‘The Unconscious’(1915e), ‘Repression’ (1915d) develops the theory of a defence mechanism which has been present from the beginnings of psychoanalysis and constituted for a long time its ‘cornerstone’. It was already present in the ‘Studies on Hysteria (1895d). It appeared in Letter 30 May 1896, in which Freud offered Fliess ‘his solution to the aetiology of the psychoneuroses’ with his mapping of the discordances between periods of sexual and psychological development: ‘a surplus sexuality in the psyche is not enough to cause repression, the cooperation of defence is necessary’, he said there. Freud thought then that there was no repression before the age of four.

It was inspired by the clinical observation of resistance and usually referred to, in the early years, simply as defence or as the sole mode of defence. Freud claimed that he did not borrow the concept by any predecessor (although Herbart and Meynert used it, as Strachey indicates). Repression will become one of the destinies of drives, but as Freud will rectify himself, only the drive representative undergoes repression. Again the paradoxes of a drive’s impulse being satisfied and causing, nevertheless, unpleasure, is raised, and addressed with the distinction between two different psychological localities. What is pleasure for one system becomes unpleasure for another. The drive impulse can meet with resistance and undergo repression (the drive’s representative, of course). Normally an external

---

<sup>112</sup> Freud, S., (1915e), S.E. **14**, 187.



stimulus (*Reiz*) would cause flight from it, but: ‘In the case of the drive, flight is useless, because the ego (*Ich*) cannot flee from itself.’<sup>113</sup>

Two remarks are important here 1. That repression is not there from the start, ‘it cannot arise until a sharp cleavage has occurred between conscious and unconscious . . . ’ and that 2) ‘*the essence of repression lies simply in turning something away and keeping it at a distance, from the conscious.*’<sup>114</sup>

Repression will be replaced in due course by ‘rejection based on judgement’. Thus the *Ich* will find an appropriate way to fend off the excitation of the drive by means of those defences, rejection by judgement (*Urteilsverwerfung*) also called *condemnation* (*Verurteilung*).<sup>115</sup> Finally, repression can only occur after the split between the unconscious and conscious psychical activity has taken place.

There are of course other vicissitudes of the drives before repression occurs, that is before the splitting between unconscious and conscious is accomplished, such as the ‘reversal into the opposite or turning round upon the subject’s own self’, as Freud underlines.

---

<sup>113</sup> ‘*Im Falle des Triebes kann die Flucht nichts nützen, denn das Ich kann sich nicht selbst entfliehen*’ (Freud, S., 1915d, S.E. 14, 146; G.W. X, 248).

<sup>114</sup> Freud, S., 1915d, S.E. 14, 147.

<sup>115</sup> Ibid. Judgement, as we know from the ‘Project’[1895], already involves dissection by language. Thus Lacan’s assertion that in Freud ‘the ego is formed of a verbal nucleus’ is justified (‘Science and Truth’, *Écrits*, 1966[1965], Fink 726ff). Rejection (*Verwerfung*) is a different defense mechanism at work in psychosis.

### G. The Schreber Case.<sup>116</sup>

This reference to Freud's psychoanalytic remarks on President Schreber's Autobiographical 'Memoirs' (1911c), published after Formulations (1911b) is justified by the following two reasons: first, because the stage of 'narcissism', a recent discovery in Freud's new developments on the libidinal ego, is used to interpret a case of psychosis (or what he calls the 'narcissistic neuroses'). Second, as a clinical demonstration of the vicissitudes and transformations of libido in psychosis, and an answer to Jung's *Wandlungen und Symbole der Libido* (1912). Freud's 'transformations' follow the rules of logic and grammar of the libido in delusion, rather than other symbolic interpretations. The work deals also with the relations between fantasy and delusion.

While Freud will not find in 'the father complex' and in the homosexual fantasies the determining factor of President Schreber's paranoia – as they can also be met in obsessional neurosis for example – he will retain however their intensity and pathogenic character. This needs, according to Freud, further explanation.

He will summon his libidinal theory and especially the newly defined stage of 'narcissism'. In his old libidinal theory between the initial autoerotism and object-love, a new stage has been inserted since 1910, narcissism. It will be fully developed four years later. Unusual fixations may occur in that stage for some people. Homosexuality is only a phase before the heterosexual choice of object, and it can manifest itself as narcissistic fixation to one's genitals. Those who later become homosexuals have had an unusual fixation to that phase. However, after a heterosexual object – choice has been established, homosexual tendencies

---

<sup>116</sup> Freud, S., (1911 c), S.E. 12, 59-79.

are transformed into social drives, they become sublimated. So, what is different in schizophrenia and paranoia? What are the mechanisms operating in them and what are the symptoms?

In neurotics too, there can be observed a regression to a homosexual choice of object, when, for example, 'social and erotic disappointments' occur, but paranoics oppose fierce resistance to any undoing of their social drives and to their sexualization. It is in that weak spot that Freud finds not only an indication of their fixation to a homosexual phase and hence a disposition to later illness (psychosis), but also something more, a bursting of the banks of libido and a destruction of sublimation in both schizophrenics and paranoics. This seems to lead to either megalomania or delusion which Freud considers to be the symptoms of paranoics.

Freud draws a grammar of the delusion, a map of the 'unconscious' in paranoia:

In all types of paranoic delusion, that is jealousy, erotomania and persecution, a single proposition is contradicted in the unconscious: 'I [a man] love him [another man]', a homosexual phantasy. This proposition actually is not in the unconscious. It has been abolished there. What is in the unconscious is the basic proposition 'I do not love him', contradicting the one that has been abolished and transformed into a series of propositions which take different grammatical forms and lead to the three forms of delusion.

1. In the delusion of persecution the proposition 'I [a man] *love* him [a man]' is transformed first to: 'I do not *love* him, I *hate* him.' The verb is contradicted. Then 'I hate him' is

transformed by *projection* into: ‘he *hates me*’, therefore ‘he persecutes me and thus I am justified in hating him’. Finally ‘I hate him, because HE PERSECUTES ME.’<sup>117</sup>

Two more transformations, logical and grammatical can also occur:

2. ‘I do not love *him*, I love *her*.’ Here it is the object of the proposition which is contradicted.. The person’s internal perception that he is loving becomes, by projection, an external perception, that he is loved instead: ‘I do not love him, I love her BECAUSE SHE LOVES ME.’ This sentence can easily become conscious. The delusion is ‘erotomania’.

3. The third grammatical transformation is: ‘It is not *I* who love the man, *she* loves him’. Here what is contradicted is the subject of the proposition. The form of delusion is *jealousy* and Freud refers both to alcoholic delusions of jealousy and jealousy in women. The delusional proposition ‘*she* loves him’ or ‘he loves *them*’ is again an external perception.

There is also a fourth way of contradicting the internal abolished perception, the proposition ‘*I love him*’ and this new contradictory proposition rejects the former a whole: ‘*I do not love at all-- I do not love anyone*.’ The logical conclusion for the libido in this case is to be all transferred upon the ego, as if the subject was saying: ‘*I only love myself*’ and, as Freud points out, we observe an element of ‘megalomania’ in most paranoic

---

<sup>117</sup> Freud, S. (1911c), The Schreber Case, III, ‘On the Mechanism of Paranoia’ S.E. 12, 63. The main symptom-formation in paranoia is, for Freud, *projection*: ‘The mechanism of symptom-formation in paranoia requires that internal perceptions –feelings - shall be replaced by external perceptions.’

disorders. Megalomania is an infantile remainder, extinguished when there is 'overpowering love' for an object.<sup>118</sup>

Projection, however, as Freud observes, was a general psychological mechanism, met in other psychological conditions 'and in our general attitude towards the external world'. He leaves its development 'for another occasion' which makes Strachey note that one of the lost metapsychological papers might have dealt with projection. As 'the characteristic symptom-formation' in paranoia it is described as follows:

'An internal perception is suppressed, and instead, its content, after undergoing a certain form of distortion, enters consciousness in the form of an external perception. In delusions of persecution the distortion consists in a transformation of affect; what should have been felt internally as love is perceived externally as hate'.<sup>119</sup>

The other mechanism in operation in paranoia is 'repression'. It follows the *fixation* of a certain libidinal current in the unconscious. This current behaves like one that is repressed, and repression is better understood if it is dissected in three stages: 1) the above mentioned *fixation* of the drive component in the unconscious, 2) repression proper or 'after-pressure, emanating from the more highly developed systems of the ego'<sup>120</sup> 3) Then there is a *failure of repression, the return of the repressed*.

In Schreber's case the end of the world feeling appears only at the climax of his illness, when an imminent world-catastrophe leaves him the only 'real man' alive. During this phase 'his ego was retained, and the world sacrificed'. His initial persecutory feelings were

---

<sup>118</sup> Op. cit., 65.

<sup>119</sup> Op. cit., 66.

<sup>120</sup> Op. cit., 67. Attraction from the unconscious trend and repulsion from the ego lead to a strengthened repression.

the consequence of his conflict with Professor Flechsig during his first hospitalisation, which he later explained to himself as due ‘to the indissoluble bond which had been formed between him and God.’<sup>121</sup>

In Schreber’s case the persecutory feeling and the delusion of imminent catastrophe does not lead to a complete withdrawal from the object, and, at a second moment, they become ‘a process of reconstruction, an attempt to recovery.’<sup>122</sup> If the end of the world feeling had to be attributed to the complete withdrawal of libido from the external world, how can it consequently be turned into the megalomaniac delusion of becoming the saviour of the world? And what is causing persecution at the onset of the illness, anyway? Freud will try to answer these questions in the course of his study of the case.

He describes the essential mechanism in paranoia as the detachment of libido from the external object, but surely, as he notes, this takes place in other cases too without such disastrous consequences, in cases of mourning, and in normal cases when people detach their libido from other people without falling ill. ‘It cannot in itself be the pathogenic factor in paranoia’, as Freud observes.<sup>123</sup>

Detachment of the libido in paranoia has special traits, it is ‘put to a special use.’ After it has been withdrawn from the object, it will manifest itself as megalomania. ‘It becomes attached to the ego and is used for the aggrandizement of the ego’. As Freud concludes: ‘On the basis of this clinical evidence . . . paranoics have brought along with them a

---

<sup>121</sup> Op. cit., 69.

<sup>122</sup> Op. cit., 71.

<sup>123</sup> Op. cit., 72.

fixation at the stage of narcissism . . . [a regression] back from sublimated homosexuality to narcissism.’<sup>124</sup>

In Schreber’s case, what we note first, as Freud points out, is a partial detachment of the libido from the figure of Flechsig. This is followed by a return to the object Flechsig but with a negative sign, a delusion of persecution. There is a continuous battle between complete and partial ‘repression’ of libido, between persecution and megalomania, until it spreads to the whole world and to the whole of the ego. At the end, the whole of the world has to come to an end and the ego will survive by making an alliance with God followed by a delusion of redemption of the world by Schreber.<sup>125</sup>

Freud will continue to ask those questions until the end of the paper. Does the complete withdrawal of libido upon the ego justify the end of the world feeling, or is there still some rapport with the external world? Are the ego-cathexes<sup>126</sup> libidinal or non-libidinal, partially or totally? Does a disorder of cathexis in object-libido affect the ego-cathexes? If yes, then the opposite should also be true. Freud feels yet unprepared to answer them. He only stresses that: ‘We regard drives as being the concept on the frontier-line between the somatic and the mental, and see in it the psychical representative of organic forces. Further we accept the popular distinction between ego-drives and a sexual drive’.<sup>127</sup>

---

<sup>124</sup> Ibid.

<sup>125</sup> Freud said earlier that a feeling of the end of the world may also be found ‘at the climax of the ecstasy of love.’ An example is taken from Wagner’s *Tristan und Isolde*: one object absorbs the totality of libido.

<sup>126</sup> *Ichbesetzungen* can be translated either as cathexis by the ego or cathexis of the ego. The genitive is either subjective or objective. The meaning is ambiguous. It is clarified later as ‘cathexis by the ego’. A synonym is *Ichinteresse*.

<sup>127</sup> Freud, S., (1911 c), op. cit., S.E. **12**, 74.

Disturbances of the libido may affect the ego- cathexes and the reverse: abnormal changes in the ego can disturb the libidinal processes. But there is no further elaboration of what those alterations of the ego characteristic of psychosis may be. One thing only is certain, as Freud says: it cannot be asserted that the paranoics withdraw completely their interest from the world. They only lose their libidinal interest in it. Complete withdrawal of interest in the world occurs only in what is known as ‘Meynert’s amentia’, in other words acute hallucinatory confusion.<sup>128</sup>

Finally Freud considers the differences between schizophrenia/ dementia praecox and paranoia. Abraham pointed out that turning away of the libido from the external world is a particularly clearly marked feature of *dementia praecox*, where a struggle takes place between repression and the residues of former cathexes, as Jung had noted. An attempt to recovery is done through hysteriform symptoms – deliria and motor stereotypes – rather than through delusional constructions. The prognosis is more unfavourable. Regression goes beyond narcissism and megalomania to a complete loss of object love and a return to infantile auto-eroticism.

The dispositional fixations in schizophrenia go back to an even earlier stage than narcissism. But paranoid features may develop into schizophrenia and the two forms may become combined. Schreber’s case, as Freud concluded, was a case of combined paranoid dementia, and its favourable end may be attributed to ‘a father-complex . . . in the main positively toned . . .’<sup>129</sup>

---

<sup>128</sup> Op. cit., 75.

<sup>129</sup> Op. cit., 78.



Freud finds in Schreber's delusional constructions a demonstration of his libidinal theory. His ray-connexions with God are the endopsychic perceptions of the libidinal processes. Projection and introjection of libidinal cathexes are illustrated in the perception of his ego attracting all the rays of God to itself, then using them to reconstruct the world. Thus Freud's libido theory and Schreber's delusion are compared as the two sides of truth of a conflict between sexual libido and the ego, ego and libido.<sup>130</sup>

---

<sup>130</sup> Op. cit., 79.

## CHAPTER 3

### IDENTIFICATION IN FREUD

#### A. 'The third Freud'

It is now time to examine Freud's developments during the period known as 'third Freud'<sup>1</sup>. They start with 'Beyond the Pleasure Principle' (1920g). This work constitutes a turning point in Freud's metapsychological edifice<sup>2</sup>. It is here that he will add the third factor to that edifice, the economic one, next to the 'topographic' and the 'dynamic'. He will deal with the strange destiny of unpleasure in psychic life. His aim is to replace his old distinction between ego-drives and sexual drives as insufficient, by a new distinction between life-drive ( *Eros*) and death drive ( *Thanatos*) based on his hypothesis of a 'primary masochism'<sup>3</sup>. He makes us believe that there is an equivalence between the 'Nirvana Principle', newly introduced by Barbara Low with his own 'Pleasure Principle,' although he aims at something more radical as he refers to 'the mysterious masochistic trends of the ego'<sup>4</sup> which may upset the wish-fulfilling tenor of dreams.

Freud had initial reservations about adding other drives to his earlier theory of only two sets of drives, the ego-drives ( *Ichtriebe*) or self-preservation drives ( *Selbsterhaltungstriebe*) and

---

<sup>1</sup> According to Jean Florence in his thesis, 'Identification in the Freudian Theory' ( *L'identification dans la théorie freudienne* 1978), which we examine below, it seems that Lacan distinguished three periods in Freud's work, *Freud I* (1891-1913), a period from 'On Aphasia' to 'Totem and Taboo', *Freud II* (1914-1918), from 'On Narcissism; an Introduction' to 'Introductory Lectures to Psychoanalysis' (1914-1917), and finally *Freud III*, after 1918. As for Freud himself he wrote in a letter to Ferenczi in 1912, that his good work seemed to follow a seven year cycle, starting from 1891 to 1898, then from 1898 to 1905, and the third from 1905 to 1912 when he was writing this letter.

<sup>2</sup> Freud himself had introduced the term 'metapsychology' in a letter to Fliess (10 May 1898), as he himself tells us in 'Beyond the Pleasure Principle' (1920g), S.E. 18, 7.

<sup>3</sup> Freud, S., (1920g), S.E. 18, 54-55.

<sup>4</sup> *Ibid.*, 13-14.

the sexual drives, although he accepted the possibility of other drives existing, for example, ‘of play or destruction or of gregariousness . . .’<sup>5</sup> All this, despite the fact, that he had recognized earlier that, during primary narcissism, *hate* makes its appearance next to *loving*, or possibly before love, and can develop to an ‘aggressive inclination’ and ‘an intention to destroy the object’.<sup>6</sup>

The clinical observation of the traumatic neuroses, the war neuroses and the compulsion to repeat lead Freud to the hypothesis of the existence of a death drive, *Thanatos*, next to a life drive, *Eros*, and thus to a new set of drives to replace the old distinction between ego-drives and sexual drives. *Eros*, is the life preserver force, the unifying the drives reservoir of libido, which resides in the *id*, and *Thanatos* is the destructive drives, the defusion of drives. A new topography is developed to show it, but the complications mount as Freud does not manage to make clear distinctions in the topography of the new instances. ‘The Ego and the Id’ (1923b), ‘Masochism’ (1924c), the much later written text, ‘The Splitting of the Ego in the Process of Defence’ (1940e [1938]) and the theoretical summary of the same year, ‘Outline of Psychoanalysis’ (1940a [1938]) are his successive theoretical developments not only of the new set of drives, but also of new distinctions in the ego and of new clinical entities. The ego ideal, initially responsible for repression, recedes in the background as a mere function of the instance of the superego which will slowly take centre stage in Freud’s third period. However, the ego ideal will continue to operate in another context, in the context of the

---

<sup>5</sup> Freud, S. (1915c), S.E. **14**, 124. A footnote in the first of the ‘Three Essays’ (1905d) was added in 1924 stating

Freud’s view of the existence of primary masochism (1905d, S.E. **7**, 158).

<sup>6</sup> Freud, S., (1915c), S.E. **14**, 136-137.

theory of identification in ‘Group Psychology and the Analysis of the Ego’ (*Massenpsychologie und Ich-Analyse*, 1921c), which also belongs to the ‘third Freud’.

In the second topography, *das Ich* is described as something like the ‘total person’ (*die gesamte Person*), which extends into the id, while its resistances and defences are proven clinically to be unconscious, therefore springing from the id (*das Es*). Hence the ego is partly unconscious and therefore not as ‘autonomous’ as it seems. It has four functions or institutions, *censorship* as exercised by the superego, *reality-testing*, *repression*, and finally *consciousness* and *motor functions*. The figuration of the second topography is curious and unsatisfactory, and Freud tried to represent it as an entity, a ‘sphere within a sphere’, with cuts, protuberances and caps. In that pear shaped entity Freud differentiated between the ‘entire ego’ (*das gesamte Ich*) and the ‘repressed’, a cut below the ego, communicating with the area of the ‘unconscious ego’ which he called ‘*das Es*’, the ‘id’, borrowing a term from Groddeck. Two protuberances were added, the perception-consciousness (*Pcpt-Cs*) sitting as ‘an ovum on a germinal cell’ at the top, and the ‘hearing cap’ of the superego.

A lot of the propositions of the first topography (*Topik*) have thus been rearranged conceptually and topographically. The ego is the ‘bodily ego’, but also the precipitate of all the past erotic object-choices, by identification. Most importantly, a new grade in the ego, the *superego*, replaces or encompasses the function of the *ego ideal*, and takes in a sublimated, ‘desexualized’ libido. It has links with the archaic father, but also with both oedipal figures, father and mother. It also has links with the *id*, as the reservoir of the libido.<sup>7</sup>

---

<sup>7</sup> Freud did not make up his mind concerning the question whether *the ego* was the ‘reservoir of the libido’ (as he stated in his paper on ‘Narcissism’, 1914c) or, if it was *the id*, as he argued in ‘The Ego and the Id’ (1923b). In

The consequences of the introduction of the two sets of drives are shaping the second topography, but the conception is fuzzy. What interests us more are its uncertainties, contradictions, and drawbacks, highlighted by Lacan in his Seminar *L'insu que sait de l'une-bévue s'aile à mourre*' (1976-1977), Book XXIV, to which we make some references later in this chapter. These impasses leave the terrain open to consider the possibility of a third topography (*une troisième topique*) in that same period of the 'third Freud', as Lacan did. We can find it in Freud's sole development of the concept of identification in Chapter VII of 'Group Psychology and the Analysis of the Ego' (1921c). Wanting to analyse the psychic processes in groups and the love life, he proposed a structure comprising external object, ego and ego ideal, and developed three kinds of identification at least. The term and psychological notion of 'identification' had been used by Freud in the clinical cases of hysteria, in the analysis of dreams and in transference, without a conceptual development until then. Identification leads us back to the heart of the subject's/ego's formation. Lacan suggested that Freud's development of identification was his third topography (*troisième topique*).<sup>8</sup> Freud's theory of identification was written a year after 'Beyond the Pleasure Principle' (1920g), and according to Jean Florence in his thesis 'Freud's Theory of Identification', published in Brussels in 1978, it constituted a retrograde step in relation to the theoretical advances of 1920, especially the hypothesis of the death drive. Florence only saw it as an extension of Freud's theory of narcissism. Thus he adopted the general view that

---

his 1922 Encyclopaedia article *The Theory of the Libido* (1923a, S.E. 18, 257), he had already made the *id* the reservoir of the libido. But, in *An Outline of Psychoanalysis* (1940a [1938]), it was again the *ego*.

<sup>8</sup> Lacan devoted a whole year of his Seminar to the theme of *Identification* (1961-1962). His follower and analysand Claude Conté contributed his own development in his paper: 'The Splitting of the Subject and its Identification' (*Le clivage du sujet et son identification*, Paris 1970) and further enhanced Lacan's topological advances of the 1960s in his last paper *Topologiques (Surfaces)* 1993.

all identification in Freud is narcissistic with one exception only, ‘identification to the traumatic signifier’ in Freud’s analysis of the Wolfman. <sup>9</sup> Freud insisted on differentiating identification from love, called the second identification a regression from love, and reserved a special place to a form of identification before any object relation (first identification to the archaic father). As for the third form of identification no love-link was necessary. <sup>10</sup>

After ‘Group Psychology and the Analysis of the Ego’ (1921c), and especially after ‘The Ego and the Id’ (1923b), Freud continued with metapsychological developments in different directions, some related to the previous period, some new. He emphasised various aspects of his second topography in Lecture 31 of his ‘New Introductory Lectures to Psychoanalysis’ (1933a)<sup>11</sup>, but also developed a new theory of anxiety in ‘Inhibition, Symptoms and Anxiety’ (1926d) based on the concept of castration and its effects on the subject. It was not unrelated to the importance he was giving now to the superego. He wrote ‘The Economic Problem of Masochism’ (1924c) with a different view on masochism than in ‘Drives and their Vicissitudes’ (1915c). With ‘Negation’ (1925h) he developed a new form of defence, and in ‘Fetishism’ (1927e) he developed a new clinical structure, perversion, which used that mechanism of defence, denial, in particular. A straight line from the latter developments led him to the formulation of a split in the ego which was not a new discovery in itself, but contained a new structural meaning for the neuroses and the psychoses: ‘The Splitting of the Ego in the Mechanisms of Defence’ (*Die Ichspaltung im Abwehrvorgang*), 1940e[1938] was one of two texts of the final year of his life, posthumously published. A rift in the ego was

<sup>9</sup> Freud S., (1918b [1914]): ‘From the History of an Infantile Neurosis’, S.E. 17, 7ff. The case ushers in the ‘third Freud’.

<sup>10</sup> Lacan also spoke of Freud’s three main sorts of identifications as three different modalities of the lack of object *privation*, *frustration*, and *castration* and introduced it as object *a*, ‘cause of desire’, in his Seminar IX, *Identification* (1961-62)

<sup>11</sup> Freud, S., (1933a): ‘Lecture XXXI, The Dissection of Personality’, S.E. 22, 57-80.

said to be the result of defence against castration, the object in question was the phallus, denial and not repression was used as defence mechanism against the original anxiety of castration. The other posthumously published text written in the same year, ‘Outline of Psychoanalysis’ (1940a [1938]), contained his testament on psychoanalysis, its doctrine and its clinical practice <sup>12</sup>.

### **B. The shift inaugurated by ‘Beyond the Pleasure Principle’ (1920g)**

The problem Freud faced with the pleasure principle was that a remainder of unpleasure (*Unlust*) manifested as a symptom after the repression or rejection of certain forms of satisfaction which were not allowed in the secondary processes or even in the primary processes. In the first topography, repression was the mechanism by which ‘the ego’ dealt with unpleasure. In the metapsychological papers of the ‘second Freud’ the problem was resolved topographically, but not entirely. Repression was not always or not totally successful. In neuroses the repressed would return in the form of symptoms and other unconscious formations, usually as a compromise, a gain of pleasure within the unpleasure. <sup>13</sup>

The dream’s postulate of the fulfilment of desire, often left an enigmatic remainder, which means that, while a wish was fulfilled ( *Wuncherfüllung*), another deeper tendency, a certain desire (unconscious) never met its fulfilment, remained radically unsatisfied <sup>14</sup>.

---

<sup>12</sup> Freud, S., (1940a [1938]), ‘Outline of Psychoanalysis’, S.E. **23**, 144-207

<sup>13</sup> ‘... all neurotic unpleasure is of that kind- pleasure that cannot be felt as such’, (Freud, S., 1920g, S.E.**18**, 11.

<sup>14</sup> Take for example a dream like the one Freud referred to at the end of ‘Formulations’ (1911b): A man dreamed that his dead father was alive, but his joy was accompanied by an unpleasant feeling which seemed to be stemming from the sense that his father ‘did not know that he was dead’. Freud completed what was missing from the sentence of the dreamer: that he was dead ‘according to his wish’ (of the dreamer). This wish is ‘unconscious’. As Lacan argued, in the dream the dreamer’s ego is in one place, and the subject is in another, the subject is not there at the right moment to ‘register’ the wish. While the dream procures pleasure in representing the wish as fulfilled (seeing the father alive), the unpleasant feeling is the remainder of an impossible meeting

In the later years, as the third period of Freud's work sets in, the superego will more and more play an important role in structural modifications due to defence regarding sexual enjoyment. A certain enjoyment will be felt as a danger for its object, as the threat of castration, the apparent 'unity' of the ego is under question under a certain kind of defence, which Freud called splitting ( *Spaltung*). The threat of losing the object is accompanied by unpleasant feelings, and especially by the affect of anxiety.

First, Freud treated some clinical manifestations of unpleasant feelings— the traumatic neuroses - which showed the clearest departure from the dominance of the pleasure principle. Wanting to bring in the economical point of view, Freud goes as far back as the 'Project' (1950a [1895]), where the tension of desire was accompanied by a certain excess in excitation alias called there *neuronal quantity* ( $Q_n$ ). Rising beyond a certain threshold, tension would cause unpleasure, the lowering of its level would cause pleasure. But, as we said in Chapter 1, the rule of inertia, of the lowest possible tension, was not 'a simple relation of the strength of feelings of pleasure or unpleasure and the corresponding modifications in the quantity of excitation'<sup>15</sup>; the number of repetitions mattered too. But, now, beyond the formula, Freud is in search of a psychological or even philosophical theory, that would provide him with an answer as to 'the meaning of the feelings of pleasure and unpleasure which act so imperatively upon us'. They constitute 'the most obscure and inaccessible region of the mind'.<sup>16</sup>

---

with 'truth', the truth of desire (Lacan J., 1958-1959, ' *Desire and its Interpretation* ', Seminar Book VI, 10 December 1958, recorded copy). As he underlined, the subject does not know, 'the father is unconscious'.

<sup>15</sup> Freud, S., (1920g), S. E., **18**, 8. For Fechner's law of constancy and Freud's modification of it, this thesis, Chapter 1, p. 50, note 76. Freud calculated the increase or lowering of the quantity of excitation according to a formula similar to Fechner's, but taking into account the duration and number of repetitions of the excitation.

<sup>16</sup> Ibid., 7. This was developed as the 'mysterious masochistic tendencies of the ego', a phrase which Freud used in 'Beyond the Pleasure Principle', S. E., **18**, 63) and in 'The Economic Problem of Masochism' (1924c.)



As Freud distinguished:

‘to relate pleasure and unpleasure to the quantity of excitation that is present in the mind but is not in any way “bound” and to relate them in such a manner that unpleasure corresponds to an *increase* in the quantity of excitation and pleasure to a *diminution*....[but] in a *given period of time*’<sup>17</sup>.

He quoted from Fechner’s work: ‘*Einige Ideen zur Schöpfungs- und Entwicklungsgeschichte der Organismen*’ (1873) where Fechner formulated the ‘principle of constancy’ or tendency towards ‘stability’. This is how he himself had arrived at the pleasure principle: ‘The pleasure principle follows from the principle of constancy: actually the latter principle was inferred from the facts which forced us to adopt the pleasure principle.’<sup>18</sup>

In the ‘Project’ , Freud had called that principle ‘inertia’. Keeping the tension as low as possible, and keep it *constant*, as he now says, was the aim of the psychical apparatus, a hypothesis similar to Helholz’s ‘homeostasis’ and which goes as far as to include a tendency to fall at level zero.

Freud always said that the pleasure principle was indeed an unpleasure principle and absolute dominance of the pleasure principle was not corroborated by human experience, It was rather a ‘tendency’, like it was a ‘tendency towards stability’ that dominated the psycho-physiological processes in Fechner’s law.<sup>19</sup>

---

<sup>17</sup> Ibid.

<sup>18</sup> Ibid., 9

<sup>19</sup> Ibid.

The first opposition to the unpleasure principle by other forces took the form of ‘inhibition’, a ‘primary method’, inefficient, and highly dangerous for that too, as Freud underlined. The reality principle, more efficient, replaced the pleasure principle and safeguarded it through the ‘postponement of satisfaction’. This brings some unpleasure too. More importantly, ‘unpleasure for the highly organized ego’ will have its origin in those drives which in the course of its development have ‘split off’<sup>20</sup> from the ego, the sexual drives.

Besides those two cases of defence against unpleasure used by the ego (inhibition and repression), there is a third one. Freud says that most of the unpleasure we experience is ‘perceptual unpleasure.’ It causes a situation of ‘perceptual danger’, either coming from pressure by the unsatisfied drives, or from an external perception ‘distressing in itself or exciting unpleasurable expectations. This is perceived as a danger. Freud is very precise here. Such a perception, as Freud says, could be directed correctly by the pleasure principle and need not limit its dominance. However, at that point, as Freud notes, things are not so simple; the psychical apparatus seems to react in curious ways which challenge our idea of the dominance of the pleasure principle. Dreams in the traumatic neuroses are an example.

With the ‘perceptual danger’ put forward by Freud as cause of upset in the economy of the pleasure principle, three sorts of relation to danger are evoked: Anxiety (*Angst*), fear (*Furcht*) and fright (*Schreck*), the first one as preparation to the danger, even if the object is unknown, the second as a reaction of flight before the object causing it, the third has the effect of shock

---

<sup>20</sup> Ibid., 11: ‘. . . individual drives or parts of drives turn out to be incompatible in their aims or demands with the remaining ones, which are able to combine into the inclusive unity of the ego’. They ‘are then split off from this unity by the process of repression, held back at lower levels of psychical development and cut off . . . from the possibility of satisfaction.’

and surprise. In the traumatic neuroses the decisive factor seems to be fright, stemming from surprise. In the war neuroses and the traumatic neuroses, motor symptoms develop similar to the ones in hysteria, but with a stronger 'subjective ailment'. Secondly, a real wound or injury inflicted simultaneously works as a rule against the development of neurosis. Fear has a definite object, as for anxiety it is a certain state of expectation of danger and the preparedness for it. In a strange way anxiety seems to protect a subject against fright, and so against the 'fright- neuroses', as Freud underlines.<sup>21</sup>

The study of dreams occurring in the traumatic neuroses showed that those dreams tried to bring the subject repetitively back to the traumatic experience. As Freud noted, some people are not astonished by it. They say that this is due to a fixation to the traumatic experience similar to a hysteric's fixation. In the 'Studies on Hysteria' (1895d), Freud stated that 'hysterics are suffering from reminiscences', that their symptoms are a proof of that, but in the traumatic neurosis people rather try not to think about their traumatic experiences. So, something must be present which upsets 'the 'wish-fulfilling' tenor of dreams,' and divert it from its purpose. Perhaps, as Freud remarks, we come here across 'the enigmatic masochistic trends of the ego.'<sup>22</sup>

Freud noted that a recent review of psychoanalytic theories about children's play did not notice 'the economic motive' involved in them, that is the repetition of an unpleasant

---

<sup>21</sup> Freud, S., 1920g, 13. Often Freud does not make the distinction between fright and angst. This is what Strachey notes. Ibid. n. 1.

<sup>22</sup> Ibid., 13-14. Cf., Freud, S., G.W. 13, 11. *Oder wir mußten der rätselschaften masochistischen Tendenzen des Ichs gedenken.*

experience for a 'yield of pleasure' (*Lustgewinn*)<sup>23</sup>. He brought in as a demonstration of the latter his famous observation of his grandson's play with the wooden reel at the age of 18 months, known as the '*Fort – Da*' game.

The young child had the habit of throwing his toys away with distinct pleasure. He accompanied their disappearance with the sound o-o-o. Once, during his mother's short absence, he played at throwing his wooden reel over his cot and retrieving it – he repeated the two sequences of that game 'untiringly' and accompanied them with two distinct vocalisms, o-o-o, da . . . which Freud interpreted as *fort* (away, off, gone), *da* (here). In still another play, when the mother went away for several hours, the child greeted her in her return with the words: 'baby o-o-o'. Freud noticed that while the mother was away, the child staged his own disappearance from the mirror, thus making 'the baby gone'.<sup>24</sup>

Although Freud first used this as the example of repetition of an unpleasurable experience for the mastery of it, and involving a yield of pleasure, thus not contradicting the pleasure principle itself, he was still looking for a more primitive and obscure motive which would go 'beyond the pleasure principle'. 'Beyond the pleasure principle' (1920g) lead Freud to more primitive tendencies, which were independent from it<sup>25</sup>. He turned to another manifestation,

---

<sup>23</sup> A consideration of the yield of pleasure (*Die Rücksicht auf Lustgewinn*, G.W. **13**, 11), Freud, S. (1920g), S.E. **18**, 14. Freud refers to Pfeifer's 1919 publication, 'Expressions of infantile-erotic drives in play' (*Ausserungen infantil-erotischer Triebe im Spiele*) *Imago*, **5**, 243.

<sup>24</sup> Freud, S., (1920g) S.E., **18**. 14-15. Freud found in those sequences and especially in the sequence of the child making the reel, another toy or himself disappear a distinct element of a gain of pleasure during the repetition of an unpleasant experience, which he related either to the use of the symbol itself or to the mastery of an unpleasant situation, the mother's absence. Other elements related to the drive may have contributed to the gain of pleasure, such as the transformation of a passive experience into an active one, or the desire for revenge for the mother's absence, etc. Lacan interpreted the game as an example of the use of the symbol as a cut preceding the introduction of the symbolic order, and not as an imaginary mastery of the mother's absence. (in Lacan, J., *Ecrits* (1966), op. cit., 392.

<sup>25</sup> Freud, S., (1920g), S.E. **18**, 17.

the repetition of unpleasant early childhood experiences within the psychoanalytic treatment. As he explained in the third part of this work with the utmost simplicity, the aim of the treatment, since it started twenty-five years earlier, had shifted. Initially analysis was ‘an art of interpreting’, where the analyst would communicate unconscious knowledge to the patient, therefore, what the patient did not know from the unconscious material. But soon the patient’s resistances would hinder the therapeutic process, and this could not be resolved unless a confirmation of the correct interpretation was sought from the patient overcoming his resistances. For that a certain change in the technique was needed, an amount of ‘suggestion operating as transference’ in order to ‘persuade’ the patient to abandon his resistances and remember early experiences. But, as Freud notes in his 1920 text, precisely at that stage, the patient cannot remember the most essential part of what has been repressed: ‘He is obliged to repeat the repressed material as a contemporary experience instead of, as the physician would prefer to see, remembering it as something belonging to the past’.<sup>26</sup> As Freud added:

‘These reproductions, which emerge with such unwished-for exactitude, always have as their subject some portion of infantile sexual life- of the Oedipus complex that is and its derivatives’; and they are invariably acted out in the sphere of transference, of the patient’s relation to the physician.’<sup>27</sup>

While ‘transference neurosis’ is in operation replacing the earlier neurosis, the ‘physician’ will endeavour: ‘To force as much as possible into the channel of memory and to allow as little as possible to emerge as repetition’. But, the physician cannot spare the patient this phase of treatment.

---

<sup>26</sup> Ibid., 18.

<sup>27</sup> Ibid.

‘He must get him to re-experience some portion of his forgotten life, but must see to it, on the other hand, that the patient retains some degree of aloofness, which will enable him, in spite of everything, to recognize that what appears to be reality is in fact only reflection of a forgotten past.’ Only then ‘the patient’s sense of conviction is won, together with the therapeutic success that is dependent on it.’<sup>28</sup>

The ‘compulsion to repeat’ (*Wiederholungszwang*), a term which appeared as early as 1914 in the paper *Recollecting, Repeating and Working Through* (1914g), became here a major theme.<sup>29</sup> Freud underlined that the compulsion to repeat which arises in psychoanalytic treatment is due to resistances which are unconscious while for the earlier Freud, ‘the repressed offers no resistance.’<sup>30</sup> Here Freud offered a correction saying that the motives for, and even the resistances themselves, were unconscious. Here the earlier topographic distinction between conscious and unconscious did not help, and Freud replaced it with the distinction between ‘the entire ego and the repressed.’<sup>31</sup> He added: ‘It is certain that much of the ego is itself unconscious, and notably what we may describe as its nucleus; only a small part of it is covered by the preconscious.’<sup>32</sup>

Freud made a rectification by distinguishing the resistances which stem from the ego<sup>33</sup> and the compulsion to repeat (he called this ‘the systematic approach’) from the repressed (‘the dynamic approach’). They both operate within the pleasure principle, but, as he says, our analytic efforts towards lifting repression meet the compulsion to repeat half-way and

<sup>28</sup> This makes a reference to his paper ‘*Recollecting, repeating, and working through*’ (1914g).

<sup>29</sup> Freud, S., (1920g), S.E. **18**, 19.

<sup>30</sup> Ibid. ‘Resistance during treatment arises from the same higher strata and systems of the mind which originally carried out repression.’

<sup>31</sup> Ibid. We object to the translation of ‘*das gesamte Ich*’ as the ‘coherent ego’, by Strachey. *Gesamt* means whole, entire, all. It is the ego together with the id and the other instance, the superego, and only the repressed is split off from it, but remains within the id. Our examination of Lagache’s paper on the Structure of the Personality in Chapter 4 will address the questions of the Second Topic again.

<sup>32</sup> Ibid.

<sup>33</sup> As Strachey notes (Op. cit., S.E. **18**, 20 [n. 1]), ‘a fuller and somewhat different account of the sources of resistance will be found in Chapter XI of ‘*Inhibitions, Symptoms and Anxiety*’ (1926d).

procure some tolerance of the unpleasure. Surely the experiences which the compulsion to repeat brings to the fore, although unpleasant, do not contradict the pleasure principle. The activities of repressed instinctual impulses (drives) may cause unpleasure for the ego, but what is unpleasure for one system, is simultaneously satisfaction for the other. This is the basis of the pleasure principle.

But the compulsion to repeat will bring to life some experiences which had never been pleasant. This is a manifestation of what Freud calls 'the demonic power' at work in repetition, its 'malignant power' which is well observed in the analysis of neurotics, as a transference phenomenon and even in the lives of some normal people. While Freud is able to say that most of the compulsion to repeat lies within the sphere of influence of the pleasure principle, in some cases, he believes, there is in the compulsion to repeat 'something more primitive, more elementary, more instinctual than the pleasure principle and over-rides it,'<sup>34</sup>

Then he addressed the question of the compulsion to repeat using biology and speculation.<sup>35</sup> As he admitted, perhaps his hypothesis did not go further than that which anatomy postulated, but gave a better explanation as to why consciousness was on the surface of the brain, and not protected deeper within.<sup>36</sup>

---

<sup>34</sup> Freud, S., 1920g, S.E. **18**, 22-23.

<sup>35</sup> *Ibid.*, Section IV, pp. 24-29.

<sup>36</sup> Freud takes an example from biology, the 'undifferentiated vesicle of a substance', the simplest form of the living organism whose surface is 'susceptible to stimulation' and 'turned towards the external world'. It is a picture of the nervous system 'confirmed by embryology' which he first put forward in the 'Project' although not in these terms, as he admits. He stressed the importance of the 'protective shield' against stimuli developed by that same organism. The crust of the substance becomes permanently modified, 'baked through'

As he postulated in the ‘Project’, there were resistances in the transmission of excitation, of nervous energy between the nervous cells. <sup>37</sup> The contact-barriers were in place for that reason. A lot of the ‘Project’s hypotheses were taken up here again, but not in a neurological language, rather using biology and sometimes still the physical and mechanical hypotheses. Freud, will finally make a speculative use of Weismann’s biological hypothesis about the eternal life of germ-cells. He used it in order to introduce a new hypothesis, a new duality of the drives, *Eros* and *Thanatos*. The compulsion to repeat is freed from the pleasure principle and will be related to the ‘death drive’. As Freud said: ‘If there is a ‘beyond the pleasure principle’ it is only consistent to grant that there was also a time before the purpose of dreams was the fulfilment of wishes. <sup>38</sup> The dreams in the traumatic neuroses and the war-neuroses are placed in that last category, even if their ultimate aim is to facilitate the return of the pleasure principle by developing anxiety and mastering the traumatic stimuli. Hence, the drive element related to the compulsion to repeat is ‘an urge inherent in organic life to restore an earlier state of things . . .’ <sup>39</sup>

Freud’s new duality of the drives starts with the ‘death drive’, which is ‘the aim of all life’, organic life, that is. This theory leaves the self- preservative drives greatly diminished, as ‘instinctual life, as a whole, serves to bring about death.’ <sup>40</sup> As a result the sexual drives are

---

<sup>37</sup> The particularities of transmission of excitation which were first presented in the ‘Project’ and the hypothesis of two forms of energy in the psychological systems, a bound and an unbound energy, which Breuer had introduced from physiology in his theoretical contribution in the ‘Studies on Hysteria’ (1895d), are here still valid for Freud, although he recommends some caution (Freud, S., 1920g, S.E. 18, 31).

<sup>38</sup> Freud, S., (1920g), S.E. 18, 32.

<sup>39</sup> Ibid., 36.

<sup>40</sup> Ibid., 39.



going to be redefined as *Eros* becoming now ‘the preserver of all things,’ while the ego-drives are equated with the ‘death drives’.<sup>41</sup>

### C. Why a second topography?

As Freud argued in ‘Repression’ (1915d):

‘Psychoanalytic observation of the transference neuroses leads us to conclude that repression is not a defensive mechanism which is present from the very beginning, and that it cannot arise until a sharp cleavage (*eine scharfe Sonderung*) has occurred between conscious and unconscious mental activity.’<sup>42</sup>

Having underlined ‘the extent to which repression and what is unconscious are correlated’, he then deferred ‘probing more deeply into the nature of repression’, until he knew more ‘about the unconscious, about its structure, about the structure of the succession of psychical agencies which constitute it.’<sup>43</sup>

However, the investigation of the *unconscious* in his homonymous work (1915e) presented him with other problems.<sup>44</sup> Despite those, Freud maintained the distinction between conscious and unconscious psychical activity for practical, clinical reasons, and made a topographical separation between *Cs.* and *Ucs.* the two recordings in two or three different

---

<sup>41</sup> Ibid., 52.

<sup>42</sup> Freud, S., (1915d), S.E. **14**, 147. *Sonderung* means ‘specialization’, ‘differentiation’. Strachey translates *Sonderung* as ‘cleavage’.

<sup>43</sup> Ibid., 148.

<sup>44</sup> First he realized that, although ‘everything that is repressed must remain unconscious...the repressed does not cover everything that is unconscious’. Thus, as he concluded: ‘The unconscious has the wider compass: the repressed is a part of the unconscious’ (Freud, S., 1915e, S. E. **14**, 166). The second problem was that the term ‘unconscious’ seems to cover two different categories of psychical acts, the latent and temporary unconscious, ‘which differ in no other respect from conscious ones’ and ‘processes such as the repressed ones’, which if they were to become conscious... would stand out in sharp contrast to them. (Ibid. 172)

psychical locations between which censorship was interposed.<sup>45</sup> As he noted: ‘All the acts and manifestations which I notice in myself and do not know how to link up with the rest of my mental life must be judged as if they belonged to someone else: they are to be explained by a mental life ascribed to this other person.’<sup>46</sup>

Following some trains of thought he opened up in ‘Beyond the Pleasure Principle’ (1920g), namely the consequences of a new duality of drives, Freud addressed the problems of ‘the division of the psychical into what is conscious and what is unconscious’, that ‘fundamental premise of psychoanalysis’, again in his work ‘The Ego and the Id’ (1923b)<sup>47</sup>. He underlined the problems he had with his first topography, which involved a latent unconscious (in the descriptive sense) which could be considered falsely as a ‘second consciousness’, as the paradox of an ‘unconscious consciousness’. That would give the philosophers the excuse to place both the *Pcs.* and the *Ucs.* in the ‘psychoid’ and declare the *Cs.* as the only psychical system.<sup>48</sup> In order to distance himself from the philosophers, and given the ambiguities of the descriptive terms, he will now replace the three systems *Cs.*, *Pcs.*, and *Ucs.* with a new structural conception of the *Ich*. But, he does not do this abruptly and without admitting the clinical usefulness of the three systems. He concedes that it was the dynamic concept of repression, deduced from the clinical observation of resistance, which led him to the concept of the unconscious.<sup>49</sup>

---

<sup>45</sup> Ibid., 172-174.

<sup>46</sup> Ibid., 169. Freud’s remark evokes for us the notion of the unconscious as what Lacan called ‘Other’, or ‘Otherness’.

<sup>47</sup> Freud, S., (1923b), S.E. **19**, 13.

<sup>48</sup> As he had said already, psychoanalysis differed from the descriptive psychology of consciousness, first with the dynamic and then the topographic approach... ‘...thus accepting two or three psychical systems’ (Freud, S., 1915e, S.E., **14**, 172-73).

<sup>49</sup> ‘Thus we obtain our concept of the unconscious from the theory of repression. The repressed is the prototype of the unconscious for us’ (Freud, S., 1923b, S.E. **19**, 15).

If we put together Freud's idea that repression is not there from the start, at least not repression proper (*Nachdrängung* as opposed to *Urverdrängung*), and also the contradiction of having 'in the descriptive sense two kinds of unconscious', the latent unconscious and the unconscious proper, while having 'in the dynamic sense only one', we understand the ambiguity of the term. With the distinction between a dynamic unconscious (the repressed) and a descriptive one (or two), there was the risk to discredit the concept, by inferring an unconscious consciousness, or degrees of consciousness. Freud maintained the importance of the *unconscious proper*, fundamentally inaccessible, but owing to the clinical observation, conceded that there was more to say about the organization of the whole psychological structure. He turned to *Ich*, as encompassing the entirety of the psychological structure, but he introduced differentiations, or *grades* in it.<sup>50</sup>

Now, we have one, more complex psychological structure, with at least three parts, one of which, 'the ego' (*das Ich*) does not just replace the preconscious (*Pcs.*) of the first topography or the perception/ consciousness (*Pcpt./Cs.*) system of the 'Metapsychological Supplement to the Theory of Dreams' (1917d).<sup>51</sup>

---

<sup>50</sup> Ibid., 15-17. Freud early on disassociated 'Ego' (*Ich*) and consciousness. I remind here that from a distinct defensive organization in the 'Project' (1950a[1895]), the ego had been identified with the *preconscious* in 'Letter 52' to Fliess (*December 6, 1896*). Indeed, earlier in the 'Project', Part I, [20], '*The Analysis of Dreams*', Freud had pointed out that 'consciousness does not cling to the ego, but can become an addition to any  $\psi$  processes' and that 'the primary processes were possibly not unconscious processes' (Freud, S., 1950a, S.E. 1, 340). In 'The Interpretation of Dreams' (1900a) consciousness was not a prerogative of the ego. In 'Metapsychological Supplement to the Theory of Dreams' (1917d), Freud disassociated the ego from consciousness as its energy/cathexis was transferred to the repressed in the dream process.

<sup>51</sup> In the latter, the *Pcpt./Cs.* system was ascribed the 'function of testing reality' (*Realitätsprüfung*), and 'of orienting the individual in the world by discrimination between what is internal and what is external'. Freud concluded there that 'we shall place reality-testing among the major institutions of the ego, alongside the censorships which we have come to recognize between the psychological systems.'

Now Freud realizes that although resistances too originate in the ego, the patient does not recognize them as coming from him, as analytic practice shows. Thus Freud concludes that there must be: ‘something in the ego itself which is also unconscious, which behaves like the repressed...although not repressed, and which requires special work before it can be made conscious.’<sup>52</sup>

A new modified topography must account for the new psychical structure with ramifications and cuts, showing ‘the antithesis between the entire ego (*das gesamte Ich*) and the repressed which is split off from it’.<sup>53</sup> Furthermore another instance becomes differentiated at the root of the *Ich*, an *unconscious ego*, which is not the repressed but acts as if it were - and to which Freud gives a new name: *das Es* (the id). After all, *das Ich* is not so ‘*gesamte*’, not so ‘all together’, if parts are cut off from it, like ‘the repressed’, or inaccessible, like ‘the id’. There is therefore the repressed, and the ‘unconscious ego’ (the ‘id’), on the one hand, and a ‘preconscious ego’, with the ‘perception-consciousness’ system at the top, on the other, a projection of the body’s surface, sitting like the germinal disc on top of the ovum, and an external protuberance, the ‘hearing cap of the superego’, which the ego wears ‘awry’.

In his criticism of the second topography, Lacan noted how Freud ‘let himself be carried away by Groddeck’ and his *Book of the Id* (1923). In his Seminar ‘*L’insu que sait de l’unebévue s’aile à mourre*’, Book XXIV, (1976-1977), Lacan explained in the following terms why he did not like the second topography:

---

<sup>52</sup> Freud, S., (1923b), S.E.19, 17.

<sup>53</sup> Ibid. We translate ‘*gesamt*’ as entire, whole. Strachey translates ‘*coherent*’ and this is a biased extrapolation. The id is not less coherent, less organized than the rest, which actually is rather a stitched up construction, also including an external part, the superego, and a remainder, cut-off part.

‘Those flat surfaces, the id with the big eye which is the ego, everything is laid down flat. In German the *Ich* is not the ego, it is the *I*, “where *it* was.”... For Groddeck the *id was* what what makes you alive (*ce qui vous vit*)’

With a clear reference to the organism, Groddeck’s definition is the idea of a global unity, but for Lacan ‘the *id*, the *subject* (*S*) is in dialogue, with the big Other, *S* (*A barred*), *ça*.’<sup>54</sup> It is not the organism and it is not a unity.

In ‘The Ego and the Id’ (1923b), Freud proposed a topography which, as he knows, reflects the anatomy of the brain, insofar as he places consciousness on the surface of the psychical apparatus. Thus all external sensations and feelings ‘are conscious from the start’.<sup>55</sup> But, those *internal* perceptions, those thought- processes, and displacements of mental energy, how can we come to know about them? In his first topography there was no other way in which something which was unconscious could become conscious, than by being verbalized, the visual and auditory unconscious traces of ‘things’ ( *Sachevorstellungen*) became conscious only by being linked to word-representations ( *Wortvorstellungen*) in the preconscious. He reiterates this here. The preconscious ( *Pcs.*), verbal associations act as intermediate links to bring the internal [repressed] perceptions, thoughts and feelings into consciousness.<sup>56</sup> But those internal perceptions, and sensations, which give rise to feelings of pleasure or unpleasure are more problematic, as they are not linked to visual and auditory residues, they are more immediate, ‘more elementary, more primordial’ than external

<sup>54</sup> Lacan plays here with the homophony of letters *S* (*A barred*) and *ça*. (*L’Insu que sait de l’une-bévue s’aile à mourre*’, Seminar Book XXIV (1976-1977), 11 January 1977.

<sup>55</sup> Freud, S., (1923b), S. E. **19**, 19.

<sup>56</sup> *Ibid.*, 20-21.

perceptions, and in them quantity and quality is ‘something’ that behaves like a ‘repressed impulse’: ‘It can exert a driving force without the ego noticing the compulsion. Not until there is resistance to the compulsion, a hold-up in the discharge-reaction, does the “something” at once become conscious as unpleasure.’<sup>57</sup> Internal tensions and pain, sensations and feelings only become conscious if they reach the perceptual system ( *Pcpt.*). If the way forward is barred, they do not come into being as sensations or feelings. We then speak about them as ‘unconscious feelings’, in a rather incorrect manner.

As Freud says:

. . . the difference [between ‘unconscious ideas’ and ‘unconscious feelings’] is that, whereas with *Ucs.* ideas connecting links must be created before they can be brought into the *Cs.*, with feelings which are themselves transmitted directly, this does not occur. In other words: the distinction between *Cs.* and *Pcs.* has no meaning where feelings are concerned; the *Pcs.* here drops out- and feelings are either conscious or unconscious. Even when they are attached to word presentations . . . they become so [conscious] directly.<sup>58</sup>

Now he can work out his new topography of the ego: ‘It (the ego) starts out, as we see, from the system *Pcpt.* which is its nucleus, and begins by embracing the *Pcs.* which is adjacent to the mnemonic residues. But, as we have learned, the ego is also unconscious.’<sup>59</sup>

At this stage he brings in Groddeck, who ‘is never tired of insisting that our ego behaves essentially passively in life’, and that ‘we are lived’ by unknown and uncontrollable forces’.

Groddeck’s ‘Book of the id’, ( *Das Buch vom Es* ) was also published in 1923, and as Strachey notes, ‘Groddeck himself no doubt followed the example of Nietzsche who

---

<sup>57</sup> Ibid, 22.

<sup>58</sup> Ibid, 23.

<sup>59</sup> Ibid.

habitually used this grammatical term for whatever in our nature is impersonal and so to speak, subject to natural law'.<sup>60</sup>

Freud proposes to call: '... the entity which starts out from the system *Pcpt*, and begins by being *Pcs*, the "ego" (*das Ich*)' and follows Groddeck 'in calling the other part of the mind, into which this entity extends and which behaves as though it were *Ucs.*, the "id".<sup>61</sup> The ego develops from its nucleus which is the *Pcpt.-Cs.* System:

'The ego does not completely envelop the *id*, but only does so to the extent to which the system *Pcpt* forms its [the ego's] surface, more or less as the germinal disc rests upon the ovum. The ego is not sharply separated from the id; its lower portion merges into it'.<sup>62</sup>

As for the repressed, it 'merges into the id, as well... is merely a part of it'. But the repressed is cut off 'sharply' from the ego and can only communicate with it through the id.

'We shall now look upon an individual as a psychical id (*Es*), unknown and unconscious, upon whose surface rests the ego (*Ich*), developed from its nucleus the *Pcpt* system. If we make an effort to represent this pictorially, we may add that the ego does not completely envelop the id, but only does so to the extent to which the system *Pcpt* forms the ego's surface, more or less as the germinal disc rests upon the ovum. The ego is not sharply separated from the id; its lower portion merges into it.'<sup>63</sup>

---

<sup>60</sup> Ibid.

<sup>61</sup> Ibid. Freud, S., (1923b), S.E. **19**, 24.

<sup>62</sup> Ibid.

<sup>63</sup> Ibid. As we noted above, in '*L'insu que sait de l'une-bévue s'aile à mourre*', Seminar Book XXIV (1976-77) Lacan underlined that *Es* is neither the organism nor a unity; it is *S* [homophony between letter S, the symbol of the subject, and *Es*, but in the real and in dialogue with *A*, the big Other: *S* (*A* barred) *εa*. But, there is also, he adds in the following session, 'the matter, (*l'âme-à-tiers*, the soul, -*a*-, the third), 'which is not only the real, but something with which clearly, we do not have any relation, [object *a*], this is what S (*A* barred) means' (op. cit., 17 Jan. 1977).

Freud reckons that his figure below with its lines of demarcation shows a structure which is ‘on the surface of the mental apparatus, the only ones known to us.’<sup>64</sup> The ego wears the ‘cap of hearing’, the superego, and ‘he wears it awry, on one side only’.<sup>65</sup> For Freud: ‘...the ego is that part of the id which has been modified by the direct influence of the external world through the medium of the *Pcpt.-Cs.*; in a sense it is an extension of a surface-differentiation’.<sup>66</sup>

The ego brings in the external perceptions, ‘the ego represents... reason . . . the id contains the passions’. But this is a kind of popular dichotomy with which Freud is only ‘on the average’ happy. What is more significant for him is that the ego is above all a bodily ego, a surface, ‘a place from which both internal and external perceptions may spring’.

Furthermore, it is not merely a surface, but ‘the projection of a surface’.<sup>67</sup>

---

<sup>64</sup> Freud, S., 1923b, S.E. **19**, 24.

<sup>65</sup> Freud, S., Op. cit., 25. A comparison/contrast can be made here to Lacan’s schema *L*, which I showed earlier in this thesis (Cf.: Chapter 1, p.65, and note 105). There are four terms marked on its four corners: 1) ‘*S*, the letter S, is also the subject, the analytic subject, that is to say not the subject in its totality...but in its opening up.’ 2) ‘*a*, the ego is an absolutely fundamental form for the constitution of objects... 3) ‘the ego perceives ...its fellow being in the form of the specular other. This form has a very close relation the the ego, which can be superimposed on it, and we write it as *a*’ 4) the big Other, *A*, is the wall of language’ (Lacan, J., 1954-1955, Seminar Book II 25 May 1955, op. cit., p. 243 and 244).

<sup>66</sup> Freud, S., Op. cit., . 24-25.

<sup>67</sup> Ibid., 26.



Freud's schema of the ego in the second topography:

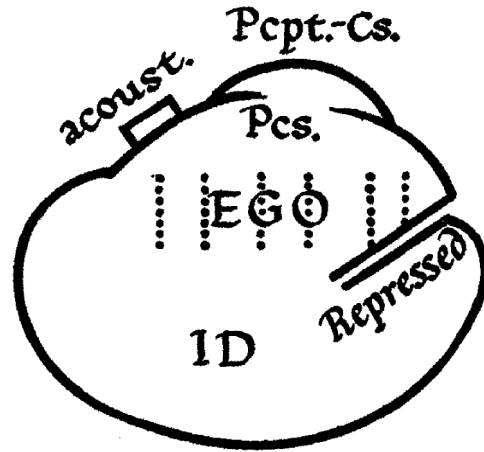

'The Ego and the Id', 1923b, S.E., 19, 24

Its modification in Freud's Lecture XXXI:

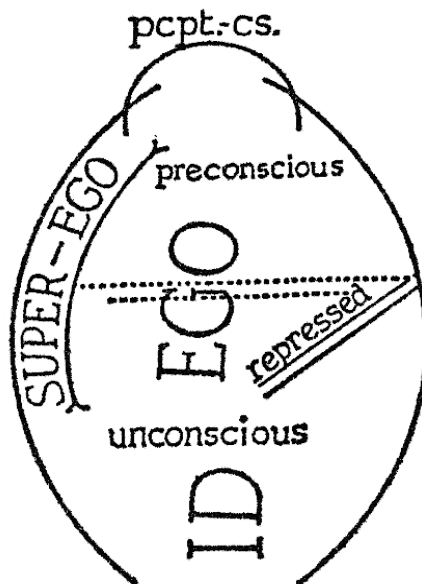

‘New Introductory Lectures’ (1933a), S.E. 22, 78.

#### **D. The superego in the second topography**

At the end of Chapter II of ‘The Ego and the Id’ (1923b) Freud turned towards another instance, which he deduced from clinical observation. This instance will be named ‘the superego’ (*das Überich*), initially another name for the ego ideal. It has a wider remit. It is not only the instance of self-criticism and conscience but also of what is approximately termed as ‘unconscious sense of guilt’, which plays ‘a decisive economic part and puts the most powerful obstacles in the way of recovery’.<sup>68</sup> Together with the unconscious ego’s (id’s) resistances or defenses it presents problems for the ego in the treatment and gives a new twist to the second topography: ‘Not only what is lowest, but also what is highest in the ego can be unconscious’ if, as Freud says, ‘we come back once more to our scale of values’.<sup>69</sup> He refers to the unconscious sense of guilt, the superego and to the unconscious resistances of the id, as his new additions.

‘The ego’ (*das Ich*) of the second topography was neither the simple reflexion of the external world in the mind, nor strictly the part of ‘the id’ (the internal), which was turned towards the external world. It was a structure in its own right, which sustained alterations and modifications as a result of its identifications to lost objects of love. Freud had devoted a chapter to define three major kinds of ‘identification’ which the ego/subject was exposed to, in his earlier work ‘Group Psychology and the Analysis of the Ego’ (1921c). The question of

---

<sup>68</sup> Ibid.

<sup>69</sup> Ibid., 27. The scale of values Freud refers to here is the division ‘conscious’ [ego] ‘unconscious’ [ego]: ‘the conscious ego is first and foremost a body-ego.’

the external object taken as the ego ideal within the structure of the ego, (or into the superego, as Freud will say later), had been discussed at length there, together with the consequences on the ego/subject itself. The external object could also come in the place of the ego, replace it, alter it, as in melancholia.

The term ‘ego ideal’ had been introduced earlier on in Freud’s paper ‘Narcissism; an Introduction’ (1914c). This is the context in which it first appeared:

‘It would not surprise us if we were to find a special psychical agency which performs the task of seeing that narcissistic satisfaction from the ego ideal is ensured and which, with this end in view, constantly watches the actual ego and measures it by that ideal’.<sup>70</sup>

Here we can note the subtle difference between the ego ideal which performs the task of overseeing narcissistic satisfaction and the ego itself which as the result of it (narcissistic satisfaction) can be qualified as ideal ego. Generally the distinction was not clear. Freud recognized the ego ideal as the agency we commonly call our ‘conscience.’ In ‘The Ego and the Id’ (1923b), it became the superego but predominantly as ‘the unconscious sense of guilt,’ which made it ‘less firmly connected with consciousness’.<sup>71</sup>

In part III of ‘The Ego and the Id’ (1923b), Freud reminded us that in his work ‘Mourning and Melancholia’ (1917e [1915]), he had explained some phenomena of pathological

---

<sup>70</sup> Freud, S., (1914c), S.E. **14**, 95.

<sup>71</sup> The super-ego or ego ideal, had been approached as an archaic form of identification, an oral incorporation or *introjection*, -the term had been proposed by Ferenczi (Freud, S., 1923b, S. E., **19**, 28). In note 2, *ibid*, Freud talks about the fluctuations of the functions he ascribed to the superego, such as ‘reality-testing’ (in ‘Group Psychology’ (1921c), S.E., **18**, 114), which he now ascribes to the ego. Another fluctuation concerned the ‘unconscious part of the ego’ which he presented earlier in ‘Beyond the Pleasure Principle’ (1920g), as its nucleus. Now he insists that *Pcpt/Cs* is the nucleus of the ego; and in his later work on ‘Humour’ (1927d), he referred to the superego as the nucleus of the ego, as Strachey adds (S.E., **18**, 28, note 2)].

mourning as resulting from the lost object of love being incorporated into the ego. Love was there replaced by identification.<sup>72</sup> Here he understands that this mechanism of identification has a wider application and forms the ‘character’ of the ego.<sup>73</sup>

Now, he calls indiscriminately superego ( *Überich*), or ego ideal ( *Ichideal*) the differentiated from the ego ‘critical agency’. Its origins lie in the oral phase when object- cathexis and identification were undistinguished. Later, as he specifies, object-cathexis will come from the id. ‘The ego . . . still feeble. . . either acquiesces in them[object-cathexes] or tries to fend them off by the process of repression’. When the former happens, ‘an alteration of the ego ensues. . . a setting up of the object inside the ego, as in melancholia’<sup>74</sup>. But, as Freud underlined ‘These identifications do not always introduce the abandoned objects in the ego’<sup>75</sup>.

Freud noticed how a person’s character was formed by successive identifications to the lost love-objects, in women especially. He turned to the earliest identifications in childhood, which were ‘general and lasting’. The first one was ‘the origin of the ego ideal’, the most important identification of an individual, with the father of his own personal prehistory:

---

<sup>72</sup> He thus distinguished the critical agency in melancholia as separate from the rest of the ego. It ‘splits off from it’ and can become diseased. The patient’s self-evaluation [the ego ideal] is low, self-accusations abound.(Mourning and Melancholia, 1917e, S.E. **14**, 247-8).

<sup>73</sup> Freud, S., (1923b), S.E. **19**, 28.

<sup>74</sup> Ibid. 29. Freud believes that such alterations of the ego, as occurred when an object is abandoned, or lost, lead generally to desexualisation, the transformation of object libido to narcissistic libido, and a kind of generalized sublimation, or they may also lead to ‘a defusion of the drives which were fused together’(ibid., 30). This is important for the clinical practice. We can have a pathology of the ego falling apart in what has been called ‘multiple personalities.’ (Ibid., 31).

<sup>75</sup> Ibid., 30. In Freud, the mechanism of *introjection* is also operative in all the other forms of identification, which have to do with an object of love lost or abandoned. He notes that this may be ‘the sole condition under which the id can give up its objects’, and ‘a method by which the ego can obtain control over the *id*’. It ‘assumes the features of the object’ so to speak, and makes itself lovable to the id, and can ‘make good the id’s losses’. In this latter case, as he underlines, narcissistic libido prevails leading to *desexualisation*, a kind of sublimation.

‘...it is a direct and immediate identification, and takes place earlier than any object}-cathexis. But the object-choices belonging to the first sexual period and relating to the father and mother seem normally to find their outcome in an identification of this kind, and would thus reinforce the primary one.’<sup>76</sup>

Identification is, however, a complex process. It is also determined by sexuality, the constitutional bisexuality of the individual and the development of the Oedipus complex. Freud endeavours to differentiate love from identification, while the easiest thing would be to say that they are one and the same thing, as Lacan noted. As Freud wrote in his ‘Group Psychology’ (1921c), there is identification which is not based on introjection of an object of love, like the primary identification to the father, but on object(sexual)-cathexis. For example the little boy’s cathexis of the mother in the Oedipus complex and rivalry with the father, is originally an attachment to the mother’s breast, a model for the anaclitic form of love. This identification to the part object (breast) can coexist side by side with the boy’s identification to the father, until the formation of the Oedipus complex. The complete Oedipus complex has ‘four trends’, two positive and two negative, and concludes with either ‘a father-identification’ or ‘a mother-identification’ at the time of its dissolution.<sup>77</sup>

Those identifications will confront the rest of the ego ‘as an ego ideal or superego.’<sup>78</sup> But the superego is not only determined by the earliest object-choices of the id, it is not only the imperative ‘you ought to be like your father’, but also the prohibition ‘you may not be like your father’. Therefore it has a double aspect, as it has been formed in order to repress the Oedipus complex.

---

<sup>76</sup> Ibid., 31.

<sup>77</sup> Ibid., 32.

<sup>78</sup> Ibid., 34.

Superego and ego ideal are not differentiated again. Its function was to repress the Oedipus complex, the child's sexual wishes towards his mother and his father. It was the obstacle erected inside. Freud underlines that it borrows its strength from the father.<sup>79</sup>

'The superego retains the character of the father, while the more powerful the Oedipus complex was and the more rapidly it succumbed to repression...the stricter will be the domination of the superego over the ego later in the form of conscience or perhaps of an unconscious sense of guilt.'<sup>80</sup>

As heir of the Oedipus complex, which it had the function to repress, the ego ideal or superego inherited also the most archaic libidinal impulses of the id. 'By setting up this ego ideal, the ego has mastered the Oedipus complex and at the same time placed itself in subjection to the id.'<sup>81</sup>

Thus, in a sense, the ego ideal or superego inherited 'the lowest part of our mental life' together with 'the highest values and morality'. This is why it has a double aspect, and it is not as easy to locate as the ego. At the same time as it functions as ideal, 'as a substitute for a longing of the father', it also carries in the form of 'conscience' the prohibitions and injunctions of the parents, teachers, and others in authority. It exercises 'moral censorship' and creates conflict with the ego.

Finally, Freud linked the formation of the ego ideal or superego to the archaic father-complex, as he described it in 'Totem and Taboo' (1912-13). Religion, morality and the

---

<sup>79</sup> Ibid.

<sup>80</sup> Ibid., 34-35.

<sup>81</sup> Ibid., 36.

social feelings were inherited phylogenetically from it. <sup>82</sup> Was it the id or the ego of the primitive man that inherited those values? But, 'perhaps to carry the differentiation between superego, ego and id so far back is wrong'. The fact is that the superego remains in communication with the id, with its early object-cathexes, and drive impulses, and this makes it 'remain to a great extent unconscious and inaccessible to the ego.'<sup>83</sup>

The conclusion reached by Freud at that stage was that the ego had been formed from successive identifications to abandoned object- cathexes of the id, abandoned objects of love, often offering itself in their place as lovable, while the superego was the outcome of the first identification to the father, a powerful identification when the ego was still weak, becoming consequently the heir of the Oedipus complex and introducing the most powerful objects of the id in the superego: it represented the parents, or more precisely their voice with as much power as Kant's 'categorical imperative.'<sup>84</sup> Freud warned about its effects on the subject, because of the sense of unconscious guilt, which 'can turn people into criminals.'<sup>85</sup> One thing is sure, that 'the super-ego . . . actually originated from the experiences that led to totemism.'<sup>86</sup>

---

<sup>82</sup> Ibid., 37. Lacan too, finds the origin of the order of the superego in the original father of 'Totem and Taboo', stressing its character of 'mythical call to pure enjoyment' (Lacan, J., *D'un Discours qui ne serait pas du semblant* 1970-71, Seminar Book 18, 16 June 1971).

<sup>83</sup> Ibid., 38-39.

<sup>84</sup> Ibid. 48, (Part V, 'The Ego and the Id', 'The Ego's dependent relations.')

<sup>85</sup> Ibid. 52. The 'negative therapeutic reaction', is one of the effects of the unconscious sense of guilt. The extraordinary harshness of the superego is fed by the destructive drive, sadism and the death drive. Freud even says that 'a pure culture of the death drive' takes hold of the ego, in melancholia in particular (ibid. 53).

<sup>86</sup> Ibid., 38. The first form of identification in Freud's '*Massenpsychologie*' (1921c) was described as the outcome of a powerful love tie with the father of the child's prehistory, and it had been modelled on the oral primitive drive, in which food incorporation and love were not differentiated. It was the mechanism which had prevailed in the incorporation of the killed totemic animal with the ensuing identification to its strength. Freud founded the origin of the ego ideal and later of the superego on that first identification.

Freud did not omit to stress that ‘the more a man checks his aggressiveness, the more severe he becomes in his ego ideal’. The super-morality of the superego can match the ‘cruelty of the id’. The superego arose from identification to the father (love for the father), but this identification is ‘in the nature of a desexualisation or even sublimation; a defusion of the drives occurs at the same time’. This is how the aggressive drive is released. It can lead to a death for the ego/subject as in melancholia,<sup>87</sup> or turn to aggressiveness towards an external object as in obsessional neurosis.

The paper ‘Das Ich und das Es’ (1923b) did not clarify the new paths it opened especially in relation to identifications. The ego ideal was totally confused with the newly introduced instance of the superego, although the latter had apparently more affinities in its clinical manifestations (melancholia, obsession) with the death drive, with hate and sadism, than the love that characterized the first identification to the father. As Lacan underlined later, the oedipus-complex of prohibition and imperative command as carried out by the superego, is not the same instance as the ego ideal lying at the origin of the first identification that to the father.

As for the ego (*Ich*) itself, it was not only the projection of a surface, but also the precipitate of the successive identifications to love objects gone, and a history of their traits. It still held the key of motor control and reality- testing, but, at the very end, it was only a differentiated part of the ‘id’, inheriting its object-cathexes together with the imperatives of the superego.

---

<sup>87</sup> Ibid., 54. ‘The fear of death in melancholia originates in that the ego gives itself up because it feels itself hated and persecuted by the superego instead of loved.’



The second topography lacks in clear definition, it needs another space, topology which we find in Lacan's Seminar *Identification* (1961-62), Book IX.<sup>88</sup>

In 1931 Freud wrote the preface to Nunberg's work which was published in 1932: 'General Theory of the Neuroses on a Psychoanalytic Basis' ( *Allgemeine Neurosenlehre auf psychoanalytische Grundlage*).<sup>89</sup> He praised the work and was inspired to further clarify his ideas. A year after its publication Freud himself published his 'New Introductory Lectures on Psychoanalysis'(1933a), where he offered a modified schema of the second topography, in which 'the superego merges into the id.'<sup>90</sup> The question of topology arises here again, especially after Lacan discovered its adequacy with the psychical structure, either as topological surfaces (intuitional forms) or as algebraic formulas or knots (set theoretic methods). Freud's topographies of lines and spheres are very special topological spaces. They could either be transformed into more general topological spaces, or replaced by new ones. The schema of Lecture XXXI can be seen as a spherical representation, with some crossings. Alternatively it can be taken to be a more general, geometrical or topological construction.<sup>91</sup>

---

<sup>88</sup> For example, in Lacan's 'cross-cap' or 'mitre'.

<sup>89</sup> Freud, S., (1932 [1931]), S.E. **21**, 258.

<sup>90</sup> Freud, S., 1933[1932]), Lecture XXXI, *The Dissection of Psychological Personality*, S.E. **22**, 57-80.

<sup>91</sup> In their respective research both Jean Michel Vappereau and Jean Gerard Bursztein proposed a series of topological transformations of Freud's schemata. Lacan was first to draw the attention on Freud's 'topologies' and talked about the 'geometry of the bag of drives' in Lecture XXXI as a closed topological surface.

### E. Freud's theory of identification

The most extensive recent study of the concept of identification in Freud was Florence's thesis consequently published as a book, 'Identification in Freud's theory' ( *L'identification dans la theorie freudienne*, 1978, Brussels). One of his first remarks was that the theory of identification was developed quite late in Freud's work, although the term was present from the very beginning. We examine this research, as it follows methodically the development of the concept in Freud, although the outcome is rather unsatisfactory, a step backwards, especially after Lacan.

He first describes what he calls Freud's empirical approach of the psychological process of identification in dreams and in hysteria. We find Freud's early views on the hysterical symptoms, and this as soon as he abandoned his theory of sexual trauma as the cause of neurosis, especially hysteria. <sup>92</sup> In one of his Letters to Fliess, <sup>93</sup> Freud underlined the importance of fantasies rather than real memories in hysteria, and described hysterical symptoms as *impulses* deriving from those fantasies which are related to the 'primal scene.' But, symptoms are finally compromises, when they come into consciousness: Fantasies serve as 'protective fictions' in paranoia, as memories in hysteria, as perverse impulses in obsession. <sup>94</sup>

---

<sup>92</sup> This theory (the 'neurotica') was given a theoretical justification by Freud in his famous 'Letter 52', December 6, 1896.

<sup>93</sup> Freud, S., Letter May 2, 1897, (Masson, J.M, 1985, 239).

<sup>94</sup> Ibid. In Draft L, enclosed with the same Letter May 2, 1897, Freud wrote: 'An immense load of guilt with self-reproaches... is made possible [in the case of a woman] by identification with these people of low morals who are so often remembered, in a sexual connection with father or brother, as worthless female material.' Identification explains even the cases of 'multiple psychic personalities' (Masson, J.M., 1985, 241-2)

Unconscious identifications were extracted from the symptoms and the symptoms were traced back to the repressed sexual fantasy in the work of analysis. We find a reminder of this early Freudian theory in Florence's thesis: 'Hysterical identification leads to symptoms which conceal sexual fantasies, involving guilt, remorse and the mechanism of repression of sexuality'.<sup>95</sup> This was indeed seen already in Freud's early writings, in his letters to Fliess, for example. But more specifically in the analysis of Dora's case (1905e), we see Freud noticing some new mental structures -he called them transferences- which involved the person of the analyst, following the same route from identifications and symptoms back to fantasies and repressed sexuality.

We find identifications not only in the scenarios of fantasies, but also in dreams. There was a particular dream which attracted Freud's attention. It was the dream of one of his patients, 'the 'butcher's wife's,' which she brought in the treatment in order, as Freud interpreted, to prove Freud's theory of the dream wrong, namely that the dream was the fulfilment of an unconscious wish. Freud noted: 'Identification is most frequently used in hysteria to express a common *sexual* element.'<sup>96</sup> That common sexual element will become the basis for Freud's third kind of identification in 'Group Psychology and the Analysis of the Ego.' (1921c)

Florence found in Lacan a distinction between 'Freud I' (1891-1913), 'Freud II' (1914-1918) and 'Freud III' (after 1918) which he used a lot. 'In Freud II', he noted, 'the concept of

---

<sup>95</sup> Florence, J. (1978), *Identification in Freudian theory*, Brussels.

<sup>96</sup> Freud S., (1900a), S.E. 4,150. As Freud specified there: 'In hysterical fantasies just as in dreams, it is enough for purposes of identification that the subject should have *thoughts* of sexual relations without their having necessarily taken place in reality' (ibid.).

identification was inserted in a different context than in the dream and in hysteria.’<sup>97</sup> In the second of the ‘Three Essays on the Theory of Sexuality’ (1905d) Freud had inserted indeed a whole section on ‘The Phases of Development of the Sexual Organization’ which he added after he wrote ‘On Narcissism, an Introduction’ (1914c).<sup>98</sup> He referred there, for the first time, to the ‘oral or cannibalistic pregenital sexual organization’. During the very early childhood oral sexual activity is inseparable from food ingestion, he said: ‘The *object* of both activities is the same. The sexual *aim* consists in the incorporation of the object –the prototype of a process which in the form of identification is later to play such an important psychological part’<sup>99</sup>.

Thus Florence does not fail to give a special place to ‘Totem and Taboo’ (1912-3) as ‘a crossroads in the theory of identification’; but, on the level of the structure, his theories are traditional object relation views, as he did not take into account those developed by Lacan in his Seminars *Identification* (1961-62) and *Crucial Problems of Psychoanalysis* (1964-65).<sup>100</sup> Florence underlined that aspect of totemic identification which commemorated the dead father and inaugurated religion, morality and the cult of the hero. Love, he said, Freud’s only metaphor for the totality of the sexual drive, replaced the pregenital drives in the phase of narcissism. It was operative in identification too. Hence Florence’s verdict concerning ‘Freud

---

<sup>97</sup> Freud had talked about identification in hysteria in part IV of his Interpretation of Dreams (1900a), S.E., 4, 149-150: ‘Identification is a very important factor in the mechanism of hysterical symptoms.’ He underlined that it was unconscious: ‘an unconscious drawing of an inference . . . Thus identification is not simple imitation but assimilation on the basis of a similar aetiological pretension; it expresses a resemblance and is derived from a common element which remains in the unconscious.’

<sup>98</sup> Florence, J., 197. Cf. Freud, S., (1905d), S.E. 7, [6] pp 197-99. Freud had already introduced the sadistic-anal pregenital organization in ‘The Predisposition to Obsessional Neurosis’ (1913i), as Strachey notes (ibid. 198, note 2).

<sup>99</sup> Ibid. For remnants of this phase in adults, Freud referred to Abraham’s paper ‘The First Pregenital Stage of the Libido’ (1916), in a note he added here in 1920 (ibid).

<sup>100</sup> Lacan, J., Seminar *Problèmes Cruciaux de la Psychanalyse* (1964-65), unpublished.

II' and 'Freud III' was: 'All identification is narcissistic in Freud, identification to the symptom and identification to desire, because it all now stems from the drives and libido.'<sup>101</sup>  
 There was only one exception.

Freud's theory of identification, during the middle period of his work, was based on the mechanism of incorporation, predominant in the oral cannibalistic phase, for which Ferenczi had coined the term 'introjection'. In the process of pathological mourning, as Freud developed in *Mourning and Melancholia* (1917e), the object of love, after it was abandoned, was introduced in the ego, and love was replaced by identification. But, was it a narcissistic identification? Florence's reading of Freudian meta-psychology on the basis of the theory of narcissism leads him to a very reductive view of the Freudian theory of identification. To say that Freud himself 'recognised identification as a destiny of the narcissistic libido'<sup>102</sup> was an extrapolation, which only concerned *narcissistic affections*, such as melancholia and paraphrenia (schizophrenia): The whole mechanism there had been described by Freud in 'Mourning and Melancholia' (1917e):

'An object-choice, an attachment of the libido to a particular person, had at one time existed; then, owing to a real slight or disappointment coming from this loved person, the object-relationship was shattered...The object-cathexis proved to have little power of resistance and was brought to an end. But the free libido was not displaced onto another object; it was withdrawn into the ego. There however it was not employed in any unspecified way but served to establish an *identification* of the ego with the abandoned object. Thus the shadow of the object fell upon the ego...In this way an object-loss was transformed into an ego-loss and the conflict between the ego and the loved person into a cleavage between the critical activity of the ego and the ego as altered by identification.'<sup>103</sup>

---

<sup>101</sup> 'Identification is fundamentally narcissistic. It is the work of incorporation by the ego, the transformation of the libidinal object-cathexis to ego-cathexis. The regression itself is narcissistic; it serves the interests of the ego. It ensures its preservation.' Florence, J., (1978), op. cit., 154.

<sup>102</sup> Florence, J., op. cit., 66.

<sup>103</sup> Freud, S., (1917e), S.E. **14**, 249.

Freud had concluded that ‘this substitution of identification for object-love was an important mechanism in the narcissistic affections.’<sup>104</sup> He conceded that regression from one type of object-choice to narcissism occurred in cases such as Landauer’s catatonia or cases of melancholia although, he said, this was not completely confirmed. He drew comparisons between the archaic form of identification in the oral cannibalistic stage with the incorporation of food, agreeing in that with Abraham’s theory of the connection between refusal of nourishment and melancholia.<sup>105</sup> However, he underlined the limits between identification and regression to narcissism in the transference neuroses and especially in hysteria. Clinical observation showed that *in the transference neuroses* the object-cathexis was not abandoned, although, as Freud admitted, it was also true that identification in them, especially in hysteria, was ‘the expression of having something in common’ and ‘may signify love’. He concluded: ‘Narcissistic identification is the older of the two and it paves the way to an understanding of hysterical identification . . .’<sup>106</sup>

But, in ‘Group Psychology and the Analysis of the Ego’ (1921c), Freud distinguished between social identification and narcissistic identification:

‘The contrast between social and narcissistic – Bleuler [1912] would perhaps call them ‘autistic’-mental acts therefore falls wholly within the domain of individual psychology, and is not well calculated to differentiate it from a social or group psychology.’<sup>107</sup>

---

<sup>104</sup> And ‘the love relation need not be given up’ (Ibid). As an example of recovery through the use of that mechanism, Freud cited Karl Landauer’s 1914 study of a ‘Spontaneous Healing of Catatonia’ in a case of schizophrenia.

<sup>105</sup> Abraham’s paper ‘Notes on the Psychoanalytical Investigation and Treatment of Manic-depressive Insanity and Allied Conditions’ was published in 1912; *Selected Papers on Psychoanalysis*, Hogarth Press, London 1927.

<sup>106</sup> Freud, S., (1917e), S.E. **14**, 250.

<sup>107</sup> Freud, S., (1921c), S.E. **18**, 69.

In 'Group Psychology and the Analysis of the Ego' ( *Massenpsychologie und Ich-Analyse*, 1921c), Freud referred to 'Totem and Taboo' (1913-1914), rather than to 'On Narcissism; an Introduction' (1914c) or even 'Beyond the Pleasure Principle' (1920g)<sup>108</sup>. As Freud said there, other mechanisms for emotional ties besides the ones of love must be taken into account. Actually, 'we learn from psychoanalysis that there do exist.' There were special cases of identification which reminded of group identifications, such as in the church and the army, insufficiently known and hard to describe' processes, which he promised to investigate, although they would keep him for some time away from the subject of 'group psychology'. He did so in chapters VII, VIII, and XI of that work. In Chapter VII, Freud proposed at least three different modes of identification, all of which were outside the realm of narcissism although not indifferent to it, except for the third kind.<sup>109</sup>

Chapter VII of *Massenpsychologie* called 'Identification' is the only single development of the concept in Freud's work. It is a concise description of the structure of three forms of identification. Other kinds of identification also existed and briefly mentioned, especially the particularities of identification in melancholia, homosexuality and psychosis and the problem of empathy.

---

<sup>108</sup> Florence suggested that 'Group Psychology' (1921c) was a regressive step in relation to the new duality of the drives, Freud introduced in 'Beyond the Pleasure Principle' (1920g). The 'death drive', he argued, should have had effects on Freud's identification theory in accordance with 'the masochistic tendencies of the ego' whose existence Freud had acknowledged in that work. He only found one example in the Wolf Man case (1918b [1914]), an 'identification to the traumatic signifier', as he wrote influenced by Lacan, the wolf's gaze in the dream. In 'Group Psychology', Freud noticed the narcissism of small differences in group phenomena (Freud, S., 1921c, S.E. **18**, 102).

<sup>109</sup> Freud demonstrated the value of his libido theory when he extended it to the ego as an object. With the notion of ego-libido and the introduction of narcissism, he extended his theory from the sexual aetiology of the transference neuroses to the narcissistic aetiology of the narcissistic neuroses, the psychoses, the war neuroses and the traumatic neuroses (Cf.: Freud, S., 'Introduction to Psychoanalysis and the War-Neuroses', 1919, S.E., **17**, 209-210).

In Chapter VIII the two libidinal situations, being in love and hypnosis and the role of the external object in them lead to a new structural arrangement within the ego. In ‘being in love’, the sexual object comes in the place of the ego, replaces it, and becomes *overvalued* and *idealised*:

‘We see that the object is being treated in the same way as our own ego, so that when we are in love a considerable amount of narcissistic libido overflows onto the object. It is even obvious in many forms of love-choice that the object serves as a substitute for some unattained ego ideal of our own.’<sup>110</sup>

In that sense ‘being in love’ is a way of satisfying our own narcissism. We love the object for all the perfections we had wished to reach for our own ego, and this was something that Freud had already said in his paper ‘On Narcissism’ (1914c).<sup>111</sup>

But, in the case of an intensified sexual overvaluation, the impulsions of sexual satisfaction are pushed into the background and... ‘the ego becomes more and more unassuming and modest, and the object more and more sublime and precious . . . the object has so to speak consumed the ego.’<sup>112</sup> The critical function recedes and narcissism undergoes a limitation because, as Freud put it: ‘the object has been put in the place of the ego ideal’.<sup>113</sup>

Wanting to determine the differences and relations between those extreme states of ‘being in love’ (a situation he compares to the hypnotic phenomena) and ‘identification’, Freud underlined that in the former (being in love), ‘the ego is impoverished, has surrendered itself

---

<sup>110</sup> Freud S., 1921c, S.E. **18**, 112.

<sup>111</sup> A similar line of development first appeared in the paper ‘On Narcissism; an Introduction’ (1914c) at the beginning of part III.

<sup>112</sup> Freud S., 1921c, S.E. **18**, 113..

<sup>113</sup> Ibid. Lacan would call this a ‘rising of object *a* to the dignity of the Thing’.



to the object, has substituted the object for its own most important constituent'; in the latter (identification), the ego introjected the object into itself and is enriched by that 'introjection' (Ferenczi's term of 1909):

'... in the case of identification the object has been lost or given up; it is then set up again inside the ego, and the ego makes a partial alteration in itself after the model of the lost object. In the other case the object is retained and there is a hyper-cathexis of it by the ego at the ego's expense.'<sup>114</sup>

But then the differences are blurred again between love and identification. This is why, when Freud tried to answer the question if there was no identification, in the case the object had not been lost, and therefore there was no real alternative between love and identification, he rephrased the differentiation: 'namely whether the object has been put in the place of the ego or of the ego ideal.'<sup>115</sup>

The situation of hypnosis with its similarities and/or differences with being in love and excluding the directly sexual trends... 'contains an element of paralysis derived from the relation between someone with superior power and someone who is without power and helpless.'<sup>116</sup> It was another case of the libidinal constitution of groups, which derived either from love or from hypnosis. Freud then articulated his formula for the libidinal constitution of groups:

---

<sup>114</sup> Ibid., 114.

<sup>115</sup> Ibid.

<sup>116</sup> Ibid., 115.

‘A primary group of this kind (a group with a leader) is a number of individuals who have put one and the same object in the place of their ego ideal and have consequently identified themselves with one another in their ego.’

He also gave its graphic representation:

Schema of the libidinal structure of the ego in ‘being in love’, hypnosis and groups.

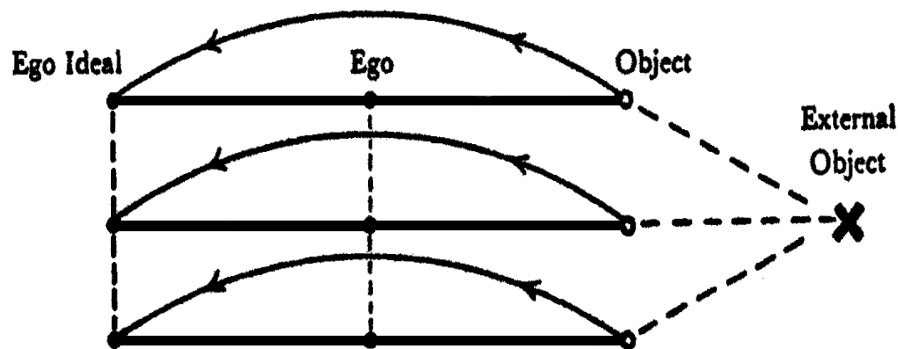

Freud S., (1921c), S.E. **18**, 116

In the last chapter (XI) of ‘Group Psychology’ (1921c) following the study of the libidinal structure of groups, Freud returned to the mechanisms of individual identification to the external object and considered the cases of its pathology. Melancholia and the recurrent cycles of mania were the pathological clinical manifestations of an identification either to the unworthy object of love (condemned by the ego ideal) or to the ego ideal:

‘So far we only understand those cases in which the object is given up because it has shown itself unworthy of love. It is then set up again inside the ego, by means of identification, and severely condemned by the ego ideal.’<sup>117</sup>

<sup>117</sup> ‘A differentiating grade in the ego.’ (Freud S., 1921c, S. E., **18**, 133)

In Chapter III of 'The Ego and the Id' (1923b) , Freud developed 'the superego or ego-ideal' but not as exactly the same. He put more and more emphasis on the superego as an unconscious identification. The superego was less firmly connected with consciousness. This distinction explained the rift in the ego. As the field of the ego's unconscious identifications extended to the superego, and to the abandoned sexual objects (of the id, in fact), we end with the pathological alterations of the ego as a whole: 'an alteration of the ego' (*Ichveränderung*) which could be described as a setting up of the object inside the ego, as in melancholia, and another identification to the critical agency, the superego. Thus the ego could be split between the unconscious identifications to abandoned object-cathexes and the superego. The function of the superego was to observe, judge and punish accordingly the ego in its relations to the ego ideal, while the latter became a function of the superego. It seemed that the duality of the drives Freud had introduced in 'Beyond the Pleasure Principle' (1920g), was leading him now towards the functions either of desexualisation or of sublimation assumed respectively by the superego and the ego ideal, and could result in the defusion of the drives in psychosis. <sup>118</sup>

---

<sup>118</sup> Freud S., 1923b, S.E.19, 28-30. The term 'defusion of drives' first appeared in a short encyclopaedia article which Freud wrote for the 'Dictionary of Sexual Science' (*Handwörterbuch der Sexualwissenschaft*) published in 1923. It was written in the summer 1922, just before 'The Ego and the Id'. We find it as 'The Theory of the Libido', is in S.E. 18, 255-259.

### **E. Freud's three kinds of identification as found in 'Group Psychology'(1921c)**

Florence noted the importance of Freud's 'Totem and Taboo' (1912-13) in the construction of the Freudian theory of identification, but approached it as part of the theory of narcissism

<sup>119</sup>. Freud had given a particular importance to the ritual killing of the totem animal,

followed by the cannibalistic meal, in the constitution of the clan:

‘ the clan is celebrating the ceremonial occasion by the cruel slaughter of its totem animal and is devouring it raw . . . The clansmen are there, dressed in the likeness of the totem and imitating it in sound and movement, as though they are seeking to stress their identity with it. Each man is conscious that he is performing an act forbidden to the individual and justifiable only through the participation of the whole clan; nor may anyone absent himself from the killing and the meal. When the deed is done, the slaughtered animal is lamented and bewailed. The mourning is obligatory, imposed by the dread of a threatened retribution.’ <sup>120</sup>

In 'Totem and Taboo' (1912-3) Freud brought together the anthropologically studied ritual of the totemic meal and Darwin's theory of the primal horde to construct his psychoanalytic interpretation about the origins of religion, morality, and the first social organization of man as deriving from the killing of the father of the primal horde.

As Freud underlined, in Darwin's primal horde 'all that we find is a violent and jealous father who keeps all the females for himself and drives away his sons as they grow up', we do not find totemism. This earliest state of society was never an object of observation. The earliest state of human society we know was 'a band of brothers having equal rights and subject to the restrictions of the totemic system . . .' Can we assume that the human social

---

<sup>119</sup> Cf.: This thesis, Chapter 3, section D., p. 190.

<sup>120</sup> Freud, S., (1912-13), S.E. **13**, 140. Freud consulted Robertson Smith's work, 'Lectures on the Religion of the Semites'(1894) for his theory of the totemic meal.

organization derived from a combination of both theories and that the second form derived from the first mythical one? It is plausible:

‘One day the brothers who had been driven out came together, killed and devoured the father and so made an end of the patriarchal horde . . . The violent primitive father had doubtless been the feared and envied model of each one of the company of brothers: and in the act of devouring him they accomplished their identification with him, and each one of them acquired a portion of his strength. The totem meal, which is perhaps mankind’s earliest festival, would thus be a repetition and commemoration of the memorable and criminal deed which was the beginning of so many things, of social organization, of moral restrictions and of religion.’<sup>121</sup>

‘Totemism’, as Florence pointed out, ‘is the question of the ideal.’<sup>122</sup>

What we know as Freud’s first form of identification<sup>123</sup> is very close to Freud’s interpretation of the totemic meal. The first identification, the ‘earliest expression of an emotional tie with another person’ taking place before the choice of any object, has an archaic form.

‘It behaves like a derivative of the first *oral* phase of the organization of the libido, in which the object that we long for and prize is assimilated by eating and is annihilated as such. The cannibal as we know has remained at this standpoint; he has a devouring affection for his enemies and only devours people of whom he is fond’<sup>124</sup>

---

<sup>121</sup> Freud, S., Ibid.141-2.

<sup>122</sup> Florence J.,(1978) however will reduce the question of the ego ideal to the formation of the ego’s character as narcissistic identification. (op. cit., 206).

<sup>123</sup> Freud, S., (1921c), S. E. **18**, 105.

<sup>124</sup> Ibid. A the end of Chapter VII of that work Freud referred to the ‘ego ideal’ as we know it from melancholia,: ‘Some agency develops in our ego which may cut itself off from the rest of the ego and come into conflict with it. We have called it “the ego ideal” and by way of functions we have ascribed to it self-observation, the moral conscience, the censorship of dreams and the chief influence in repression... it is the heir to the original narcissism,..., it gradually gathers up from the influences of the environment the demands which that environment makes upon the ego and which the ego cannot always rise to.’ (ibid., 109-10).

The first identification precedes the Oedipus complex and prepares the way to it. Freud acknowledged it as the ego ideal.<sup>125</sup>

Freud described the first identification as a product ( *Abkömmling*) of the oral phase of the organization of libido and as ambivalent from the start. In order to be like the ancestor the cannibal devours the totemic animal which represents him. Love and devouring go together in this first identification. If confusion is created therefore it is because the levels of incorporation as real, imaginary and symbolic are not distinguished before Lacan.

In his Seminar ‘Anxiety’ (Book X, 1962-63), Lacan distinguished them again with the help of the dialectics of having and being. In taking the father as one’s ego ideal, what prevails is being the father, a symbolic identification, a formation of the subject. Taking the father as love-object is an object-choice, for the little boy, and an imaginary identification to the phallus. Freud had differentiated in those two identifications an ego-subject and an ego-object identification.

‘In the first case one’s father is what one would like to *be*, and in the second he is what one would like to *have*. The distinction that is depends upon whether the tie attaches to the subject (*Ich-subjekt*) or to the object of the ego (*Ich-objekt*),<sup>126</sup>

In the ‘Ego and the Id’ (1923b) Freud expressed a slightly different view: ‘At the very beginning, in the individual’s primitive oral phase, object cathexis and identification are no doubt indistinguishable from each other.’<sup>127</sup>

---

<sup>125</sup> Freud, S., (1923b), S.E. **19**, 31: ‘. . . the effects of the first identifications made in earliest childhood will be general and lasting. This leads us back to the origin of the ego ideal; for behind it there lies hidden an individual’s first and most important identification, his identification with the father in his own personal prehistory’.

<sup>126</sup> This is one of the four occurrences of the term ‘subject’ (*Subjekt*) in Freud. (Freud, S., 1921b, S.E. **18**, 106).

A second form of identification was extracted from the hysterical symptom. Freud not only cited as an example the little girl who ‘develops the same painful symptom as her mother... the same tormenting cough,’ but also, as in Dora’s case, ‘her sympathetic imitation of her father’s cough’. Both showed the oedipal structure of the neurotic symptom.<sup>128</sup> Freud described that state of things as ‘identification instead of object-choice, object choice has regressed to identification.’<sup>129</sup> As Freud had already noted in a Letter to Fliess (Draft L, 2 May, 1897) complex identifications in hysteric symptoms were usually generating guilt and were linked to something sexual and repressed.<sup>130</sup> These hysterical symptoms due to repression had a structure linking them to the Oedipus complex. In these identifications, he said, ‘the ego sometimes copies the person who is not loved and sometimes the person who is loved’. But the most striking characteristic is that ‘in both cases the identification is a partial and extremely limited one (*beschränkte*), and only borrows a single trait (*einen einzigen Zug*) from the person who is its object.’<sup>131</sup>

Freud finds a third case of symptom formation, ‘in which identification leaves entirely out of account any object-relation to the person who is being copied.’<sup>132</sup> The example is well known: ‘One of the girls in a boarding school has had a letter from someone with whom she is secretly in love which arouses her jealousy, and she reacts to it with a fit of hysterics; then some of her friends who know about it will catch the fit, as we say, by mental infection. The

---

<sup>127</sup> Freud, S., (1923b), S.E. **19**, 29.

<sup>128</sup> Freud, S., (1921c), S.E. **18**, 106.

<sup>129</sup> *Ibid.*, 107.

<sup>130</sup> Mason, J.M., (1985), p. 241

<sup>131</sup> Freud, S., (1921c), S.E. **18**, 107. Lacan singled out Freud’s second form of identification to *einen einzigen Zug*’ as the matrix of all identification (instead of narcissism, therefore). He also called it ‘identification to the unary trait’ a term borrowed from the language of sets.

<sup>132</sup> Freud, S., *op. cit.*

mechanism is that of identification based upon the possibility or the desire of putting oneself in the same situation.’<sup>133</sup> This identification to desire ‘by means of the symptom’, is not the result of sympathy, ‘on the contrary, the sympathy only arises out of identification’, as Freud underlines. It is also noticed in cases where there is much less proximity between those affected. This kind of identification will be at the origin of an emotional tie between those affected, something which did not exist before, and which, as Freud says, must be happening in a group situation too. At first it is identification between two egos marking a ‘coincidence which has to be kept repressed’.<sup>134</sup> Then it can extend to a group. It is the way the emotional ties between the members of a group are established. They all share a common emotional quality, and this lies in the nature of the tie with the leader.

Freud summarized thus the three sources of identification:

‘First, identification is the original form of an emotional tie with an object; secondly, in a regressive way, it becomes a substitute for a libidinal object-tie . . . by means of introjection of the object into the ego; and thirdly it may arise with any new perception of a common quality shared with some other person who is not an object of the sexual instinct.’<sup>135</sup>

Other aspects of identification are not tackled in this text, as he warns us, empathy (*Einführung*) for example, ‘which plays the largest part in our understanding of what is inherently foreign to our ego (*Ichfremde*) in other people.’<sup>136</sup> Psychoanalytic research has already attacked some of the problems of identification in psychosis and Freud will refer here to melancholia and the delusions of observation · The question of identification in male homosexuality has also been the subject of Freud’s study previously, in the Leonardo Da

---

<sup>133</sup> Ibid.

<sup>134</sup> Ibid.

<sup>135</sup> Freud, S., (1921c), S.E. **18**, 108.

<sup>136</sup> Ibid.



Vinci case (1910c). In homosexuality, identification will determine the subject's sexual choice. 'A striking thing about this identification is its ample scale; it remoulds the ego in one of its important features, in its sexual character upon the model of what has hitherto been the object.'<sup>137</sup> The object itself is renounced (the mother), although the love for that object may be preserved in the unconscious. This is an identification which 'is not a novelty to us', the object has been introduced into the ego.

The study of 'Melancholia' (1917e), gave Freud the opportunity of a conceptual elaboration of the operations of 'self-depreciation, and relentless self-criticism' after the loss of a loved object. Melancholia was different from the normal process of mourning and from 'pathological mourning.' The effects of identification to the lost object combined 'with bitter self-reproaches' were so striking that now Freud talks of a 'division' in the ego which seems more like a rift:

But these melancholias also show us something else, which may be of importance for our later discussions. They show us the ego divided, fallen apart into two pieces, one of which rages against the second. This second piece is the one which has been altered by introjection and which contains the lost object. But the piece which behaves so cruelly is not unknown to us either. It comprises the conscience, a critical agency within the ego.<sup>138</sup>

Freud had already found this agency developing in the ego, cutting itself off from the rest of the ego and entering in conflict with it. It had the functions of 'self-observation, the moral conscience, the censorship of dreams, and the chief influence in repression'. It was the ego

---

<sup>137</sup> Ibid., 109. It is closer, as Freud notes, to something we can observe in small children: a case was published in the *Internationale Zeitschrift für Psychoanalyse* of a small child who, 'unhappy over the loss of a kitten declared straight out that he himself was the kitten and accordingly crawled about on all fours . . . etc'. This is also transformation of someone's *Ich* according to the model (*Vorbild*) of an object which was object of love until then. It is almost a transitory psychosis.

<sup>138</sup> Ibid.

ideal.<sup>139</sup> This agency is further noticed in delusions of observation and disintegrates into the voices in psychosis (the influence of superior powers, says Freud, and above all of parents).

### **G. Towards another Freud?**

In 'The Ego and the Id' (1923b) Freud put forward the idea of an 'unconscious part of the ego', of which only the effects can be noticed, but which remains inaccessible without being neither repressed - although acting as if it was repressed - nor latent, as the preconscious was. It is something that causes resistances from the official ego and defence. Freud differentiated that part as id, *das Es*. Until then, as he noted, what psychoanalysis meant by the unconscious was only the repressed.

In his 'New Introductory Lectures' (1933a), Freud talked almost exclusively of the superego, which seemed to acquire a distinct function:

'The superego seems to have made a one-sided choice and to have picked out only the parents' strictness and severity, their prohibiting and punitive function, whereas their loving care seems not to have been taken over and maintained.'<sup>140</sup>

Freud reiterated here that the superego was the heir of the Oedipus complex, 'the heir of that emotional attachment'. As the child had to 'renounce the intense object-cathexes', it was compensated by a strong identification to the parents, although the superego later became

---

<sup>139</sup> Ibid., 110.

<sup>140</sup> Freud S., (1933a), Lecture XXXI, S.E. 22, 62. One more important function was added to the superego there by Freud: 'It is also the vehicle of the ego ideal by which the ego measures itself, and whose demand of ever greater perfection it strives to fulfill.' Ibid. 64-65.

more impersonal<sup>141</sup>. Freud attributed its character of ‘relentless severity’ to ‘the transformations of the drive during the formation of the superego.’<sup>142</sup> We find in Lecture XXXII(1933a) a paragraph concerning that transformation, as aggressiveness coming from the external world and internalized, which explained the superego’s ‘unconscious need for punishment’ and made it synonymous with the ‘the unconscious sense of guilt’, ‘a prolongation of our conscience into the unconscious.’<sup>143</sup> Freud’s concept of the defusion of the drives which he discussed earlier, in ‘The Ego and the Id’ (1923b),<sup>144</sup> was also related to the formation of the superego.

From that moment onwards Freud had differentiated the superego as an imperative, whose strength could be compared to Kant’s imperative, an unconscious command, ‘you ought to be like this’ (like your father) and a prohibition ‘you may not be like this’ (your father). The ego ideal was, on the other hand, ‘a substitute for a longing for the father’. Both had to do with the father but in a different way; In ‘Totem and Taboo’ (1912-13), it was the incorporation of the qualities of the primal father, (testimony of love with guilt for his destruction) which formed the original sense of religion, morality and the ego ideal. In ‘The Ego and the Id’ (1923b), it was the superego which originated ‘from the experiences that led to totemism’.<sup>145</sup>

---

<sup>141</sup> Ibid., 64.

<sup>142</sup> Ibid., 62.

<sup>143</sup> Freud, S., (1933a), S.E. **22**, 109.

<sup>144</sup> Freud, S., (1923b), S.E. **19**, 41-42. ‘Once we have admitted the idea of a fusion of the two classes of drives with each other, the possibility of a –more or less complete- “defusion” of them forces itself upon us’

<sup>145</sup> Ibid., 38. Freud’s theory or myth of early human society in ‘Totem and Taboo’(1912-13) was inspired by the studies of totemism in the work of J. G. Frazer and the totemic meal in William Robertson’s. In ‘An Outline of Psychoanalysis’ (1940a[1938]) Freud placed the superego between the internal and the external world, representing the demands of both.

Freud's instance of the ego ideal had initially encompassed the critical agency, or 'our conscience', the main function of which was self-reproach, and self-observation. It manifested as depersonalisation in schizophrenia and as the delusion of being watched in paranoia. In the second topography, Freud made the superego an agency punishing the ego for not conforming to its ideal (ego ideal). The superego acquired extreme severity and cruelty in conditions such as melancholia.

'The superego applies the strictest moral standard to the helpless ego which is at its mercy; in general it represents the claims of morality, and we realize all at once that our moral sense of guilt is the expression of the tension between the ego and the superego.'<sup>146</sup>

A 'manic ego' takes the upper hand periodically in the bipolar condition of manic-depression, when the criticism by the superego gradually weakens.

Freud's 'New Introductory Lectures' (1933a) followed the publication of Hermann Nunberg's 'General Theory of the Neuroses on a Psychoanalytic Basis' (1932), which Freud had prefaced with praise (1932b[1931]).<sup>147</sup> Freud, however, did not share the same views with Nunberg concerning the ego. Chapter V of Nunberg's work bearing the title 'the psychology of the ego' contained a long exposition of the psychological structure. Nunberg differentiated between the ideal ego, on the one hand, which Freud will call 'the manic ego' in Lecture XXXI, and the superego or ego ideal, on the other. Formed during primary

---

<sup>146</sup> Freud, S., 1933[1932], *New Introductory Lectures of Psychoanalysis*, S.E. **22**, 61

<sup>147</sup> *Allgemeine Neurosenlehre auf psychoanalytischen Grundlage* was first published in German in 1932. The Preface by S. Freud, (1932[1931]) was published in S.E. **21**, 258. For the English translation see Strachey, L., (1955), 'Principles of Psychoanalysis', London.

narcissism, 'the as yet unorganized ego which feels as one with the id, corresponds to an ideal condition and is therefore called the ideal ego.'<sup>148</sup>

'The ideal ego pursues the pleasure principle. It is a pleasure ego. Everything which gives pleasure is turned towards the ego and taken into it; everything unpleasant is rejected and projected and attributed to the hostile-seeming outer world.'<sup>149</sup>

Nunberg, however, took a distinctly different orientation from Freud, as he became more and more influenced by the work of Hartmann. Adaptation to reality became an important function of the ego, which he called the 'thinking organ', even if some of the thinking acts were recognized as unconscious. Self-observation by the ego was partly transformed into attention to inform the reality of perception and partly remained in its original form. From there it formed another part which we call our 'conscience', our superego. Nunberg argued about the strong relation between the sensory organs and superego:

'The origin of the controlling faculty of conscience is herewith disclosed. It develops as a result of the incorporation into the ego of the authorities of very early childhood...It develops from the absorption into the ego of stimuli from the external world with the aid of the sensory organs, through seeing, hearing and so on'.<sup>150</sup>

It inserted itself between the ego and the id as 'society's inner representative', broke the harmony between them, and became a rigid law code with harsh traits.<sup>151</sup> The notion of absorption showed the link of the superego with food.

---

<sup>148</sup> Ibid., 126.

<sup>149</sup> Ibid., 127.

<sup>150</sup> Ibid. 140.

<sup>151</sup> Ibid. 141.

A libidinal transformation took place also during the formation of the superego. As the father was incorporated into the ego, libido was withdrawn from him. Libido which was predominant in the early narcissism withdrew and a ‘defusion’ of the drives followed.<sup>152</sup>

As Nunberg wrote: ‘If the ego ideal and the superego are representatives of the outer world in the ego’, and ‘if furthermore the ego ideal is an image of the loved objects in the ego, and the superego is an image of the hated and feared objects, why is it that the two concepts are confused?’ There was a historical reason for that, he answered:

‘When Freud first formulated the concept of the ego ideal he stressed its libidinal aspect, perhaps keeping in mind also the tender ideal love surrounding it. Later he placed more stress on the sadistic side, the severe, demanding one, “standing above” the ego – the superego.’<sup>153</sup>

Freud’s stress moved from the libidinal aspect which he stressed when developing the ego ideal, to the sadistic side, the severe, demanding one . . . the superego.’<sup>154</sup>

Thus Nunberg came to talk of the ego ideal as containing ‘more maternal libido’ and the superego as containing ‘more paternal libido,’ while Freud had avoided to personify the two instances. Love and hatred certainly played their role in the formation of social ideals. Freud’s work had argued exactly that. But, depending which one prevails, life will be

---

<sup>152</sup> Ibid. 141-2.

<sup>153</sup> Ibid. 146.

<sup>154</sup> Ibid.

different for the individual. However, Nunberg recognized an element of libido, love, in the superego too, as 'it also derives from the father'.<sup>155</sup>

In the years which followed 'The Ego and the Id' (1923b), Freud brought new elements, new structural ideas. He got involved 'in new ways of looking at things and new ways of arranging them rather than new discoveries', as he said. He brought forward a new mechanism of defence in his paper 'Negation' (1925h, *Die Verneinung*) and later linked negation or disavowal with perversion but also extended to all the neuroses. In 'Inhibitions, Symptoms and Anxiety' (1926 d), developed a second theory on anxiety, and in 'Fetishism' (1927e), and the posthumously published paper 'The Splitting of the Ego in the Process of Defence' (1940e [1938]) he showed a rift in the ego, caused by the new mechanism of defence against castration anxiety. It seems that Freud moved in new directions following the definition of the superego. Important consequences for the clinical practice and especially the technique of psychoanalysis relied on those 'metapsychological' rearrangements. There was a convergence of those many 'new ways'. For example, the amplification of the role of the superego (and of the ego ideal) had both structural and clinical consequences.<sup>156</sup> In 'Lecture XXXI' (1933a) the superego had taken over much of what previously was part and parcel of the ego's role, such as repression and anxiety. But towards the end of his work, in 'An Outline of Psychoanalysis (1940a[1938]) Freud returned to his original concerns of the ego as the central piece of the psychical structure, the main concern of the treatment, but then it was obvious that this ego as well as the superego and the id, were one structure,

---

<sup>155</sup> Ibid., 147. Nunberg discussed very little primary masochism, but insisted on the influence of sadism and the aggressive drive in the formation of the superego.

<sup>156</sup> Freud S., (1933a), S.E. **22**, 58-59: As the observing agency, the superego can split the ego 'along the lines of cleavage', which were already marked. Freud uses the metaphor of the crystal falling on the floor.

unconscious for the greater part.<sup>157</sup> The ego (*Ich*) became more like the psychoanalytic subject in that work, in which Freud gave his testament of the general theory of psychoanalysis, and his views on the aims of the psychoanalytic treatment. One of them was to restore the autonomy of the ego (the subject) in relation to the superego and to the id.

In 'The ego and the id' (1923b), Freud had indicated that the ego could be altered by identification, become a substitute for the erotic love-object. This could lead to the curious effect of 'desexualization', as the ego drained the id from its libido. Curiously he likened that process to a kind of 'sublimation'.<sup>158</sup> We may be sceptical about the assimilation of desexualisation and sublimation and wish to follow further investigations to find out 'if sublimation takes place through the mediation of the ego.'<sup>159</sup> But, the process of secondary narcissism (psychosis) resulted also in 'desexualisation', therefore desexualisation seemed to imply 'an amplification of the theory of narcissism'.<sup>160</sup>

The conflict between *Eros* and *Thanatos* seemed likely to end in favor of the death drive, a desexualized ego in generalized psychosis. How could Freud maintain that duality of the drives, as the ego managed to drain all libido from the id, leaving it to the silence of the drives?

---

<sup>157</sup> Freud, S., 1940a [1938], S.E. **23**, 162: 'conscious processes are on the periphery of the ego, everything else in the ego is unconscious'.

<sup>158</sup> Freud, S., (1933a), S.E. **22**, 64-65. We find in this lecture a lot of elements reminiscent of Nunberg's developments.

<sup>159</sup> Freud, S., (1923b), S.E. **19**, 45.

<sup>160</sup> *Ibid.*, 46: 'By thus getting hold of the libido from object-cathexes, setting itself up as sole love-object and desexualizing or sublimating the libido of the id, the ego is working in opposition to the purposes of Eros and placing itself at the service of the opposing drive impulses.'



‘The death drives are by their nature mute . . . the clamour of life proceeds for the most part from Eros.’<sup>161</sup> While the drives in the id were still attached to Eros, love reigned in the ego(primary narcissism), but when the sadistic components of the sexual drives joined the destructive drives because of their disconnection/defusion from Eros, the id fended off the tensions of Eros, because of unpleasure. Freud’s pleasure principle which had derived from the principles of constancy and homeostasis and had joined the Nirvana principle of Barbara Low(1920g), became a descent to Hades. Nirvana, a kind of beatitude, was achieved first by obeying *Eros* striving for satisfaction of the sexual trends through ‘orgasm’, itself a sort of dying. Then, the death drive and the destructive trends of superego eliminated Eros, while the ego by ‘sublimating some of the libido for itself . . . assists the id in its work of mastering the tensions.’<sup>162</sup>

This unexpected end of the ‘second topography’ towards the dominance of the death drive and desexualization, may explain why Freud tried different structural rearrangements after the 1930s. What the post-freudians thought he did was a kind of restauration of the ego in its autonomy. This led them to the deviations of ‘ego psychology’ and ‘object relations theory’. They thought that this was Freud’s shift with and after ‘Inhibitions, Symptoms and Anxiety’ (1926d).

Following a different, more Lacanian reading of Freud, we consider that Freud did not advocate the strengthening of the ego in his later work, but stressed its division. There is one *Ich* -conscious but mostly unconscious- whose structure is divided by anxiety caused by the

---

<sup>161</sup> Ibid.

<sup>162</sup> Ibid., 47.

threat of castration. Lacan who had found a third topography of Freud in the developments of ‘*Massenpsychologie und Ich-analyse*’ (1921c), as he underlined in his Seminar IX *Identification* (1961-1962), also found another tripartite structure of the psyche in Freud’s ‘Inhibitions, Symptom and Anxiety’ (1926d), which led him to the knots of his later teaching(1971-80).

The idea that the castration complex had a major impact on the formation of the neuroses was present for some time in Freud’s work. It was discussed in Freud’s second theory of anxiety in ‘Inhibition, Symptom, Anxiety’ (1926d). Then, his paper on ‘Fetishism’ (1927e) introduced a new clinical structure next to obsession, phobia, hysteria and the psychoses: this new structure, perversion, was the effect of a ‘denial’ ( *Verleugnung*) of castration, as was obvious in fetishism. The acknowledgment and denial of castration lead Freud to formulate a true rift, a hole in the ego, which he developed in a short paper written just before his death, in 1938, ‘The Splitting of the Ego in the Process of Defence’ ( *Die Ichspaltung im Abwehrvorgang*, 1940e[1938]). He advocated that the mechanism was present in every neurosis.

Freud was aware that he was describing something ‘entirely new and puzzling’ - the ego could acknowledge a psychological perception and at the same time behave as if it had not. The danger signalled by castration anxiety and the demands of the drives were both tackled by the subject in an ingenuous way. However, as Freud put it: ‘Everything has to be paid for in

one way or the other and this success is achieved at the price of a rift in the ego which never heals but which increases as time goes on.’<sup>163</sup>

The traumatic perception in question was the lack of penis in female subjects. A fetish and a symptom were the formations of the subject’s compromise.

On the other hand, in ‘An Outline of Psychoanalysis’ (1940a [1938]), written earlier that same year, Freud stressed that ~~we do not know much~~ about our ‘psyche’, that what lies between its somatic organ and our consciousness ‘is unknown to us . . .’. He started off with two hypotheses: localization first: the psyche is ‘an apparatus extended in space’ (Descartes had called it *l’étendue*), ‘made of several portions’; we know that as the first topography. Then, he took the individual development, what he called ‘his ego psychology’, and started from the drives, which he called the ‘id’, from which the ego developed under the influence of the external world. The ego had various tasks to perform with regards to the external world, but also had to deal with the ‘internal events’ in relation to the id, so it had to exercise some control on the drives, following the pleasure principle. It used anxiety as a signal for danger, the increase of tension. Finally a precipitate of the parental influence and through them of cultural, racial and national influences led to another instance, the superego.<sup>164</sup>

That was the scaffold of the second topography but its balance was constantly under threat. It was not only the rift in the ego caused by the ‘castration complex’ that left it exposed to

---

<sup>163</sup> Freud, S., 1940e [1938], S.E. **23**, 275-76.

<sup>164</sup> Ibid., 146.

disintegration. It was also the almost total reign of the drives demanding satisfaction, as Freud said, and especially of the sadistic and aggressive drives in the id:

The power of the id expresses the true purpose of the individual organism's life. This consists in the satisfaction of its innate needs. No such purpose as that of keeping itself alive or of protecting itself from dangers by means of anxiety can be attributed to the id. That is the task of the ego etc . . . The superego may bring fresh needs to the fore, but its main function remains the limitation of satisfactions'<sup>165</sup>

In the superego the id had an ally. With the superego 'considerable amounts of the aggressive instinct are fixated in the interior of the ego and operate there self-destructively.'<sup>166</sup> Thus the ego is weakened and now, in his testament, Freud advocates its strengthening through the psychoanalytic work of 'self-knowledge'.<sup>167</sup> And this is only 'a first step'.

There is a second hypothesis which includes 'the concomitant somatic phenomena' in the unconscious. Freud proposes to see in them 'the true essence of what is psychical'.<sup>168</sup> He further argues that psychoanalysis 'explains the supposedly somatic concomitant phenomena as being what is truly psychical, and thus in the first instance disregards the quality of consciousness'.<sup>169</sup>

All this is quite different from ego psychology or object relations theory. propositions by Freud's last propositions, first of a rift, a hole in the ego that keeps increasing with time, and the need to heal that rift with what is 'somatic concomitant phenomena' contain the seeds of

---

<sup>165</sup> Ibid., 148.

<sup>166</sup> Ibid., 150.

<sup>167</sup> Ibid., 177.

<sup>168</sup> Ibid., 157.

<sup>169</sup> Ibid., 158.

ideas, which we find in the last Lacan, is a re-arrangement of the psychical, together with the somatic. The psychical itself has three qualities, as Freud says, is made of three classes of materials, three registrations, unconscious, preconscious, and conscious. Neither of these qualities is absolute or permanent.<sup>170</sup> ‘Conscious processes are on the periphery of the ego’.

<sup>171</sup> Parts of the superego are unconscious, and the superego is inserted between the external and the internal world. And this is not the whole story.

From Freud’s formulations of the second topography we saw two psychoanalytic schools emerge, ‘ego psychology’ and ‘object relations’ theory. Lacan, on the other hand approached them with with the formalizations of logic and topology. Freud’s last period contained intuitions which we also find in some formalisations of the last Lacan. There was, in the meantime, a particular attempt in France around the 1950s, by Daniel Lagache, to include psychoanalysis within his psychological project including a theory of the ‘personality’s structure’.

---

<sup>170</sup> Ibid., 160.

<sup>171</sup> Ibid., 162.

## CHAPTER 4

### THE OPTICAL SCHEMA

#### A. A structural and topological argument

In ‘The Ego and the Id’ (1923b) Freud proposed an ego equivalent to the mental apparatus, parts of which were unconscious. Consciousness was on the *surface*. On the other hand, the part representing the drives, lying deeper in the anatomical structure, he called them *das Es*. He developed a new grade in the ego, the superego, which seemed to take the place of the ego ideal. The superego had a relation with the unconscious part of the ego (‘id’), inheriting perhaps its impulses (‘or was it the ego that inherited them?’ Freud wondered). Then there was the repressed cut off from the ego by resistances. The defensive strategies of the ego were also unconscious, but not repressed. As it was, only a part of the ego was a ‘coherent mental organization’ (*das gesamte Ich*)<sup>1</sup> to which consciousness became attached. It was only the *surface* of the psychical apparatus which had the control of perception and motility. Consciousness was that surface.<sup>2</sup>

Freud asserted that everything received from the outside, sense-perceptions, feelings and sensations were *Cs. from the start* , but he wondered how consciousness came to the thought–processes which were internal perceptions. This was the problem he faced, if his

---

<sup>1</sup> Freud, S., (1923b), S.E. 19, 17. *Gesamt* means: whole, entire, in its totality. Strachey translated it as ‘coherent’. There was an antinomy almost between what Strachey was translating and what Freud was proposing. In the same work Freud said that the ego was ‘a precipitate of abandoned ego cathexes,’ (ibid., 29), and an ‘aggregate of identifications,’ which sometimes existed simultaneously (as ‘multiple personalities’, ibid., 31). He also recognized that a part of the ego became split from it, the repressed.

<sup>2</sup> ‘. . . consciousness is the surface of the mental apparatus; that is . . . a function to a system that is spatially the first one reached from the external world –and spatially not only in the functional sense, but on this occasion, also in the sense of anatomical dissection.’ Ibid., 19.

spatial idea was taken ‘topographically’ and not ‘dynamically’. As is very well known, a lot of complex thought-processes take place without any involvement of consciousness. How can they become conscious? Only if ideas (thoughts) were linked to verbal associations, then they became conscious or rather formed the system called the ‘Preconscious’ (*Pcs.*). Unconscious thoughts were and remained unknown, constituted the *real* Ucs., unless memory traces were brought into connexion with word-representations<sup>3</sup> thanks to the *Pcs.* system which, in the first topography was ‘our official ego’. *The Pcs.* was a ‘latent unconscious,’ but the comparison was confusing, as Freud recognized.

Freud had said already in ‘The Interpretation of Dreams’ (1900a) that consciousness and memory traces were incompatible, because they were not in the same place. This time he dealt with the question using the dynamic, quantitative criterion, the movement of cathexis:

‘We think of mnemic residues as being contained in systems, which are directly adjacent to the system *Pcpt./Cs.*, so that the cathexes of those residues can readily extend from within on to the elements of the latter system.’ So, why is it ‘that the most vivid memory is always distinguishable both from a hallucination and from an external perception?’<sup>4</sup>

He answered:

‘. . . When a memory is revived, the cathexis remains in the mnemic system, whereas a hallucination, which is not distinguishable from a perception, can arise when the cathexis does not merely spread from the memory trace on the *Pcpt.* element, but passes over to it *entirely*.’<sup>5</sup>

---

<sup>3</sup> Ibid., 20. In his paper ‘The Unconscious’ (1915e), Freud argued that ‘the conscious [re]presentation is split up into the ‘[re]presentation of the word’ (*Wortvorstellung*) and the ‘[re]presentation of the thing’ (*Sachevorstellung*), and said: ‘the unconscious [re]presentation is the thing alone.’ (Freud S., 1915e, S. E., 14, 201).

<sup>4</sup> Ibid.

<sup>5</sup> Ibid.

Here, surely topology and not topography would have helped Freud's questioning, as a theory of space allowing continuity in transformations of space where different surfaces and shapes could have the same topological properties. Freud thought instead of an entirely new shape and new conception of the psychical apparatus, a second topography where the first seemed to have failed.

Freud's schema of the second topography, especially the one he reworked in his Lecture XXXI of the 'New Introductory Lectures' (1933[1932]), did not show the decomposition of personality (*Die Zerlegung der Persönlichkeit*), as Freud had hoped. It was rather a failure. Freud recognised that 'he cannot do justice to the characteristics of the mind' with it as 'it has linear outlines like those of a drawing or a primitive painting'.<sup>6</sup> 'It would have been better represented, he suggested, by a modern painting with areas of colour melting into each other.' Its borders were not clear, its divisions not sharp. Here we can argue that both, the diagram in 'The Ego and the Id' (1923b) and the amended diagram of 'Lecture XXXI' (1933a) lacked a proper topological support. However, Lacan noticed that it could be seen topologically as a closed surface, a sphere or a circle defining an exterior, the first Other, from an interior: He described it as 'the geometry of a bag, the bag of drives [which] we meet it again in topology. On a surface this bag forms a circle and a circle with an inside and an outside.'<sup>7</sup>

---

<sup>6</sup> Freud, S., (1933a), S.E. 22, 79. As its new name showed the id was something we know very little of, 'it is the dark, inaccessible part of our personality...we approach it with analogies, we call it a chaos, a cauldron full of seething somatic excitations.' (Ibid., 73). The system *Pcpt-Cs* was, on the contrary, 'turned towards the external world', it was like 'the sense organ of the entire apparatus' (ibid., 75). The ego was perceived there rather as weak, serving three severe masters, the external world, the superego and the id. The id provided all the energy. Threatened, the ego reacted by anxiety (ibid., 77).

<sup>7</sup> Lacan, J., (1974-1975) *RSI*, Seminar Book XXII, 10 Dec. 1974.



In 'The Ego and the Id' (1923b), Freud described the individual as a 'psychical id unknown and unconscious upon whose surface rests the ego, developed from its nucleus, the Pcpt. system'. To show the latter, he drew a tuber sitting on top as the germinal disc sits on the ovum, said that the ego was 'not sharply separated from the id', that 'its lower portion merged into it.' From the brain's external membrane (the *Pcpt*, *Cs* system) it went downwards. It extended inside as internal perceptions (*Pcs.*). The ego was the projection of the bodily surface, a surface differentiation. He then followed it 'dipping its roots' into the id, of which it was a mere 'representation'. Other complexities were added with the introduction of the superego, which stood like a cap on the side of the ego's head, but a hat it wore awry, representing both, the demands of the external world and of the id.<sup>8</sup>

In 'New Introductory Lectures' (1933a), *Lecture XXXI*, he started the description from the other side, from the id.

'. . . the ego driven by the id, confined by the superego, repulsed by reality, struggles to master its economic task of bringing about harmony among the forces and influences working in and upon it . . . breaks out into anxiety, realistic anxiety . . . moral anxiety . . . and neurotic anxiety . . .'

<sup>9</sup>

In 'An Outline of Psychoanalysis' (1940a [1938]) Freud said clearly that the ego was less attached to consciousness; consciousness was placed on the margins and the periphery of the ego. As Freud added there, the ego was 'weakened by the internal conflict and we must go to its aid.'<sup>10</sup>

---

<sup>8</sup> Freud, S., (1923b), 24. Cf.: This thesis, Chapter 3, p. 156

<sup>9</sup> Freud, S., (1933a), 78.

<sup>10</sup> Freud, S., (1940a[1938]), S.E. **23**, 163. 'Originally, to be sure, everything was id; the ego has developed out of the id by the continual influence of the external world . . .' (op. cit., 173).

The second topography dominated psychoanalytic literature from the 1930s to the 1950s, its interpretation defining the differences of the two main tendencies[schools] Kleinian and Anna-Freudian. The ‘physicalist’ conception of it, as the IPA psychoanalysts in France saw it later, was judged an obstacle to the development of psychoanalysis.<sup>11</sup>

Both post-Freudian schools of psychoanalysis took the second topography as their theoretical compass, Anna Freud’s ideas contributed to the formation of what we call ‘ego psychology’ which was clearly formulated in the late 1940s. Starting earlier, Melanie Klein’s theories focused on the archaic superego in its relation to the demands of the id. In that she was closer to Freud’s hypotheses.<sup>12</sup>

Freud’s second topography seemed to raise more questions than it answered. There were problems in its topographical description and a not so successful articulation between the psychical systems. In the 1950s, Lacan started addressing these problems putting in place another ‘trinity’, the three registers or orders of the psychical experience, symbolic, imaginary and real, which, although he said he found them in Freud’s five major clinical cases, he formalized them with the help of concepts he found in psychiatry, linguistics,

---

<sup>11</sup> Indeed a series of papers published in the issue of Sept.-Oct. 1985 in the *Revue Française de Psychanalyse* under the general title: ‘A crisis of meta-psychology’, questioned its most important premises. (Allouch, J., ‘Ouverture du premier congrès de l’e. l. p’, *Littoral*, no 22, 1987, Paris).

<sup>12</sup> Freud had suggested that the superego was more archaic than the ego itself, that it inherited the id’s demands (of the drives), but it was also ‘already represented’ in the id by the cultural inheritance of the egos of previous generations. In ‘Civilization and its Discontents’ (1930a), Freud referred to a cultural superego (*Kulturüberich*), similar to the individual superego which sets up its ideals and demands concerning a community (Freud, S., 1930a, S.E. 21, 142). As he pointed out in his paper on ‘Humour’ (1927d): ‘. . . this ego is not a simple entity. It harbours within it, as its nucleus, a special agency, the superego. Sometimes it is merged with the superego . . . whereas in other circumstances it is differentiated from it.’ (Freud, S., 1927d, S.E. 21, 164).

anthropology, philosophy, and later mathematics and topology. But, they were concepts opening the keys to the clinical practice of Freud, in an astonishing way.

He started by introducing the imaginary register as the ego to which the body- image belonged and in parallel developed the symbolic structure of speech and language with which the imaginary was articulated. Those two perspectives, ‘the articulation of the subject with the little other and the articulation of the subject with the big Other,’ were already present in his ‘Presentation of Psychological Causality’ (*Écrits*, 1966 [1946]), which preceded his ‘Mirror Stage’ (*Écrits*, 1966 [1949]). He focused on the symbolic register for the next ten years of his teaching (1950-1960) and from the 1960s onwards he formalized the already introduced register of the real and the object called *a*, belonging to it. He developed the real with the help of topology, surfaces and knots.

The optical schema, which we examine in this chapter in the context of Lacan’s ‘Remarks on Daniel Lagache’s Presentation’ (*Écrits*, 1966 [1960]), was presented first in ‘Freud’s Papers on Technique’ (1953-54), Seminar Book I, as an articulation between imaginary and real, depending on the place that the subject (represented as an eye), occupied in the symbolic world. With an experiment from physics (Bouasse’s reversed bouquet of flowers), Lacan explained why Freud’s three systems (ego, id, and superego) ‘should not be taken either as substantial or epiphenomenal in relation to the modification of the apparatus itself . . . [but] they should be interpreted as optical schemata’.<sup>13</sup>

---

<sup>13</sup> Lacan, J. (1953-1954), *Freud’s Papers on Technique*, Seminar Book I, ‘The two narcissisms’, 24 March, 1954, op. cit., 1988, p. 123. The three registers were first presented in 1953. At the time there was no proper status for the real or the external object. Later, identification to the signifier, followed by a splitting within the primitive ego (*Urlich*), had led to the constitution of *Ich*, *Lustich*, and object *a*.

After the ‘optical schema’, and ‘schema L’,<sup>14</sup> Lacan constructed another schema in two successive Seminars, *Formations of the Unconscious* (1955-56), Seminar Book V, and *Desire and its Interpretation* (1956-57), Seminar Book VI. It is known as the ‘graph of desire.’<sup>15</sup>

Freud’s ego ideal and the ideal ego found their place in Lacan’s optical schema too. As for the external object, it was involved in the formation of the ideal ego through identification, which Freud had described so well in ‘Group Psychology’ (1921c), and in which Lacan found a third topography in Freud, but also became the support of the function of object a. *Identification*, (1961-1962), Seminar Book IX, made the splitting of the subject clearer by introducing the real.

### **B. Lagache and his approach of Freudian meta-psychology**

Daniel Lagache, member of the ‘Paris Psychoanalytic Society’ (SPP) and of the ‘French Society of Psychoanalysis’ (SFP) which together with Jacques Lacan and Françoise Dolto they founded in 1953,<sup>16</sup> had been trained as a psychiatrist, in the tradition of Janet and Ribot, and later as a psychoanalyst, influenced by both psychology, and psychoanalytic object relations theory. He was ‘the last of a tradition of physicians-philosophers and

---

<sup>14</sup> Lacan, J., (1954-1955), *The Ego in Freud’s Theory and in the Technique of Psychoanalysis*, Seminar Book II, 25 May 1955 (1988, p. 243).

<sup>15</sup> Using topology Lacan later extracted the surface of the torus from the Graph of Desire (1961-1962), Seminar Book IX *Identification*, unpublished). Identification to the signifier splits the subject leaving a remainder, object a.

<sup>16</sup> All three were members of the SPP which they quit in the midst of a crisis concerning the functioning of the ‘Institute of Psychoanalysis’, and the candidature of Jacques Lacan as President; ‘La scission de 1953’, *Ornicar* No. 7, Supplement, 1976.

inaugurated another tradition, that of psychologists-psychoanalysts'.<sup>16</sup> One of the first psychoanalysts to obtain the post of professor of psychology he worked on a vast project of modernization and professionalization of psychology in which he aimed to include psychoanalysis. Six Volumes of his Works (*Oeuvres*) were published in Paris between 1956 and 1977.<sup>17</sup> He died in 1972.

Lagache wanted to fill the gap he perceived in Freudian meta-psychology left from 'the demolition of the autonomous ego', which, according to him started well before Freud, with Janet and Ribot.<sup>18</sup> That gap, he argued, called to be filled with 'a relative and partial autonomy of the subject.'<sup>19</sup>

Lagache focused on Freud's second topography as a personalistic, almost anthropomorphic 'model', which called for a freeing of the ego (from its identifications with the superego, for example) without ignoring its 'heteronomy'. He thought he could be helped by 'concrete psychology.'<sup>20</sup>

---

<sup>17</sup> A selection appeared in English in 1993 under the title: *The Works of Daniel Lagache*, Selected Writings, Karnac Books, London.

<sup>18</sup> The French psychiatrist Théodule Ribot became known for his work: *The Personality's Illnesses* (1894) where he defended the idea that the ego's unity and autonomy was dissolved in the alterations of the ego and the multiple personalities of the various 'personality's illnesses'.

<sup>19</sup> Lagache, D., 'La fascination de la conscience par le moi' (1957), *Oeuvres*, Vol. IV (1956-62). This paper was translated in 'The Works of Daniel Lagache' (1993), as 'Ego's Fascination with Consciousness' (op. cit., part IV, 193ff.)

<sup>20</sup> The term 'concrete psychology' was borrowed by Lagache from the Marxist philosopher G. Politzer, but never acknowledged. Politzer became interested in psychoanalysis and psychology. He wanted to introduce a 'concrete psychology', as opposed to the abstractions of academic psychology. G. Politzer's major work were his two volumes of *Writings*, and especially vol. 2, 'The Foundations of Psychology', (1969). He was executed in France in 1942 as part of the resistance.

‘Ego’s fascination with consciousness’ (1977 [1957]), was the earliest of the two papers which we examine briefly here. Lagache argued that Freud’s first topography was a ‘naturalistic’, and ‘physiological model’ – in that he agreed with the Ego psychologists- and therefore ‘outside the psychoanalytic field, while the second topography rightfully belonged to the psychoanalytic field, not so much because of the distinction of the three systems, *ego*, *id*, and *superego*, but because Freud had underlined there the ego’s dependency from the two other systems.<sup>21</sup> Lagache thought that this called for a ‘freeing the ego’ (*un dégage ment du moi*) from its dependent relations.

In that same paper Lagache took a philosophical view of the Freudian *Ich*, and argued that:

‘The ego of concrete existence is very different from the Freudian *Ich* which is rather the subject whose consciousness is an essential but not permanent attribute and that bears some resemblance to the transcendental subject of the philosophers. The ego of concrete existence, as we understand it, is a transcendent object for the conscious subject’.<sup>22</sup>

In the second paper (1961 [1958]), ‘Psychoanalysis and the Structure of Personality’, which Lagache presented at the Royaumont Colloquium of the SFP, he started by declaring his ‘structuralist’ credentials (of which Lacan will become very critical.)

---

<sup>21</sup> Freud in his later work sought to redress the balance : ‘The ego is weakened by the internal conflict and we must go to its help.’ (Freud, S., 1940a [1938], S.E. 23, 173) ‘An Outline of Psychoanalysis’ was Freud’s last major metapsychological text, in which he gave his ‘final assessment of psychoanalysis’s main tenets’. In many areas, as for example the theory of the drives, he returned to his earlier views.

<sup>22</sup> For the terms ‘transcendent’ and ‘transcendental’ we refer to Caygill’s H., *A Kant Dictionary*, (1995). Kant’s terms are not applicable to Freud’s *Ich*. Interested in philosophy, which was his first choice, Freud advised against the use of philosophical terms in psychoanalysis and avoided the term ‘subject’, as much as he could. There are indeed very few occurrences of it usually in contrast to ‘object’, as in the example of identification either to the subject or to the object of *Ich: Ich-Subjekt* or *Ich-Objekt* (1921c, S. E., 18, 106). Instead he used the grammatical term, *Ich*, the subject of the sentence, the subject about which he definitely said that it was split, split between the observer and the observed in dreams, or in the delusions of persecution, or in the process of defence. In the paper on narcissism (1914c) *Ich*, on the contrary, was an object, an object of libido (secondary narcissism), and consequently became the reservoir of libido itself extending to external objects (primary narcissism) *Ich* could chose an external object as its *Ichideal*, and either identify with it in which case it became *Idealich*, lovable to itself and others, or condemned by it as inadequate in melancholia.

‘Today anthropology is structural ...we begin with the idea that we are not dealing with isolated elements or with sums of elements, but rather with sets whose parts are themselves structured . . . Personality is itself a structure . . . A differentiated structure within a structure which comprises it, it comprises other structures.’<sup>23</sup>

Thus, Lagache underlined the fact that ‘he [Freud] brought out the structural point of view as early as the ‘Project’ (1950a [1895]) and in particular in ‘The Interpretation of Dreams.’ (1900a). It was ‘one of Freud’s merits,’ he said. While Freud’s psychical apparatus as finalized in the ‘Interpretation of Dreams’ was an ‘optical fiction’, he added other criteria later, amongst them the ‘genetic’ and the ‘adaptation’ or ‘object relations’ criterion. Lagache favoured Freud’s second topography because it was ‘a personal structure . . . not only a psychoanalytical but also an analytical conception in the wider sense of the word.’<sup>24</sup>

However, as we will find out, his interpretation of Freudian metapsychology can be glimpsed in that statement:

‘For Freud the theory of the drives was more fundamental than the theory of the psychical apparatus. The structure of personality is the durable effect of the choices and the rejections effected by the subject.’<sup>25</sup>

Lagache underlined that the prevailing view of the personal structure in all pre-analytic psychology and psychopathology was the ego’s heteronomy.<sup>26</sup> On the other hand, although

---

<sup>23</sup> Lagache, D. ‘Psychoanalysis and Personality Structure’ (1961), *La Psychanalyse, No 6*, 191. Levi-Strauss published his ‘Structural Anthropology’ in 1958, shortly before the Royaumont Colloquium took place.

<sup>24</sup> Op. cit., 193. Also, in p. 192: There are two conceptions of personal structure in modern personality theory, he said, and distinguished between the hierarchy of the psychical systems of ‘ego psychology’ and the more fluid conception (the object relations theory), of which he was an advocate: ‘a system of relations which are not directly observable.’

<sup>25</sup> Ibid.

<sup>26</sup> Here Lagache referred to Th. Ribot, whose ideas about the ego in Ribot’s major work ‘The Personality’s Illnesses.’ (1894), he criticized.

Freud too first used the language of the weak ego fractured in ‘multiple personalities,’ he moved quickly to a two systems ‘model’, the ‘Preconscious’ (*Pcs.*), which corresponded to ‘our official ego’, as Freud had said, and the ‘Unconscious’. But, for Lagache the problem with the first topography was that the ‘Preconscious’ (*Pcs.*) was subordinated to the ‘Unconscious’ (*Ucs.*), and the pleasure/un-pleasure principle was stronger than the reality principle:

‘The ascendancy of the unconscious system over the preconscious, of primary over secondary processes, of the un-pleasure over the reality principle, not named but present, define undoubtedly the heteronomy of the subject.’<sup>27</sup>

Lagache also found continuity between the first and the second topography of Freud, despite their differences, and underlined Freud’s continuing interest in the ego during the middle period of his work (1910-1920), unlike what Heinz Hartmann thought.<sup>28</sup>

The turning point of the 1920s brought in the new duality of drives. The second topography was developed as a consequence of that. For Lagache the second topography with the three instances *ego*, *id* and *superego* was a better suited model for psychoanalysis, because it was a personalistic, even anthropomorphic model which gave a relative autonomy to the ego.

‘Even if the unconscious quality of the ego’s defensive operations were the decisive motivation of the revision, we should add that the distinction between the *id*, the *ego* and the *superego* was of a more “personalistic” style; even if the term ‘psychical apparatus’ was not abandoned, Freud in his last writings also talked about the ‘psychical personality.’<sup>29</sup>

<sup>27</sup> Lagache, D., op. cit., 195.

<sup>28</sup> Hartmann, H. (1956), ‘The Development of the Concept of the Ego in Freud’s Work’.

<sup>29</sup> Each one of the three agencies is autonomous, but they also have to fit in the whole of the personality structure. But because of the excessive insistence of some of Freud’s pupils on the heteronomy of the ego, Freud returned to redress the balance around the ego’s autonomy in ‘Inhibitions, Symptoms, and Anxiety’ (1926d), and made the ego the sole agent of the defences (Lagache, D., 1961, 196). Freud used the term ‘personality’ later in his work, as we see in Lecture XXXI of the ‘New Introductory Lectures’ (1933a), ‘The dissection of Personality’ (*Die Zerlegung der Persönlichkeit*) S.E. 22, 57ff.



Also, thanks to the introduction of the ‘ego ideal’ in ‘Group Psychology’ (1921c), censorship which had been only a function in the first model, became a separate agency.

Lagache opposed the ‘naturalistic and physiological model’ of the first topography, to the structural and ‘personalistic’ of the second. He had however some criticisms for the ego psychologists’ approach of the second topography because it was ‘at a distance from the experience’.

‘ . . . The verbal form of interpretation should not bring in structural concepts, because they are too remote from the experience so that their use may favour reification. If the patient speaks that language, we see a resistance in that. The only language that we cannot avoid to speak is that of inter-subjective relations and identifications.’<sup>30</sup>

Against the dangers of what he called the ‘reification’, ‘substantification’, or ‘personification’ of the second topography, he preferred the object-relations theory which was developed from the 1930s onwards in psychoanalysis, because it put the emphasis on inter-subjective relations as fashioning the intra-subjective relations. As he declared inter-subjective relations and identifications ‘play a central role in the structuring of the psychical personality.’<sup>31</sup>

### **C. On inter-subjectivity**

By choosing the second topography, as a structural as well as ‘personalistic model’, and by focusing on the inter-subjective, social and cultural relations from which the intra-

---

<sup>30</sup> Lagache, D., op. cit., 197.

<sup>31</sup> Ibid.

subjective relations genetically would derive, Lagache believed he could avoid ‘the naïve idealism which makes the personal world derive from subjectivity.’ He put it as follows: ‘Before existing in itself, by itself, and for itself, the child exists for and by another. It is a pole of expectations, projects, attributes. What is true at the moment of conception remains true during life and even after life.’<sup>32</sup>

Although he recognized its value in his ‘Remarks’ (1966 [1960]), Lacan criticized the further development of that point by Lagache as ignoring the importance of language, the third element in human relations, of which however Lagache was well aware, when he talked of the ‘expectations, projects, attributes’ bestowed on the child before even it was born.

For, in Lagache too, we find idealism and intellectualism, when he proposes the genesis of the superego by identification to the idealised image of the parents and to the superego of the grand-parents, and calls it a ‘transcendental model.’<sup>33</sup>

Although in his approach in ‘Psychoanalysis and the Structure of Personality’ (1958), Lagache wanted to be, first of all, a structuralist, and to present the ‘psychological field’ as ‘the set of relations between the organism and its environment’, his use of structuralism was not rigorous enough, as Lacan pointed out:

‘I accept the category “set” with which he introduces it [the debate], insofar as it avoids the implications of totality or purifies them. But this does not mean that its elements

---

<sup>32</sup> Ibid., 200.

<sup>33</sup> Ibid.

are neither isolated nor summable [as Lagache claims] – at least if we are looking, in the notion of set, for some guarantee of the rigor it has in mathematical theory.’<sup>34</sup>

Lagache professed a structural, mathematical, and geometric analysis but followed principally the genetic and developmental one inspired by the object relations theory.

‘The child begins to exist in itself before conception,’ as Lagache underlined. Significantly enough, he placed the beginning of prenatal existence in the middle of gestation when ‘the being for another is modified by “incarnation”, when the foetus begins to show ‘the first manifestations of activity.’<sup>35</sup>

He opposed the extreme view of an absence of differentiation, therefore of an absence of a subject, object or consciousness and ‘therefore of object relations’ in the beginning of individual life. There is, he said, a minimum autonomy and differentiation from the beginning.

‘Without existing as a cognitive structure, the subject functions and is realized successively in the needs which awaken him and motivate him, in the acts which orient him and in the feeding process which appeases him and sends him to sleep.’<sup>36</sup>

Object-relations exist from the start too. The relation of the baby to the breast is a true object relation, Lagache said. However, there is no sense of separate identities, there is no differentiation in the beginning between subject and object.

---

<sup>34</sup> Lacan, J., (1966 [1960]), ‘Remarks on Daniel Lagache’s Presentation’, *Ecrits*, Fink 2006, 544.

<sup>35</sup> From the beginning he had announced that the relation between organism and situation was not only ‘biologically inspired’, but also ‘a geometrical necessity.’ Lagache, D. (1961), op. cit., 191.

<sup>36</sup> *Ibid.*, 201.

In relation to the mother, while in the intrauterine life there was a ‘parasitic union’ with her, after birth there was ‘symbiotic participation,’ in as long as the mother satisfied the needs. It was only when the mother was absent that the child could experience himself ‘as impotent and distressed.’

Thus, according to Lagache, the first modality of existence in the womb was ‘being for another’ (*être pour autrui*), followed in the middle of gestation by ‘being in itself’ (*être en soi*). After birth ‘being thanks to another’ (*être par autrui*) was the first modality, although ‘being for oneself’ (*être pour soi*), that is the first conscious experience begins to act as a mediation between ‘being for another’ and ‘being in oneself’ of prenatal existence.’<sup>37</sup>

Lagache proposed ‘identification’, in which he distinguished introjections from projections, as the next step and the first mode of differentiation between subject and object. However ‘identification’ remained unstable. As Lacan remarked there was no differentiation for Lagache, because the other was only considered as ‘the fellow being’.<sup>38</sup> And this despite the fact that Lagache noted that the child takes its support on the discourse of the other:

‘in the establishment of its own identity the child leans on the point of view of the other(*autrui*), and this is shown clearly in language when during the second and third year the child talks of itself as the other talks to it or talks to itself as the other talks to it. A conjunction is established between being thanks to another (*être par autrui*) and being thanks to oneself (*être par soi*).’<sup>39</sup>

---

<sup>37</sup> Ibid.

<sup>38</sup> Ibid. The ego which develops within the inter-subjective conflict by learning and maturing, organizes its experiences in groupings such as ‘ego – non ego’, ‘ego – object’. But these first identifications/ differentiations are still unstable.

<sup>39</sup> Lagache, D., (1961), op. cit., 202.

Lagache called the next stage, in which differentiation became stable, ‘objectivisation’.<sup>40</sup>

‘The structures of the personal world become stable; the subject posits respectively the identity of its body and the material objects, *ego* and *alter ego*. This differential identification between the subject and the object is not reached at the same time in all areas.’<sup>41</sup>

Lagache cited Piaget for whom ‘the category of the object started being established between 14 and 18 months without yet being extended to the whole universe’. As for personal identity, ‘it was only posited in a stable manner at the end of the third year of life.’<sup>42</sup> As the child grew up, education reinforced objectivization and the ego- subject was only found in the intention and reflexion, in the adjusted action, but without ‘conscience of itself’ (without ego-conscience). On the other hand, the ego-object became ‘like a stranger’, a ‘transcendent object.’<sup>43</sup>

Using concepts from philosophy, and experimental psychology, Lagache’s structural developments were quite an idiosyncratic mixture. Freud, on the other hand was rigorous and quite careful not to use philosophical terms, and when he used the terms ‘ego- subject’ (*Ich-Subjekt*) and ‘ego-object’ (*Ich-Objekt*) a few times, there was no smack of philosophy. In ‘Drives and their Vicissitudes’(1915c) it was to denote the pendulum from the subject to the object of drive, in ‘Group Psychology and the Analysis of the Ego’(1921c), It was to show the splitting occurring at the heart of the identificatory processes.<sup>44</sup>

---

<sup>40</sup> In French, *objectivation*. It can be achieved only by means of putting one’s own person, attributes, states, acts, dispositions, at a distance, thus differentiating between *ego-subject* and *ego-object*. Ibid., 202-203.

<sup>41</sup> Ibid., 202.

<sup>42</sup> Ibid.

<sup>43</sup> Ibid., 203.

<sup>44</sup> This is what we are arguing here. Freud returned to the concept of a ‘splitting in the ego’, late in his work, a splitting occurring ‘in the process of defence’(1940c [1938]).

### D. Lagache on the 'id'

Lagache criticised strongly the biological reduction and simplification and the absence of any structural approach of the concept of the id, or of the drive, in post-Freudian literature. The id (*ça*), Lagache said, was not simply the 'reservoir' of the drives, even if that was a definition that Freud had used. The id was a structure and a well organized one. It was the 'id' and the Freudian Unconscious together, as Freud had described them, and 'their particularities constituted a positive and original mode of organization.'<sup>45</sup> It was not a biological concept as the post-freudians saw it, and that was true even when Freud expressed 'the most biologizing views' about it. There had been, indeed, a 'complacency' even in Freud himself, who favoured heredity at the expense of tradition in the formation of the id, and even abstractly prefigured the Oedipus complex and the castration complex in the id. For Lagache, on the contrary, 'it was the past of the race which informed individual destiny', while in Freud the id was inherited phylogenetically from previous egos before being inherited by the superego itself. Lagache acknowledged however, that this view included 'moral and psychological virtualities'.

Against some 'biological' conceptions, of the drives as 'physicochemical states of the body,' Lagache argued that the concept of the drive was a structure itself, of which Freud had described the elements:

'the bodily stuff of the drive was not anyone, it had a local source, an intensity and an aim; and whichever the contingency of the object it was not any one object which suited

---

<sup>45</sup> Lagache, D., (1961), 204.

it . . . if the subject of the drive has no representation of the object, it is not absurd to say that the drive aims at the value that the object constitutes.’<sup>46</sup>

From the structural point of view, the body itself was a structure with functions of control and integration, as Lagache added: ‘Without any recourse to costly phylogenetic hypotheses we have many reasons to admit that the specific and individual structure of the body prepares the structure of the personality.’<sup>47</sup> Thus, if for Freud the ego was an aggregate of the subject’s identifications to its loved and lost objects, ‘the id’, for Lagache, ‘was an aggregate of non-structured but functional object relations.’<sup>48</sup>

In was a curious development. ‘Object relations were submitted to condensation and syncretism’ which are rather linguistic processes. The id was the reservoir of the drives, but only literally, because according to Freud himself it contained 1. Hereditary and innate contents 2. Repressed and acquired contents. The first were inherited from other more ancient egos: ‘he [Freud] insisted on the fragility of the borders between the ego and the id, between the most superficial and the deepest strata’. As for the repressed contents of the unconscious, or the id, they were too object relations.<sup>49</sup>

Lagache’s model of the unconscious desire followed the pattern of the dynamic relation between the drive and the memory trace of the perception during which the need was first satisfied. The drive ‘reinvests the memory of that perception.’ It is a primary process

---

<sup>46</sup> Ibid.

<sup>47</sup> Op. cit., 205. Lagache argued that the drives were themselves virtual object relations. Even if there was no specific object originally attached to them, as Freud had argued, they searched for one early on and this was not any object; In the oral stage of the libido, for example, the object was predominantly the breast or another substitute, but not any substitute either.

<sup>48</sup> Op. cit., 206.

<sup>49</sup> Op. cit., 205-206.

seeking, as Freud had said, an identity between the perception, tending to the hallucination of the object, the aim of unconscious desires. ‘Indestructible, the latter [the unconscious desires] form the body of our being, thus constituted by the object relations and not by the drives without an object.’<sup>50</sup>

What he had to say about the fantasy was also quite ambivalent: fantasy was highly organised, a form of passage between the unconscious and the preconscious, hardly different from conscious phenomena, but it was also unconscious and incapable of becoming conscious. He found the perfect formula to express this ambiguity: ‘fantasy belonged to the preconscious qualitatively and to the unconscious quantitatively.’<sup>51</sup>

And where was the subject?

‘Not only the subject is not distinguished from the drive, the aim, and the object but it is scattered (*éparpillé*) amongst the different object-relations or their partial groupings. At the very end it is that absence of a coherent subject which characterizes at best the id’s organisation. This means that ‘the expression “the id” is its [the subject’s] functioning on an impersonal mode.’<sup>52</sup>

Lagache concluded:

‘The defensive and repressing operation excludes the drive from the coherent ego, sends it back to a kind of non-ego, internal and ignored. Hence, the character of strangeness of the drives, the off-springs of which logically force the subject to recognize their existence.’<sup>53</sup>

Lacan will talk of the exile of the drives in the id.

---

<sup>50</sup> Ibid.

<sup>51</sup> Ibid.

<sup>52</sup> Ibid. This reminds us of Lacan’s definition of the Freudian unconscious as the headless subject expressed in the impersonal mode: ‘it’, *ça*.

<sup>53</sup> Ibid.



### **E. Lagache's argument in favour of the ego's autonomy**

The ego's autonomy became a central theme in post-Freudian literature. It was a limited autonomy given the ego's heteronomy in its relation to the two other substructures, the superego and the id. The ego based its relative autonomy on the mechanisms of defence and repression. The relation of the ego to both internal and external reality was important. A modern development of the Freudian idea suggested that:

‘Those two autonomies, internal and external, if they entered in opposition to each other in extreme situations, normally they supported each other, hence the development of the modern Freudian idea that the relation to external reality constituted the core of the ego.’<sup>54</sup>

The excessive views in favour of the ego's heteronomy with regards to the two other systems, which were developed in the aftermath of Freud's ‘The Ego and the Id’ (1923b) were rectified by a stress on its autonomy underlined by Freud in ‘Inhibitions, Symptoms and Anxiety’ (1926d).<sup>55</sup> In Part III of that work, Freud redressed the balance between autonomy and heteronomy of the ego, addressed ‘the apparent contradictions’ stemming from the complexities of the ego's relations to the id, underlined the continuity between the three instances, and argued against a sharp division between the ego and the id. Although he said he was ‘justified in dividing the ego from the id, ‘on the other hand’ it was equally true that ‘the ego was identical with the id, and was merely a specially differentiated part of it.’ If ‘a real split’ between them two occurred, the ego would suffer weakness, while ‘bound up with the id and indistinguishable from it’, the ego was strong. The same was true

---

<sup>54</sup> Ibid.

<sup>55</sup> Lagache, D., *Ibid*; Freud, S., (1926d), S.E. 20, 97-98. This is the work in which Freud revised his first theory of anxiety, which he formulated in his early papers on the ‘Neuroses of Defence’ (1894, 1896), with a second theory, namely that anxiety is not ‘the cathectic energy of the repressed impulse’, but a signal of danger, a defence coming from the ego. Moreover, ‘anxiety is not newly created in repression’, but ‘is reproduced as an affective state in accordance with an already existing mnemonic image’ (Freud, S., *ibid.*, 93). It was linked to the castration complex.

as far as the relation between ego and superego was concerned. Split when there was a conflict, they merged in other circumstances. The same was true about repression. The id was not an organization while the ego was. When the ego sought to repress the impulses of the id, it was not true that a remainder always came to the rescue of the repressed. 'As a rule the repressed impulse remained isolated. Thus:

'Although the act of repression demonstrates the strength of the ego, in one particular it reveals the ego's powerlessness and how impervious to influence are the separate instinctual impulses of the id.'<sup>56</sup>

The defensive struggle between ego and id often ended in the formation of a symptom.

While supporting the ego's autonomy, limited - of course - by the other substructures' autonomy, Lagache questioned the 'semantic ambiguity' of the ego as a 'handy man', 'a kind of Master Jacques.' Based on what was thought a privileged relation of the ego with reality, it was enhanced with all sorts of virtues like 'organization and control of motility and perception, protection against external and internal stimuli, proof of reality, action and thought, techniques of deviation, anticipation, perception of time, inhibition, character traits, function of synthesis', a whole catalogue of functions, with which Hartmann especially had bestowed the ego (1949).<sup>57</sup> However both Lagache and Hartmann agreed that the ego's functions were antinomial and the most patent example was that 'the ego was at the same time the agent of repression and a repression-buster (défoulement), of

---

<sup>56</sup> Freud, S., (1926d), S.E. 20, 97. Straight after the formulation of his second topography, Freud had addressed the question of the relations between the ego and external reality and how the 'loss of reality' affected the psychological structure

<sup>57</sup> Lagache, D. (1961), 209; Hartmann, H. (1949). Hartmann was forced, however, to recognize that many of the ego's functions were in sharp contrast with each other.

illness and cure.’<sup>58</sup> Therefore the ego’s structure was not ‘homogenous’, it had both autonomous and heteronomous functions, which were in conflict. Therefore, as Lagache concluded: ‘It is only when this internal structure is recognized or at least drafted, that we will know if we can talk of the ego, in which case, in what sense and for what reasons.’<sup>59</sup>

He found the answer in what Freud had said about consciousness in the last section of the ‘Interpretation of Dreams’ (1900a).<sup>60</sup> To Lagache, consciousness (Cs.) at the end was rather close to a perception system (*Pcpt*) itself; a perception of internal psychological realities.<sup>61</sup> Ego and consciousness are disassociated by Lagache.

In Freud’s earlier developments concerning the economic point of view, in the ‘Project’ (1950[1895]), for example, quantity circulated freely (unbound) in the paths of the primary processes, where it could be displaced and/or condensed, but in the secondary processes quantity was bound with verbal associations.

---

<sup>58</sup> Lagache, D., *ibid.*, 210. The conflict was both intra-systemic and inter-systemic.

<sup>59</sup> *Ibid.*

<sup>60</sup> As we know, Freud developed the idea of the mental apparatus as a ‘compound instrument’ the components of which were named ‘agencies’ (*Instanzen*) or systems in Chapter VII of that work, and it was clear there that the ego - which was not named as such - was equivalent to the preconscious (*Pcs.*) and as such it controlled access to motility and consciousness. Censorship operated only at the motor end, between the preconscious (*Pcs.*) and the unconscious (*Ucs.*), consciousness (*Cs.*) was not a separate system ‘but a dependent relation of the preconscious (Freud, S., 1900a, S.E. 5, 541).

<sup>61</sup> In the process of dreams and hallucinations, the regressive movement of the psychical apparatus would bring one end next to the other and dream thoughts or visions and hallucinations of the waking life would receive their sensory qualities from the *Pcpt*. system. Conscious memories, on the other hand, had no sensory qualities (Freud, *ibid.*, 539-540) In the last section (F) of the same chapter consciousness became a separate system, which had the role of ‘a sense organ for the perception of psychical qualities.’ (Freud S., *ibid.*, 615). Topology would be necessary to show this. The surface of the Moebius strip which Lacan used to illustrate continuity between the psychical systems in the structure of the subject, added half a twist in the configuration of it, in order to account for the differentiation between internal and external processes.

On the contrary, in the last section of ‘The Interpretation of Dreams’ (1900a), Freud argued that consciousness was ‘a free energy’, while the unconscious cathexis was bound in fixations. Attention on the other hand was a free energy at the service of the preconscious. It seemed, as Lagache noted, ‘as if there was an abundance of cathexis used by consciousness and drawn from the verbal memories.’<sup>62</sup>

Lagache extended his argument to the dynamic point of view:

‘Consciousness introduced a more discriminative regulation. The activity of the preconscious remained under the dominance of the “pleasure principle”, (that is leaned towards a reduction of tensions), while consciousness would allow that the psychical apparatus invests and develops what is associated with liberation of unpleasure.’

What Freud could not solve, in the problem with consciousness, Lagache found it in the possibilities the ego had in the treatment. The analytic treatment with its rule of free association, he said, was enabling the ego to free itself by lifting the ‘second censorship’ between the preconscious and consciousness. The analysand was free from the choices and rejections of material dictated by consciousness, and did not need to obey certain rules dictated by external reality. Thus the treatment could lead to an external ‘heteronomy’ of the ego, but internally the ego continued to be dictated by the unconscious demands [of the id and superego]. Thanks to the fundamental rule again the analysand was free to choose or reject from the material, but saw its choices dictated by unconscious desires, against which

---

<sup>62</sup> Lagache, D., (1961), op. cit., 211. Freud had stressed that memories were unconscious to start with and that some memory traces remained permanently unconscious, while others could have access to consciousness through word-representations. Consciousness and memory, he said, were ‘mutually exclusive.’ (Freud, S., (1900a), S.E. 5, 540). If, at the end of that work, Freud clearly recognized consciousness as one of the systems of the psychical apparatus, and compared it to a perception system for the psychical qualities, later he was rather elusive, and said that there was not much hope one could place on consciousness, as it was not a structure but a quality and therefore could not be in the exclusive service of any of the three sub-structures, the id, the ego and the superego.

he used equally unconscious defences and resistances. This was the first censorship, between the Preconscious and the Unconscious. The analyst noted the resistances coming from the unconscious defences of the ego and tried to intervene. Was the ego that was resisting conscious or unconscious?

But Lacan remarked that the question should rather be ‘who resists?’ and he answered that it was the analyst.

For Lagache, the ego, which the analyst addressed in the treatment, was both autonomous and heteronomous: in relation to the external reality the ego was autonomous, but it was heteronomous in relation to the two internal systems, the id and the superego. But, within the structure of the ego itself, the ego was ‘affected by the motivation of its defences’, the unconscious desires, and as it tried to escape tensions, it finally succumbed to them: ‘The subject submits to its resistance which appears to us as a limitation of the ego’s autonomy. The analysand would like to avoid the tension, and sterility of his chatting, but he cannot.’<sup>63</sup>

In transference neurosis the ego was under the dominance of the automatism of repetition.<sup>64</sup> It tended towards ‘identity of perception’ which was an aim of the primary processes. It aimed at returning to the situation of the original satisfaction of the drive, and tried either to transform the environment according to unconscious desire or relive the unconscious memory in an ‘ecmnesic’ way. In this case the more the external autonomy increased, the

---

<sup>63</sup> Lagache, D., *ibid.*, 212.

<sup>64</sup> *Ibid.*

more the internal one diminished. As Lagache concluded, transference neurosis was a ‘condition of the ego’s dependency’. Resistance was a show of its autonomy, in the sense that it was unconscious. The repressed returned and unconscious desire was acted upon instead of being worked through. <sup>65</sup> Thus, as the ego of the analysand tried to become autonomous by ‘resisting transference’ and free association, it succumbed instead to the automatism of repetition. The analyst’s interpretations aimed to free the ego from the resistances and at the end modify the psychical structure. This technique was known as the analysis of the resistances. <sup>66</sup> When the analyst intervenes with an interpretation, the structure of the analytic field changes:

‘The analyst addresses the conscious and autonomous subject, the analysand is called to adopt a retrospective and rational attitude in relation to her account of the incident, and to “reflect” on what had been experienced and recounted in a non-reflective way.’ <sup>67</sup>

This technique of interpretation was ‘a call to the ego’s autonomy’, by the analyst’s speech. This is what Lagache argued.

According to the first Freudian structural theory, the aim of the treatment was ‘what was unconscious to become conscious,’ but the second structural theory postulated that ‘the ego had to extend in the expense of the id.’ Lagache argued in favour of the ego becoming autonomous and extending. But, as he had already underlined, he needed consciousness too

---

<sup>65</sup> Ibid., 213.

<sup>66</sup> Ibid. 214. With a clinical vignette, Lagache showed how the analyst addressed ‘the conscious subject’, by asking the analysand ‘to place herself in a position of thinking rationally about the incident, to reflect on her experience, to objectivise the experience with which she was initially identified.’ He considered that this technique, which he called the analysis of resistances, strengthened the autonomy of the ego in relation to its unconscious defences and the unpleasant feelings they generated, such as feelings of guilt and of failure, but, on the other hand, it reinforced its heteronomy in relation to the unconscious processes and to the unconscious defences as well.

<sup>67</sup> Ibid., 215.

to come in the picture: in the ‘Interpretation of Dreams’ (1900a) <sup>68</sup> Freud expressed a view about the dynamic and economic properties of consciousness, of consciousness as a free and mobile energy, the possibility of freedom from the constraints of the past, and that seemed to Lagache a good enough aim for the treatment, that ‘the aim of the treatment was the realisation of possibilities with the acceptance of limitations and tolerance to tension/unpleasure’.

Lagache thought that this was exactly what Freud meant by his aphorism: ‘*Wo es war, soll Ich werden*’, with which he concluded his Lecture XXXI (1933[1932]).<sup>69</sup>

### **G. Lacan’s answer to Lagache**

In an improvised intervention at the Royaumont Colloquium (July 1958), Lacan responded to Lagache’s presentation with detailed remarks, some praising, others mostly critical. In the second part of his talk he presented ‘the Optical Schema’. <sup>70</sup> A couple of years later during Easter 1960, his ‘Remarks on Daniel Lagache’s Presentation’ were given a final touch and later were published in the *Ecrits* (1966).<sup>71</sup>

---

<sup>68</sup> Cf.: Above, p. 216.

<sup>69</sup> Freud, S., (1933a), S.E. **22**, 80.

<sup>70</sup> It was first presented by Lacan in his Seminar *Freud’s Papers on Technique*, Book I, 1953-1954.

<sup>71</sup> Lacan, J., ‘Remarks on Daniel Lagache’s Presentation: “Psychoanalysis and Personality Structure”’, *Ecrits* (1966), transl. by Bruce Fink, 2006: 543-574, New York, London.

He was critical, straight from the start, of Lagache's so-called 'structuralism' and the use of the term 'personality' by him. He opposed his own conception of structuralism in psychoanalysis and used instead the term and concept of the subject.<sup>72</sup>

Lacan presented himself as following Claude Levi-Strauss usage of structuralism whose *Structural Anthropology* was published that same year, 1958. His was a rigorous use of the term 'structure' - he argued - which authorised him to put Lagache's claim of structuralism to the test. He accepted, 'the category "set" which Lagache introduced, insofar as it avoided the implications of totality or purified them.' But he thought that the elements of the set themselves were 'neither isolated nor summable, as Lagache claimed'. The proper mathematical use of the concept 'set' meant that its elements 'were themselves capable of symbolizing all the relations definable for the set, far beyond their separation and union.'<sup>73</sup>

Thus, 'not limited by any natural hierarchy', they had an autonomy, they were 'subsets' themselves and not simply 'parts' fitting in a totality, and certainly not in the supposed by Lagache 'totality of the organism.' They organised a geometrical field as Lagache indicated. Lagache had underlined the 'geometrical necessity' of the set, but made these elements to form systems of relations fitting in larger and larger units. Lacan proposed a topology instead.

'Structure is not form and we need to learn to think in terms of a topology that is necessitated by structure alone'. The first topology Lacan used was the articulation of the

---

<sup>72</sup> Some structuralists will that 'structuralism challenged any recourse to the human subject in general' (Piaget, J., *Structuralism*, Que sais-je, 1968, Paris).

<sup>73</sup> Lacan, J., op. cit., 544.



signifier, metaphor and metonymy, unlike Lagache who proposed ‘a choice between a structure that was . . . apparent and a structure . . . located at a distance from the experience.’ Lagache’s choice of the second topography as a theoretical model, with the systems ordered separately and within larger and larger units, was the geometry of a form to which Lacan opposed a topology, his ‘combinatory of the signifier,’ a language-like structure which did not operate as ‘a theoretical model’ but as ‘the original machine that directs [met en scene] the subject there. ‘He argued in favour of a recasting of ‘transcendental aesthetics.’<sup>74</sup>

‘Is it not structuralism that allows us to posit our experience as the field in which it (*ça*) speaks?’ He asked.

Freud’s topographies (*topiques*) may have been structures, but the systems ‘ego’, ‘id,’ ‘superego’, which Lagache ‘so delicately distinguished on the basis of their functions’, were not structures in the stricter sense. Freud had denied them any reality in the organism, and they were not even ‘fantasised realities.’ They were ‘instances’. They were not totalities. They had fissures and gaps, another reason why topology was a suitable approach. Lacan, strengthened by Freud’s argument, asserted: ‘The structure, of which I am talking to you, has nothing to do with the idea of the “structure of the organism” as supported by the most soundly based facts in Gestalt theory.’<sup>75</sup>

---

<sup>74</sup> Ibid.

<sup>75</sup> Lacan, J., op. cit., 545; Jean Piaget, ‘What is Structuralism?’ 48: ‘The central idea of *Gestalt* structuralism is that of totality’.

Moreover, as early as 'The Mirror Stage' - first presented in Marienbad in 1936, then rewritten and delivered on July 17, 1949 in Zurich at the Sixteenth International Congress of Psychoanalysis) - Lacan's 'I' (*je*) was not the ego in charge of consciousness and adaptation to reality.<sup>76</sup>

We know that Freud came upon an impasse in his many attempts to place consciousness in the psychical apparatus. For example, in the 'Project', consciousness was a function attributed to group  $\omega$  (in charge of attention and indications of reality and of quality) helping the ego in  $\psi$  to 'distinguish between a perception and a memory' ('Project', Part 1, [15]).<sup>77</sup>

Freud discussed the nature of consciousness at length in the end section of Chapter VII of 'The Interpretation of Dreams,' (1900a) and gave it one part to play: 'only that of a sense organ for the perception of psychological qualities'; Thus *Cs.* became a particular system which resembled the perceptual systems, *Pcp.* It received excitations from two directions, from the *Pcpt.* and from the interior of the apparatus. It had no memory. As philosophers before

---

<sup>76</sup> In 'The Mirror Stage as Formative of the *I* Function as Revealed in Psychoanalytic Experience' *I* was defined as a constituting *imago*, but one which was 'an exteriority in relation to the subject.' (*Ecrits*, op. cit., 75).

<sup>77</sup> Freud, S., (1950 [1895]), Appendix B, Extract from Freud's Letter 39 to Fliess of January 1, 1896, S.E. 1, 388-389. Freud had started with two kinds of nerve-endings. 'The free ones receive only quantity and conduct it to  $\psi$  by summation; they have no power, however, to evoke sensation -that is to affect  $\omega$ ... The nerve-paths which start from the end-organs do not conduct quantity but the qualitative characteristic peculiar to them; they add nothing to the amount in the  $\psi$  neurones, but merely put these neurones into a state of excitation. The  $\omega$  neurones are those  $\psi$  neurones which are capable of only very little quantitative cathexis...' To start with these were the neurones which 'generated consciousness,' as they fulfilled the necessary conditions for it, that is 'minimal quantities and faithfully transferred qualities.' They were placed in the following order:  $\phi\psi\omega$ . But in his new schema Freud clearly changed their place:  $\phi\omega\psi$ .

him recognized, ‘highly complex thought- structures are possible without consciousness playing any part in them’.<sup>78</sup>

Lacan applauded Lagache for ‘denouncing... the falsification’ that Heinz Harman and the rest of the ego psychology troika, Ernst Kris and Rudolph Loewenstein ‘tried to impose on history’ as they claimed that Freud had not shown an interest in the ego as an agency ‘the only agency the same agency as the one he continued to promote afterward, in the middle period of his work (in Freud II, 1914-1918), when he introduced narcissism. In ‘The Introduction of Narcissism’ (1914c) Freud inserted narcissism as a stage necessary for the emergence of the ego (*Ich*) as a libidinal object. Lacan, on the other hand, found a confirmation of his theory of the imaginary, the ego (*I*) formed during the ‘Mirror Stage’.<sup>79</sup> The ego psychologists who considered Freud’s first topography as physiological, and warned against the ‘anthropomorphic danger’ of the second topography, could not accuse Lacan of foolishness for his underlining the inconsistencies of the second topography, and more than that, when they try to force it as a genetic and structural model ‘this dummy . . . this thirty-six legged calf . . . this monster whose fictive seams evoke a collage devoid of artistry. . .’, a criticism he is glad to share with Lagache.<sup>80</sup>

---

<sup>78</sup> Freud, S., (1900a), S.E. 5, 615-616. Freud discussed consciousness again in ‘Beyond the Pleasure Principle’ (1920g). Consciousness and Perception were assigned a ‘position in space’ between outside and inside: ‘What consciousness yields consists essentially of perceptions of excitations coming from the external world and of feelings of pleasure and unpleasure . . . from within the mental apparatus.’ ‘Nothing daringly new there’, as he notes. Freud’s view was that consciousness cannot hold any permanent traces after the excitations have passed. In other words, memory and consciousness were incompatible (Freud, S., op. cit., S.E. 18, 28-29). It was something already underlined in the ‘Project’ (1950 [1895]).

<sup>79</sup> Cf.: this thesis, this chapter, p. 225

<sup>80</sup> Lacan, J., *Ecrits* (1966), p. 546, note 5.

After clearing the ground for his own contribution, Lacan expressed his disagreement with the role given to ‘inter-subjectivity’ in the structuring of personality by Lagache, but not without underlying other points they share in common. They both rejected ‘the idealists views of the genesis of the personal world from personal consciousness’, but, Lagache seemed to have forgotten that Piaget, the experimental psychologist whom he admired and used as a source, ‘accustomed us to study the genesis of the shared world in individual consciousness, going so far as to include the categories of scientific thought in it?’<sup>81</sup>

Lacan rejoiced in Lagache’s formulation: ‘before existing in himself, for himself, and through himself, the child exists for and through other people.’<sup>82</sup> It was the same as what he professed, when he said that ‘the unconscious was the discourse of the Other.’

The child coming to existence first through another (*par autrui*) and for another (*pour autrui*) stroke a cord with Lacan as it confirmed his hypothesis about the importance of the Word in human development. Indeed an ‘incarnation’ – a term Lagache used- took place at around the sixth month of gestation, when the unborn baby’s first physical manifestations started which as Lacan remarked, coincided with the moment adults start talking around him and about him.<sup>83</sup> This was enough proof of the precedence, at least logical, of the symbolic, which of course resounded in a term such as the ‘incarnation’ of prenatal existence (‘being for another’ of Lagache). Nevertheless, Lagache did not take stock of the

---

<sup>81</sup> Ibid., 547.

<sup>82</sup> Cf. this thesis, this chapter, p. 207

<sup>83</sup> That the child is ‘a pole of expectations, attributes and projects’, as Lagache said, is for Lacan equivalent to what he articulated about the subject’s coming to existence through the signifiers of the Other. While the relation with its surroundings remain hidden from the unborn baby, a lot of attributes are known already and bestowed on him by the others, such as the name it will take or the place in the line of descendents, and identifications to parents (ego ideal) or grand-parents (superego). (Lacan, J., op. cit. 547).

anteriority of the Other and followed a developmental line from the subject's primary differentiations to his identifications. His inter-subjective relations were simply relations to fellow others. It was 'the imaginary dimension which was deployed here.' For Lacan those 'primary differentiations' were 'suspended on the signifier' and if they were 'object relations,' they were 'object relations in the real'.<sup>84</sup>

Lagache argued that from the beginnings of individual existence, apparatuses of autonomy ensured a level of satisfaction of needs and drives and an adjustment to the environment. Lacan underlined how with the addition of demand, need became drive and the subject entered the real:

'Demand must be added to the need that sustains this primal differentiation, for the subject (prior to any 'cognitive structure') to make his entrance into the real, while need becomes drive, insofar as its reality is obliterated in becoming the symbol of a love satisfaction.'<sup>85</sup>

Lacan's structures of *need*, *demand* and *desire* replace the use of developmental terms such as 'syncretic participation', 'learning' and 'maturation', which Lagache used.

*Projection* and *introjection* were the modes of an asymmetrical relation to the other, the former imaginary and the latter symbolic, Lacan underlined.

---

<sup>84</sup> Lacan considered the first relations of the infant to the mother as real, happening before her absence acquires a meaning. This is not just a developmental line but a fact of the structure, as he argued. For example autistic or schizophrenic subjects show such 'object relations in the real' (Soler, C., *L'inconscient à ciel ouvert de la psychose*, Presses Universitaires du Mirail, 2002).

<sup>85</sup> Lacan, J., op. cit., 548. Lagache said that one cannot deny the newly born baby some 'conscious experiences,' although he thought it functioned 'without a proper cognitive structure.' By proper 'cognitive structure' Lagache meant a separation between subject and object, 'an awareness of the object as object', which did not yet exist at that stage.

‘The drama of the subject in the Word is that he experiences his want-to-be [*manque à être*] there, and the psychoanalyst would do well to define certain moments of it; for the psychologist cannot do anything about it with his questionnaires, and even his recordings, where these moments will not show up so fast –not until a film has managed to capture the structure of lack [*faute*] as constitutive of the game of chess. It is because it wards off this moment of lack [*manque*] that an image assumes the role of bearing the full brunt of desire: projection, an imaginary function. Contrary to this, an index is instated at the heart of being to designate the hole in it: introjections, a relation to the symbolic.’<sup>86</sup>

As Roudinesco pointed out,<sup>87</sup> a lot of Lacan’s early theories of the years 1936-1949, such as his Encyclopaedia article on ‘The family’ (1938), make us think of the Kleinian theories of the unconscious, identification and object relations. But Lacan was not yet acquainted with Klein’s work. On the other hand, Lagache was to a great extent an ‘object relations’ theorist, and his conception of projection and introjection as symmetrical relations to the object, was consistent with his Kleinian roots.

The subject simply learns from the other ‘to treat himself as an object,’ as Lagache said. Then the object becomes ‘transcendental.’ But for Lacan the subject emerged from the signifiers that were handed to him by the Other and which were placed in the Other as their ‘transcendent locus’:

‘Thus it is hardly necessary for the “subject-ego” to push back the “object-ego” in order to make it “transcendent” for himself; rather, the true, if not the good subject, the subject of desire – seen in the light of fantasy and in its hiding place beyond his ken – is nothing other than the Thing, which in and of itself is what is closest to him while escaping him more than anything else.’<sup>88</sup>

---

<sup>86</sup> Lacan, J., op. cit., 549.

<sup>87</sup> Roudinesco, E., (2001) Jacques Lacan, *The Mirror Stage*, Lecture given in the ‘*Bibliothèque Nationale de France*’, in the year 2000 and published in Paris, in 2001.

<sup>88</sup> Lacan, J., op. cit., 550. Lacan plays with the equivocation between *où ça* and *oussia* (ουσία), the Greek for essence.

## H. “where is id?”(où ça?)

Lagache questioned the subject in terms of ‘personal structure’, -he did this by questioning the three systems, ego, id, superego- in order to find ‘the whole person’ there. Each one of the systems was found to be lacking, but Lagache promoted the ego as the one that had the capacity to bring out ‘a unity of being.’ Despite the ‘demolition’ of the ego’s unity in pre-freudian psychiatry and psychopathology and even in Freud himself, as Lagache had argued, he saw the necessity to encourage the ego’s relative autonomy in the treatment. His examination of the ‘id’ presented a special interest. He attempted to situate the subject there, as Lacan noted, but that led to an impasse. He wanted the id to be a structure, and met with a series of ‘paradoxes’ in the id’s organisation or rather in its lack of organisation, as a result of the special characteristics which Freud had attributed to the Unconscious, and then to the id, its successor in the second topography.<sup>89</sup>

The first of these paradoxes was that the id was rather unorganized, it contained both a sort of disorder, ‘the drive representatives, unconscious impulses’, the indestructibility of desires and the automatic (orderly, therefore) nature of repetition, which Freud had called *Wiederholungszwang*’(compulsion to repeat), arising from the repressed. The second paradox was the absence of negation, and the absence of contradiction amongst the drives, although Freud mentioned other mechanisms (defences) of ‘inhibition, deferral, and representation by the opposite.’ The third paradox was the silence of the drives (especially

---

<sup>89</sup> Freud described the *Ucs.* system as ‘having no negation, no doubt, no degrees of certainty.’ (‘The Unconscious’, 1915e, S.E. **14**, 186.) The processes of the system *Ucs.* were ‘timeless,’ paid ‘just a little regard to reality... were subject to the pleasure principle’ To sum up the special characteristics of the unconscious were: ‘*exemption from mutual contradiction, primary process (mobility of cathexes), timelessness, and replacement of external by psychical reality*’ (op. cit., 187).

the death drives as Freud said in ‘The Ego and the Id’), despite the fact that there was a whole cacophony of them when the patient started talking in the treatment.

The structure of the id, as put forward by Freud, did not provide for any differentiation between *primary needs* (of the organism) and *secondary processes* of inhibition, negation, delay and postponement, even if Freud brought some corrections to that later. It was there that Lacan found the use and function of the signifier as indispensable for these differentiations, for example, between need and desire.

It was the ‘irreducible materiality of the signifier’ we saw operating in the structure of language and therefore in the unconscious, both their synchrony and diachrony, orderly and disorderly succession, simultaneous existence. Mixed as the numbers in a lottery, from which we chose apparently randomly to place bets which have to do with our destiny. Despite their disorder (synchronicity), a great and indestructible order subsists (diachrony).

They have the force of an oracle, as Lacan put it:

‘Let us consider the signifier quite simply in the irreducible materiality that structure entails, insofar as this materiality is its own, and let us conjure the signifier up in the form of a lottery. It will be clear that the signifier is the only thing in the world that can underpin the coexistence – constituted by disorder (synchronically) of elements amongst which the most indestructible order ever to be deployed subsists (diachronically).’<sup>90</sup>

Any exclusion in the order of signifiers is a confirmation, any negative sign is a positive one. Lacan asserted that Freud led us to the signifier, with his ‘Five Clinical Cases’, ‘The

---

<sup>90</sup> Lacan, J., *Ecrits*, 1966: 551.



Interpretation of Dreams' (1900a), 'Psychopathology of Everyday Life' (1901b), or the laws of grammar which he organized for the drives. The drives have a structure. They are not signifiers, but they are 'structure'. Lacan suggested that Freud's statement about 'the silence of the drives' loses its opacity if we think of a gap such as a letter box, which is silent but full of letters coming from the outside like for example those thrown in the '*bocca di leone*' in Rome. The id is that sort of reservoir, or rather reserve of letters which await their articulation. There lies the meaning of the death drive for Lacan, not as silencing the subject but rather as allowing him to speak one day.

Another error of Lagache was to confuse certainty with assertion. Although we can say with Freud that there is no degree of certainty in the unconscious, we can also adopt Lacan's statement that the only certainty for the subject is the assertion of his act.

Taking Freud's initial statement about the absence of negation in the id/Unconscious, Lagache had not found any affirmation either, and thus got rid of Freud's fundamental hypothesis of affirmation (*Bejahung*) as 'the first moment of unconscious enunciation' preceding any negation. Affirmation is an important manifestation of the subject, which does not need to be vigilant or conscious to be there; it is present, for example, in the randomly chosen number in a lottery. Lacan referred to Freud who gave us numerous examples in his 'Psychopathology of Everyday Life' (1901b).<sup>91</sup> As he put it: 'It is in the signifier's foundational duplicity that the subject finds first the hidden stream in which it flows before seeping out – we shall see through which crack.'<sup>92</sup>

---

<sup>91</sup> Ibid., 553.

<sup>92</sup> Ibid.

Lagache rejected the idea that the id was simply a reservoir of the drives; he defined it as ‘the reservoir of object relations’.<sup>93</sup> Here it is important to remember that in ‘The Ego and the Id’ (1923b) Freud had already talked of ‘the id’s object cathexes.’ But Lagache supposed them as submitted to ‘condensations’ and ‘syncretism’, and posited that the subject was scattered amongst the drive, the aim and the object, ‘dispersed between the different object relations’.<sup>94</sup> He concluded that this proved the absence of a ‘coherent subject’ in the id, which defined the id’s organization or better its lack of organization:

‘The defensive and repressive operation excludes the drive from the coherent ego and sends her back to a kind of non-ego, internal and ignored...What we can say about the drives of the id is that they exist’, and that they exist in themselves, on the impersonal mode.’<sup>95</sup>

But the offshoots or representatives of the drives in the ego, as Lagache added, made them accessible. He reminded that Freud often said that the drives were the ‘demand’ of the body on the psychical apparatus for work. Consequently, ‘the drive’s representative questions the ego, puts the ego into question’. The answer affirmative or negative is an ego operation, a ‘foundation of its autonomy and unity’.<sup>96</sup>

On the contrary, as we said above,<sup>97</sup> Lacan found the subject in the id; that it functions there in the ‘impersonal’ mode or that it is ‘incoherent’, or ‘unconscious’ does not make it less of a subject. He finds it in the randomly selected numbers of the lottery: ‘for the

---

<sup>93</sup> Cf.: This thesis, this Chapter 4, p. 210. Lagache D., (1961[1958]), 206.

<sup>94</sup> Cf.: Ibid.

<sup>95</sup> Cf.: This thesis, this Chapter 4, p. 211; Lagache, D., op. cit., 207.

<sup>96</sup> Ibid.

<sup>97</sup> Cf.: This thesis, this Chapter 4, ibid.

subject is found here simply by virtue of the fact of having slipped into this number by the decimal presence that sums up in two columns what merely constitutes its cipher. . . ’<sup>98</sup>

Where Lagache placed the drives [as object relations], Lacan placed the letter, or the randomly selected number. ‘Jokes and their Relations to the Unconscious’ (1905c, *Der Witz und seine Beziehung zum Umbewußten*) showed one of those cracks the subject found in order ‘to seep out’ of the hidden stream of the unconscious: ‘It is in the signifier’s foundational duplicity that the subject first finds the hidden stream in which he flows before seeping out- we shall see through which crack.’<sup>99</sup>

The unconscious was canny and assertive, while the drives proliferated with language. Thus, Lacan found problems in Lagache’s felicitous expression ‘the id’s interrogation that calls the ego into question, or even puts it “to the question.”’ ‘The question cannot come from the id’, Lacan said, but rather from the ego responding to the id, defending itself against the assertiveness of the id and answering the drives with the agitation of anxiety: ‘We have known, however, since *Hemmung, Symptom und Angst* [‘Inhibitions, Symptoms and Anxiety’] that the most characteristic agitation in the ego is but a warning sign that brings into play the defense . . . against the id’s assertiveness, not its question.’<sup>100</sup>

In attributing the function of judgement to the ego, Lagache wanted to restore its autonomy and unity. Lacan reminded Lagache that Freud had distinguished a ‘fundamental form of judgement’ which was first in the unconscious before any secondary judgement was

---

<sup>98</sup> Lacan, J., *Ecrits*, 1966: op. cit. 553.

<sup>99</sup> Ibid.

<sup>100</sup> Op. cit., 554.

constituted. Freud called it ‘primary judgement’. ‘Primal judgement’, as Lacan put it, ‘is already constituted at the level of the system of the first breaches [*frayages*] of pleasure.’<sup>101</sup>

Is it there that ‘the drives come to exist’, as Lagache put it?

‘The drives *ex-sist* in the sense that they are not there in their place, that they present themselves in this *Entstellung*, in this de-position, so to speak or, as it were, in this crowd of displaced persons. Does this not also give the subject his chance to exist some day? For the true being, however this chance seems compromised. For the way things are going ... when language gets in on the act, the drives must multiply instead, and the question would rather be how the subject will find any place there at all.’<sup>102</sup>

The answer comes ‘in the hole the subject makes for himself there’, added Lacan.<sup>103</sup>

## I. Lacan found the subject in negation

At this point it is useful to refer to Brentano as a serious influence on Freud’s ideas about judgement, and it is known that Freud attended Brentano’s seminars in Vienna in the early years of teaching (1874-1876)<sup>104</sup> and perhaps in 1889, when Brentano explored the origins of moral knowledge, and the correctness of judgement. Brentano based his theory of judgement on the original affirmation (*Bejahung*). Freud distinguished two sorts of

---

<sup>101</sup> Ibid. Freud’s first developments on the act of judgment and the distinction between primary judgment as a ‘judgment of attribution’ and reproductive thought as a ‘judgement of existence’ in the ‘Project’ (1950a [1895], Part I, [16], [17], [18]): ‘Judging is a method of proceeding from the perceptual situation that is given in reality to the situation that is wished for . . . Primary judging seems to presuppose a lesser influence by the cathected ego than do reproductive acts of thought . . . Judging thought operates in advance of reproductive thought...’ (S.E. 1, 332-333). ‘Thus the secondary process is a repetition of the original  $\psi$  passage of quantities at a lower level, with smaller quantities.’ (Ibid., 334).

<sup>102</sup> Ibid.

<sup>103</sup> Ibid., 555.

<sup>104</sup> Many of Brentano’s lectures appeared in his best known work: ‘Psychology from an empirical point of view’ (*Psychologie vom empirischen Standpunkt*, 1874). Freud followed Brentano’s lectures on the history of philosophy, logic and Aristotle, from 1874 to 1876 (Jones, E. , *Sigmund Freud, Life and Work* (Vol. I, 1953, II, 1955, III, 1957) and perhaps later again.

judgement, ‘primary judgement’ which he defined as ‘judgement of attribution’, seeking identity between a perception and a wishful representation, and a secondary judgement, a ‘judgement of existence’ which was about ‘the cognition of an object,’ as he had said already in the ‘Project’ (op. cit., 334). For that second form of judgement he used the concept of ‘Negation’ (*Verneinung*) later.<sup>105</sup>

Lacan, on the other hand, underlined the importance of those two mechanisms in the appearance of the subject and paid special attention to Freud’s approach of negation as a privileged mode of appearance of the subject. Thus, as he pointed out, we find the subject in the negative particles of language, such as the French ‘*ne*’ in the phrase: *je crains qu’il ne vienne*, ‘I am afraid he may come’, which also conceals a desire that he does not (this is what the expression implies in French, and this is why the verb following the negative particle is put in the subjunctive mode). The difference between statement and enunciation is clear in this example, as *Je, I*, is not the subject, but only the shifter of the sentence:

‘The subject of enunciation, insofar as his desire breaks through, lies nowhere else than in this *ne* whose value can be found in a form of haste in logic - “haste” being the name I give the function to which its use is tied in the phrase, *avant qu’il ne vienne* [before he comes].’<sup>106</sup>

‘*Ne*’ evokes ‘a trace that is effaced along the path of a migration, more precisely of a puddle that brings out its outline.’ Could it be that the earliest signifier of negation was the ‘elision of a signifier?’ As an example we have, in Freud’s analysis of the Wolfman, his

<sup>105</sup> ‘The function of judgment is concerned in the main with two sorts of decision. It affirms or disaffirms the possession by a thing of a particular attribute; and it asserts or disputes that a representation has an existence in reality.’ (Freud, S., 1925h, S.E. **19**, 236).

<sup>106</sup> Lacan, J., *Ecrits* (1966) and *English* (2006), 556. Lacan made an extensive commentary on J. Hypolitte’s reading of Freud’s ‘Negation’ in his Seminar ‘Freud’s Papers on Technique’ (Book I, 1953-1954), February 10, 1954. This intervention figures also in the *Ecrits*, 308.

comments on his *Espe* : ([W]espe). So, Lacan asks: ‘Do the prefixes of negation merely indicate the place of this signifying ablation by occupying it anew?’<sup>107</sup>

At that point in his ‘Remarks’ Lacan referred to a graph he was constructing that year in his Seminar *The Formations of the Unconscious* (1957-1958, Book V), and completed the following year in *Desire and its Interpretation* (1958-1959, Book VI, non published). On it he placed the subject on two distinct levels: on the upper level the ‘subject implicit in pure discourse’, level of the [unconscious] enunciation (*énonciation*), and on the lower level the chain of statements (*énoncés*), where the subject is only designated ‘by shifters’ (‘I’).<sup>108</sup>

Graph 1: The ‘button tie’ (*point de capiton*)

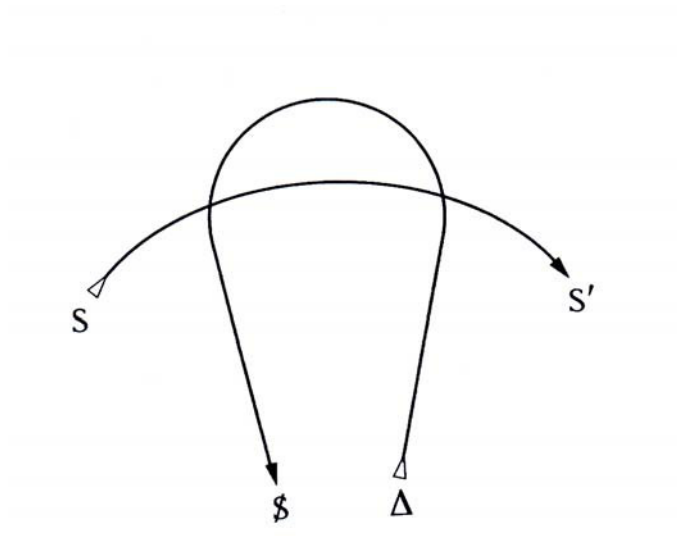

Lacan, J, *Ecrits*, op. cit., p. 681

<sup>107</sup> Lacan, J., op. cit., 557.

<sup>108</sup> Op. cit., 556. Lacan’s developments on the Graph of Desire appeared first in ‘*Subversion of the subject and Dialectic of Desire*’, Op. cit., Graph 1 , 681, Graph 2, 684, Graph 3, 690, Complete Graph., 692.

Here the signifying chain's vector  $S.S'$  is intersected in two points by the retrograde movement of  $\Delta$ , desire, stopping 'the otherwise indefinite chain of signification.' A subject is born at the stopping point, but poignantly this subject who was not divided to start with, will become so at the end of the signifying process,  $\$$ .

Graph 2

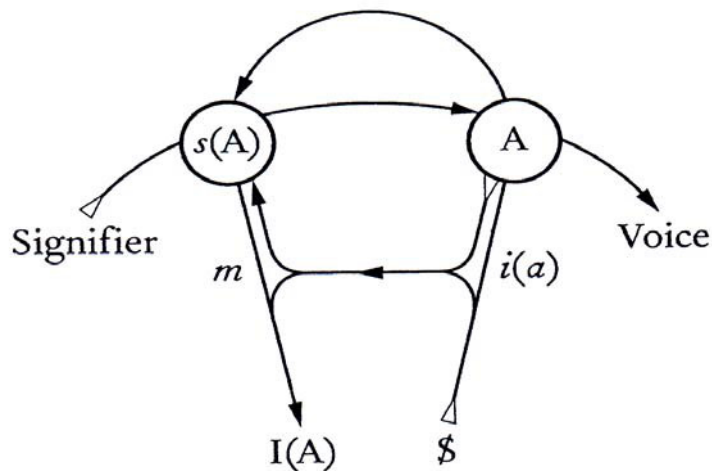

Lacan, J., *Ecrits*, op. cit., 684

Here we have again the lower level, the level of the deployment of the signifiers but what is now happening is that with the advent of speech, the subject receives from the place of the Other (A), who is the locus of truth, his message or signification, his first alienating identification,  $I(A)$ , the ego ideal, as his starting point while the divided subject,  $\$$ , moves from the vector's end point to its starting point. The vector Voice- $\rightarrow$ Signifier is retrograde. 'This is a retroversion effect by which the subject, at each stage, becomes what he was to

be...before that, and that “he will have been” is only announced in the future perfect tense.’

(ibid.)

Graph 3

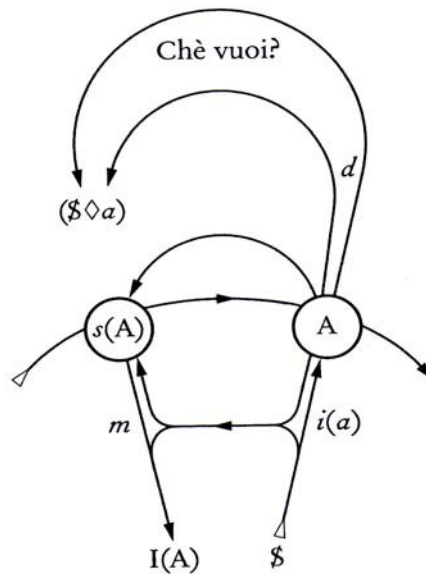

Lacan, J, *Ecrits*, op. cit., p. 690

Graph 3 is closer to the complete form of the Graph of Desire (see below p. 236). A question mark appears in the form of a hook on the upper level of the unconscious enunciation, the subject's demand concerning his desire. The hook is deployed from the place marked (A), the Other, and concerns the subject's desire. The implicit demand of the subject in the upper level is ‘what does the Other



want?', the Other returns the question to the subject 'what do you want?' which 'leads the subject to the path of his desire', but, as Lacan adds: 'assuming that thanks to the know-how of a partner known as a psychoanalyst, he takes up that question...in the following form: "What does he want from me?"'

### The Complete Graph of Desire

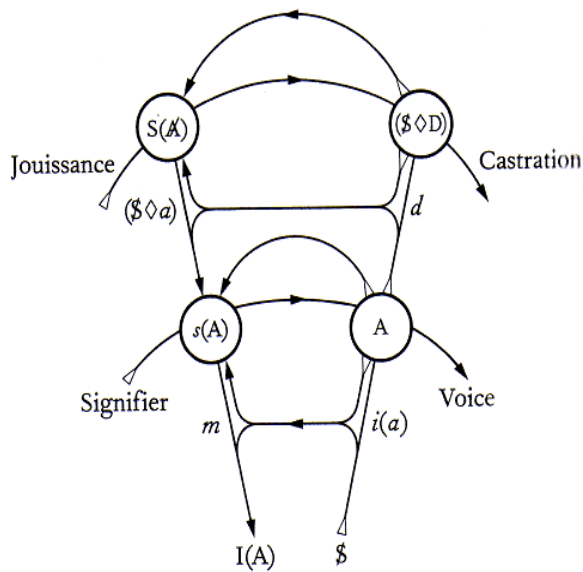

Lacan, J, *Ecrits*, op. cit., 692

As Lacan explains 'what the graph now offers is situated at the point at which every signifying chain takes pride in closing its signification.'  $S(\bar{A})$  signifies the lack in the Other, lack is constitutive of the Other too, as from the treasure of signifiers one is missing, making the Other incomplete. In this level,

which is the level of the signifiers of the drive, there is no absolute truth, the Other does not know, and the analyst who is in this case ‘his mouthpiece’ ... ‘need not answer for any ultimate truth’, because ‘there is no Other of the Other’ as Lacan put it. There is one thing that the Other does not know, sexual difference and desire.

### **J. What articulation between defence and the subject, and where is the drive?**

The relations between the emergence of the subject in the structure (of language), which Lacan had shown on the graph, plus the link between desire and defence made apparent the cacophony of those analysts who researched the defence mechanisms:

‘To outline the relations between the subject and structure – structure being understood as the structure of the signifier – is to restore the very possibility of the effects of defence . . . What I say is that no suppression of the signifier . . . can do anymore than free from the drive a reality which, however slight the importance of need may be in it, will merely be all the more resistant because it is a remainder’<sup>109</sup>

Thus ‘defence creates its effect by another pathway, modifying not the tendency but the subject.’<sup>110</sup> The subject will first emerge from the effects of defence as a ‘signifying elision’, as the initial ablation of a signifier, ‘the matrix of *Verneinung* (negation)’, which ‘asserts the subject negatively by preparing the void in which he finds his place.’ Therefore, the subject could be said to reside in the enlargement created by the cut in the signifying

---

<sup>109</sup> Ibid. 557.

<sup>110</sup> Lacan, J., *ibid.* 558. By tendency Lacan means the drive. It is something similar to what Freud argued, that repression affects the drive’s representative only; ‘The Unconscious’ (1915e), S.E. **14**, 177.

chain. This is his ‘locus.’ This cut is enlarged with negation, and perhaps we can say that it becomes even more enlarged with other modes of defence.<sup>111</sup>

Already in the ‘Project’ we found defence as a function of *Ich* (ego), and Freud came back to the idea in one of his last works, the posthumously published short text ‘The Splitting of the Ego in the Process of Defence’ (1940e [1938]) (*Die Ichspaltung im Abwehr Vorgang*).

In his ‘Remarks’ [1958]) Lacan was not satisfied with what Lagache had said about the subject, first that it ‘is not distinguished from the drive, from its aim and object’ and second that it is ‘dispersed among these different object- relations or their *groupings*,’. Instead, there was another possibility, a multiplicity without ‘grouping’, a ‘shimmering of Whole-Ones (*Tout-Uns*)’ and without a fixed place in the range.<sup>112</sup>

In Lagache, there was an ideal of unity, an ideal of coexistence between the subject as knowing and the object as known – while the whole analytic experience proves the contrary, its division and fragmentation; and that there is ‘no coherent subject’ in the id, as Lagache concluded, this was the subject’s most ‘natural’ defence. Here, in the circle cleared by ‘the burning brush of the drives’, the other agencies ‘can set up their defences’, and first, the subject. Lacan marks this place as a place of an initial absence, where ‘each and every thing is called to be washed of sin [*faute*]. . . ‘for everything might not exist in the first place . . . to be or not to be’,

---

<sup>111</sup> Ibid.

<sup>112</sup> Ibid.

‘ . . . we must articulate that the judgment of existence can only found reality by ‘raising reality up’ (*relever*) from the precarious status it has when this judgment receives it from a previously made judgement of attribution.’<sup>113</sup>

Here Freud’s ‘*Wo Es war, soll Ich werden*’ resonates, but not in the way it was interpreted by the ego psychologists or Lagache. In his Lecture XXXI of the ‘New Introductory Lectures’ (1933a), ‘The Dissection of Personality’ (*Die Zerlegung der Persönlichkeit*) Freud wrote:

‘After all, the ego is in its very essence a subject; how can it be made into an object? Well, there is no doubt that it can be. The ego can take itself as an object, can treat itself like other objects, criticize itself, and do Heaven knows what with itself. In this, one part of the ego is setting itself over against the rest. So the ego can be split.’<sup>114</sup>

Freud talked there of the ‘division of personality’ but of course without ‘sharp frontiers’, rather resembling the colour areas of a painting and argued that in the course of their development they may differ from one individual to the other, and sometimes merge again. In the psychoanalytic treatment a sort of re-union between the psychical systems was desirable. ‘After making the separation [between ego, id, superego], we must allow what we have separated to merge together once more.’<sup>115</sup> Freud referred to the results of some mystical – healing - practices and the way they operated, ‘upsetting the normal relations between the different regions of the mind’, but that was not the path of psychoanalysis, and it was doubtful if that road ‘will lead us to the ultimate truths from which salvation is to be expected’.<sup>116</sup> The intention of psychoanalysis - more prosaic, in a sense - was:

‘ . . . to strengthen the ego, to make it more independent of the superego, to widen its field of perception, and enlarge its organisation, so that it can appropriate fresh portions of

---

<sup>113</sup> Ibid., 559.

<sup>114</sup> Freud, S., (1933a), Lecture XXXI, S.E. 22, 58.

<sup>115</sup> Ibid., 79.

<sup>116</sup> Ibid., 80.

the id. Where id was there ego shall be. It is a work of culture- not unlike the draining of the *Zuider Zee*.’<sup>117</sup>

In ‘The Freudian Thing’ (*Ecrits*, 1966[1955]),<sup>118</sup> Lacan analysed that sentence. He underlined that Freud had not written ‘das Es’ or for that reason, ‘das Ich’, but only *Es* and *Ich*; these were not the two instances of the second topography, but two different places, *Es*: a place of being, *Ich*, a place for the subject to come to light: ‘where id, *ça*, - was, (*ç’était, s’ était –*), the subject of the unconscious –, it is my duty that I come into being.’<sup>119</sup>

When Lacan applied Freud’s sentence to the optical schema in ‘Remarks’ (1960[1958]), he insisted that the Other of discourse was not absent ‘from any distance that the subject achieves in his relationship to the other’, therefore intersubjectivity was a false principle. There is always a ‘triangulation’, the subject, the Other, the little other, and discourse -the place of the Other, which is always latent in triangulation- ‘is not latent as long as it extends all the way to the purest moment of the specular relation.’<sup>120</sup>

As for the subject ‘it was’ (*ç’était*) – not ‘dispersed between the drive and the object relations’, as Lagache had put it, but came in ‘an empty place’, a place which ‘demands that the nothing [*le rien*] becomes the core of creation’, becomes the place of something, the place of the possibility of being, of the ‘want-to-be’. The subject’s ignorance of the real -

---

<sup>117</sup> Ibid.

<sup>118</sup> His 1955 lecture to the Vienna Neuropsychiatric Clinic, published later in the *Ecrits*, op. cit., 334-363.

<sup>119</sup> ‘*Là où ç’ était, peut-on dire là où s’ était, ... c’ est mon devoir que je vienne à être.*’ Lacan, J., ‘The Freudian Thing’, *Ecrits*, op. cit., 347-348. *S’être* would signify the place of absolute subjectivity.

<sup>120</sup> Lacan, J., ‘Remarks on Daniel Lagache’s Presentation’ (*Ecrits* , op. cit., 568. This refers to the moment the child turns back to the adult who is holding him and appeals to him as a witness. This witness who verifies the image, he empties it at the same time from its charm, from the ‘jubilant assumption in which it certainly already was (the subject).’

that empty place which Lacan will later define as a hole- makes possible the desire to be. No supreme being is required there, it is the place of 'No One Anymore' (*Ou de eis*, Ulysses's reply to Polyphemus). To the question 'what is this, (*Was ist das*), the answer is 'it is' (*est-ce*), an impersonal answer which comes from elsewhere . . .' <sup>121</sup>

### K. Lacan's Optical Schema

The substitution of 'eye' for 'I' (*je*), the aggressive confrontation between two *I*s (egos), as in the story of Ulysses and Polyphemus, evoked by Lacan in his analysis of *Wo Es War*, prepared the grounds for introducing the optical schema, where ideal ego, *i'(a)* and *i(a)*, libidinal ego, find their distinct places, the former identifies to the ego ideal (*I*), which comes in the place of the subject (symbolic place). Virtual image, ideal ego, [*i'(a)*] takes the place of the libidinal ego, while the libidinal ego, the body and its objects, the real image [*i(a)*] of it, becomes inaccessible to the subject. <sup>122</sup> The confusion of these two spaces, symbolic and imaginary, was characteristic of the imaginary function.

'The Mirror Stage' (1949) was a particular case of the imaginary function, insofar as it first established a relation between an *Innenwelt* and the *Umwelt*, the organism and its reality,

---

<sup>121</sup> Ibid., 559. From the 'no one there to answer' we can be lead to a more terrifying answer, where 'a more cunning Ulysses tricks on another Polyphemus (a fine name for the unconscious) with superior derision by getting him to demand to be nothing, at the same time as he proclaims he is a person [*personne*], before blinding him by giving him an eye.'

<sup>122</sup> 'For my distinction between the space cleared out for the subject without him occupying it and the ego that finds lodgings in that space resolves the majority of the aporias outlined by Lagache . . .' (ibid.)

the subject with the function of *imago*.<sup>123</sup> ‘The jubilant assumption [*assomption*] of his specular image,’ which the infant -between the age of six and eighteen months- experiences, when he recognises his own image in the mirror, ‘still trapped in his motor impotence and nursling dependence’, was ‘the symbolic matrix’ in which a primordial *I* was precipitated, ‘prior to being objectified in the dialectics of identification with the other, and before language restores to it, in the universal, its function as a subject.’

‘It suffices to understand the mirror stage as an *identification*, in the full sense analysis gives to this term: namely, the transformation that takes place in the subject when he assumes [*assume*] an image - an image that is seemingly predestined to have an effect at this phase, as witnessed by the use in analytic theory of antiquity’s term “*imago*”.’<sup>124</sup>

The primordial *I* which Lacan then called the “*ideal-I*” (*je-ideal*),<sup>125</sup> was not only the image of the body, but it included the ‘statue’ in which man would alienate himself. This ‘*imago*’ in the old sense symbolized ‘the ego’s mental permanence.’<sup>126</sup> It had the power of a ‘mirage’; it united with other Gestalten, in which man alienated himself, to form the ‘automatons’ which dominated him, not only in dreams and hallucinations and in the appearance of the double, but also in the images of the little other which constituted human knowledge as paranoiac.

---

<sup>123</sup> The presentation of ‘The Mirror Stage as Formative of the *I* Function’, took place at the 16<sup>th</sup> International Congress of Psychoanalysis, in July 1949. Lacan gave a whole new interpretation to an already known psychological experiment, ‘the illuminative mimicry of the *Aha Erlebnis*’, the experience of jubilation of the infant in front of the mirror when he is able to recognize his own image, which psychologists Köhler and Baldwin had first observed (they considered it to express ‘situational apperception, an essential moment in the act of intelligence’ (op. cit., 75). Even today the experience of the mirror of little toddlers attracts interest amongst researchers in developmental psychology with regards to its relation to intelligence and the beginnings of memory.

<sup>124</sup> Ibid., 76.

<sup>125</sup> Lacan never used the term *Je-ideal* again.

<sup>126</sup> Lacan will use the term ‘symbolic effectiveness’ for these imagos, which was the title of the essay by Claude Lévi-Strauss published equally in 1949.

‘Indeed, for imagos -whose veiled faces we analysts see emerge in our daily experience and in the penumbra of *symbolic effectiveness*- the specular image seems to be the threshold of the visible world . . . ’<sup>127</sup>

These alienating Gestalten had pushed Lagache to the ‘personalistic’ direction, these ideal-egos were mirages to which Lagache had given a consistency.

The ‘optical schema’ was first presented by Lacan to illustrate Freud’s theory of narcissism and what happens in the analytic treatment when speech within transference intervenes in the structure. It was first presented in his Seminar ‘Freud’s Papers on Technique’ (1953-1954, Book I).<sup>128</sup> It was an experiment from Optics, known in early 20th century Physics as ‘the reversed bouquet of flowers.’<sup>129</sup> By developing it, he could show the articulation and sometimes confusion of the different spaces, real, imaginary and symbolic.

The optical schema was potentially a topological schema, because it delimited two distinct or to be precise three distinct and/or conjoint spaces. The first figure of it was based on Bouasse’s experiment with the curved mirror and the contraption of the vase and the flowers.

---

<sup>127</sup> Ibid., 77.

<sup>128</sup> Lacan presented it there as a way of dealing with the problem of ‘conjoining imaginary and symbolic’ without confusing them, and to explain the ‘constitution of the real’. It followed his critique of Melanie Klein’s theory that the objects were constituted as real by a series of imaginary substitutions, incorporations, expulsions, projections, and re-introjections, which she qualified as ‘*symbols*’. Lacan opposed such a conception of the symbolic which led straight to the reign of the imaginary.

<sup>129</sup> The reversed bouquet of flowers’ was an experiment in optics which physicist Henri Bouasse published in his work ‘*Optique et Photométrie dites géométriques*’, 1934); ‘Le schéma optique, Miroirs-Spécularité’, *Cahiers de lectures freudiennes*, Lysimaque, 1987. It could be done both ways, but Lacan developed it as ‘the reversed vase’, which comes down to the same.



The curved mirror was the place from where the subject, which was in fact elsewhere, could see the image of the vase together with the flowers, the real image of his body (which in real space was inaccessible to the subject) as container of its objects. It is thus that he forms his ego.

‘It is because the lens comes to occupy the place from which the subject can look, and alights on the object-holder that is in fact focused on there when the subject looks from elsewhere, that he superimposes himself, to the great detriment of the whole, on what can come to be ogled there.’<sup>130</sup>

Thus the distinction between ‘the space cleared out for the subject without it occupying it and the ego that finds lodgings in that space’ disappears.<sup>131</sup> What Lacan showed with the mirror stage, and developed with the optical schema 1 was how the illusion of the ego was shaping a psychological reality where the imaginary prevailed. The problem could not be resolved by trying to correct the angle of the instrument, but by managing to see the contraption for what it was - an optical illusion. In optical schema 2 and 3, Lacan tried exactly that with the addition of a plane mirror - a mirror standing for the big Other than the analyst himself – to show the conjoining and split between imaginary and symbolic space, as well as the changes in real space, caused by a tilting of the mirror by 90 then 180 degrees, that is by a complete disappearance of the plane mirror, standing for the analyst’s silence. The split operated in real space behind the plane mirror during the two phases of its tilting explained phenomena such as the encounter with one’s own double, or the images of the mutilated body in dreams and hallucinations often met within the psychoanalytic treatment as a result of aggressiveness felt.

---

<sup>130</sup> Lacan, J., *Ecrits*, op. cit., 560.

<sup>131</sup> *Ibid.*, 559.

The laws of optics could serve as an introduction to the imaginary function: The basic precondition of optics was that ‘ . . . for each given point in real space, there must be one point and one corresponding point only in another space which is the imaginary space.’ <sup>132</sup>

There were real images formed under certain optical conditions, and those Lacan calls virtual or subjective, alternatively. They behave like real objects. There are also virtual images of real images.

‘Optical images possess a peculiar diversity –some of them are purely subjective, these are the ones we call virtual, whereas others are real, namely behave like objects and can be taken as such.’ <sup>133</sup>

In the contraption of Bouasse the vase and the bouquet of flowers, both real, but the former hidden underneath in an empty box, the other showing on top of the empty box were fused, thanks to the spherical mirror, to form a real image, a subjective phenomenon like seeing an oasis in the desert. This optical illusion corresponded to the illusion of one’s own ego as a unity, a mental permanence and a unified body image. The subject hidden amongst the flowers on this side of the curved mirror cannot observe his ego. He could have observed it as the real image if placed in the symbolic space above the mirror. But, of course this is not possible, as it would imply a real split of the subject. A mediation through a second mirror, a plane mirror interposed as the Other of discourse, is necessary in order to bring the subject’s real image amongst the flowers, but on the other side, behind the vertical mirror, in the imaginary space, where a virtual image is superimposed on the real image.

---

<sup>132</sup> Lacan, J., (1953-1954) Seminar Book I, *Freud’s Papers on Technique*, p 76.

<sup>133</sup> Ibid.

Thus, Freud's Figure 2 of the psychological apparatus in Chapter VII of 'The Interpretation of Dreams' (1900a) which marked the locus of the psychological reality as the Other Scene, the Unconscious, was transposed in the dream images as a subjective or imaginary reality:

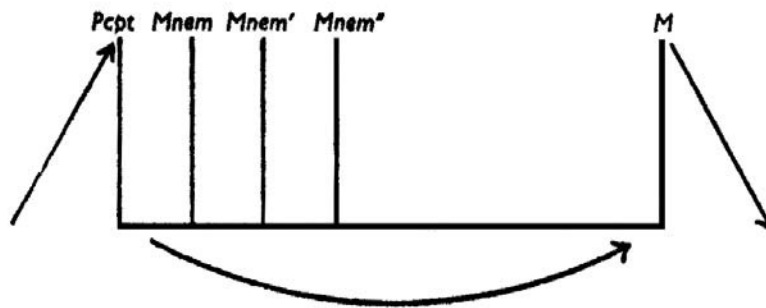

[Fig. 2], Freud, S. (1900a), S.E. 5, 538.

Psychical reality corresponds to a point inside the apparatus where one of the preliminary stages of an image comes into being.<sup>134</sup>

'What is presented to us in these words is the idea of a psychical locality- what is at issue here is precisely the field of psychical reality, that is to say of everything which takes place between perception and the motor consciousness of the ego'<sup>135</sup>

<sup>134</sup> In this schema, between the perceptive and the motor end of the apparatus, there is the field of unconscious memory traces, a field of psychical reality, a *psychical locality*, part of the whole structure which Freud compared to a 'reflex apparatus'. Cross-refer this thesis, Chapter 1, p. 76.

<sup>135</sup> Lacan, J., *Freud's Papers on Technique* (1953-1954), Seminar Book I, p.75. Lacan read a whole passage from Freud's 'The Interpretation of Dreams' (1900a), S.E. 5, 536, in session 24 Feb. 1954 of the Seminar.

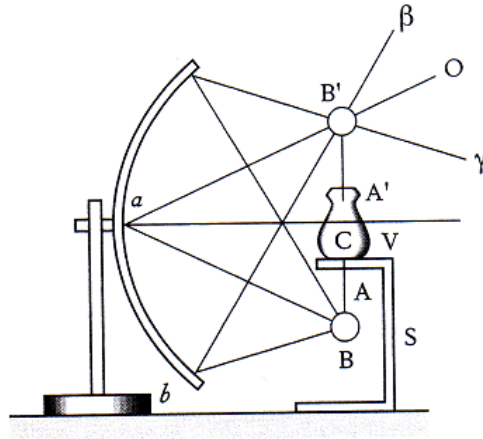
Optical Schema, Figure 1 <sup>136</sup>

With this schema Lacan shows how the optical illusion of the unified vase with the flowers (standing for the unified ego) is produced when the subject is placed opposite the curved mirror (here equivalent to the brain, or some cortical function).

<sup>136</sup> A vase, C, was placed on top of a half-open box, S, in front of a spherical mirror, at a certain distance. Inside the box was suspended a bouquet of flowers, A B. The mirror was placed in such a way that it produced an inverted real image of the flowers on the vase in A' B'. If someone was looking from the other side of the spherical mirror and from a certain distance, focusing on the vase while being within the cone of the reflected rays,  $\beta B' \gamma$ , he would see the real image of the bouquet, B' taken in the vase's neck, A'. (Bouasse, H., op. cit., 72; commented by Lacan, J., (2006), op. cit., 564).

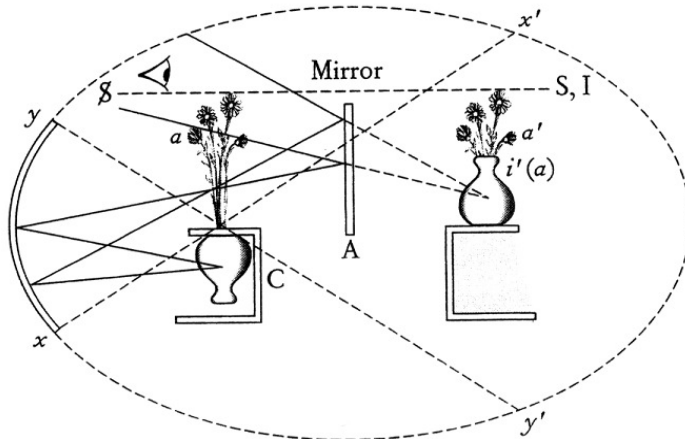
Optical Schema, Figure 2 <sup>137</sup>

Now, a plane mirror is placed in front of the spherical one, and between the two mirrors the contraction of the vase and the bouquet of flowers, now in the opposite order. The plane mirror represents the big *Other* (A). An observer (eye) placed between the flowers would be able to see the virtual image of the real image of the vase with the flowers in this plane mirror, under certain conditions. The observer, or ‘eye’ , has to be on this side of the spherical mirror, amongst the flowers but outside the cone of rays hitting the spherical mirror, so that the subject (\$) cannot see the real image in real space anymore (and this is why the real image of the vase is not represented in Optical Schema, Figure 2).

‘Now in order for the subject, \$, to see this image in mirror A, it suffices to have his own image (in the virtual space engendered by the mirror, and without it being necessary that he sees his image, for he might be outside the field orthogonal to the mirror’s surface; see Figure 2 and the dotted line, \$S) come, in real space (to which the virtual space

<sup>137</sup> Op. cit., 565.

engendered by a plane mirror corresponds point for point), to be situated inside the cone that delimits the possibility of the illusion (the field  $x' y'$  in Figure 2).<sup>138</sup>

Jean Michel Vappereau offered a simplification of the three steps of Lacan's construction of the Optical Schema. The citation of Lacan in the paragraph above can better be understood by the simplified optical schema 2 which we find in Vappereau's comments.<sup>139</sup>

Furthering the Mirror Stage, Lacan's Optical Schema, Figure 2 showed the function of misrecognition by the ego, and more than that it showed 'the twofold impact of the imaginary and the symbolic' on the construction of the subject:

'... once we are forced to conceptualize the subject as the subject in which it( $\zeta a$ ) can speak, without him knowing anything about it (and even about whom we must say that he knows nothing about it insofar as it speaks).'<sup>140</sup>

The relations between the real image  $i(a)$  the libidinal body in the real space, which cannot be seen and  $i'(a)$ , the little other, the virtual image in the virtual, imaginary space, are not symmetrical and they do not lead to a synthesis between the subject and its object-relations. The virtual image (the ideal ego) leads to an image of mastery of the ego, while the subject has little access to  $i(a)$ , the real image of the body, and to its fragmentation by the part object.

---

<sup>138</sup> Ibid: the subject is transferred on the other side of the mirror above the virtual image, as I, ego ideal, which is in the symbolic space, while what is seen in the mirror is the ideal ego,  $i'(a)$ , this is seen in the virtual space. For this second illusion to happen the Other (plane mirror) of speech and language has to be there.

<sup>139</sup> Vappereau, J.-M., *Etoffe*, 1988: 43. Cross-refer this thesis, Chapter 4, pp. 251- 254

<sup>140</sup> Lacan, J., *Ecrits* (2006), op. cit., 566.

‘For in  $i'(a)$ , there is not simply what the subject of the model expects to find, but already a form of the other (with small  $a$ ), whose power, no less that the play of bearing relations that begin there, inserts it as a principle of false mastery and fundamental alienation.’<sup>141</sup>

In order to show the alienation, the subordination of  $i(a)$  to  $i'(a)$  described in Optical Schema Figure 2, Lacan goes back to the real image,  $i(a)$ , of Optical Schema Figure 1: if it involves a ‘subjectification’, he says, it takes place ‘through the pathways of autoconduction’, in the automatic reflection of the body image in the spherical mirror which perhaps represents the brain, some cortical function. The hidden vase indicates the subject’s poor access to the reality of his own body.

Vappereau’s (A) <sup>142</sup> simplification of optical schema Figure 1.

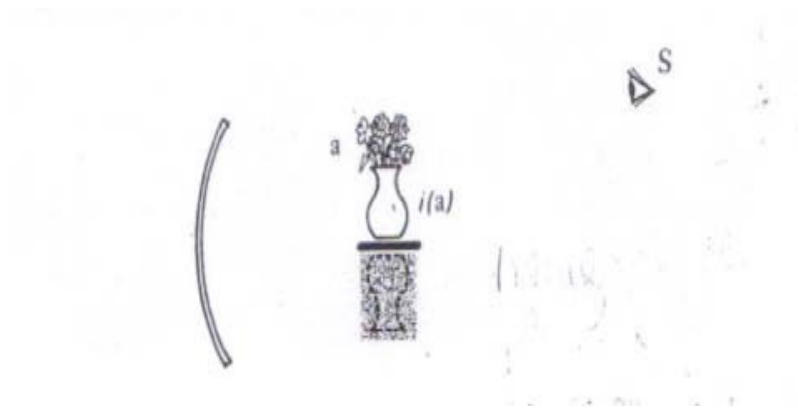

As Lacan puts it, the subject imagines his body like a glove that can be turned inside out, while ‘it is rather ‘a fold of layers that coalesce with his envelope, stitching themselves around the orifice rings’.<sup>143</sup> So, man tries to experience the reality of his body with the so-

<sup>141</sup> Ibid.

<sup>142</sup> Vappereau, J.-M., (1988), op. cit., 43.

<sup>143</sup> Lacan, J., op. cit., 566. This description makes us think of the topological surface which Lacan presented as the cross-cap in his Seminar ‘*Identification*’ (1961-62).

called body techniques while he has lost its reality inside. Psychoanalysis, on the other hand, shows us the libidinal body as an empty shell with its orifices. In those orifices we find psychoanalysis' 'most accurate' discovery, the part-objects, as imaginary plugs. But, object relations theory has reduced this discovery to the ideal of 'totalization of the part-object'; in other words, it has given consistency to the optical illusion of a complete adequacy between the container and the contained. For Lacan, on the contrary, it is not self-evident, that the fragmentation of functional relations in the mirror stage, will lead eventually to a synthesis and harmony between the ego and its objects.

Being situated for the subject in the imaginary 'the antinomy of the images  $i(a)$  and  $i'(a)$  will resolve into 'a constant transitivity', a sort of ego-ideal-ego. It is only the symbolic dimension that can stop this imaginary pendulum. Psychoanalysis, which operates in the symbolic, is able to reshape an ego which is thus reinstated in its imaginary function. On the other hand, Lacan situates the subject in the phenomenon of vanishing - to which Lagache referred concerning the subject-ego- but prefers to call this phenomenon *fading*, 'fading of the subject' in the place of the 'elision of a signifier (\$).' <sup>144</sup> It is in the place of the fading subject that the ego ideal comes. This is a symbolic place. This is why Freud developed his second topography, 'to show the ego's unconscious coordinates'. <sup>145</sup>

Optical Schema Figure 2 includes the moment when the child turns towards the person who is carrying him, asking with a look for his approval and verification of what he sees in the

---

<sup>144</sup> Ibid., 567. But the external object's function as an insignia (a trait, a 'unary trait' as we will see later in Chapter 6), makes that any 'moronic power', as Lacan underlined), can take the place of the ego ideal and its trait constitute the common denominator for identification, as Freud showed in 'Group Psychology and the Analysis of the Ego' (1921c) with the example of Hitler and his moustache.

<sup>145</sup> Ibid. Such an unconscious coordinate of the ego is the unary trait which Lacan develops in Seminar 'Identification' (1961-1962).



mirror, this is what Lacan developed as the function of the Other, who is the locus of discourse, the third party in the process of subjectification.

‘The latter decants the child’s recognition of the image, by verifying it, from the jubilant assumption in which *it* [elle] certainly *already was*...All that subsists here is the being whose advent can only be grasped by no longer being.’<sup>146</sup>

In that image, the subject was there ((‘*il était là*’, with all the ambiguity of the French imperfect tense), just a moment ago, but he no longer is.

Now the earliest subject is in the place of the elision, the void, the Thing that is closest to him, but how can he recognize it? He will rather prefer to find there the marks of a response, insignias, traits. ‘It is the constellation of these insignias that constitutes the subject’s ego -ideal.’<sup>147</sup>

Vappereau’s (A<sup>''</sup>) simplification of optical schema, Figure 2

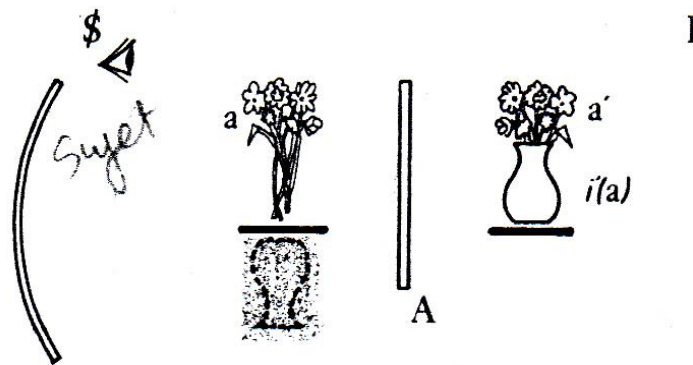

<sup>146</sup> Ibid., 568.

<sup>147</sup> Ibid., 569.

Lacan's Optical Schema Figure 3 (below, p. 257) is a step further showing the incidence of analysis in the process of subjectification, the analyst coming in position *A*. As the subject in the course of analysis is invited to 'assume his unconscious discourse as his own', the trajectory leads 'to a translation of  $\$$  to the signifiers of the space behind the mirror', that is from the position of the ideal ego the barred subject is hypostasised in the ego ideal, *I*. The 'mirror relations drag the subject into the field where he hypostasizes himself as ego ideal.'<sup>148</sup> This Lacan signals, is not the end of analysis which Balint described, the narcissistic effusion, the narcissistic elation where the patient has exchanged his ego for the ego of the analyst. Things do not stop there and this is not the end of analysis, we hope.

How is it different from Optical Schema Figure 2? In Figure 2, the subject had access to the optical illusion of Figure 1, but as a virtual image. The real space was superimposed on the virtual space engendered by mirror *A*. Translated in *S* by mirror *A*, the subject had access to the illusion of the vase and the flowers  $i'(a)$ , to the narcissistic mirage. In Figure 3, on the other hand, the analyst, in position *A*, gradually effaces himself by a rotation first of 90°, then of 180°, bringing the subject in the unthinkable place, at the other end of the room, where he was before and from where he can see 'the illusion fade along with the quest that it guides.' It is marked by the well known effects of depersonalization in analysis. The subject, hypostasized in *I*, can see first in the 90° rotation and for a moment 'the existential divorce in which the body vanishes in spatiality', he can see the flowers but not the vase, and then in the 180° rotation, when the mirror becomes horizontal, he can see again the real image of the flowers and the vase, the image  $i(a)$  produced by the spherical

---

<sup>148</sup> Ibid.

mirror but inverted and reflected as  $i'(a)$ , on the plane flat mirror, 'inverting the real image anew, as it were, and opposing it, like its reflection in water gives dream roots to a tree.'<sup>149</sup>

Optical schema Figure 3 did not clarify the status of 'object  $a$ ' as the 'object cause of desire.' The register of the real was still not formalized. Optical schema Figure 3, produced at an earlier time of his teaching (1958) was first concerned to 'clear away the imaginary which was overvalued in analytic technique.' It gave prominence to the symbolic (read: the subject's subordination). Object  $a$  was taken within the symbolic structure, and had the function of a weapon against desire's disappearance, for example as the phobic object or the fetish. It was not merely a part or even 'a spare part' (*pièce détachée*) of the body, but 'an element of the structure from the outset . . .'<sup>150</sup>

This is precisely what Conté remarked: 'Our [optical] schema leaves us with all the work to be done concerning *the status of the object* which evidently proves to be something of a totally different nature than  $i(a)$ . The schema is based on the provisional fiction, as in Optical Schema Figure 1, of a non-barred subject which could have direct access to the object of desire and then in Figure 2, we see him included with his own image in the Other.'<sup>151</sup> But, this is not the case commonly. The image in the plane mirror,  $i'(a)$ , is marked with a blank, a lack, and this is why the Other is perceived as desiring. The object – it is a trait of the structure – steals itself away from the imaginary function, it has no image in the mirror. This seems to contradict what was said before, but as Conté underlined, the

<sup>149</sup> Ibid., 570. As Vappereau put it: this eclipse cannot last . . . the subject seeing himself as a Narcissus, in a glimpse' (Vappereau, J.-M., op. cit., 44).

<sup>150</sup> Ibid., 571. 'Being selected as the index of desire from among the body's appendages, object  $a$  is already the exponent of a function, a function that sublimates it even before it exercises the function'.

<sup>151</sup> Conté, C., 'The Splitting of the Subject and its Identification', *Scilicet* No 2-3, Paris 1970, reprinted in '*Le réel et le sexuel*', Point Hors Ligne, Paris, 1992, 201.

Optical Schema itself is supported by the gaze, which needs to be subtracted in order for the elements of the structure to take their place: 'Because it is optical, the schema cannot indicate precisely that the gaze as part-object *a* is deeply hidden, not graspable insofar as I cannot see myself from the place the Other looks at me'.<sup>152</sup>

When Lacan, later in his teaching, in Seminar Book X, *Anxiety* (1962-1963) took up his optical schema again he did it not only in order to underline the specular image's dependence on the symbolic order, that is, the subject's dependence 'on the fact that he is constituted in the place of the Other and that his mark is constituted by his relation to the signifier.' He wanted now to articulate anxiety to the structure. It was the moment in which 'Inhibitions, Symptoms, and Anxiety' defined for him another Freudian topography.<sup>153</sup> But this had already started in Seminar Book IX, *Identification* (1961-1962), when the real as object *a* was introduced.

As we argue later in this thesis, the year before the Seminar on *Anxiety* (1962-1963), and in the middle of his Seminar on *Identification* (Book IX, 1961-1962), Lacan opened a new area of investigation heralded by his speech in the *Journées Provinciales* (March 1962) of the French Society of Psychoanalysis (SFP) on Anxiety. In Seminar on *Identification* after developing the theme of the subject's identification to the signifier he presented the idea that anxiety was anxiety of the Other's desire (April 1962). Pierra Aulagnier followed with a presentation on 'anxiety and identification' inspired by Lacan's idea, on May the 2<sup>nd</sup>

---

<sup>152</sup> Ibid. Vappereau called optical schema 3, 'a presentation of the structure of castration'.

<sup>153</sup> Lacan, J., Seminar Book X, *Anxiety* (1962-1963), 28 November 1962, Paris, Seuil (2004).

1962, and from then on Lacan used topology for the development of the real as the space where he would formally place object *a*.

As he underlined in his Seminar on *Anxiety*, the world is structured, as Claude Levi–Strauss demonstrated, there is a cosmos, a structure with almost mathematical rigor (the combinatory); it makes justice to the analytic reason, our reason. But there is also Freud's Other Scene of Dreams, on which 'things come to be said'. It constitutes the psychoanalytic reason, the unconscious with its dimension of time and history. But then, there is a third moment, a scene within a scene (the example is from the tragedy of Hamlet and was noted by Otto Rank). Hamlet staged a scene in which actors play out the murder of his father with the hope that this scene will give him the impetus he lacks to act. But, when the moment comes for him to act, he is in a state of manic agitation, and flounders. The specular identification did not work. But, there was another, more enigmatic identification revealed later, with Ophelia, his object of love, whose suicide after the murder of her father becomes what triggers the act of Hamlet. It was the identification to the object of desire (Ophelia) in the time of mourning, as Freud described in 'Mourning and Melancholia' (1917e). It works and triggers a series of mortal fights for Hamlet who finally kills the king but not before he has been wounded mortally.

Lacan will insist on two things: a) that the object of desire is introduced at a third moment, not that of the world, not that of history, but at the moment of anxiety; b) that in the logic of libidinal investment not all libido was invested on the specular image. There was a remainder, and in that place came the phallus but in its function of lack ( $-\phi$ ). Thus the

optical schema in the complete Figure 3 showed exactly that. In the vacillation of the vertical plane mirror, the libidinal image  $i(a)$ , will not include the flowers.

Optical Schema Figure 3

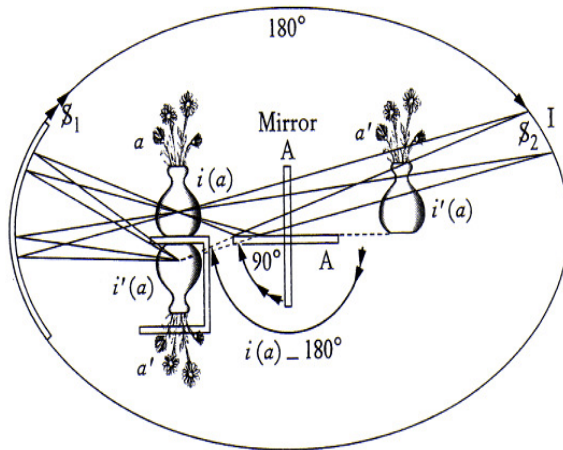

Lacan, J. (1966) *Ecrits*, 570, and, Seminar Book X, *Anxiety*, 1962-1963, p. 50.

And its simplified version <sup>154</sup>

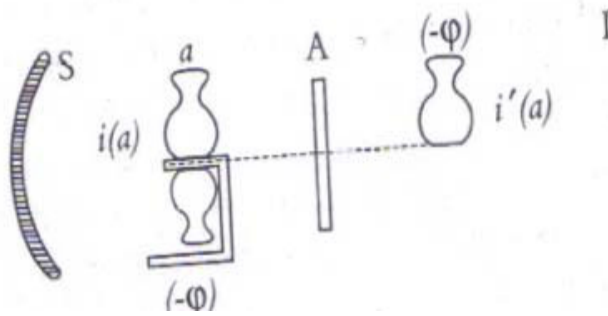

In this figure, object  $a$  appears as lack  $(-\phi)$ .

<sup>154</sup> Ibid.,

This is also what Vappereau showed in his (A''), simplified third optical schema

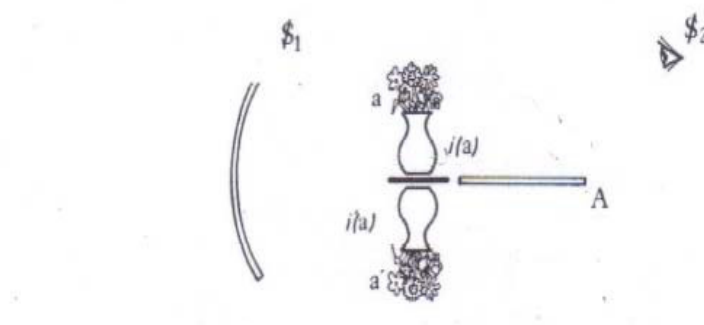

‘Mirror A pivoted a quarter of a complete round. The gaze changed place and came back at the other end of the room, in its first unthinkable position. Therefore it can see the real image of the vase  $i(a)$ , transmitted by the spherical mirror being reflected as on a lake. It duplicates itself and can also be seen below as symmetrical virtual image  $i'(a)$ , where the vase is in the Real. This eclipse cannot last . . . it offers a presentation of the structure of castration.’<sup>155</sup>

In his first published essay ‘On anxiety’ (1964) Conté put his gloss on anxiety and the role of object  $a$ . Object  $a$  resisted any symbolisation; as well as being without a specular image it had a fundamental relation with anxiety. First of all it functioned as a remainder of the subject, as something that had to be conceded, to fall off, for example the part object, breast, faeces, penis. Anxiety, as Conté underlined there, emerged at the moment of disjunction between *jouissance* and its instrument, the phallus exemplified in the moment

<sup>155</sup> Vappereau, J. M., op. cit., 44. Here object  $a$  appears

of its detumescence. Although anxiety was ‘topologically’ within the ego, it did not concern the ego, but the subject as ‘cause of desire’ of the Other.<sup>156</sup>

We turn now to Lacan’s Seminar Book IX to examine the themes of identification, anxiety and division of the subject.

---

<sup>156</sup> Conté, C., ‘*Sur l’angoisse*’ (1964), in ‘Documents, Research and Works’, internal publication of the EFP. Re-printed in ‘The real and the sexual’, (1992), Paris.



## CHAPTER 5

### IDENTIFICATION IN LACAN

#### A. Introduction

Moving from the theme of *Transference* (Seminar Book VIII, 1960-1961) to that of *Identification* (Seminar Book IX, 1961-1962) was inscribed in the logic of ‘pulsation between subject and signifier’, which Lacan had chosen for the development of his Seminar.<sup>1</sup> But there was also another thread. In the final session of his Seminar on *Transference* (21 June 1961),<sup>2</sup> Lacan had questioned the widely accepted notion of the end of analysis as leading to an identification to the analyst, taken as an ego ideal, with the added sliding towards taking him as an ideal ego. Lacan asked if the ‘true’ position of the analyst in the treatment was that of an ego ideal. Those preoccupations had emerged with the formation of a larger analytical group around Freud, and it is very likely, as Lacan suggested, that in *Group Psychology and the Analysis of the Ego* (1921c, *Massenpsychologie und Ichanalyse*) Freud had in mind the problems the analytic ‘mass’ faced when he started examining Le Bon’s work ‘*Psychologie des Foules*’ (1894), a study of the specific groups of the Army and the Church.<sup>3</sup>

---

<sup>1</sup> Lacan, J., *Identification*, 1961-1962, Seminar [Book IX]. This Seminar has not yet been published. Based on a number of sources, typed or handwritten versions of the Seminar, Emile Gabay, psychoanalyst, member of the Association *Errata*, worked on a critical edition of the text which he published as a research document in 1994. This is the version I use.

<sup>2</sup> Lacan, J., *Transference*, Seminar Book VIII (1960-1961), 1991, Paris. The complete title of the Seminar was: ‘*Transference in its subjective disparity, its alleged situation, and its technical excursions.*’ In this Seminar Lacan started with a long comment on Plato’s *Banquet* in which Pausanias, Aristophanes and Diotima debate on love (*eros*) when their developments were subverted by the abrupt entry of Alcibiades. He ended the Seminar with a consideration of the place of the analyst in transference and the necessity to keep the distance between *I* (the ego-ideal) and object *a* (object of desire).

<sup>3</sup> Lacan, J. op. cit., 31 May 1961; Freud, S., (1921c), S. E., **18**, 72.

The confusion that was created between *Ich-ideal*, the ego ideal, and *Idealich*, the ideal ego, was partly due to Freud himself. It played a role in transference. But, Freud had used two distinct terms and his disciples and followers addressed their relation, both structurally and in the clinic, in various ways. H. Nunberg was one of them.<sup>4</sup> M. Balint, an object-relations analyst, had the more striking views. He developed a theory of *primary object-relation* and described the analyst as coming in the place of the object of primitive and passive love. This interests us, namely as the analyst is put in the place of an object, - he even says ‘of the Thing’-, but that was only a reactivation of that ‘primary’ object –relation of which he recommended the use in transference. He saw in that the opportunity of a ‘New Beginning’ for the patient and for the end of the cure.<sup>5</sup>

In his paper ‘Psychoanalysis and Personality Structure’ (1961)<sup>6</sup> Lagache conceived the psychological structure on a *personalistic* mode, and professed the unity of the whole personality, and the autonomy of the ego, as aims of the treatment. As Lacan remarked, he put ‘being’ behind the ‘persona’, which is but a mask (first the word ‘person’ derived from *persona* and meant the role an actor is playing) and with it he replaced the structure. This mask was split and there was probably no one behind.

---

<sup>4</sup> See Nunberg, H., (1932b [1931]), *Allgemeine Neurosenlehre*, transl. as *Principles of Psychoanalysis* (1955). and Jekels, L. and Bergler, E. ‘Transference and Love’ (*Übertragung und Liebe*), a presentation to the Vienna Psychoanalytic Society in 1933, published in *Imago*, 1934. Lacan noted that it contained an interesting clinical insight on the relation between love and guilt, therefore on the role of the superego in transference, and not only of the ego ideal (Lacan, J., Seminar Book VIII, *Transference*, 31 May 1961).

<sup>5</sup> Balint, M., *Primary Love and Psychoanalytic Technique* (1952), Hogarth Press, Maresfield Reprints, 1985. We find this theory in his papers ‘*The Final Goal of Psychoanalytic Treatment*’ (1935), ‘*On Love and Hate*’ (1951). Lacan found this use of transference ‘a radical connivance’, and ‘an excuse for the analyst’s narcissism’. It is ‘a dyadic conception’, and is ‘determined by the image of the ideal ego’, he underlined in ‘*Variations on the Standard Treatment*’ (1955), *Ecrits*, (1966), op. cit., 288.

<sup>6</sup> Lagache, D., ‘*Psychanalyse et structure de la personnalité*’, (Royaumont Colloquium organized by the ‘*Société Française de Psychanalyse*,’ 1958. First published in *La Psychanalyse*, no 6 1961 and later in Lagache, D., *Œuvres*, Vol. IV, 1977)

In order to correctly place ego-ideal and ideal ego in the psychological structure, Lacan presented his own 'model', the 'Optical schema', with which he showed that the end of analysis was neither 'the narcissistic effusion' (unification with the object) which Balint had proclaimed with his 'primary love', nor 'the exchange by the patient of his ego with the analyst's ego.'<sup>7</sup>

In his Seminar Book VIII, *Transference* (1960-1961) Lacan advised the analysts to keep the distance between the ego ideal (*I*), and the object of desire (*a*), and to keep in mind that both, *ego-ideal (I)* and *ideal ego i (a)*, had an interest in the demands of narcissism.<sup>8</sup>

In Seminar Book IX, *Identification* (1961-1962) the purpose was to detach identification from the imaginary field, and to place both, identifications to the ego-ideal and to the object of desire within the logical table of the modalities of lack. Lacan presented the structures of identification as parallel to the operations of *Privation, Frustration, Castration*, that he had first presented in his Seminar Book IV, *The Object Relations* (1956-1957), and argued the presence of a third Freudian topography in the modalities of identifications in Freud's *Massenpsychologie* (1921c), referring to Chapters VII, VIII and XI, and Freud's drawing of the structure of *Ich* differentiating ego-ideal and ideal ego.

---

<sup>7</sup> Lacan, J., Royaumont Colloquium, 1958: 'Remarks on D. Lagache's Presentation, 'Psychoanalysis and Personality Structure', *Ecrits* (1966), op. cit., 543-574. Cf. : This thesis, Chapter 4, pp. 247-260 . The optical schema was first presented by Lacan in his Seminar: 'Freud's Papers on Technique' (1953-1954), Seminar Book I, , 31 March 1954: 'The *Ich-ideal*, the ego-ideal is the other as speaking, the other in so far as he has a symbolic relation to me[*moi*], which . . . is both similar to and different from the imaginary libido . . . the *Ichideal* considered as speaking, can come to be placed in the world of objects on the level of the *Idealich*, that is on the level where the narcissistic captation can take place' (Seminar Book I, op. cit., 142). Lacan radically distinguished 'ego ideal' and 'ideal ego' by making the ego ideal a symbolic introjection and the ideal ego an imaginary projection (ideal ego).

<sup>8</sup> In the systems of Freud's Second Topography, Lacan finds the *Ichideal* and the *Uberich* 'an obstacle immobilizing the subject.' (Lacan, J., Seminar Book VIII, *Transference*, Session 31<sup>st</sup> May 1961). This is why he preferred to talk of the analyst's action, and the analysand's acting-outs, which often point at something outside the narcissistic realm in which an analytic relation can get stuck.

Lacan also sees another possible ‘topography’ in Freud’s *Inhibitions, Symptoms and Anxiety* (1926d), and devoted his Seminar Book X *Anxiety* (1962-1963) to the elaboration of it in relation to which he developed object *a*. With Lacan’s insistence that Freud’s second topography is not personalistic, many of the misgivings of that topography can be addressed.<sup>9</sup>

Freud’s chapters VII, VIII, and XI of *Massenpsychologie* (1921c), those called ‘Identification’, ‘Being in Love and Hypnosis’, and ‘A Differentiating Grade in the Ego’ helped Lacan, starting from Seminar *Identification* (1961-1962) Book IX, to argue that the same object was involved in the identification to the ideal, and the identification of desire to desire, that in both cases it was about the same object, of love or ideal, or collective identification. The ‘unary trait’, Hitler’s moustache for example, concealed the same object as object of desire. But the object of desire being different from the common object, moving in another space, Lacan needed to develop first the topology of that space, the Real,

‘It is not enough to say: there is the ideal identification and then there is the identification of desire to desire . . . Freud’s text does not leave things there . . . insofar as, within the major works of his *third topography* (*topique*), he shows us the relation of the object, which cannot be other here than the object of desire, with the constitution of the ideal itself. He shows it on the level of collective identification . . . by which the unary trait is reflected in the uniqueness of the model.’<sup>10</sup>

<sup>9</sup> Lacan, J., (1966[1958], ‘Remarks on Daniel Lagache’s Presentation’, op. cit., 563. Lacan presents his Seminar *Identification*, as his own metapsychological research (Seminar Book IX, un-published, 14 March 1962).

<sup>10</sup> Lacan, J., *Identification*, Seminar Book IX, 20 June 1962, 281. Concerning the ideal identification, although Freud had underlined the difference between identification and love, finally they were confused in the ‘extreme development’ of love in bondage and fascination. The result was a generalized idealization and sublimation of the object of the drive. Freud pointed out that, while in the simple case of identification ‘the ego enriched itself with the properties of the object, it “introjected” the object into itself, a term Ferenczi coined (1909), in the second case, it is impoverished, it has surrendered itself to the object, it has substituted the object for its own most important constituent’ (Freud, S., 1921c, Chapter VIII, S.E. 18, 113). In extreme cases identification and love were not different. But, for Freud, the real difference is that ‘in the case of identification the object has been lost, or given up; it is then set up against the ego, and the ego makes a partial alteration after the model of the lost object’ (ibid., 114). In the case of love, however, the object has

Lacan takes Freud's second identification as the matrix of identifications. Freud's identification to the 'one trait only' (*ein einziger Zug*) is singled out as exactly that, the incidence of object *a* in identification reflected in the uniqueness of the model on the level of collective identification. will be called by Lacan *unary trait*, a term taken from set theory. The first identification is to the Father in the child's prehistory, an 'enigmatic' identification, as he calls it, is left for a later Seminar. The third identification, which we know as hysterical identification, is identification to the desire of the Other. With the evocation of anxiety of the desire of the Other, a theme discussed during the development of Seminar IX, Lacan invites Pierra Aulagnier to present her paper on 'anxiety and identification' (2 May 1962). Object *a*, was already introduced in session 24 January, 1962.<sup>11</sup>

## **B. Knowledge and desire**

Lacan starts this seminar with the evocation of the same narcissistic image with which he ended Seminar VIII, the emergence of Aphrodite out of the waves, the humid cloth of the surrounding foam only concealing the object of desire, phallus erected, present but

---

been retained at the ego's expense. 'Can there be no identification while the object is retained?' Freud asks. But, Lacan notes on the other hand, that the real essence of the matter is 'whether the object has come in the place of the ego or of the ego ideal' (Lacan, J., 20 June 1962).

<sup>11</sup> Lacan first presented the *einzigiger Zug* as 'a sign', not as a signifier, and with a definite reference to the Other in the narcissistic relation. (Lacan, J., Seminar Book VIII, 1960-1961, *Transference*, 7 June 1961, (Paris, 1991, 413-414). Now, it is a signifier. In the distance which separates Seminar VIII from Seminar IX, as Ego-ideal is connected with the object of desire, it becomes its signifier. In the end of *Transference*, Seminar Book VIII, (1960-1961) Lacan already called *einen einziger Zug* 'the true topography (*topique*) of desire'. He also commented on Freud's '*Inhibitions, Symptoms and Anxiety*' (1926d) and linked anxiety to the object of desire (op. cit., 14 June 1961, 430).

concealed in the auto-erotic rock of castration, only to stress that the experience of the signifier is not that of a narcissistic reflection, but of a trait of difference and cut. There can be, however, reflection in language too. For example, the suffix *-em* in the Latin *id-em*, meaning ‘the same’, is found reduplicated in the French ‘*même*’. There is a *metipsum* and even a *metipsissimum* in low Latin, leading to the French ‘*moi-même*’, a reduplication of the ego itself, a tendency which Lacan defines wittingly as ‘*mihilism*’ (the ‘me’ experience). It is an experience not only of reduplication, but also of repetition. We find it equally in the Greek *αυτός* (‘this one’, ‘the same’ and ‘me’), the French *soi* and the English ‘self’.<sup>12</sup>

The theme of identification is approached by Lacan not from the usual angle of identification to another, but from the point of view of the big Other, and of their difference, and therefore of the traps of identity.<sup>13</sup> It is in the signifier that he finds his support, and for that he turns first to Descartes.

The first questioning of the subject in modern philosophy emerged in the 17<sup>th</sup> Century with Descartes: ‘who am I?’ was the outcome of a long process of thought which ended with the conclusion: ‘I think therefore I am’. But, as Lacan immediately remarks, this is an impossible statement.<sup>14</sup> First of all it is not so sure that the: ‘I think’ is itself a thought.<sup>15</sup>

A question is if ‘the subject who thinks and the subject who says he thinks’, is the same?

<sup>12</sup> Lacan, J., (1961-1962), Seminar Book IX, *Identification*, unpublished, 15 November 1961.

<sup>13</sup> Ibid., 11: ‘If A is A, why to separate it from itself, if it is to put it back again? Russell can give a value of equation to A=A in his *Principia Mathematica* (Russell, B. & Whitehead, A. N., 1910-1913), but Wittgenstein opposed the principle’. The title of Seminar ‘From an Other to the other’ (1968-1969), Book XVI, testifies exactly of that progression.

<sup>14</sup> Lacan, J., op. cit., 22 November 1961, 22.

<sup>15</sup> For example, thought is itself an act and we find this in Freud, for whom it is also a mode of masturbatory satisfaction.

The famous ‘liar paradox’<sup>16</sup> from antiquity shows the impasses arising, if we do not take into account the difference between the level of the statement and the level of the enunciation, something which Lacan had already developed in Seminars Book V’, *The Formations of the Unconscious* (1956-1957), and Book VI, *Desire and its Interpretation* (1957-1958). Secondly, Descartes’ *Cogito* misleads us to consider ‘being as inherent to the subject’, which, if it was true, would only be possible, if the subject was engaged in continuous thinking.

We find at this point in the Seminar a series of neologisms and word-plays based on the *Cogito*. The verbs ‘I think... I am...’ are woven variously to show that they are signifiers, *semblances of being*, and incarnations of the subject. Lacan’s idea is that ‘nothing else supports the traditional philosophical idea of a subject, than the existence of the signifier and of its effects’. The subject is dependent on the signifier, ‘it is about the effects of identification, a sort of incarnation of the subject’.<sup>17</sup>

But, ‘I think’ can also have a dimension of will and judgment, and there is also something less assertive, such as an opinion or an imagination: ‘I think that I think’. Descartes’ subject is a ‘wavering subject’, a subject who doubts. Here is the place to bring in ‘the subject supposed to know’. Lacan underlines that psychoanalysis is opposed to the subject of absolute knowledge, as promoted by Hegel. The subject who knows is ‘a most radical prejudice’, against which psychoanalysis argued, and ‘then only began the possibility of the

---

<sup>16</sup> Koyré, A., *Epiménide le menteur*, Paris, Hermann, 1947.

<sup>17</sup> Lacan, J., *Identification*, November 1961:12. In his Seminar ‘*D’un Autre à l’autre*’ (1968-1969), Book XVI, Lacan said: ‘The Other only gives the stuff of the subject, that is his topology’. Topology was the stuff of the subject given to him by the Other.

Unconscious'. In the Cartesian *Cogito* the only subject of knowledge is the subject supposed to know.<sup>18</sup>

The subject 'supposed to know' can operate 'ironically' as *subject of knowledge*, but at a certain level only, at the *synchronic level*, helping us, at certain crucial moments, to be free of the diachronic deployment of the subject of *absolute knowledge*.<sup>19</sup> There is no subject of 'absolute knowledge'.<sup>20</sup> The subject is a supposition, lies under (*subjicere*) the signifying chain to which knowledge is supposed. Lacan insists on that point, it is his 'motion of defiance':

'Knowledge is inter-subjective, which does not mean that it is knowledge of all, but that it is knowledge of the Other, with a capital A (*Autre*). As for the Other, we have said it, he is not a subject . . . The Other is a *locus* on which, since Aristotle, we have been trying to transfer the powers of the subject . . . that the Other knows, that there is absolute knowledge . . . [ but] the Other not being a subject, knows even less than him.'<sup>21</sup>

From the opening sessions of Seminar IX, we have in place some of the letters Lacan already had used in his algorithms: 1. A, the big Other, the locus of *unconscious knowledge*. 2. \$, the subject which is represented by the signifier *one* (formalized in 1964 as  $S_1$ ), for another signifier (formalized in 1964 as  $S_2$ ) and taken within the signifying chain, where it is lost as being.<sup>22</sup> The subject's misrecognition of his dependence on the locus of the Other

---

<sup>18</sup> Ibid. Lacan started his Seminar IX with the notion of the 'subject supposed to know' which he developed in relation to transference (Conté, C., 'The Splitting of the Subject and his Identification' *Scilicet* 2-3, 1970, reprinted in *Le réel et le sexuel*, 1992).

<sup>19</sup> We know *diachrony* and *synchrony* from structural linguistics. Lacan applied them in the deployment of the subject in the signifying chain as *metonymy* and *metaphor*. (Cf.: This thesis, Chapter 5, 282, note 60)

<sup>20</sup> Conté started his 1970 paper (op. cit.) with the following lines: 'The human subject believed for a while that he could pride himself on a privilege which would be his, to be subject of knowledge and locus of the totalization of knowledge.'

<sup>21</sup> Lacan, J., Op. cit., Seminar Book IX, 15 November 1961, pp17- 18: 'The Other is the rubbish dump of the representatives representing that supposition of knowledge, and this is what we call the unconscious insofar as the subject was itself lost in that supposition of knowledge.'

<sup>22</sup> Representation is replaced by representativeness, 'a signifier is that which represents the subject for another



makes him  $\$$ , while his missing as meaning from his place in the structure makes the Other barred ( $A$  barred).<sup>23</sup> Lacan had placed some of these letters already on his *Graph of Desire*. The first level is  $s(A) \rightarrow A$ , the level of the statement, in which the subject receives his message/ meaning from the Other, and is constituted at the end of the diachronical deployment as ego-ideal,  $I(A)$ . The second level,  $S(A \text{ barred}) \rightarrow \$ \langle \rangle D$ , level of enunciation, in which the subject questions the Other about the object of his desire, ‘what do you want from me’? As there is no answer, the question marks the subject as barred (castration, lost being) and the non-answer or not-knowing (the Other is unconscious), marks the Other as barred (jouissance  $\rightarrow$  lost meaning). Both levels are symbolic, the short-circuits placed below them are the imaginary, on the first level the ego and the image of the little other,  $i(a)$ , on the second the subject’s desire ( $d$ ) is constructed as fantasy ( $\$ \langle \rangle a$ ).

Lacan’s Complete Graph of Desire (Cf.: This thesis, Chapter 4, p. 236)

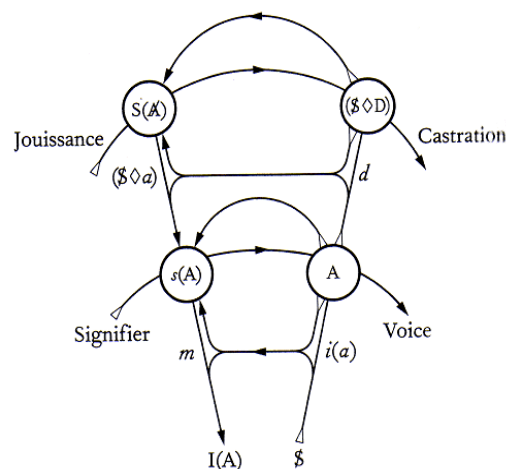

Lacan, J., *Ecrits* (1966), op. cit., 692.

signifier’, this axiom is taken up extensively in this Seminar IX. It had first appeared in ‘Subversion of the Subject and Dialectic of Desire’ *Ecrits* (1966 [1960]), 694. It will be further clarified in *The Four Fundamental Concepts of Psychoanalysis* (1964), Seminar Book XI.

<sup>23</sup> Lacan wrote also the subject as ( $Sa ?$ ), Freud’s *id* (in French *ça*, as in *qu’est-ce que c’est ça?*), with a question mark, insofar as the subject questions the Other and the Other’s desire ( $\$ \langle \rangle a$ ). ‘He [the subject] drags *it* unconsciously, and *it* are the debris which come back to him from what his reality suffers in that thing, unrecognizable debris . . .’ (Lacan, J., *Identification*, 15 November 1961, 18)

In order to talk about identification in a way which brings it closer to our psychoanalytic preoccupations, we need to use Lacan's understanding of the signifier. We need to underline the reversal which Lacan operates in the Saussurian algorithm of the linguistic sign, in order to give the priority to the signifier 'in all realisations of the subject'.<sup>24</sup> He detaches the signifier from the signified and makes it autonomous. He places the subject's identification there: 'for us, analysts, what we mean by identification, what there is in our concrete experience concerning identification, is identification of signifiers.'<sup>25</sup>

Identification is identification of signifiers in a diachrony. It is different from imaginary identification, for which Lacan used the paradigm of the mirror and beyond the mirror, the biological even effects of the image of the fellow other, the assimilation in nature of the image of a fellow animal by another animal. As Saussure showed, there is also synchronic identity. For example 'the Geneva-Paris Express of 8.45pm'<sup>26</sup> is always the same even if the individual trains differ, but this identity presupposes 'a fabulous chain of signifiers organized by the speaking being and entering the real through their intervention.'<sup>27</sup>

Imaginary identity is a bi-univocal relation between two systems, and Saussure with his distinction between signifier and signified opened the door to different interpretations, to

---

<sup>24</sup> Lacan, J., op. cit., 22 November 1962, 19.

<sup>25</sup> Ibid.

<sup>26</sup> Ibid.,

<sup>27</sup> Ibid., 20. Lacan talked instead of the '10h15 Express'; Saussure, F. de, *Cours de Linguistique Générale* (1915), Deuxieme Partie, Chapter III, 151, and for the 'Geneva-Paris Express of 8.45pm', op. cit., 152. In Saussure the linguistic signs, which are also called 'linguistic values', are purely differential, their more exact characteristic is to be what the others are not' (Saussure, F., de, ibid: 167-168; Lacan, J., op. cit., 22 November 1961, 19). By linguistic sign, Saussure defined the 'psychical entity with two faces', the concept (signified) and the acoustic image (signifier). In Saussure's algorithm the concept is above the acoustic image, but the circulation is both ways (Saussure, F. de, op. cit., 158 ff.)

real divergences. There was synchronic identity, for example, between signifiers if the signified was the same.

### **C. From imaginary identification to the unary trait.**

To make things clearer, while imaginary identification excludes difference and finally excludes the Other, identification of signifiers, even in the case of repetition of the same signifier, involves difference, because ‘a signifier never repeats itself the same’. This is ‘the original dimension’ of the symbolic. Also, in the series of signifying elements, a signifier can be singled out because of its dimension, its originality as a trait, a ‘trait of discretion and of cut’. Any signifier can become a signifier-trait, in other words what Lacan called a *unary trait*. It is its singularity that singles it out. Moreover, the system of language with its *diachrony* of the signifying chain and the *synchrony* of the code does not allow the existence of a subject of absolute knowledge. Synchrony does not imply ‘virtual simultaneity in some supposed subject of the code, as that would lead us to the subject of absolute knowledge’.<sup>28</sup> Psychoanalysis leads us, instead, to the subject ‘supposed to know’. Furthermore, it leads us to a subject ‘who does not know’, at least not in the first person: ‘The subject which is ours, this subject which I want to question for us today, regarding the Cartesian method, is the same as the one I introduced in the first trimester of the Seminar *Desire and its Interpretation*.’<sup>29</sup>

---

<sup>28</sup> In Saussure we have a system of linguistic values, 1. Exchangeable; 2, comparative, with no fixed value therefore. All the terms are interdependent from each other, and their value depends on the simultaneous presence of all the others (Saussure, F., de, op. cit., *Deuxième partie*, Chapter IV, 2; Lacan, J., op. cit., 22 November 1961, 21).

<sup>29</sup> Ibid. Lacan, J., (1957-1958), *Desire and its Interpretation*, Seminar Book VI, non-published, session 26 November 1958.

Lacan refers to his comment of the dream with which Freud ended his text ‘Formulations on the Two Principles of Mental Functioning’ (1911b).<sup>30</sup> In Seminar Book VI (1957-1958), in the second stage of the construction of the graph of desire, and following Freud’s interpretation, he placed the dreamer’s sentences, that his ‘father was dead’ and ‘that he did not know it’, on two different levels, the former at the first level, that of the statement, the latter at the top level, the level of the enunciation. ‘According to his wish’, a sentence which Freud supplied as interpretation, was to be placed on the level of the unutterable desire of the dreamer. But, it is in the top level that we find the unconscious, the place of ‘not knowing’, or rather of a knowledge of which the subject knows nothing. ‘The subject is there, but in the third person’, ‘he did not know’.<sup>31</sup> This tallies in with the theory of the elision of *I (je)* when the subject is concerned, which Lacan developed a couple of years later, in *The Four Fundamental Concepts of Psychoanalysis* (1964), Seminar Book XI, the missing signifier which would ‘tell’ who the subject is.

Descartes’ question is if the subject’s being can be found on the ‘I think’. Lacan answers: The ‘I think therefore I am’ leads to an impasse. As psychoanalysts we are used to refer the “I think” to “what about?”, “from where?”, “based on what?” The answer always steals itself away. In thinking, there is an act, while being is in vacillation. We are interested in Descartes’ formula, in case we can find ‘being’ in a pure ‘I think’, but this is impossible, as,

---

<sup>30</sup> It is the dream of the dead father (1911b).

<sup>31</sup> ‘He [his father] did not know that he was dead . . . (according to his -the dreamer’s- wish’). This was how Freud had interpreted the dream by complementing the missing sentence. Lacan comments, ‘In all rigour, and contrary to the opinion of Politzer, it is exactly there that we can designate the subject of the enunciation, but in the third person.’ See Politzer G., *Critique des fondements de la Psychologie*, PUF 1967.

in order to be, a being would have to think continuously. Can we find being in signifiers?

Yes, in a sense, but only as a semblance.<sup>32</sup>

Descartes' subject is vacillating. The act of thinking ends in doubt. '*Perhaps am I, perhaps I?*' There are two ways of interpreting the vacillation of the subject in classical philosophy, first that of Franz Brentano who attributed it to St Thomas Aquinas. Being can only be grasped by thinking at intervals, and therefore without certainty.<sup>33</sup> Lacan proposed an alternative formulation for Descartes' *subject*, wavering between being and thinking: first as a *non-being* or even *a desire not to be*, 'I think and I am not'. '*Je pense and je ne suis.*' Being is spent in thinking and only 'by ceasing to think, I can glimpse that I simply am.'<sup>34</sup>

But there is also a 'not-knowing' involved here, even a desire not to know: A not-knowing on the level of the subject like the one we find in negation, '*Je ne sais, j'sais pas.*'<sup>35</sup> Later in the Seminar, Negation will be the stepping stone towards the three modalities of the

---

<sup>32</sup> Lacan, J., *Identification*, 22 November 1961. Lacan pummels the two verbs 'to think' (*penser*) and 'to be' (*être*) in a series of neologisms, to show that they are signifiers in a series, serial and serious. He creates the verbs '*êtrepenser*', '*j'êtrepense*' and jokes with '*je décompense*' (I have a break-down), or '*pensêtrer, je pensêtre*', and makes a pun with '*s'empêtrer*' (to get entangled). These neologisms, *pensêtrer* and *êtrepenser*, indicate an act which does not involve a subject other than a wavering *I*. The smuggling of *I* in the end of *I think*, is problematic, he says. 'Is it enough that he thinks he is, for him to reach the thinking being?' Lacan composes substantives, too, with the infinitives 'to think' and 'to be', 'the thinkingbeing' (*le pensêtre*), 'the beenthinking' (*l'êtrepenser*) (op. cit., 23).

<sup>33</sup> Ibid. Brentano, F., '*Psychologie du point de vue empirique*', Aubier, Montaigne, 1944. For St Thomas the intellect can only contain one thought at a time; Descartes (1642), '*Meditatio II*', '*Cogitare? Hic invenio: cogitatio est. . . Ego sum, ego existo; certum est.*' Descartes continues by saying clearly that he only exists as long as he thinks. This is the only certainty of his existence.

<sup>34</sup> Lacan, J., *Identification* (1961-1962), 22 November 1961. 'The true meaning of Descartes' initial approach is to articulate *Je pense et je ne suis*, that is, I have spent everything I have as being in thinking' (op. cit., 23-24). In Seminar '*The Logic of Phantasy*' (1967-1968), Book XIV, Lacan phrased it: 'Either I am not or I do not think.'

<sup>35</sup> Lacan, *Identification*, 22 November 1961, 26. On the other hand, the French '*je*' has particularities that *I* or *Ich* have not. You cannot answer the question '*Qui est-ce qui a fait ça?*' (who did that?) by '*je*'. The subject has a particular affinity with negation as shown in the use of the particle of negation *ne* with *Je* as in: '*j'sais pas*', 'don't know',. It affects the grammatical subject, as it has been demonstrated (see: E Pichon and J. Damourette, '*Des mots à la pensée. Essai de grammaire de langue française*', 1911-1940, CNRS), but it affects the subject of psychoanalysis too (Lacan, J., *Identification*, 22 November 1961, 24).

subject's lack, *Privation, Frustration, Castration*, with regards to the object's loss. At the end, it is perhaps a better idea to think of the *Cogito* as an *act*, and even an *acting out*, or a *passage to the act*.<sup>36</sup> Doubt and wavering can be resolved in the act. We find that proposition applied in the treatment.

#### D. From the wavering subject to the unary trait

Descartes' questioning of truth was also important to Lacan's argument about the unary trait. This takes us again to Descartes *Second Meditation's* (1642) passages in which God, although able to deceive us, and perhaps because of that, is the only guarantor of truth: 'This truth towards which Descartes advances with his conquering step, is the truth of the Thing.'<sup>37</sup> God as guarantor of the truth, a proof of the real, we can say. It contrasts with other anterior proofs of the existence of God, because it is an appeal not to God's being (*entissimum*), but to truth itself (*verissimum*). 'God who could deceive us, could turn truth to error, if he wanted to . . . must, for that very reason, ultimately, ensure that truth exists'. He is the only guarantee that truth exists.<sup>38</sup> Therefore, the wavering subject finds its certainty in the unique (unary) trait of the structure (a trait of 'the Thing'):

---

<sup>36</sup> Cf. this thesis, this chapter, note 33 (**Descartes Second Meditation**). Lacan, op. cit.: 'The first moment of the Cartesian Meditation has the trait of a passage to the act'. Lacan differentiates between 'passage to the act' and 'acting out', but they both have a relation to the Other. If the relation to the Other is like a scene where the subject comes to be constituted, the passage to the act is a falling out (*laisser tomber*) from that scene, a precipitate exit, and shows object *a*. In *acting out*, on the contrary, the subject is still on the scene, but outside a relation of speech with the analyst as the Other. He is in 'wild transference', but he is still addressing the analyst as the Other; Lacan, J., Seminar *Anxiety* (1962-1963), Book X, 23 January 1963).

<sup>37</sup> Lacan, J., *Identification*, 17 January 1962: 83. 'Descartes reduces the body to a pure expanse, makes it vanish', it is the imaginary separated from the play of signifiers. What this leads us to is: 'to empty the world and leave only that emptiness – which Descartes called "expanse" (*étendue*)'. On that emptiness of the imaginary of the body, the signifier can be inscribed, is Lacan's argument.

<sup>38</sup> Lacan, J., op. cit., 22 November 1961: 26.

‘What we find at the limits of the Cartesian experience as such of the wavering subject, is the necessity of that guarantor, the simplest trait of structure, the unique trait . . . absolutely depersonalised, not only of any subjective content, but even of any variation which goes beyond that unique trait, that trait which is [one, for being] the single trait’.<sup>39</sup>

Lacan is aware that there can be a suspicion of idealism concerning the *unary trait*, due to the function of idealisation that the trait has. It was after all standing for the ego-ideal. This is why Lacan insists on its structural necessity, a necessity he compares to the invention of the ego ideal by Freud. From that point, ‘which is not mythical, but concrete’, the experience of identification starts, identification of the subject to the ‘radical signifier,’ to the single trait as such. From there, the perspective of the subject as not knowing can be rigorously deployed’.<sup>40</sup> With the ‘unary trait’ Lacan introduces the signifier as ‘one’, which ‘must, in some way, be the subject.’<sup>41</sup>

But the one he is leading us to ‘is neither . . . the One of Parmenides<sup>42</sup> nor . . . the One of Plotinus’.<sup>43</sup> It is not the one of any totality, but the ‘one trait only’ of Freud’s second

---

<sup>39</sup> Ibid. Lacan introduces soon a term borrowed from set theory: ‘unary trait’ (*trait unaire*). We find it in his intervention in English: ‘On Structure as the Immixing of an Otherness to any Subject Whatever’, at the *International Symposium on Structure*, Baltimore (1966). Lacan talked there of the ‘unitary trait’, a trait of sameness first appearing as ‘mark’, then being ‘rubbed out’, removing the difference involved in the ‘thing’ which is lost. The ‘unitary trait’ is the ‘number so and so’ of the experience which is lost, he argued. His development of it was largely based on Frege’s theory of the genesis of numbers (Frege, G., *Grundlagen der Arithmetik*, 1884). During the above mentioned Symposium he also argued that the question of the subject resides in number 2: ‘2 is the first number to appear in the place of 1 which has been effaced and therefore 1 is in the place of 0.’  $n+1$  is the basis of Frege’s theory of the genesis of numbers. Lacan considers the  $1+1$  of repetition as the unit. Thus, ‘the trait insures the difference of identity’ and the subject is divided (*fading*).

<sup>40</sup> Lacan, J., op. cit., 29 November 1961: 27.

<sup>41</sup> Ibid. A year later, in his Seminar *Anxiety* (1962-1963), Book X, session 21 November 1962, Lacan reiterated, ‘There is no conceivable appearance of a subject as such than starting with the first introduction of a signifier and of the simplest signifier . . . the unary trait. The unary trait is before the subject. In the beginning there was the word, means in the beginning there was the unary trait...’ Lacan also called it ‘*initium subjectif*’. It is the first signifier to enter the real. It makes the subject emerge in the real (Lacan, J, op. cit., 29 November 1961: 31).

<sup>42</sup> Ibid. Parmenides, the pre-socratic philosopher, is known for his *Poem* in which he presented his philosophy of being; Parmenides, *Poem*, Fragm. 3: *το γαρ αυτο εστιν νοειν τε και ειναι*, ‘therefore being and thinking are

identification. The unary trait is the single stroke, /, the baton, the notation of number 1, as the schoolmaster writes it down.<sup>44</sup>

### E. The unary trait and identification.

If we have to think of identification as not a unity but the relation between ‘one’ and something else, then we have to question what else is at stake in identification outside the single stroke, /, 1. Is it the being of the thinking being?

‘If what thinks, our recently talked about ‘thinkingbeing’ (*l’êtrepensant*) remains in its opacity at the level of the real, it is not self-evident that ‘somebeing’ (*quelqu’être*) emerges from it with which we can identify it, not ‘evensomebeing’ (*quelqu’être-même*) which thrown on the pavement as some wide expanse (*étendue*), had to be cleared first and made empty by thought’.<sup>45</sup>

---

the same’. In Plato’s ‘Parmenides,’ Socrates asks the philosopher : *Σὺ μὲν γὰρ ἐν τοῖς ποιήμασιν ἐν φησὶ εἶναι τὸ πᾶν* (‘In your poems, Parmenides, you say ‘one’ is everything [one is all].’ (Plato, ‘Parmenides’, 128b).

<sup>43</sup> Lacan, J., *Ibid.* In Plotinus ‘One is the disappearance of a distinction between subject and object, intellect and light, a sudden appearance of inner light’. There exists a mystical vision of the One, *a Theophany*, ‘a direct inner awareness of the One’. In Plotinus’ *Enneads*, V, [32], we find a table concerning the mystical vision of the One. As John Bussanich commented, ‘the intellect moves away from its normal intellectual apprehension of the intelligible beings towards the direct inner awareness of the One.’ (*The One and its Relation to the Intellect in Plotinus*, by John Bussanich, Brill, 1988). Following the Platonic tradition of the idea, Plotinus writes in the *Enneads*: *ἐν εἶναι τὸν ἐν παρουσία - one is the presence of the one.* (Philosophia Antiqua, Vol. XLIX).

<sup>44</sup> Lacan, J., *op. cit.*, 29 November 1961, [27]. The Greek term for the cardinal numeral ‘one’: εἷς, μίᾱ, ἐν, orig. ἐνς < ἐμς, indo-europ. sem-; ὁμοσ. *To ἐν: the one*, either ‘unity’, as in Mathematics or ‘the One’ as in Philosophy. (See Liddell-Scott, *Ancient Greek Dictionary*, Clarendon Press, Oxford, 1985). There was a debate in ancient philosophy concerning the nature and relation of ‘one’ (ἐν) to ‘all, everything’ (πᾶν) or to ‘many’ (πλείω), therefore about the unity or multiplicity of one; Heraclitus, Fr.10: *Ἐκ πάντων ἐν καὶ ἐξ ἑνὸς πάντα*, from all [derives] one and from one [derive] all. For Plato, *one* is *one* because it partakes of the *eidōs* (idea) of the *monad*, two is two because it partakes of the *eidōs* of the *dyad* etc. *To εἶδος* (the idea) is the cause of everything. (Plato, ‘Phaedo’, 100-101c). ‘Isn’t it true that, what we understand as one, as always one and the same in everything, is the idea?’ (*Εἴτα οὐκ εἶδος ἐστὶ τούτο τὸ νοούμενον ἐν εἶναι, αἰεὶ ὅν τὸ αὐτὸ ἐπιπᾶσιν;*) (Plato, *Parmenides* 132c). In his Seminar *Ou pire*, 15 March 1972, Lacan argued that Plato’s *eidōs* (εἶδος) has been inappropriately translated as form (or idea), that it has more to do with the real, and ‘this is why without knowing it Plato was Lacanian’. It was more like the unary trait. For Aristotle, on the other hand, the one admits multiplicity, as with the numbers, ‘number is many ones’ (*ὁ ἀριθμὸς ἐστὶ ἐνα πλείω*, Aristotle *Metaph.*, 1056b).

<sup>45</sup> Lacan, J., *Identification*, 29 November 1961: 27. Following M. Cholet’s version, the English translator proposes, ‘we can glimpse him among so many beings’ (*tant d’êtres*). However, Lacan underlined that he said *tant d’être* in one word. Another example is his later ‘*parlêtre*’. *L’étendue* is one of Descartes’ space coordinates, a wide expanse which is empty, on which the body cannot imprint any natural trace. The world



No, we are not there. But Lacan allows for something else:

‘At the level of the real, what we can [do] is glance at it between *somuch being*... *somuchbeing* (*tantd’être*), of a *beingbeing* (*êtreétant*), suspended on some tit, capable, at the most, to start up that sort of palpitation of being which makes the enchanter laugh from the bottom of the tomb, in which the canning lady of the lake locked him up’.<sup>46</sup>

Now, that he talks about the empty space of the real, Lacan replaces the ‘*somuchbeing of somebeing*’ suspended on some tits and just able to start being’s palpitation, which makes the enchanter laugh,’ with letters *A+a*. It is one case for the subject’s identification, imaginary identification. As for the monster Chapalu, sated after eating the dead sphinx’s bodies, he proclaims: ‘he who eats is never alone’.<sup>47</sup>

There is also another possibility beyond the fantasy of reunion with the object. We have Freud’s grandson’s ‘*fort-da*’ game or the crumpled giraffe in ‘Little Hans’s’ dream. There is symbolic identification. The subject, *I*, relates, perhaps, simply to a letter, letter *a*, standing for the missing object *a*. The real of the object is replaced by a letter. But a trace remains. *I+a*

---

of signifier is separated from the body of passions which is mere imaginary in Descartes. Lacan, J., op. cit., 17 January 1962.

<sup>46</sup> Lacan, J., op. cit. Some five years earlier, in his Seminar *The Psychoses* (1955-1956), Book III, Lacan evoked the monster Chapalu, the ‘father-child in relation to the mother’, sated with the bodies of the sphinxes after their suicide, and saying: ‘He who eats is no longer alone’. (Lacan, J., Op. cit., 4 July 1956). The scene was described in Guillaume Apollinaire’s 1909 poem, ‘The rotting Enchanter’ (*L’enchanteur pourrissant*, Paris, Gallimard, 1972).

<sup>47</sup> Both scenes are from Apollinaire’s poem. ‘Of course, for truth to come to being (*au jour de l’être*) there is the perspective of the enchanter. It is that which regulates everything.’ Perhaps there is another homophony here, between ‘letter’ and ‘being, *lettre / l’être*, letter replacing ‘being’. Lacan associates the emptiness of the tomb with the place from where truth emerges, Α-λήθεια. ‘As psychoanalysts, we are, of course, greatly interested in truth’, he says, ‘but we cannot emulate the enchanter’. Truth from beyond the grave, beyond death, will be likened to the unary trait. It is truth within the real, ‘it is the subject who brings truth within the real with signifier one.’ (Lacan, J., op. cit. 27-28).

This tantalizing and rather obscure paragraph we cited above with its neologisms in abundance refers, we think, not to the mere play of words, to the signifier's infinite deployment. They evoke the theme of the letter (*lettrepensant?*), which Lacan will develop in the following sessions of the Seminar, and of object *a* as letter. The letter has a relation with the matter, the substance of which is emptied in order for the letter to be written, and although it is first found on living matter (be it on the bones of animals, or on the human body) it is only a trace on it. Lacan had said about the symbolic order: 'The word is the murder of the thing'. Here we can say that 'the letter is the trace of the thing.' This goes beyond 'the perspective of the enchanter,' as Lacan says here, who 'puts everything in order' from beyond the grave for truth to come to light'; it brings to light the letter for the advent of being (*pour qu'il vienne au jour de l' être*). While not real, the letter enters the real.

Speech was associated with truth in psychoanalysis, and people ask 'the real truth' (le vrai du vrai) from psychoanalysts, but, 'it is scarce amongst them'. Lacan finds the unary trait in Freud's '*einziger Zug*' (from 'Identification', in *Massenpsychologie*, 1921c), which 'does not bring truth in the real, but the status of the subject . . . who is in charge to bring truth in the real'.<sup>48</sup> For, it is from the perspective of the *einziger Zug*, and not from that of the enchanter, that truth can be guaranteed and accessed.

---

<sup>48</sup> Lacan, J., *Identifiication*, 29 November 1961: 28. Neither the enchanter nor Chapalu, the satiated monster, but letters A and a.

‘The Instance of the Letter in the Unconscious’ Lacan’s 1957 presentation (*Ecrits*, 1966), had made his audience alert about the meaning he gave to the letter, as ‘literally, the material support of language.’ In Saussure’s algorithm he had placed the signifier, over the signified, letter was something of the order of the signifier, heard, but also, written. Now, in *Identification* (1961-1962) Seminar Book IX, what is underlined is the letter as trace on a surface, written trace, effaced trace, sometimes false trace. There was already, of course, the duplicity of the signifier, and of the letter, but the latter has now a relation with the real.<sup>49</sup> While Lacan answered a possible or existing reproach, that ‘identification would be the key to explain everything’, by avoiding the reference to the imaginary relation to the body, which until then had supported its experience’.<sup>50</sup> With his choice of the linguistic reference for the process of identification, Lacan extracted identification from the imaginary process, but did not avoid the relation to the body. He also did not avoid the so-called ‘preverbal’ or ‘babyish’, or ‘animal talk,’ but argued that it was only articulated language –via the signifier- which allowed that someone put the substance of another in somebody, took them for that Other, put them in the place of the Other, ‘as it happens in transference, identification [is] what can precisely, and as intensely as you can imagine, make you . . . put the substance of an Other in any being of your relation’.<sup>51</sup>

---

<sup>49</sup> The unique or unary trait, radical signifier of the inaugural identification of the subject, trait of guarantee of truth which can also lie, that structure is proposed as the Unconscious here by Lacan. It has to do with writing and the real.

<sup>50</sup> Lacan, J., *Identification*, 29 November 1961. This is Emile Gabay’s version, indicating that Lacan was criticized for the linguistic treatment of the theme of identification, *as if* with that he avoided to address the problems of identification which is based on our experience *of* and imaginary relation *to* the body. The other version by Monique Cholet indicates that ‘identification would be the key to explain everything *if it* avoided the reference to the imaginary relation.’ But this is exactly what Lacan does, and does not tally with what follows.

<sup>51</sup> Lacan, J., *ibid*, 33.

A few words are needed here on the most archaic form of identification, ‘incorporation’ (*Einverleibung*) which Freud described in ‘Totem and Taboo’ (1913) and which supported his first kind of identification, that to the Father as ideal. Lacan related that identification to the phenomena of bilocation we find in folklore and legends, which have nothing to do with irrationality, pre-logical mentality, or mystical participation, as Lévy-Brühl had argued.<sup>52</sup> They were closer to the enigmatic first identification. The recognition, ‘this is him,’ which the farmer utters as he believes he saw his dead master return in the form of a field mouse, ‘this is what symbolic identification is about and it is identification to the signifier’, Lacan argued.

#### F. Is ‘A is A’ true?

‘If *A is A* is true, why to separate it from itself if we are about to bring it back again?’<sup>53</sup> The identity of propositions, *A is A*, is thrown into turmoil as the question arises if it caused more confusion in Logic than anything else. For Lacan, it constituted the condition of an era of thought which ended with Descartes, the theological era. Linguistic analysis, on the other hand is correlative to the advent of modern mathematics, especially set theory, in which we saw ‘the extensive use of the signifier.’<sup>54</sup>

---

<sup>52</sup> Ibid. Lévy-Brühl, French sociologist contemporary of Lacan whose theory of ‘primitive thought’ and ‘prelogical thought’ was cited already by Lacan in his 1932 Thesis.

<sup>53</sup> Lacan, J., *Identification*, 15 November 1961: 11. In *Principia Mathematica* (1910-1913), Russell B. and Whitehead A. N. gave a value of equation to the making of equality  $A=A$ . Wittgenstein, L. in his *Tractatus Logico-Philosophicus* (1922), 4, 243, found these propositions meaningless and did not even accept them as propositions.

<sup>54</sup> Lacan, J., *ibid.*, 34.

As Lacan argued, if 'A is A' is put into question, this will make some progress in the question of identification: 'If A=A is wrong, then I can make my demonstration based on the function of the *one*.' Lacan finds what he is looking for in de Saussure's 'Lessons of General Linguistics', namely in Chapter IV, 'The Sign considered in its Totality'.

'Applied to the unit, the principle of differentiation can be formulated as follows: the characters of the unit are confused with the unit itself. In language, as in any semeiological system, what distinguishes a sign is all what constitutes it. It is the difference which makes the character, as well as it makes the value of the unit'.<sup>55</sup>

The identity of the sign resides in its difference with all the other signs.

'In contrast to the sign ... what distinguishes the signifier is solely to be what all the others are not.' In its function, and in its structure as a unit, the signifier is pure difference. But, it is not constituted as a single trait (*trait unique*) by being subtracted from the synchronic axis. It cannot be thought in any other way than: [what Lacan now proposes ]: 'the "one" as such is the Other. *The A of 'A is A' is in the Other*'.<sup>56</sup>

This is Lacan's 'big word.'

'A is A' is 'a belief', a formula which 'caused confusion in logic'.<sup>57</sup> Lacan draws our attention to the copula, *is*, which we find in the phenomena of bi-location cited above but

<sup>55</sup> Saussure, F. de, 'Cours de Linguistique Générale (1915), Deuxième Partie, Chapitre IV, 4, 'Le signe considéré dans sa totalité', Payot, Paris, 1972, 168.

<sup>56</sup> Lacan, J., op. cit., 29 November 1962: 35.

<sup>57</sup> Since Aristotle, Logic dealt with the question of identity: 'Only to things that are indistinguishable and one in being is it generally agreed that all the same attributes belong.' (Aristotle, *De Soph. Elench.* 24 (179a 37). In Plato's *Parmenides*, Socrates debates with both Parmenides and the chief of the Eleatic School, Zeno, about the nature of the 'one' and about identity. Parmenides proves that the *one* is *one* by using the argument

also in the *Fort-Da* play, in an implicit way. This copula is placed in the gap between the two appearances of the object, he said, and, indicates the place of the subject, the presence of the subject. Although this is somehow obscure, it lead Lacan to the question of the mark or trace of the subject, the '*pas*' (step) of Friday in Robinson Crusoe's island, '*pas*' which in French can also be heard as 'not'. From the moment it is erased it is not a step, anymore, which means it can be read as the '*pas*' of negation. So, '*a* is *a*' has that stigma, that mark, that false consistency which establishes identity, but it is not a true proposition. It denies what it affirms, as the trace of steps can be effaced, or a false trace created. All those are marks of the presence of the subject. Finally what is important to understand is that logic uses letters, that the letter is the support of the signifier.<sup>58</sup>

All the above modalities of identification including that of the letter -and there are some singularities with the letter- are in the symbolic order. On the other hand, imaginary identification is the experience of Lacan's dog.

We need to stress here that: 1. *the signifier is not the sign*, 2: *the signifier is the 'unary' but not the unique trait*. As a unary trait, it designates multiplicity, as in the notches of the Magdalenian bones. But first there is the sign.

---

of identity, and Zeno's dialectic methods of opposite and contradictory propositions. Socrates uses the theory of '*eidōs*', the one is one because of its participation in the '*eidōs*' of the monad.

<sup>58</sup> Lacan, J., op. cit., 6 December 1961: 37-39. But even if the second apparition was a different perception, identity would have been established, if such was the desire of the subject. In the 'Project' (1950a [1895]), Freud introduced a process which he called judging. It aims at identity of perception. It is basically a primary process. The aim is to go back to the missing neurone b -the wishful cathexis- and to release the sensation of identity.' Freud notes that between the perceptual cathexis (neurone *c*) and the wishful cathexis (missing neurone *b*), there can be 'dissimilarity', or even complete non- coincidence. Still the aim is the same, and language will establish identity of perception, as Freud notes: 'language will later apply the term judgment to this dissection [between two different cathexes] and will discover the resemblance' (Freud, S., 1950[1895], S.E. 1, 329).



production of new meaning in repetition, there is no tautology. <sup>62</sup> There is no tautology, because the signifier is different from itself.

The term ideogram is inadequate here and we can see this especially with the Chinese letters. They are ‘*einzig* *Züge*’ in their way. Each one is different, but their differences are reduced, they have the power to signify but they have not any signification separately. They are signifiers and not signs. <sup>63</sup>

*Ein einziger Zug* as signifier *unary trait* (one), is a simple trait in which all qualitative differences are reduced, all little lines look the same, but this does not eliminate signifying difference. One can compare a text in Chinese calligraphy and another in ordinary Chinese

---

<sup>62</sup> Lacan, J., *Identification*, 6 December 1961: 41. When Lacan says ‘my grandfather is my grandfather’ everybody understands that it is not as if he was saying: ‘this is my grand-father’, or as if he had used his grand-father’s name: Emile Lacan. Lacan finds the opportunity here to mention Russell’s theory of the proper name, which he will openly criticize a few sessions later (20 December 1961) . . . As Russell himself said, the theory he develops in this early paper is different from the one he developed in *Principia Mathematica* (Russell B., and Whitehead, A. N., 1910-1913) which ‘*was the same as Frege’s*’. Frege, differentiated *Sinn* (Meaning) from *Bedeutung* (reference or denotation). In *On Denoting* Russell developed the theory that the subject of the denoting proposition (reference) has no meaning in isolation, but a meaning is assigned to it in relation to the proposition in which it occurs. ‘The denoting phrase is denoting only by virtue of its form’. Thus, Russell faced a problem, when he tried to bring in the proper name as a denoting phrase, as equivalent to the demonstrative pronoun, *this*, *that*, or even to *a point in the blackboard*. Of course the proper name does not mean anything, and if Russell’s denoting propositions involved existence, ‘the King of France’ was a false denotation. As Miller, J.-A. pointed out: ‘. . . the proper name requires a special logical treatment . . . he [Russell] broadens the concept of the proper name to include what he calls definite descriptions, . . . expressions occasionally including proper names that supposedly refer to one and only one person... but definition is not guarantee of existence.’ According to Russell’s theory of denotation, the proposition ‘The present King of England’ in 1905 was ‘a false denotation.’ As Miller underlined in his Seminar ‘The nature of semblants’ (27 Nov. 1991), such a theory put in question the nature of the *semblant*, the signifier as semblant. Only when Kripke (1972) returned to the proper name its status as ‘pure signifier’, Lacan was able to support his own theory of the proper name. According to Kripke, ‘definition does not guarantee existence’. Thus, that the ‘present King of England’ does not exist, does not make the denotation *C(x)* false and even if Walter Scott had not written *Waverley*, nothing stops us from conceiving a world in which this is the case, and in which Walter Scott exists as a proper name.’ Miller refers here to Russell’s example of the false attribution of ‘*Waverley*’ to Walter Scott. (Miller, J.-A. ‘The inexistent seminar’, 1995, in *Psychoanalytic Notebooks*, No 15, 43-64, Sept., 2006).

<sup>63</sup> Lacan, J., Seminar *Identification*, 6 December 1961: 42; ‘Contrarily to the sign, the signifier is not what represents something for someone, it is precisely that which represents the subject for another signifier’. Lacan’s definition of the signifier was reiterated at the end of that session. (Op. cit., 47)



which have exactly the same meaning. Thus, qualitative differences do not account for the signifier's radical difference. Lacan found his *signifier one* in the series of notches engraved on the rib bone of a prehistoric mammal, he saw amongst the other exhibits in the 'St Germain-en-Laye Museum of National Antiquities.'<sup>64</sup>

As he explains, the importance of the notch is that *it only can mark the difference in an otherwise non-differentiated real*. Lacan underlines that the difference the signifier is able to introduce in the real is *not a qualitative difference, it is a certain numbering* of the real. This is why the signifier is not the sign, and its identity 'is not an identity of resemblance.'<sup>65</sup>

The modalities of the appearance of the subject:

1. The subject *as a function of metonymy* appears with *very little meaning*:

$$f(S' S'' S''') \dots \sim S(-)s.$$

$$=$$

Lacan, J., (1966) 'The agency of the Letter', *Ecrits*, 2006, 428

---

<sup>64</sup> Ibid., 44. The bushman felt the need to mark each successful hunting expedition: so many successful hunts, so many notches. In the sameness of the experience, their difference would have been lost, if it wasn't for their numbering. A reference to Marquis de Sade's sexual exploits completes the account which here has to do with the repetition of *jouissance*. The famous marquis de Sade, while engaged in some orgy with multiple partners, felt the need to mark the number of times of these exploits on the wall by the bed. The case was referred to the Courts. An account of the case is to be found in G. Lely's *Vie du Marquis de Sade*, Paris 1952. In Seminar Book V, *The Formations of the Unconscious*, 26 March 1958, Lacan referred to the castration complex as the relation between a desire and a mark.

<sup>65</sup> Ibid., 45. This is a statement concerning the radical alterity (otherness) of the signifier.

2. The subject as a *function of metaphor* appears as *new meaning*.

$$f \frac{(S')}{(S)} S \sim S(+s) =$$

(‘The agency of the Letter’, *Ecrits*, 1966, op.cit., 2006, 429)

3. Repetition (S’ S” S”” ...)

Finally, in the automatism of repetition, what is at stake is not that the same things are always repeated, but ‘why’ they are repeated. Here it is the number of a certain experience that is lost and namely the most symptomatic one.<sup>66</sup>

### G. The ‘unary trait’ and the ‘one’ of Mathematicians.

According to Lacan, the ‘one’ that interests us in the subject’s identification is closer to the ‘one’ of mathematicians than to the ‘one’ of philosophers. Amongst the former, Euclid gave a definition of the ‘*monad*’ [‘unit’, or ‘one’] which is quite close to the definition Lacan tries to formulate here:

Μονάς εστι καθ’ην έκαστον τών όντων έν λέγεται  
Αριθμός δε το εκ μονάδων συγκείμενον πλήθος  
(Euclid, *Elements* 4, VII).

‘Unit (*monas*) is that by which each being is said to be one...,’ - but there is an ambiguity

<sup>66</sup> Conté reminds us that according to Freud the unconscious seeks the identity of perception, ‘namely that which was perceived that one time, but is lost and in whose place certain cycles of behavior appear.’ (Conté, C., ‘The splitting of the subject and its identification, in *Le réel et le sexuel*, Point Hors Ligne, Paris 1992, 190).

there, and it would be clearer to say-: ‘It is through the intermediary of the unit that each one of these beings is said to be one.’ Lacan immediately declares that ‘*monas*’ is his unary trait. They both support difference, the difference by which something is distinguished from what surrounds it.<sup>67</sup>

The second line of the Euclidian definition – we give again Lacan’s comment - concerns the relation between ‘one’ and ‘many’, ‘one’ and multitude. Euclid’s answer to that question, which the ancients debated already, was that ‘the number itself is nothing else than that sort of multiplicity which emerges precisely from the introduction of units (*monads*).’ Euclid’s definition of the number, as ‘the multitude made of units,’ will have its counterpart in Frege’s theory of the genesis of numbers.<sup>68</sup>

#### **H. The ‘one’ is involved in identification, but also in repetition**

The one as the ‘unary trait’, ‘the hidden face of the *einzigster Zug*’ involved in Freud’s second identification, was a regressive (regression from love to identification) and highly restricted form of identification.<sup>69</sup> Freud had summed up the three forms of identification as follows:

<sup>67</sup> Lacan, J., *Identification*, 11 December 1961: 49.

<sup>68</sup> Ibid. Frege, G., *Grundlagen der Arithmetik* (1884), in ‘*Les fondements de l’Arithmétique*’ Seuil, Paris (1969), esp. Chapter 3, ‘*Quelques opinions sur l’unité et sur l’un.*’

<sup>69</sup> Lacan, J., op. cit., 13 December 1961. In Seminar Book VIII, *Transference*, 7 June 1961, Lacan presented the *einzigster Zug* as ‘possibly a sign, big *I* and sign of the Other’s approval’. For Freud the second identification occurred when the symptoms were constructed, under repression, and when the mechanisms of the unconscious were dominant. Object-choice turned to identification: ‘. . . the ego sometimes copies the person who is not loved, and sometimes the one who is loved. In both cases the identification is a *partial and extremely limited one* (*höchst beschränkte*) and only borrows a single trait from the person who is its object.’ (Freud, S., 1921c, S.E. 18, 107).

‘First, identification is the original form of an emotional tie with an object; secondly, in a regressive way it becomes a substitute for a libidinal object-tie. . . by means of introjections of the object into the ego (*Ich*); and thirdly it may arise with any perception of a common quality . . . thus represent the beginning of a new tie.’<sup>70</sup>

Lacan’s own choice for the matrix of identification, in Seminar Book IX, was also ‘highly restricted’ to the second form of identification, identification to signifier one.<sup>71</sup> Then, he left out the development of Freud’s first identification, a ‘singularly ambivalent identification’ taking place ‘on the background of an image of devouring assimilation’.

In Seminar Book IX, Lacan articulated Freud’s first, second and third identification with what happens to the subject in the logic of lack of the object, as demonstrated by him in his table *Privation, Frustration, Castration*, already in Seminar *The Object Relations* (1956-1957, Book IV) and further here. The first identification to the father had been introduced by Freud in his ‘Totem and Taboo’ (1912-1913), linked to the ritual killing and mourning of the totem animal and the festival of the totemic meal, and traced as far back as the myth of the killing of the primary father of the horde. Lacan called it an enigma. It was described by Freud in ‘Group Psychology and the Analysis of the Ego’ (1921c) as identification to the father of the child’s own prehistory before any object-choice and as ‘a derivative of the oral phase of the organisation of the libido . . .’<sup>72</sup>

---

<sup>70</sup> Freud, *ibid.*, 107-108.

<sup>71</sup> Lacan, J., *Identification*, 13 December 1961: 50. In Seminar Book XI, *The Four Fundamental Concepts of Psychoanalysis* (Book XI, 17 June 1964) Lacan made clear that the unary trait was not in the narcissistic field, in which Freud had initially placed it ‘The unary trait upon which the subject is suspended in the field of desire . . . could not be constituted other than in the reign of the signifier . . . It is the field of the Other which determines the function of the unary trait, insofar as with it starts a major moment in the *topography* which was then developed by Freud, that of *idealization*, that of the ego ideal.’ He adds then that in the criss-cross [between field of Lust and field of *Ich*] *the unary trait comes to function in the field of Lust*, in the field of primary narcissism, which is ‘the fundamental mainspring for the ego ideal’. He showed how the two fields intersect (*op. cit.*, 10 June 1964). It is the relation between ego ideal and ideal ego. The singularly different third identification is introduced by a process of *separation* involving object a.

<sup>72</sup> But, it was not an imaginary process. And it had symbolic effects. Only the agent was imaginary (about the

As for the third form of identification Freud had not based it on any emotional link, any ‘object relation;’ it rather created that link. Lacan singled it out as identification to desire, hysterical identification. It supposes that we have already situated desire as ‘supposing (*supposant*) and underlying (*sous-jacent*) the articulation of the subject to the signifying chain, ‘insofar as that relation profoundly modifies any rapport the subject entertains with each one of the objects of its needs’.<sup>73</sup>

It is here that a certain kind of logic is needed, and Lacan will use logic now, a special logic, an *elastic logic*, because the logic of classes cannot describe the articulation between subject and structure in Freud’s three identifications.

‘The three identifications do not probably form a class. However, if they can take the same name that the shadow of a concept confers to them, it is up to us to account for the . . . knowing already that it is on the level of the particular that the universal function arises for us.’<sup>74</sup>

Lacan will use the three registers to account for identification, a trinity that he had already introduced with his 1953 Lecture ‘the symbolic, the imaginary and the real.’ He underlined

---

totemic meal, see Freud, S. 1912-1913, S.E. **13**, 141-143; S.E. **18**, 105). Lacan developed Freud’s first identification in his Seminar *L’insu que sait de l’une-bévue s’aile à mourre* (1976-1977, Book XXIV), and presented it using the topology of the Torus with a cut and turned inside out. With that topology Lacan addressed the question of the so-called ‘internal’, the question of ‘introjection’, because ‘even Freud talked of ‘endo-psyche’. He also asked the question: ‘what identification - which crystallizes into identity- had to do with that internal’ (Seminar Book XXIV, op. cit., 16 November 1976).

<sup>73</sup> Lacan, J., *Identification*, Seminar Book IX, 13 December 1961, 51. Freud, S., (1921c), S.E. **18**, 107: For the third identification Freud said: ‘The mechanism is that of identification based upon the possibility or *desire* of putting oneself in the same situation...The sympathy only arises out of the identification... The identification by means of the symptom has thus become the mark of a point of coincidence between the two egos which has to be kept repressed.’ (ibid.)

<sup>74</sup> Lacan, J., *Identification*, 13 December 1961: 51. See also session 21 February 1962, 105-106ff where Lacan introduced ‘the paradoxes of the appearances of the object as metonymic’, which the paradox of Russell, could account for.

that identification takes place within the structure and the structure belonged to the symbolic register.<sup>75</sup>

So, the subject was introduced in the structure -of language- by the unary trait and owed its permanence to it, which repeats itself never the same, always different. The Otherness of the trait ensured that there was no tautology, and it equally ensured that repetition was no eternal return of the same.

The best surface to show this was the topological surface of the Torus, in which we can show the subject's *demand* following a circular trajectory around an internal void, object *a*. 'This cycle repeats itself . . . either exactly the same or with minute differences...' <sup>76</sup> The *repetition* of the symptom substituted for a repressed signifier of the subject. When a certain cycle of behaviour returned, there we had the reminder for the 'trauma'. <sup>77</sup> But, the scene of the trauma was not repressed, the scene was there, played again on the stage; what was repressed was the signifier, 'the number so and so', the number of that cycle of behaviour which is repeated in the scene. Thus, in a hysterical crisis:

'It is because something originally happened, which is all the mystery of the trauma, that is, once something took place which took thence the form 'a', which within the complex repetition of behaviour . . . is there in order to bring back that sign.'<sup>78</sup>

---

<sup>75</sup> Ibid. 'Topology is the structure', Lacan said in the *Etourdit* (1973), for which the borromean knot was proposed as the most suitable paradigm. In Seminar Book XXIV, *L'Insu que sait de l'une-bévue s'aile à mourre*, (1976-1977), he said that 'the foundation of the three registers were proper names in Frege's sense'.

<sup>76</sup> Lacan, J., *Identification*, 13 December 1961, op. cit., 55.

<sup>77</sup> Ibid., 56. When Freud abandoned his theory of the trauma, and turned to the predisposing causes of neurosis, he used the concepts of frustration and privation, which Lacan will introduce in the Seminar here (Freud, S., 1912, *Types of Onset of Neurosis*, S.E. 12, 231-232).

<sup>78</sup> Lacan, J., *Identification*, 20 December 1961: 57. At the end of the session the editor took also into account the versions of Cholet, M., Conté, C.: 'If the repetition of a symptom has a meaning for us, . . . *what repeats itself is there not even only in order to fulfill the natural function of the sign representing a thing, but the thing which is actualized is there in order to make present as such the absent signifier, that this action has*

There ‘only the number is lost for the subject’, there . . .

‘. . . this structural embrace of something which is radically inserted in the living individuality with that signifying function that we are in the analytic experience, *Vorstellungsrepräsentanz*: this is what is repressed, this is the lost number of that behaviour.’<sup>79</sup>

Let’s take Freud’s case in the ‘Project’ (1950a [1895]), Part II, The hysterical *proton pseudos* (S.E. 1, 347): A young woman suffers from a compulsion, a phobia to go into a shop *alone*. The analysis of the symptom offers a glimpse into the unconscious processes at stake, the sexual determination of the symptom and the defence on the level of the ego, which leads to repression. Freud notes that from all the unconscious and repressed material, one signifier only passed over to conscious level, ‘clothes’ which Freud calls a ‘symbol’. But it plays no role whatsoever in the construction of the symptom. Lacan asks where is the subject in all that: ‘Is it in the radical, living individuality, in the pure sufferer of that capture by the signifier, is it in the organism aspired by the effects of “it speaks” . . . Or, can it be in the other end, identified with the very play of signifiers?’<sup>80</sup>

The function of the subject is neither in the one (the play of the signifiers) nor in the other (the living immanence), but would it be enough to say that it is between the two, in the ‘*entre-deux*’, between the idealizing effects of the signifying function and that living

---

*become.*’

<sup>79</sup> Ibid. Miller, J.-A., ‘The six paradigms of *jouissance*’, in *La Cause Freudienne*, no 43, Paris 1999: ‘Repetition is the return of a signifier or a symptom involving *jouissance*. . .’

<sup>80</sup> Ibid.: ‘Where is the subject in all that?’ Is it only identifiable with the play of the signifier? ‘Is it only the subject of discourse . . . condemned to . . . live in that sort of a mirage which results in that duplication, which makes him not only to speak everything he lives, but to live his being by speaking it, while what he lives is inscribed in an *επος*, a saga woven all along with his act?’

immanence, which some easily confuse with the drive?

This is the question which Lacan answered in this Seminar with the unary trait. He reminded, as an example, Little Hans' dream of the crumpled giraffe. In short, in the dream, there is the big living giraffe, and there is the little giraffe, the one which is made of paper and therefore can be crumpled. We can use them as imagos, as symbols or signs, the big giraffe is the mother, and the small giraffe is the little sister, and the relation of little Hans to the giraffe of the dream is answered with family rivalries. But, Lacan found something else there. The little giraffe, the crumpled one, has the function of a signifier. Its introduction in the psychical dialectic at a critical moment allows a minimum *anchoring* for the subject. The phobia itself is an artifice, as 'it introduces a signifier allowing the subject not to be totally at the mercy of the maternal whims'. It is the unary trait as an anchoring point (*point de capiton*). Little Hans's analysis shows us the tension between these two extremities of the subject. The big giraffe is definitely the mother, the mother as 'this immense phallus of desire, with its long neck ending in a voracious beak'. In the other end there is a crumpled little giraffe, a paper surface. The big giraffe shouts until it tires of it, and Hans takes possession of the little giraffe. All this illustrates the mechanism of identification to the signifier. This is Hans' defence against the original captivation by the mother's world.<sup>81</sup>

---

<sup>81</sup> Lacan, J., *Identification*, 20 December 1961: 61; *The Object Relations* (1956-1957), Seminar Book IV, 27 March 1957.



## **I. Modes of identification bordering the real; Lacan's "conjuncture" on the origins of writing.**

In the final session of year 1961 (20 December), and continuing in the first session of year 1962 (10 January) of Seminar IX, after he introduced the theme of the function of the signifier in the subject's identification, Lacan paused for a while to develop, as a counterpoint, the function of the proper name.

By linking the proper name to the letter, and by linking the letter to the subject's coordinates of identification, Lacan reached a hypothesis – a 'conjecture' – on the origins of writing in which writing became the 'conjuncture' between symbolic and real, his theory of the letter, the littoral of the real for the subject.

'There is a subject which is not confused with the signifier as such, but deploys itself in that reference to the signifier with traits, with characters which can be perfectly articulated and formalized, and which should allow us to grasp, to discern the *idiotic* character ....[it is the Greek word] of the proper name as such.'<sup>82</sup>

He first looked for an answer to the question 'what is a proper name?' in the linguist Alan H. Gardiner whose essay 'The Theory of Proper Names, a controversial essay' (1940) had its origins on a critique of Russell's theory of the proper name as it figured in the latter's paper 'The Philosophy of Logical Atomism' (1918-1919).<sup>83</sup> We met the proper name on our way to the second form of identification to the unary trait. We heard him from the start

---

<sup>82</sup> Ibid., 64.

<sup>83</sup> A.H. Gardiner was a linguist known for his works on *Egyptian Grammar*. His *Theory of Proper Names, a Controversial Essay*, Oxford University Press, London, 1940, was written as a reply to Russell's theory of the proper name.; Russell, B., 'The Philosophy of Logical Atomism', *The Monist*, 1918-1919, Chicago. Russell's definition of the proper name was: 'a name is *a word for particular*, a word for designating particular things without any description' But, as Lacan noted, Russell admitted as proper names descriptions such as the pronouns *this*, *that*, or even *a point on the blackboard*. That was a paradox. For Lacan's critique of Russell for including the proper name in the denoting phrases in his essay 'On Denoting' (1905), cf.: This thesis, Chapter 5, p. 283, note 62)

of Seminar Book IX underlining the function of the signifier in the subject's identification, as the 'anchoring point' (*point d'amarre*) for the subject, for example, in the case of Little Hans his unconscious identification to the crumpled giraffe, the unary trait, the ego ideal. But there was something else. There was the function of the proper name as a letter and it was there that Lacan paused for a while.<sup>84</sup>

The proper name had something to do with the subject itself and its 'real' dimension. It was not grammar's substantive. It was not the demonstrative pronoun either. Alarmed by Russell's argument which finally took away any particularity from the proper name, Lacan turned to the linguist Gardiner who had argued in favour of the proper name's singularity as based on the sound. Gardiner highlighted the ancient Greek definition of the proper name given by the grammarian Dionysius of Thrace, which differentiated between *common* name, what we call substantive, and *idion* name, what we call *proper* name, ιδιον as opposed to κοινον.<sup>85</sup>

Based on that definition and with a reference to John Stuart Mill's theory of the proper name as a meaningless mark, Gardiner had argued that it is not so much the absence of meaning that distinguishes the proper name -after all proper names can sometimes have a meaning- but the preference we give to their sound. We do not pay attention to their meaning because we are only interested in their sound.

<sup>84</sup> Lacan, J., *Identification*, op. cit., 59.

<sup>85</sup> Dionysius of Thrace, *Grammar*, 634b, [p. 25 of the Uhlig publication], Leipzig 1885). 'Όνομα εστι μερος λογου πτωτικον, σωμα η πραγμα σημαινον, σωμα μεν οιον λιθος, πραγμα δε οιον παιδεια, κοινως τε και ιδιως λεγομενον, κοινως μεν οιον ανθρωπος ιππος, ιδιως δε οιον Σωκρατης. 'Name is a declinable part of discourse, signifying either a body or a thing[activity], a body such as *stone*, an activity such as *education*, [and] said[used] either as a *common name* or as a *proper name*, a common name such as *man*, *horse*, or a proper name such as *Socrates*.

But, for Lacan, even this observation failed to bring up the singularity, the ‘idiotic character’ of the proper name which is not to be confused with the ‘particular’ of Russell. What Russell did not see in the proper name was its function as *letter*.<sup>86</sup> But, Gardiner too failed to articulate the name with the function of the subject, not as the concrete psychological subject, but as articulated to the signifier without being confused with it.

But, thanks to the linguist we found the proper name as a ‘pure signifier.’ This is what Gardiner’s definition means: ‘a proper name is something which is valid by its function as distinctive sound material’<sup>87</sup> But Lacan went further to link the name with the letter: ‘. . . there cannot be any definition of the proper name, unless we perceive the relation of the *naming emission* with something which, in its radical nature, belongs to the order of the *letter*.’<sup>88</sup>

---

<sup>86</sup> Concerning the function of the letter, there are two papers by Lacan in the *Ecrits* (1966: 1) Seminar on “The Purloined Letter” (1956), opening the volume, to which a ‘Parenthesis of Parentheses’ was added in 1966. 2) ‘The Instance of the Letter in the Unconscious’ (1957), a landmark contribution to the Journal *Psychoanalysis and Literature*. The former was a commentary on Poe’s *Purloined Letter* and was given as an aside in Lacan’s Seminar *The Ego in Freud’s Theory and in the Technique of Psychoanalysis*’ (1954-1955, Seminar Book II, 26 April 1955). It was prompted by a re-examining of Freud’s ‘Beyond the Pleasure Principle’ (1920g). It concerned repetition, and in Lacan’s own words ‘the insistence of the symbolic chain’ and the ‘existence of the subject of the unconscious’. A second version was written mid- May to mid-August 1956, and published in *La Psychanalyse*, No 2, 1956. A third version with additions and extensions appeared finally in the *Ecrits* (1966). The latter, ‘The Instance of the Letter in the Unconscious’, was written in May 14-26, 1957 and published in *La Psychanalyse*, No 3, 1957. It was first given as a talk to the *Federation of Students of Philosophy* at the Sorbonne on 9 May 1957. Inspired by Joyce’s equivocation *letter/litter* Lacan, in 1971, wrote another remarkable paper on the theme of the letter as his contribution to the Journal *Littérature*. Beyond what he had already developed—that the letter is distinguished from the signifier which it carries and that it always arrives at its destination- he now develops another aspect of it. *Lituraterre*, as the title went, was about the letter as litter, and moreover as littoral, and as the edge of a hole (*Littérature*, No 3, October 1971, Larousse; reprinted in *Autres Ecrits*, Seuil, Paris 2001).

<sup>87</sup> Lacan, J., *Identification*, 10 January 1962: 69: ‘The function of the subject in language is to name by its proper name.’

<sup>88</sup> *Ibid.*, 65.

Freud had already formulated the hypothesis of a process of writing in the psychical apparatus, he described it as successive ‘inscriptions’ (*Niederschrifte*) of ‘signs’ (*Zeichen*), first of perception (*Wahrnehmungszeichen*), and of indexation of reality (the ‘Project’s  $\omega$  system), a selection not involving consciousness, which he later replaced with the ‘representatives of representation’ (*Vorstellungsrepräsentanzen*), second of unconscious signs (*Unbewußtzeichen*), and finally a third transcription of ‘preconscious signs’ (*Vorbewußtzeichen*), which was rather a re-transcription (*Umschrift*), a translation. There were at least three, probably more, of those registrations according to the ordering of the psychical material that Freud presented in his Letter of 6 December 1896 to Fliess, known as ‘Letter 52’.<sup>89</sup>

In Février’s ‘History of Writing’ (1959), which Lacan read at the time of its publication<sup>90</sup> he found prehistoric signs, marks, traces on pebbles and stones which looked like ideograms. These signs were in a way ‘signifiers’ but not yet proper writing, but they were not ideograms, in which the figurative was effaced. At the same time the prehistoric man had the use of vocal emissions. When those signs were read, it is then that writing started. The signs became ideograms, hieroglyphics, and other forms of figurative writing, then when the figurative was effaced, or, as we could say, repressed, or rejected, the sign with its phonetic value could be transferred to other objects, to other languages, to other signifying contexts; it became then a letter.

<sup>89</sup> Freud, S., *Letter 52*, S. E, **1**, 233-239; Masson, J. M., *The Complete Letters of Freud to Fliess*, op. cit., 207-214.

<sup>90</sup> J.G. Février’s *L’ Histoire de l’Ecriture*, Payot 1959. Lacan also read the collective work *L’homme avant l’écriture*, edited by A. Veragnac, and published by Armand Colin in 1960.

Lacan's "conjecture on the origins of writing" was, as Jean Allouch suggested, an important counterpoint to Lacan's formulation 'the unconscious is structured as a language', one that necessitated logic in order to be formulated, logic as 'the science of the real'. This theory was there to 'prevent that speech becomes an object of cult'<sup>91</sup> :

'Writing as material, as luggage, following a certain process which we call *the formation of marks* . . . the *signifiers*, was waiting there in order to be *phonematized* . . . and . . . when this happens, it is then that it starts to function as writing . . .'

<sup>92</sup>

The signs, the traits are made of bits which can be transferred and become the phonetic support of other signs. Thus progress in writing is achieved. What the advent of writing represents is that something which was already writing – if writing is singling out the signifying trait- by being *named*, comes to support the famous sound, on which Mr Gardiner put the stress concerning the proper names. The unconscious structure is based on the adjoining of a vocal emission with a sign.<sup>93</sup> So, Lacan's conjecture on the origins of writing can be summed up:

'. . . there is a time historically defined, a moment when something is already there to be read with language, when there is no writing yet. With the reversal of this relation, and the relation of *reading* to the sign writing is born, which serves to connote the phonemes.'<sup>94</sup>

---

<sup>91</sup> In Seminar Book V, *The Formations of the Unconscious*, 25 June 1958, we have Lacan's structural definition of the unconscious: 'the unconscious is structured as a language.' In Seminar Book VIII, *Transference*, session 31<sup>st</sup> May 1961, he says that 'there is no meta-language'. According to Jean Allouch a major shift took place with Lacan's "conjecture" of writing'. In the place of the opposition *language-object* versus *metalanguage* as found in Russell's theory, Lacan brings the opposition between *writing* which comes in the place of the language/object and *speech*, which is meta-language, a this has consequences for the theory of the unconscious. 'If what makes instance is the letter and not the signifier, then, saying "the unconscious is structured as a language" sends us rather to grammatology, which does not exist, and not to linguistics (Allouch, J. 'La conjoncture de Lacan sur l'origine de l'écriture', *Littoral*, No 7-8, Paris, 1983, 5-26).

<sup>92</sup> Lacan, J., *Identification*, 20 December 1961: 67.

<sup>93</sup> *Ibid.*

<sup>94</sup> Lacan, J., *Identification*, 10 January 1962: 73. The progression seems to be from an object to its mark which is not yet writing, then to reading the marks/signs with language then transfer phonemes to other languages. Writing is born, leaving always behind the trace of the subject.

The proper name has a special function in the unconscious structure of the subject: it identifies, specifies the rooting of the subject as such and is linked ‘not to phonematization as such, not to the structure of language, but to that which, in language, is ready to receive the information of the trait’.<sup>95</sup> The proper name is on the edge of the real, it is letter and littoral, edge of the hole, as Lacan will say in 1971. It is supposed to be ‘an archaic point’, at the origin of the unconscious. Thus: ‘the subject who cannot but always go forward in the chain, in the deployment of statements . . . , always elides something which is, properly speaking, what he cannot know, that is, the name of what he is as subject of the enunciation.’<sup>96</sup>

In the act of enunciation is rooted the latent nomination of the subject is the first kernel, the signifier around which the unconscious will be organized as a turning chain of signifiers. It is a formal chain, a logical chain which does not follow exactly the rules of modal logic.<sup>97</sup>

### **J. Privation, Frustration, Castration**

Turning towards the pole of the object in the process of identification will lead Lacan from the logic of propositions to the logic of object *a*, which is based on a logic of privation. The

---

<sup>95</sup> Ibid.

<sup>96</sup> Ibid.

<sup>97</sup> Lacan, J., *Identification*, 20 December 1961: 68. As Lacan reminds us, the deciphering of Egyptian hieroglyphics became possible only when the names of Ptolemy and Cleopatra were read on the Rosetta stone, thanks to their parallel transliteration in the Greek and Latin part of the inscription. A name is a writing which cannot be translated, it can only be transliterated. From one language to another its structure remains the same, and the sound structure has to be respected ‘because of the affinity of the proper name with the mark.’ (Gabay’s version continues: ‘because of the direct attachment of the signifier to a certain object’. Cholet’s version has: ‘because of the direct designation of the signifier as object’. Gabay’s version is more accurate. In Seminar XXI, *Les non-dupes errent* (1973-1974), 20 November 1973, Lacan said that ‘the signifier is a sign addressed to another sign; it is what makes sign to another sign, and this is why it is a signifier’. However, concerning the letter and writing he is more nuanced: He puts writing on the side of the real: ‘It is on the side of writing what I try to question when I say that the unconscious is something in the real’ (Lacan, J., *Les Non-dupes errent*, Seminar Book XXI, 21 May 1974).

three matrices of negation, *Privation Frustration Castration*, will be confronted to the logic of propositions, especially as it was modified by Peirce, and Lacan will show how the subject is affected by them.

The concept of ‘privation’ had appeared in Freud linked to ‘frustration’. We find a similar trinity in Freud’s work. Their relation seems to pass through ‘prohibition.’ In ‘The Future of an Illusion’ (1927c) Freud will describe ‘the fact that an instinct cannot be satisfied as *frustration*, the regulation by which this frustration is established as a *prohibition* and the condition which is produced by the prohibition as *privation*.’<sup>98</sup> ‘Frustration’ was described earlier by Freud as a cause predisposing to neurosis in his paper ‘Types of Onset of Neurosis.’ (1912c). ‘Frustration’ was due to limitations imposed by civilization and internalized by the subject usually in the form of abstinence, inaction, or inhibition: ‘The subject becomes neurotic as soon as this object [of love] is withdrawn from him without a substitute taking its place.’<sup>99</sup>

In Lacan *Privation, Frustration, Castration* found a logical, modal formulation around the notion of ‘lack of the object, lack which is experienced because of the internal difficulties linked to the access to the object of satisfaction, the sexual object. The logical table was first drawn in Seminar Book IV, *The Object Relations* (1956-1957), session 12 December 1956. Lacan developed *frustration* first which was experienced early by the child in his/her relation to the mother. In January 1957 his talk centred on the theme of feminine homosexuality. Having or not having the phallus was for Freud the central question during

---

<sup>98</sup> Freud, S., 1927c, S. E. **21**, 10.

<sup>99</sup> Freud, S., 1912c, S. E. **12**, 231.

the so-called phallic phase, for both sexes. Freud called this criterion: primacy of the phallus. So, although *frustration* (not having the object of satisfaction) was already experienced early in life, it took its full meaning at that stage. Frustration was an imaginary dam, a result of the mother's omnipotence. The object in frustration was real, it was the breast first, the penis second. *Privation* could appear as a mishap during the time of the Oedipus complex, for the little girl, when the frustration for having not been given the penis by the mother, was replaced by the deception of not receiving a substitute from the father in the form of a child, in fantasy, of course. Lacan underlined that this could only be valid for a subject who articulated her experiences in a series of 'symbolic resonances', or substitutions. As a result of that accident, the subject was itself affected by or as lack, as object falling. In the case of the young homosexual, she attempted suicide.

Lacan's table of *privation, frustration, castration*:

AGENT	MANQUE D'OBJET	OBJET
Père réel	Castration	imaginaire
Mère symbolique	Frustration	réel
Père imaginaire	Privation	symbolique

Lacan's present the logic of the lack of object in Seminar Book IV (1955-1956), *The Object Relations*. The table was completed in session 13 March 1957 (Cf.: This thesis, Chapter 6, p. 343



The three modalities of lack reappeared briefly in Seminar Book V, *Formations of the Unconscious* (1957-1958), in session 12 March 1958. 'Frustration' is an imaginary operation, which involves a *real object* (breast, penis) and a *symbolic agent*, the mother (as present/absent). 'Privation' is a *real operation* (he will situate it in the Real); it is what the girl experiences for not having (a child from the father), 'even if it was never a question that she did'. The *agent* is imaginary, the *object* is *symbolic* (the child is the symbol of what she is really frustrated for not having, the phallus). Castration finally *symbolically amputates* the subject of an *imaginary object*. Lacan underlined that *privation* in the case of the girl leads to identification with the father. She does not become the father, though, but the *ego ideal*.<sup>100</sup>

In Seminar Book IX, *Identification* (1961-1962) 'privation' comes into play early, via negation as involving, manifesting the subject. Freud defined negation as an important step preceding the recognition of the repressed content of thoughts. We find that in his paper 'Negation' (1925h), 'Negation is a way of taking cognizance of what is repressed.' It is a form of judgment and as a negative judgment it is 'the intellectual substitute of repression.'<sup>101</sup>

For Lacan, negation seems to have a special relation with the modes of appearance of the subject and also of the subject realizing his own position in the structure, as manifested in the treatment. The two particles of negation '*ne pas*' separated from each other, as in the

---

<sup>100</sup> Lacan, J., *Formations of the Unconscious* (1957-1958), Seminar Book V, 19 March 1958.

<sup>101</sup> Freud, S., (1925h), S.E. **19**, 236-237.

French, seem to play a significant role in these realisations; on its own the expletive *ne* is full of subjective meaning, while the second part of negation, *pas*, which can signify ‘not at all’ (*guère*), ‘nobody’ (*personne*), seems to exclude a piece of reality and for that reason called ‘forclusive.’<sup>102</sup> But in phrases such as, ‘*je crains qu’il ne vienne,*’ the expletive *ne*, supports the subject of the enunciation. ‘Does it mean that we have to make out of *pas* something which brutally connotes the pure and simple fact of privation?’<sup>103</sup>

Lacan argued that he could show the different forms of negation and not only the dichotomy between *ne* and *pas*, with the matrices of *privation*, *frustration*, *castration* taken from our psychoanalytic clinic, and with a logical table far better suited to psychoanalysis than Aristotle’s *Square* or Kant’s *table of Nothing* (*nichts*).<sup>104</sup>

Lacan had to turn first to ‘the great philosophers’ Aristotle and Kant, in his research ‘which always returns to the radical knot of desire’, and to contrast their approach to the psychoanalytic approach. He introduced the logic of privation, frustration, castration, starting from privation because ‘it is the logic of the object of Psychoanalysis’. In his ‘table of the division of the concept of Nothing’ (*nichts*) Kant had placed in no. 1 ‘the empty concept without object’, the ‘thought-entity’ (*leerer Begriff ohne Gegenstand, Gedankending) ens rationis*, as not to be counted amongst the possibilities, but not impossible, and opposite it in no. 4 the ‘empty object without concept’, the ‘non-entity’ (*Unding*), *nihil negativum*, the impossible. 1 and 4 were both empty concepts. In places no.

<sup>102</sup> Pichon, E. & Damourette, J., *Des mots à la pensée. Essai de grammaire de la langue française*, ed. d’Artrey, publié avec le concours du CNRS, vol. 1, chap. VII, *La négation*.

<sup>103</sup> Lacan, J., *Identification* (1961-1962), 17 January 1962: 87.

<sup>104</sup> Lacan, J., op. cit., 28 February 1962; Kant, I., ‘Critique of Pure Reason’, unified edition (1781 and 1787), tr. by Pluhar W., Hackett Publishing Company, Cambridge, 1996.

2 and no. 3, respectively, he placed the ‘nihil privativum’ and the ‘ens imaginarium’, both empty data for concepts, the first an empty object, the second an empty intuition without object. Kant notes at the end that both 2 and 3, ‘negation and mere intuition without something real, are no objects.’<sup>105</sup>

### Kant’s Table of Nothing

#### NOTHING

As

1

Empty concept without object,

*ens rationis*

2	3
Empty object	Empty intuition
Of a concept	without object
<i>Nihil privativum</i>	<i>ens imaginarium</i>

4

Empty object without concept

*Nihil negativum*

---

<sup>105</sup> Kant, I., (1781), ‘Critique of Pure Reason’, 1996, 345

Lacan's general table of negation with *privation, frustration, castration* can be confronted with the tables of negation in Aristotle and Kant. Lacan put the emphasis on negation. The emphasis on the opposition between affirmatives and negatives was not developed by Aristotle.<sup>106</sup>

Here we show three versions of Aristotle's opposition of propositions, known as Aristotle's square

1. Expressed with quantifiers

<b>A</b>	<b>E</b>
$\forall x Fx$	$\forall x \neg Fx$
$\exists x \neg Fx$	$\exists x Fx$
$\exists x Fx$	$\exists x \neg Fx$
$\neg \forall x \neg Fx$	$\neg \forall x Fx$
<b>I</b>	<b>O</b>

The letters **A**, **E**, **I**, **O**, have designated four types of propositions since the middle ages.

<sup>106</sup> Lacan, J., (1961-1962) *Identification* (Seminar Book IX, 17 January 1962, p. 89). The syllogisms were developed in *Prior Analytics*, the third book of Aristotle's *Organon*. The propositions were developed in *On Interpretation*, the second book of *Organon*. The universal negative(A) –*στερητικη καθολου*- came first in the order of the square, the particular negative(E), second, followed by the particular affirmative(I), third, and the particular negative (O), fourth. *Καταφασις* is the Greek word for Affirmation(A), and *Αποφασις* for Negation(N). Aristotle was not interested in particulars, but in the universals and the singular. The particular emphasis on the propositions' affirmative and negative functions was developed later by Averroes [Latin name of Ibn Rushd] (1126-1198 A.D.). Here are some of Aristotle's examples: 'Εστιν ανθρωπος-ουκ εστιν ανθρωπος', there is a man, there are no men, 'εστι πας ανθρωπος all men - ουκ εστι πας ανθρωπος, not all men. The coupling of affirmative and negative propositions: εστι δικαιος ανθρωπος, ουκ εστι δικαιος ανθρωπος, is complemented with 'εστιν ου-δικαιος ανθρωπος, ουκ εστιν ου-δικαιος ανθρωπος. (Aristotle, *On Interpretation*, second book of the *Organon*, 19b, Loeb Classical Library, Aristotle Vol. I, 1938).

The Universal Affirmative, **A**, the Universal Negative, **E**, the particular affirmative, **I** and the particular negative, **O**. They were not part of Aristotle's text, neither was the square.

The quantifiers are used in modern, formal logic.

## 2. The relations between the propositions

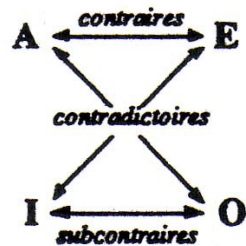

This square is known from scholastic logic, it shows the relations between the four kinds of propositions. First between **A** and **E** the universal propositions, first the affirmative ( **A**, *affirmo*) then the negative ( **E**, *nego*); they are *contraries*. Then between **I** and **O**, the particular propositions, first the particular affirmative, **I**, then the particular negative, **O**; they are *subcontraries*. On the other hand, **A** and **O**, **E** and **I**, are *contradictories*.

Aristotle recognized three forms of statement which affirm a predicate for a subject, the singular, the universal, and the particular. The first opposition is between Universals and particulars, the second between Affirmatives and Negatives. Their combination 'yields a fourfold classification of general statements according to the following scheme in which each type is illustrated by the example below:

3. The square clarified

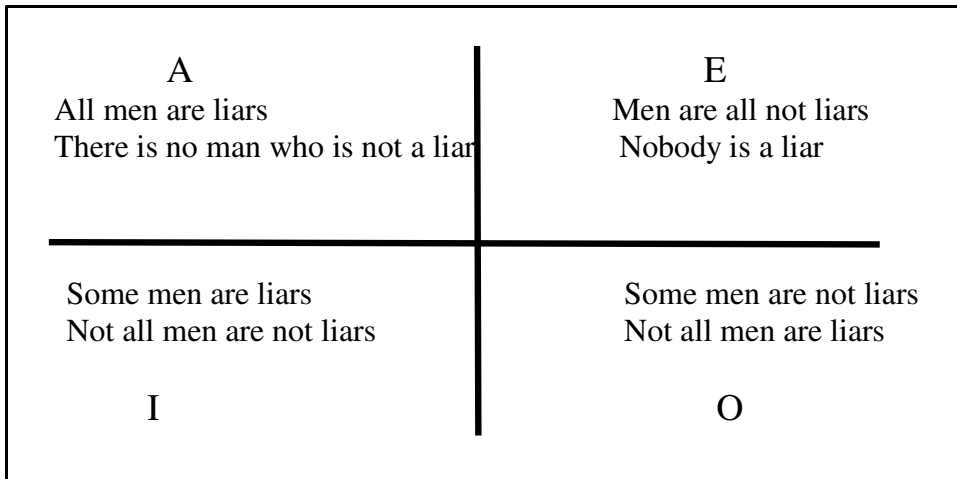

The American philosopher C.S. Peirce thought that all logic and not only its more general statements –as was the case in Boole’s Mathematical Analysis of Logic (1847) – must be able to be presented in algebraic form. He presented his logic of propositions in a series of papers written between 1870 and 1903, now available in the third volume of his Collected Papers (1960), Cambridge Harvard University Press.

Peirce’s Quadrant

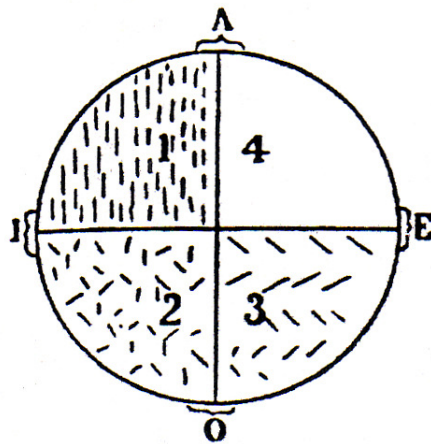

Peirce, C.S (1960), Collected papers, Vol. II, Book III, Chap. 1. Cf.: This thesis, Chapter 6,

p. 344

Lacan used Peirce's Quadrant as a model for reflection on the logic of the unary trait (Seminar Book IX, Identification, Session 17 January 1962). In Peirce's Quadrant Figure 1 The function 'trait' will fulfill that of the subject, and the function 'vertical' which is chosen simply as a support, that of the attribute. Quarter 1 says: 'all traits are vertical' and quarter 4 says: 'there are no traits', quarter 2 says: some traits are vertical, and quarter 3: no traits are vertical.

In classical logic since the time of Apuleius who wrote an essay about it, it was thought that in the logic propositions the subject was considered from the point of view of *quality* and the attribute from the point of view of *quantity*. It was like saying: in the one there are many, or all, or no one.

Peirce disputed this categorization: 'Universals and Particulars, he said, differ in *Lexis*, Affirmatives and Negatives in *Phasis*. Λεξις, is an *I say, I chose*, involving the function of choice, of extraction of a signifier, according to Lacan's comment. The Affirmatives and Negatives on the other hand, are second in order following *lexis*, bring in the function of speech, of a personal involvement: 'I bet on the existence of something which has been put in question by the initial *lexis*'. *Phasis* is a saying in the sense of 'What do you say? Yes or No?' καταφασις, affirmation, or αποφασις, negation.

Peirce's *Quadrant* according to λεξις and φασις (Cf.: This thesis, Chapter 6, p. 345)

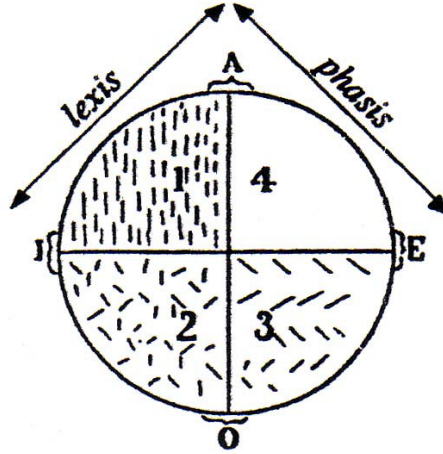

‘The distinction between Universal and Particular propositions is said to be the distinction in *Quantity*; that between Affirmative and Negative propositions the distinction in *Quality*. Such is the traditional terminology’.<sup>107</sup>

In session 24 January 1962, Lacan will turn to the function of object *a* in the subject’s identification, following his lecture ‘*De ce que j’enseigne*’ -given the previous evening, 23 January 1962, where he developed Freud’s ‘Theme of The Three Caskets’ (Freud, S., 1913f, S.E. 12, 291)<sup>108</sup> and he will continue developing it as well as presenting the topology of it.

But first he introduced object *a* as metonymic, and located outside, in the analyst, first of all.

<sup>107</sup> Peirce, C., *Collected Papers*, Cambridge, Harvard University Press, 1960, Vol. II, Book III, Chap. 1. Par. 2 and 3. Lacan, J., *Identification*, 17 Jan. 1962: 91, 92, and (for Peirce’s par. 3), Appendix 5, 345.

<sup>108</sup> Lacan, J., op. cit., 24 January 1962: 21, and 28 February 1962.



### K. A short history of the unary trait

The unary trait was again defined in *The Four Fundamental Concepts of Psychoanalysis*, Seminar Book XI(1964), 3 June 1964. It was the signifier which coupled with another became the binary signifier and caused the subject's division or alienation. Freud called it *Vorstellungsrepräsentanz* (the representative of the representation):

‘The subject appears first in the Other, insofar as the first signifier, the unary signifier, emerges in the field of the Other, and represents the subject for another signifier, which has as its effect the *aphanisis* of the subject. Hence the division of the subject –when the subject appears somewhere as meaning, he is manifested elsewhere as ‘fading’, as disappearance.’<sup>109</sup>

For Lacan, *Vorstellungsrepräsentanz* is the name for the binary signifier, the instrument of alienation which causes the subject's division. <sup>110</sup> Lacan's axiomatic definition of the

---

<sup>109</sup> Lacan, J., (1964), *The Four Fundamental Concepts of Psychoanalysis*, Seminar Book XI, 3 June 1964, Seuil, 1973, 199 (Sheridan, 218). *Signifier one* (S1) became later one of the four terms of the structure of Discourse as the Master Signifier; Seminar *The Other Side of Psychoanalysis*, Book XVII, 1969-1970, 10 December 1969). In Seminar *From an Other to the other (d'un Autre à l'Autre)* Book XVI, 1968-1969, 11 June 1969, it was defined as signifier external to the field of the Other, unconscious, standing alone but attracting what is called now S2, the battery of signifiers, defined as knowledge (*savoir*). In Seminar *Encore* (Book XX, 1972-1973, 19 December 1972): ‘One (*un*), in front of the signifier has the use of the indeterminate article. It supposes already that the signifier is capable of collectivisation, that one can make a collection of them, speak of them as something which can be totalized.’ In Seminar Book XXI, *The Names of the Father* (1973-1974): ‘Signifier one, S1, on which the master discourse rests, means nothing else than that the signifier exists, that it is a multitude (*un tas*), but that each one of them is any signifier (*un quelconque*). Upon that fact rests the existence of One: that there is a signifier which is not unique, but on its own’ (ibid., 12 February 1974).

<sup>110</sup> Lacan will say that *alienation* is not in the fact that the subject emerges in the field of the Other, but that it is in the alienating ‘*vel*’, in that division, which is shown in the topology of Euler circles (Lacan, J., 1964, Seminar Book XI, 27 May 1964: 191). One, plus one, plus one, plus one do not make four, this is where he tries to articulate the alienating ‘*vel*’ (op. cit., 3 June 1963). As for the process of *separation*, Lacan says he finds its origin in another identification ‘of a strangely different kind’, identification to desire: By separation the subject finds . . . the weak point of the primal dyad of the signifying articulation, in so far as it is alienating in essence’ (Seminar Book XI, 3 June 1964, op. cit., 218). ‘By the function of object *a* the subject separates himself off, ceases to be linked to the vacillation of being, in the sense of alienation.’ (17 June 1964: 257).

signifier, 'a signifier represents the subject for another signifier,' first presented in 'The Subversion of the Subject and the Dialectic of Desire' (1960) in the *Ecrits* (1966) was reiterated in *The Four Fundamental Concepts of Psychoanalysis*, 1964, Seminar Book XI (session 20 May 1964). The signifier unary trait 'emerges in the field of the Other'.

The division of the subject is caused by primary repression (*Urvedrängung*).

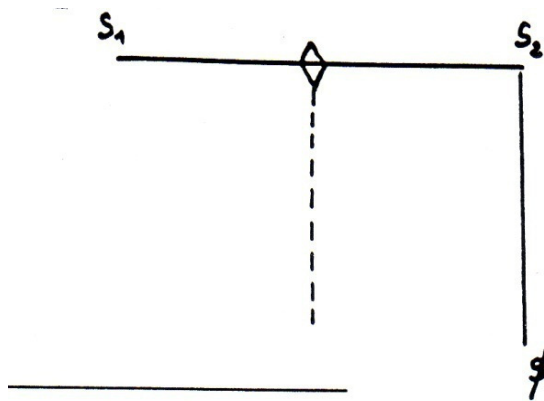

Lacan, J., (1964) *The Four Fundamental Concepts of Psychoanalysis*, Seminar Book XI, 198.

However, the relation to the Other is based on a loss on the side of the subject 'who was previously nothing if not a subject coming into being', but now 'solidifies in a signifier' (ibid., 27 May 1964, 198-199). Thus, the unary trait comes in the place of the subject and is coupled to the binary signifier. But, from having passed into the unconscious, the binary signifier will become 'the central point of the *Urvedrängung*'. The binary signifier, *Vorstellungsrepräsentanz*, becomes the point of attraction of all subsequent *unterdrückt*

signifiers (ibid., 3 June 1964, 218).<sup>111</sup>

In Seminar Book XVI, *D'un Autre à l'autre* (1968-1969) there are important developments concerning the relation between signifier 1, (the ego ideal) and object *a*: The unary trait is remembered but now looked from the angle of the relation between object *a* and *jouissance*. Repetition, which comes as a consequence of the loss of object, is essentially 'jouissance' involved in the effort of 'finding the object again'. It is recognized as a *mark*, but this mark 'introduces *-with jouissance-* the blemish from which the loss occurs'.<sup>112</sup>

We find in Seminar Book XVI, *D'un Autre à l'autre* (1968-1969), the metaphor of the empty mustard pot, a metaphor for the subject which Lacan first presented in Seminar Book IX (*Identification*). It has to do with the signifier as content of the empty pot. In the same Seminar the definition of the signifier remains unchanged, but Lacan articulates the signifier with something which has the possibility of some *jouissance* for the subject,. Via the structure of discourse, the subject is unified, 'not the unconscious subject, but the preconscious subject'. Signifier one ( $S_1$ ) represents the barred subject for signifier  $S_2$ . However, another signifier ( $S_3$ ) can have a relation to object *a* (the product of surplus-*jouissance*). The construction of the four discourses in the following Seminar, *The Other*

---

<sup>111</sup> In 'The Subversion of the Subject and the Dialectic of Desire in the Freudian Unconscious' (1960) Lacan proposed a similar development, about -1, the signifier which cannot be counted in the battery of signifiers. The subject, as a result, can be equaled to square root of -1, which is what the subject is missing (*manqué*) by emerging in the field of the Other. We signal however, that we find in this paper a distinction between the subject's division (*Spaltung*) due to the signifier and 'the moment of *fading* or eclipse of the subject due to the object in fantasy ( $\$ a$ ). (Lacan, J., 1966, *Ecrits*, 691[816]). In Seminar Book XI the two seem to coincide.  
<sup>112</sup> Lacan, J., *D'un Autre à l'autre*, Seminar Book XVI (1968-1969), 22 January 1969, Seuil, Paris, 2006, 121. Lacan introduced in this seminar the notion of *surplus-jouissance* (*plus-de-jouir*). 'The *surplus-jouissance* is a function of the renunciation of *jouissance* under the effect of discourse. It gives its place to object *a*.' J.A. Miller called this notion the fifth paradigm of *jouissance* (Miller, J.-A. 'Les paradigmes de la *jouissance*', *Revue La Cause Freudienne*, no. 43, Paris, 1999).

*Side of Psychoanalysis* (Book XVII, 1969-1970) represents the effort to link the *signifier* with *jouissance* and knowledge, and its development is carried on in Seminars *D'un Discours qui ne serait pas du semblant*, (Book XVIII 1970-1971), and *Ou pire* (Book XIX 1971-1972).

'A signifier represents the subject for another signifier' is the first formula, the second 'wants to mark that any other signifier in the chain, here perhaps S<sub>3</sub>, can enter in relation with something which is an object, object *a*...' (Seminar *D'un Autre à l'autre*, Book XVI, 13 November 1968, 22-23):

$$\begin{array}{ccc} S_1 & & \\ \text{----} > S_2 & & S_3 \diamond a \\ \$ & & \end{array}$$

In Seminar *D'un Autre à l'autre*, 'signifier one or *unary trait* is 'the mark of the gap which separates the body from its *jouissance*'. It is not said that it causes it, but that 'it aggravates it . . . it gives it its consistence'. Here Lacan refers to the relation of 1 and *a*, unary trait and *surplus-jouissance*.<sup>113</sup>

In Seminar *Ou pire*, (Book XIX, 1971-1972) Lacan remembers that he invented the unary

---

<sup>113</sup> *Surplus-jouissance* is another term for object *a*. (Lacan, J., *D'un Autre à l'autre*, Seminar Book XVI (1968-1969), 22 and 29 January 1969). In the same seminar Lacan argued: 'If in the signifier one, that is the unconscious, there is knowledge minus(-) truth, and this minus is marked as object *a*, it does not mean, however, that object *a* is the truth' (Seminar Book XVI, *D'un Autre à l'autre*, 5 March 1969). J.A. Miller used the expression 'a wedding between the signifier and *jouissance*' for this period of the *fifth paradigm of jouissance*, starting with Seminar XVI. (Miller, J.-A., 1999, 'The six paradigms of jouissance', op. cit., from Seminar *The Lacanian Orientation* (March and April 1999)).

trait in 1962 (he introduced it actually in his Seminar *Transference* in 1961) and now wants to see if it can be divided into two, talks about the *bifidité de l'Un*, thus different from 'being' ( $\epsilon\omicron\nu$ ) in the sense of the *One* in Parmenides' Poem. Lacan indicates that Plato said something different than the Eleatic philosopher in his *Parmenides*, namely that *there's of one* ( $\epsilon\iota\varsigma\ \alpha\nu\ \epsilon\sigma\tau\iota\nu$ , says Plato), if it partakes of the *eidōs* of monad.<sup>114</sup> 'Yad' lun', says Lacan and finds the Platonian 'eidōs' to be equivalent with his own 'real', or 'essence', or even better, 'existence'.<sup>115</sup> *Yad'lun*, the 'master signifier', is not semblance, he professes. It could signify union 'unien', the task of the Freudian Eros, life, as 1, or death (*Thanatos*), as -1, but it comes to signify the absence of sexual rapport.

In Seminar Book XX, *Encore*, 1972-1973, (19 December 1972), saying 'there is such a thing as One (*Y a d' l'Un*) leads Lacan to the signifier 'situated at the level of enjoying substance (*substance jouissante*) . . . the signifier as the cause of *jouissance* . . . corporizing the body in a signifying way...' According to J. A. Miller, in Seminar *Encore* (1972-1973) Lacan went as far as undermining his previous edifice. *Encore* is a complete overturning of the strategy of the four discourses where the signifier and *jouissance*, in the limited kind of *surplus-jouissance*, *a*, were connected. Here the signifier is presented by Lacan not as a representation, but as the 'sign of the subject', which is a return to Peirce, and a formula difficult to integrate in Lacan's definition of the signifier, until then.<sup>116</sup>

---

<sup>114</sup> Lacan, J., Seminar Book XIX, *Ou pire*, 1971-1972, 15 March 1972.

<sup>115</sup> Ibid

<sup>116</sup> Miller, J.-A, op. cit., 1999:24: 'In *Encore*, Lacan starts from the fact of 'jouissance', while until then his point of departure was language and speech, as communication addressed to the Other. In relation to language, to speech and the structure which supports it, it was a question of the capture of the living organism, and with discursiveness he went as far as positing an original relation between the signifier and jouissance.' But in *Encore* the concept of language itself is put into question and considered secondary, a derivative in relation to what Lacan will call *lalangue*, speech disconnected from the structure of language.

## CHAPTER 6

### CONTE'S CONTRIBUTION

#### The splitting of the subject and its identification

##### A. Introduction

Given the fact that Lacan's Seminar IX, *Identification* (1961-1962), has not yet been officially published, more than forty years after it was first delivered and over twenty-five years after Lacan's death in 1981, Claude Conté's development in his two papers 'The Splitting of the Subject and its Identification' (1970) and 'Topological Surfaces (1993), are a precious contribution to the understanding of some very complex developments of Lacan in the 1960s and 1970s.<sup>1</sup> Lacan presented for the first time his theory of identification in Seminar IX, then in Seminar XII, *Crucial Problems for Psychoanalysis* (1964-1965), unpublished' and in his later teaching in Seminar XXIV, *L'insu que sait de l'unebévue s'aile à mourre*'(1976-1977). Conté's account is invaluable especially for the logical and topological insights of Lacan's formal developments of the 1960s and early 1970s, and of their relevance for the clinical practice.

In the first paper Conté used the term *clivage* (cleavage, split), in the title, and not *division* or *refente*, which were specific Lacanian terms. Conté wanted thus to underline the link

---

<sup>1</sup> C. Conté methodically took notes of Seminar IX, *Identification* (1961-1962), which together with M. Cholet's typed version, and the handwritten notes of a number of other eminent Lacanian analysts, J. Oury, P. Lemoine, I. Roubleff, J. Laplanche, were used by E. Gabay for the establishment of an authoritative version, which was internally published as a research document of the Lacanian Association *Errata* and which I used for this work.

with Freud's posthumously published work: 'The Splitting of the Ego in the Process of Defence' (1940e [1938]).<sup>2</sup>

Conté's hypothesis was that the Freudian *Ich* should not have been translated as 'ego', as it was not limited to the imaginary ego at the level of narcissism, but extended beyond it. Freud's very early recognition of the function of the object as fundamentally lost had been lost in the post-Freudian interpretation of Freud's metapsychology. Freud's progression from the early conceptualization of the lost object to the formulation of the compulsion to repeat and the second topography, within which he revisited the problem of 'reality', pointed to a wider remit of the 'ego' and to the limits of its symbolization.<sup>3</sup>

In Seminar Book IX, *Identification* (1961-1962), Lacan started with the theme of identity, differentiating it from identification, the difference consisting in that the former was imaginary, the latter symbolic. Identification needed the theory of the signifier as developed by F. de Saussure. It was what Freud's second kind of identification to the 'one trait only' meant, and it was the matrix of identification. Freud's 'one trait only' was what Lacan called 'unary trait', signifier one.

---

<sup>2</sup> Freud, S., (1940e [1938]), op. cit., S.E., **23**, 273 (*Die Ichspaltung im Abwehrvorgang*, G.W., **XVII**, 59).

<sup>3</sup> Conté, C., '*Le clivage du sujet et son identification*', was first published in *Scilicet* 2/3, 103-136, Seuil, Paris, 1970, and was reprinted in *Le réel et le sexuel*, Point Hors Ligne, Paris, 1992, 183-219: '...a totally different dimension manifests itself in the progression from the very early recognition of the function of the object, insofar as it is fundamentally lost, to the formulation of the concept of repetition and the development of the second topography within which the problem of reality was revisited (Conté, C., op. cit., 186). Freud clearly wrote in his 'Three Essays on the Theory of Sexuality (1905d): 'The finding of an object is in fact a re-finding of it.' (Freud, S., op. cit., S.E., **7**, 222).

The second theme was that of the relation between subject and knowledge, and there Lacan introduced the Cartesian cogito in which we can locate the subject of psychoanalysis as the ‘subject supposed to know’. His third theme was the introduction of the metonymical object of desire, and its fundamental role in the process of identification, for the demonstration of which it was necessary to use logic and topology. Freud’s third identification was identification to desire, insofar as desire was the desire of the Other.

In the middle of that development anxiety served as a bridging theme. Anxiety was caused by the Other’s desire, whose object was unknown to the subject.

Towards the end of the Seminar Lacan argued that Freud’s three identifications and the schema in ‘Group Psychology and the Analysis of the Ego’ (1921c), constituted a third Freudian topography, which he later extended to Freud’s developments in ‘Inhibitions Symptoms and Anxiety’ (1926d).<sup>4</sup>

After the second topography, many of Freud’s papers indicated new directions. ‘The Loss of Reality in Neurosis and Psychosis’ (1924b), ‘The Economic Problem of Masochism (1924c), ‘The decline of the Oedipus Complex’, (1924d), ‘Inhibitions, Symptoms, Anxiety’

---

<sup>4</sup> Lacan, J., *Identification* (1961-1962), Seminar IX, 20 June 1962, op. cit., 281. E. Gabay’s and M. Cholet’s versions have *troisième topique* twice, although Gabay’s [*sic*], in brackets, certainly expresses a surprise. Could it be a slip of the tongue? Cholet wonders. But there are reasons as to why Lacan could have argued in favour of a Freudian third topography, which he called the topography of idealizations, and associated it with the second theory of anxiety in ‘Inhibitions, Symptoms, and Anxiety’ (1926d). In Seminar Book VI, *Desire and its Interpretation* (1958-1959), which Lacan called ‘Inhibitions, Symptoms and Anxiety’ (1926d), a ‘topography’ in association with the destinies of the affect. Indeed earlier in his paper ‘*The Unconscious*’ (1915e), when talking about affects Freud inserted in ‘our psychical topography (*Topik*): ‘The affect remains wholly or in part as it is or it is transformed into a qualitatively different quota of affect, above all into *anxiety*; or it is suppressed, i.e., it is prevented from developing at all’ (Freud, S., op.cit., S.E., 14, 178). Freud’s position of the transformation of the affect into anxiety and his second theory of anxiety leads Lacan to say: ‘here we see the beginnings of a position which Freud’s paper “Inhibitions, Symptoms, and Anxiety” will articulate in the topography’ (Lacan, J., Seminar Book VI, op.cit., 26 November 1958).



(1926d), ‘Fetishism’ (1927e), and finally ‘The Splitting of the Ego in the Process of Defence’ (1940e [1938]), and ‘An Outline of Psychoanalysis’ (1940a [1938]) all introduced new structural aspects, such as the second theory of anxiety or the role of the external object in the differentiations of new clinical structures, perversion for example.

Based on Freud’s later work and Lacan’s developments in Seminars Book IX (1961-1962) and Book XII (1964-1965), Conté argued that there was in later Freud a development leading to Lacan’s ‘divided subject’.<sup>5</sup> The concept of ‘the subject’s division’ needed a whole preparatory work related to the perception of a lack ‘in reality’, and what ‘reality’ meant. This was the point where Freud left his work, after the introduction of the superego in the second topography. Lacan started articulating the theme of the subject’s ‘division’ in the early 1960s with the ‘Subversion of the Subject’ (1960) and developed it in Seminars Book IX (1961-1962), X (1962-1963), and XI (1964). In Seminar Book X, *Anxiety*, he introduced ‘four formulas of division’. These formulations were steps towards his later formalizations of the logic of *The Psychoanalytic Act* (1967-1968), in Seminar Book XV or of the Four Discourses in Seminar Book XVII, *Psychoanalysis in Reverse* (1969-1970).

Original subjective division hypothesized by Lacan was the path to the analysand’s ‘subjective destitution’ at the end of the analytic treatment. It occurred at the end of subjective dialectics, although it was always there from the beginning, ‘. . . insofar as we

---

<sup>5</sup> Although in ‘The Ego and the Id’ (1923c) Freud had indicated that *there was a division, a splitting off, a cutting off* of the *id* from the *ego*, he later insisted that that division was not sharp, in order not to weaken the ego (in Lecture XXXI, 1933a) If there was a ‘real split’, he said, the ego would be weak. So, at a later stage he made the ego ‘bound up with the id’. There was only one isolated part, the repressed, which defied the ego’s strength in the form of the symptom. The latter was Freud’s argument in ‘Inhibitions, Symptoms and Anxiety’ (1926d) which paradoxically led some of his pupils to promote the ego’s strength and autonomy, as an aim of the treatment (Freud, S., op. cit., S.E., 20, 97).

have to do with a speaking subject, who can only be constituted in the locus of the big Other.’ But the beginning manifests itself at the end, as Conté paraphrased it: ‘This initial time takes its full function at the end of the subject’s advent, of his realization and this has the greatest relation with that which analytic theory has approached as ‘castration.’<sup>6</sup>

Conté underlined how Freud’s later works brought forward the question of the perception of reality and what meaning the recognition of lack, at the end of the Oedipus complex, took. If the little boy in Freud’s short text *Die Ichspaltung im Abwehrvorgang* (1940e[1938]) is struck, ‘*après coup*,’ by anxiety in the memory of his perception of an older girl’s ‘real’ lack of penis, what was that ‘perception’, and what was that ‘reality’? As Conté asks, how is ‘lack’ registered at that level, if there is no lack registered in ‘the real’ as Lacan had argued? Or, in the first decade of his teaching (1951-1961), Lacan had underlined that only the signifier introduced the notion of lack in the real (for example, the notion that a book can be missing in its place on the library shelves). That was valid until Seminar Book IX, *Identification*. Conté argued that Freud’s *Ichspaltung* (1940c [1938]) first confronted the limits of symbolization. At that late stage Freud asked us ‘to constitute the logic of the absence of a full subject.’ Lacan underlined consequently that Freud, at the end, left us with ‘the gaping hole of a split in the subject’, and Conté added that ‘in that hole the subject hastens to place the phallus.’<sup>7</sup>

Indeed, it was the decline of the Oedipus complex which brought these meta-psychological issues to the fore. As Claude Dorgeuille underlined in his introduction to the debate with

---

<sup>6</sup> Conté, C. (1970), op. cit., 187. Something that the poet T.S Eliot had expressed in ‘East Coker’, the second of his *Four Quartets*: ‘In my beginning is my end.’

<sup>7</sup> Ibid., 186.

Claude Conté on the question of the subject, it was only after the introduction of the superego that Freud had to rethink the structure of the ego.<sup>8</sup>

Conté highlighted the relation of Lacan's 'logic of the lack' -as formulated in table *privation, frustration, castration* (Cf.: This thesis, Chapter 5, p. 299 and **Chapter 6, p.** )- to Freud's topography of three identifications and showed the subject they created as placed on Lacan's three registers.<sup>9</sup> These categories laid out the decomposition and rearrangement of the psychical structure. On the other hand, topology served as the instrument to show how the subject, the object and the signifier as unsubstantial but logical and topological entities could intertwine, cross-check, make a surface, where they meet, separate, associate, and dissociate. As Lacan succinctly put it, 'how the inside meets the outside'. For that reason Lacan used the topological surfaces, and Conté treated them one by one in his last paper.<sup>10</sup> Finally it is important to remember that Freud's topographies were potential

---

<sup>8</sup> Dorgeuille, C. 'La question du sujet', in *Etudes Freudiennes*, no 33, Paris, 1992, pp. 199-213. As we already indicated (cf. this thesis, chapter 3, 181-192 ) Freud accepted a certain number of splits in the ego following the functions of self-observation, criticism and moral conscience becoming more autonomous. The ego which is 'in its very essence a subject' can take itself as an object, can be split, as he wrote: 'I formed the idea that the separation of the observing agency from the rest of the ego might be a regular feature of the ego's structure'. (Freud, S., 1932, Lecture XXXI, 'The structural decomposition of the ego', translated by Strachey as: 'The Dissection of Psychical Personality', in *New Introductory Lectures*, (1933[1932], S.E., 22, 59)

<sup>9</sup> Conté showed this in his paper, 'The Splitting of the Subject and its Identification' (1970) and in his developments in 'Topological' (Surfaces) (1992). Lacan first constructed the table *Privation, Frustration, Castration*, in Seminar *The Object Relations* (1956-1957, Book IV), then took it up again in Seminar *Identification*, (1961-1962, [IX]). It appeared there in session 28 February 1962 in a reduced form. He compared the three forms of 'lack' of the object with Freud's three identifications of the subject in Seminar Book XII, *Crucial Problems of Psychoanalysis* (1964-1965), and used logic and topology to show it.

<sup>10</sup> Conté, C., (1992) 'Topological (Surfaces)', in *L'apport freudien, Eléments pour une Encyclopédie de la Psychanalyse*, Bordas, Paris, 1993. Cf. Lacan, J. (1961-1962), *Identification*, [Seminar IX], 20 June 1961, op. cit., 284: 'This drive which is felt inside the body, those schemata predominantly topological, they put the stress on how to define what functions as coming from inside of the body and what functions as coming from outside...'

topological schemata.<sup>11</sup> Lacan equated topology and the structure in his paper *L'Étourdit* (1973).

## B. The theme of splitting and identification

Conté's first paper (1970) linked together the concepts of splitting (*clivage*) and *identification*. Lacan had also used the terms *refente*, *splitting* and *Spaltung* to signify the effects of identification and later of alienation of the subject to the signifier. In Seminar Book X, *Anxiety* (1962-1963), he wrote the four formulas of *division*. In Seminar Book XII, *Crucial Problems for Psychoanalysis* (1964-1965) he underlined: 'that the being of the subject is split (*refendu*), Freud has repeated it in all sorts of ways, after he discovered that the unconscious could only be translated in knots of language, has, therefore, the being of a subject'.<sup>12</sup> In Seminar Book XVI, *From one Other to the other -D'un Autre à l'autre-* (1968-1969) Lacan used the general topology of sets to formalize in a different way the fields of *Other* and object *a*.

---

<sup>11</sup> As Lacan put it: 'In Freud the relation of the drive to the body is everywhere marked with topology.' (Lacan, J., Seminar Book IX, *Identification*, 20 June 1962).

<sup>12</sup> Lacan, J., 'Crucial Problems for Psychoanalysis', A summary of Seminar XII (1964-1965) by Lacan himself was published in *Autres Ecrits* (2001), p. 199. The last session of this unpublished Seminar, 16 June 1965, was a development on the theme of the subject's *Entzweiung*, a German term meaning division. Division was specified there as partition of the subject between 'knowledge' (*savoir*), 'truth' (*vérité*) meaning (*zwang*), and sex: 'This year we turned around that particular sort of trait which constitutes the subject, the one, that we have been looking for in *Frege*, the formula and status of the subject, insofar as the one appoints itself in the location of lack. This singular one\_\_\_\_, this something which in relation to knowledge is *Zwang* (compulsion), is *zwei* - the two of the sexual being, insofar as it has always been *zwei* - two for the indissoluble one of the imaginary subject, that relation of two (*zwei*) to the *one* of sex . . . this is what we find on all the levels of the relation between the three poles of that trinity . . . this *Entzweiung* is something . . . like the topology of a surface which is such as its right side out comes to join its opposite, its reverse.' (Lacan refers to the surface he drew in the opening of that session.

Using the axiom ‘a signifier represents the subject for another signifier’ which he had introduced in ‘Subversion of the Subject and the Dialectic of Desire’ (1960) Lacan first formalized the subject’s identification to signifier *one*, the one (1) not of unity but of repetition, 1, 1, 1, using Frege’s theory of numbers, in Seminar Book IX, *Identification* (1961-1962). He located the subject’s *aphanisis* in the gap of the ‘binary signifier’ in Seminar Book XI, *The Four Fundamental Concepts of Psychoanalysis* (1964). The subject emerged from two operations, *alienation* and *separation* shown with the intuitive geometry of Euler Circles as used in set theory to show conjunction and disjunction. He argued the subject’s emergence as a signifier in the field of the *Other* as *alienation* and the operation by which the originally lost object *a*, became a remainder and an ornament of the subject itself, as *separation*. The subject’s apparent ignorance, demonstrated in his division by the signifier - ‘he does not know who he is’ - leaves the question unanswered as to ‘what he wants’, the question of the object of desire, and the subject constructs his *fantasy* around that second unknown. (The Latin *se-parare* means both separation and being adorned with).

- The first schema of division <sup>13</sup>

A	S
\$	A barred
<i>a</i>	

---

<sup>13</sup> Lacan, J., *Anxiety* (1962-1963), Book X, Paris 2004, p.37: ‘In relation to the Other, the subject who depends on that Other, inscribes himself as a quotient. He is marked by the unary trait of the signifier in the field of the Other. However, he does not cut the Other into slices. There is a remainder, a residue in the sense of a division. This remainder, this final Other, this irrational, this proof and only guarantee of the Otherness of the Other, is *a* . . . They are both [\$ and *a*] on the side of the Other, because fantasy, the support of my desire is on the side of the Other in its totality . . . What is now on my side is that which constitutes me as unconscious, A barred . . .’

In the first line on the left we find the big Other,  $A$ , the locus of the signifier, and on the right the subject  $S$ , the subject as not yet appearing. In order to become, the subject emerges in the field of the Other as divided,  $\$$ , marked by the originally repressed signifier.  $A$  becomes barred as a result, but ‘is not sliced open’, as Lacan says. The operation leaves a remainder and this is object  $a$ , the Otherness of the Other. But on the side of the subject there is nothing.

- The second schema of division

$A$        $S$

$\$ A$       barred

$a$   $0$

Lacan, J., *Anxiety* (1962-1963), Seminar Book X, op. cit., 135

In the repetition of the operation of division between  $\$$  and  $A$  barred, object  $a$  is the remainder, and the subject is marked as  $0$ .

- The third schema of division

$A$   $S$

$a$        $A$  barred

$\$$

In the third round of division, the subject asks the Other ‘how many times?’ Supposing the operation is done again between  $a$  and  $A$  barred, the subject is divided again,  $\$$ , ‘ $a$  is what remains as irreducible in the total operation of the advent of the subject in the place of the Other and it is from there that he takes his function’. (Lacan, J., op. cit., 189)

$$\begin{array}{c}
 a \\
 \$ = \text{-----} \\
 S
 \end{array}$$

The fundamental question for Lacan examining the Cartesian cogito was the question of the Real before the coming to being of any subject and how the entry of the signifier in the Real affected the becoming of the subject. His topological figures in Seminar IX *Identification* (1961-1962) and in Seminar XII, *Crucial Problems of Psychoanalysis* (1964-1965) address this question. For example, he chose the topological surface called ‘Klein bottle’ because it can show the trajectory of the subject via the signifier 2 -> 1, meeting his reverse in object  $a$ . We can see that in:

Conté’s figure of the Klein bottle (Cf.: This thesis, Chapter 6, p. 322)

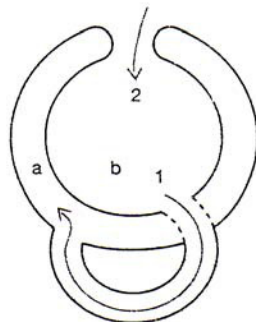

As Granon-Lafont put it the Klein bottle is a closed surface in which the internal space and the external are homogenized: 'It is a sphere, on which a tunnel becomes the handle, it is a bottle whose bottom joins up with the neck operating a cross-check in the form of a circle.'

14

Klein bottle as shown by Granon-Lafont

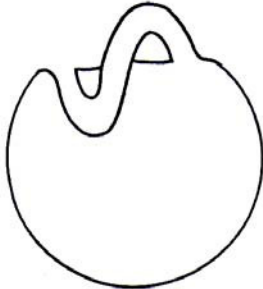

We can apply Aristotle's syllogism on the Klein bottle:

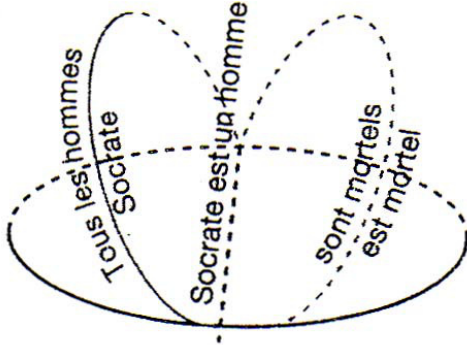

The trajectory of the subject within the Klein bottle goes from identification to the signifier –all men are mortal, Socrates is a man, Socrates is mortal- to des-identification, the

<sup>14</sup> Granon-Lafont, J. *La Topologie Ordinaire de Jacques Lacan*, 1985, 103.



foundation of what can be revealed to be operative in the treatment, and specifically in interpretation, but also shows its limit, object *a*:<sup>15</sup>

*I* and *a*, ‘unary trait’ (*I*), the signifier supporting the subject’s identification and object *a*, cause of desire, had been designated as the two poles to be kept separate in the treatment in Seminar Book VIII on *Transference* (1960-1961). Conté further explained that the analytic concept of identification raised certain problems:

‘If the subject can only be identified to a signifier –and this is the foundation of that which operates in the treatment and specifically in interpretation- from that moment identification becomes inseparable from subjective splitting (*refente*) and gives it its limit, because the division, in which the subject is constituted, cannot be the last term’.<sup>16</sup>

There is a remainder, object *a*, part object, object cause of desire, which concealed in the Other was what the subject was after, and oriented his identificatory movement at the same time as giving it its stopping point. *Ego ideal* and object *a* must be kept separate. ‘The coming into play of ego-ideal’, as Conté underlined, ‘is not enough to account for the end of the analytic treatment...one must maintain the third term which is object *a*’. But also: ‘the concept of *splitting* has to be articulated to *object a*, to its opaque presence in the desire of the Other, which is the desire of the analyst.’<sup>17</sup> Thus, the clinical consequences of the operation of division or splitting are demonstrated:

---

<sup>15</sup> Conté, C., ‘Topologiques (Surfaces)’ (1992), in op. cit. 442.

<sup>16</sup> Conté, C., ‘The Splitting of the Subject and his Identification’, 1992 [1970], *The Real and the Sexual*, 185.

<sup>17</sup> Conté, C., *ibid.* In French *fin* means both: end and aim. In his numerous papers on the ‘pass’ Conté emphasized the role of the analyst as *object a*. As such he supports the desire of the analysand, becomes something which Lacan called in his ‘October 9, 1967 Proposition’: ‘the unknown which orders itself as the frame of knowledge’. He becomes at the end of the treatment a residue, a left-over and is discarded. This is

The concept of division of the subject cannot come into play before a long preparatory work, insofar as splitting (*refente*) can only take its true function at the end of the subjective dialectic and cannot be grasped or thought before. This is for us the end of analysis in the two meanings of the word'.<sup>18</sup>

The concept of splitting can also support the evidence of the structural differences between neurosis, perversion and psychosis.<sup>19</sup>

Identification to the signifier causes the first splitting, and the last splitting is caused by identification to object *a*. This is why the theme of *identification* came late in Lacan's teaching; it needed a certain preparatory work. Freud also could only develop the concept of *splitting* of the subject after he developed the second topography, in which the *id* or unconscious ego was introduced. Lacan could only give a proper status to object *a* after developing the topology of the signifier which represents the subject for another signifier so that the real is marked as the space where object *a* appears.

---

what Lacan meant with 'the analyst's disbeing' (*desêtre*). In Conté, C.: 'Pass and Practice of Psychoanalysis', op. cit., 260.

<sup>18</sup> Conté, C., op. cit., 187

<sup>19</sup> Cf. 'Anxiety and identification' was the title of Pierra Aulagnier's presentation on 2 May 1962, in Lacan's Seminar *Identification* (1961-1962, Book IX). Given in the aftermath of the *Journées Provinciales* on 'anxiety', organized by the SFP in March 1962, it responded to Lacan's formulation that anxiety was anxiety of the desire of the Other, given in the previous session. Aulagnier added that anxiety proper submerges the subject. He becomes the affect of anxiety, as happens in psychosis. She argued against the often held view that the psychotic subject cannot recognize his anxiety. What characterizes anxiety, she said, is that it cannot name itself, it can only be recognized by the Other. So anxiety has a particular relation with speech, insofar as it cannot be spoken. Another example of an unspoken extreme experience was orgasm. She suggested that Lacan found it difficult to place anxiety as a signal on the level of the ego/subject, and that anxiety had its source in the Other: 'It first emerges in the Other and it is the affect to which usually the subject responds with a mirroring reaction, either flight or anxiety.' Thus anxiety resembles a black hole where identification momentarily collapses, a space like the internal hole of the torus: '*Jouissance* and anxiety are the two extreme positions where the ego [the subject] can be situated. In the former the subject and the Other for a moment exchange their insignia, recognize each other as two signifiers of shared *jouissance*, which ensures for an instant the identity of desire. In anxiety the ego [subject] and the Other, they both dissolve, are nullified in a situation where desire fades, as it cannot be named.' (Lacan, J., *Identification*, op. cit., 204). Lacan formalized the structure of fantasy 'by essentially linking the moment of a *fading*, the eclipse of the subject . . . closely tied to the *Spaltung* . . . to the condition of an object . . .' (*Ecrits*, 2006, op. cit., 691). He now strongly emphasizes that the subject is excluded by the signifier in the experience of anxiety.

### C. The subject supposed to know.

An important aspect in the relation of the subject to the signifier was the question of knowledge bringing in the concept of the 'subject supposed to know' which Lacan started developing in Seminar Book IX, *Identification* (1961-1962), and further explored in Seminar Book XIII, *The Object of Psychoanalysis* (1965-1966). Knowledge and truth became the two poles of the subject's division, comparable to *thinking* and *being* the two poles of Descartes' *cogito*. Lacan located the modern subject there, in the splitting between 'science' and 'truth'.

'Knowledge' (*savoir*) and the modern subject's relation to it, especially of the subject of psychoanalysis was the reason why Lacan turned to Descartes' *cogito* in the first place. Conté started his paper 'The Splitting of the Subject and his Identification' (1970) with the question of knowledge in the modern world and the notion of the 'subject supposed to know,' which Lacan introduced in the Seminar *Identification*. It is the term which supports transference, 'whether it is supported by the analyst himself, or not.'<sup>20</sup> The subject was a supposition, was literally lying under the chain of signifiers; it was a supposed subject of supposed knowledge. If the subject in Descartes' *cogito* interested Lacan, it was as the opposite of Hegel's subject of absolute knowledge and its various forms of idealization. But, modern science involved the 'foreclosure of the being of the subject' and scientific knowledge was the suture (*suture*) of its lack, while in psychoanalysis the subject was 'non-

---

<sup>20</sup> Conté, C., op. cit., 188. Lacan made it the operator of transference in 1967.

saturated' (*non-saturé*), but 'calculable'.<sup>21</sup> This is why in 'Science and Truth' Lacan rejected the term 'human sciences':

'There is no such thing as a science of man, and this should be understood along the lines of "there is no such thing as insignificant savings". There is no such thing as a science of man because science's man does not exist, only its subject does'.<sup>22</sup>

He replaced it with the term 'conjectural sciences' , to oppose it to the 'exact sciences' . With the former he meant formal sciences such as game theory, the signifying combinative, linguistics, and logic and then introduced his own science for psychoanalysis, 'linguisterie' and 'elastic logic'. He underlined that some conjectural sciences such as modern logic had tried to 'suture' (*suturer*) the subject, but had failed, as Gödel's theorem showed. It was on the 'sutured' subject of science that psychoanalysis operated.<sup>23</sup> The unary trait, the ideal primary identification will function in psychoanalysis up to a point as the suture of lack, ego-ideal. But, as the progress of psychoanalytic science showed, the signifier which would make the subject *one* is missing.

We followed the developments on the theme of knowledge, science and truth as it emerged in Lacan's Seminar IX, continued in Seminars XII and XIII, and was taken up again by Conté here. Conté underlined that Lacan was interested in Descartes' *cogito* because it

---

<sup>21</sup> This was the thrust of Lacan's argument in 'Science and Truth' (*La science et la vérité*), the opening session of his seminar *The Object of Psychoanalysis*, Seminar Book XIII, 1965-1966, published separately in *Cahiers pour l'Analyse*, No 1 and 2, 1966. Also in *Ecrits*(2006[1966]) 726.

<sup>22</sup> Lacan, J., *Ecrits*, op. cit.: 730; Lacan's own short account of the previous year's Seminar Book XII, 1964-1965, was published in *Autres Ecrits*, Paris, Seuil 2001: 'That the being of the subject is split (*refendu*), Freud did not stop repeating it . . . since he discovered that the unconscious was translated in knots of language, and therefore had the being of a subject.' Signaling that the *cogito* was not the foundation of consciousness but of the subject's splitting, that one between thinking and being, Lacan underlined that in the enunciation *I am thinking; therefore I am* the subject showed the torsion he 'has undergone in its knotting' and we have to make the topology of that torsion (op. cit., 199).

<sup>23</sup> But the opposition between exact and conjectural sciences is lessened as the conjecture is susceptible of 'an exact calculation'. Cross-refer this thesis, Chapter 6, p. 326.

foreclosed the being of total or absolute knowledge. Descartes renounced empirical knowledge and suspended all his investigations into the sole guarantee of a non-deceiving God; he entrusted truth to something which was internal to the structure, put the signifier in the very place of the Other. The Klein bottle is the topological surface which best can show this (Cf.: This thesis, this Chapter 6, p. 322)

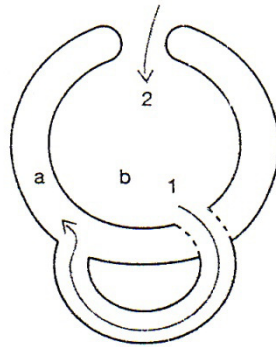

‘Following trajectory 1, the subject finds itself in *a* on the other side of the lining, in the “between the two”. Point *a* symbolizes the *other scene* of Freud, *a* is the truth of the dream, at this point *Heimlich* is *Unheimlich*.’<sup>24</sup>

As Conté noted, here the macrocosm reveals itself to be in continuity with the microcosm, a surface where the subject can come without crossing any edge to a point which is the reverse of its décor. ‘The subject can only grasp himself inside the structure, but we have to account for what the experience demonstrates to us by taking its foundation there: the structure is such that the subject can come to know how he finds his lodgings within it’.<sup>25</sup>

<sup>24</sup> Conté, C., 1991[1970]), ‘The Splitting of the Subject and its Identification’, op. cit., 184.

<sup>25</sup> Ibid.

In his Seminar Book XIII, *The Object of Psychoanalysis* (1965-1966, unpublished), Lacan raised the question whether psychoanalysis itself was a science, a science whose object was ‘*object a*,’ inserted in the subject’s division as the result of a reduction.

## Topological Surfaces

### A. Introduction

This chapter becomes the core of this thesis’ claims, as it deals with Lacan’s topological surfaces presented in Seminars Book IX, *Identification* (1961-1962) and Book XII, *Crucial Problems of Psychoanalysis* (1964-1965), with the gloss added to them by Claude Conté. The importance of *topology* and the predominance of the *real*, starting from Lacan’s developments in the 1960s, are the core of the final part of this thesis. Topology, a branch of modern mathematics, became as crucial for the formalization and transmission of psychoanalysis as linguistics or logic were in Lacan’s earlier teaching. The discourse of modern Mathematics is crucial for the transmission of psychoanalytic theory and clinical practice. Lacan underlined that topology was neither a metaphor nor an illustration, but the structure itself in one of his papers from the last period of his teaching, namely *L’Étourdit* (1973). The word is an amalgam of the adjective *étourdi* meaning ‘scatterbrained’, ‘thoughtless’ or ‘dazed’ - and the participle *dit* to convey precisely the idea of the unsaid, a

saying behind what is said. From the beginning of the 1960s Lacan linked the discourse of mathematics, with the discourse of psychoanalysis.

‘Isn’t it (*n’est-ce pas?*) that topology is the space (*n’espace*) to which leads us the discourse of Mathematics and which demands a revision of Kant’s [transcendental] Aesthetics? No other ‘stuff’ to give it than the language of the pure *matheme*.’<sup>26</sup>

Among the *mathemes* of Lacan for the transmission of psychoanalytic theory and clinical practice figured the topological surfaces, distinct topological objects which are built and are in themselves peculiar spaces, such as cuts, and holes, the Moebius strip, the torus, the cross-cap, the Klein bottle, to name the main ones. Some can be constructed physically, for example the Moebius strip, or the torus, others are impossible to be built in Euclidian three dimensional space, but can be figured geometrical, laid down on a flat surface (*mise à plat*) and show cuts, trajectories and passages over and under, for example the cross-cap or the Klein bottle. Cuts are surfaces themselves, such as the ‘internal eight’ or double-loop surface, which is the same as the edge of the Moebius strip.

Another cut is called ‘a-sphere’: The ‘a-sphere’ is a half-sphere, an off-cut of the cross-cap, which ‘projects itself on the other heterogeneous component of the cross-cap’, the Moebius strip. Or to put it the other way: ‘It is the round slice which closes the Moebius strip, and forms the cross-cap’. Lacan showed this closed cut as ‘the said’ (*le dit*). It ‘makes subject (*fait sujet*), whatever it surrounds’. Thus topology was the ‘*dit-mension*’ of an impossible

---

<sup>26</sup> Lacan, J., ‘L’Etourdit’, *Scilicet 4*, 1973, Seuil, Paris. The paper was written in 1972. Lacan defined psychoanalytic topology as the place of ‘saying’, which in the discourse of mathematics is the real surrounding the impossible to say. ‘That one says (*qu’on dise*) remains forgotten (*reste oublié*) behind what is being said (*derrière ce qui se dit*) in what is being heard (*dans ce qui s’entend*)’. The term ‘matheme’ was a neologism of Lacan (made from ‘mathematics’ and ‘*mathema*’, which, in Greek, means ‘lesson’). Mathemes were algorithms of transmission, as Lacan underlined the need to go beyond Kant’s intuitive space of Transcendental Aesthetics (*Ecrits*, 2006: 478 and Miller, J.A. ‘Commentary on the Graphs’, Op. cit., 903).

and the impossible was the very definition of the real, the third register of human experience.<sup>27</sup> It was taken within the structure but without it being possible to exist or be represented or said: ‘The structure is the real which comes to light in language . . . Topology is not a substance to postulate as beyond the real. . . it is not theory . . . it is not made to guide us in the structure, *it is that structure.*’<sup>28</sup>

In the impossible to show space of the real was supposed to nest object *a*. This non-specular object was concealed in the structure of the hole or to support the cut, impossible to grasp, perhaps possible only to have a glimpse at. The evening before session 24 January 1962 of Seminar IX, *Identification* (1961-1962) Lacan gave a talk on Freud’s ‘Theme of the Three Caskets’ (1913f), a story Freud found in Shakespeare’s *Merchant of Venice*. Lacan found there object *a* and its role in identification.<sup>29</sup>

---

<sup>27</sup> The three registers of the human experience were formally introduced by Lacan shortly before the Congress of Rome in which he gave his famous address known as ‘The Rome Discourse’. Lacan’s lecture of 8 July 1953 ‘The symbolic, the imaginary and the real’ was published in the ‘Acts of the Congress of Rome’. He gave a first formalization of the three registers using a combinative of small letters *s, i, r*. But ‘the real’ as ‘the real of the subject’ was shown in the surfaces of cuts and holes, where object *a* could be glimpsed. It was ‘revealed to us as a field of our experience, of the Freudian experience or should we say, experiment,’ and as such it was the last to appear (Lacan, J., Seminar IX, *Identification*, 13 December 1961).

<sup>28</sup> Ibid. It is perhaps important to note here that J. L. Austin’s Cambridge Lectures *How to do things with words* were published in English in 1962, year of the *Identification* Seminar. Before and after their translation in French (*Quand dire c’est faire*, 1970), Austin’s lectures on the pragmatics of language had an impact on French linguistics, and lacanian psychoanalysis alike.

<sup>29</sup> Freud, S., (1913f), S.E., **12**, 289. In lecture ‘*De ce que j’enseigne*’ (23 January 1962), Lacan interpreted the story using elements from Freud’s metapsychology and his own theory of object *a*. He used topology to remind his audience that Freud’s  $\psi$  system was a bilateral surface, the good side being the one which defends itself from the outside and the other side, directed to the inside, which is less defended. In that sense it was a Moebius strip. Freud had presented the body as surface or rather the projection of a surface (in his second topography, *The Ego and the Id*, 1923b). Lacan suggested that the body was that topological surface of a Moebius strip on which the signifiers were inscribed (as in Freud’s theory of the double inscription). Enjoyment (*jouissance*) can happen there too through the intermediary of narcissism *i(a)* an identification which involves object *a*. Thus, enjoyment of the body was felt like a deadly menace.



### The Moebius strip belt

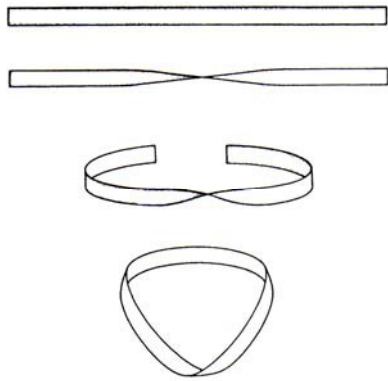

Lacan, J., (1962-1963) Seminar Book X, *Anxiety*, 9 January 1963, 114.

Despite its appearance this surface has one side only. An ant travelling on the surface can pass from one side of the band to the other without crossing a border.

### B. Conté's account of Lacan's topological surfaces

With all this in mind we present now the topological surfaces of Lacan, which Conté accompanied with his gloss and clinical vignettes. We are also helped at the same time by the accounts of Lacanian topology by other contributors.<sup>30</sup>

The origins of topology are to be found in Leibnitz's definition of *analysis situ* (1679), a new branch of mathematics. It really started, however, with Euler's theorem (1750) which

---

<sup>30</sup> Granon-Lafont J., *La topologie ordinaire de Jacques Lacan*, Point Hors Ligne, Paris 1985, Vappereau, J.M., Etoffe, 1988, Darmon, M., *Essai sur la Topologie Lacanienne*, Association Freudienne, Paris, 1990, Dor, Joel, *Introduction à l'enseignement de Jacques Lacan*, Volume II, Espace Analytique, Paris 1992.

provided new solutions to the problems of Euclidian geometry. Moebius took over from him with the definition of the unilateral polyhedrons one of which was the strip that took his name (1861). With the unilateral surfaces topology took over. It was the space of projective geometry (Felix Klein, 1874). In 1948 'Bourbaki'<sup>31</sup> was formed which reformulated all mathematical discoveries in terms of structure and defined three or rather two of those structures to which a third was added: the structure of order, the structure of group, and the topological structures. Lacan uses the topology called 'algebraic topology' which can use geometric figures not built in a Euclidian space and not general topology which uses set theory.

Conté emphasized the clinical aspect of the topological surfaces. The *single torus* showed the structure of the subject in the dialectics of demand and desire. The *intertwined toruses* showed the complexities of the relation to the Other's demand and desire, defining the different forms of neurosis. Euler circles with a 'de Morgan intersection' showed how the subject, in those dialectics, proposed the phallus in place of the object cause of desire of the Other. The *cross-cap* was another topological surface whose structure could support the trajectory of phantasy, and on which a certain cut called 'internal eight' could open up the structure to just have a glimpse, perhaps, to the object of fantasy, the object cause of desire. The process of going from identification of the subject to the signifiers of demand to de-identification was supported topologically by the *Klein bottle*, within which the subject's trajectory helped by transference and interpretation in the treatment, could bring him, on

---

<sup>31</sup> Bourbaki was the name adopted by a group of top mathematicians working in Nancy and Chicago Universities who became the centre of modern mathematical developments from 1940-1980. There are at least 600 publications under that name. The other two areas of Mathematics are algebra and order relations.

the other side of the lining of the surface, make a cross-check (*recouplement*) and find himself ‘on the other side of the décor’. As Conté reminded us, Lacan wanted to construct a new *aesthetics* which was not Kant’s *transcendental aesthetics*, based on the geometry of a sphere into a sphere, the starry heaven and the moral law inside it, but the *logic of lack*.

Human experience could all be inscribed on a surface of maximum two dimensions, Lacan had argued. This was what Freud was indicating already with  $\psi$  system in the ‘Project’, or with the successive inscriptions of signs in ‘Letter 52’ to Fliess (December 6 1896), and the double inscription of his paper ‘The Unconscious’ (1915e). They all implied a flat surface like a piece of paper. But it is not certain that space has three dimensions. Only two dimensions are certain for the human subject. <sup>31</sup> We are therefore going to consider a different sort of space not the ordinary three dimensional, Euclidian spaces, but space built by the number of revolutions of a surface or by cuts and stitches. Time, the time needed to make these operations counts as the third dimension.

Topology uses up to four dimensions. It uses manipulations and transformations in continuity, which does not disturb the topological properties of a surface. Plying, folding, applying one surface on another are used in topology. In his research on the ‘Intrinsic Topological Surfaces’, *Etoffe* (1988), J.M. Vappereau transformed by vectorialization Freud’s diagram in ‘Letter 52’ which he calls *Schema F*, to Lacan’s *Schema R* which is a

---

<sup>31</sup> Conté, C., J., (1993) *Topologiques (surfaces)*, op. cit., 432. In *La Topologie Ordinaire de Jacques Lacan*, J. Granon-Lafont (1985) showed the transformation of space that the successive revolutions of a spoon attached to a ribbon produce. The Moebius strip is such a space. A hypothetical ant walking on it can find itself on the other side of the surface and come back without having crossed the edge. The Moebius strip is such a ribbon with one half-twist.

projective plane. Schema *R* was presented in ‘On a Question Prior to any Possible Treatment of Psychosis’ (*Ecrits*, 2006: 462). He juxtaposed Schema *L*

Vappereau’s ‘graph *F*’ (for *Freud*) on schema *R* of Lacan.

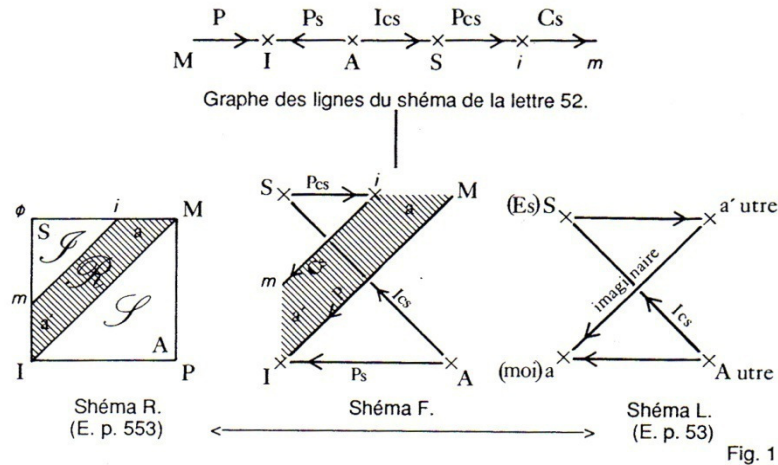

Vappereau, J.M., ‘Etoffe’, *Les surfaces topologiques intrinsèques*, 18.

- P, Ps, Ics, Pcs, Cs: Initials in French for Perception, Perception Signs, Unconscious, Preconscious, Consciousness (cf. this thesis, chapter 1, p. 68)
- The Projective Plane, M, I, A, S, i, m: for Mother, Ideal, Other (Autre), Subject, little other i (*a'*), ego (m).

Other transformations creating new surfaces take place through cuts or sewing sides. Some surfaces can keep their topological properties after a cut; others are destroyed or become new ones. ‘Surfaces’ are topological objects of one, two, three or even four *dimensions*. Lacan thought we could go up to five dimensions perhaps. We have unilateral surfaces (with one side only) such as the Moebius strip with one half-twist, or bilateral surfaces such

as the torus and the cross-cap. Cuts can be themselves surfaces, for example the double loop called ‘internal eight’ cut. Topological surfaces can be *closed* (no edge) such as the sphere or the cross-cap, and the Klein bottle, and *open* (with one edge) like the Moebius strip. The double loop or internal eight cut(s) on a cross-cap can open it, but not slice it completely. There is a closed cut remaining (the non-said), and a small round disc which falls off as a result of the cut. It shows object *a*.

Moebius strip figure 1. An ordinary strip when half-twisted traces a figure of internal eight or double loop:

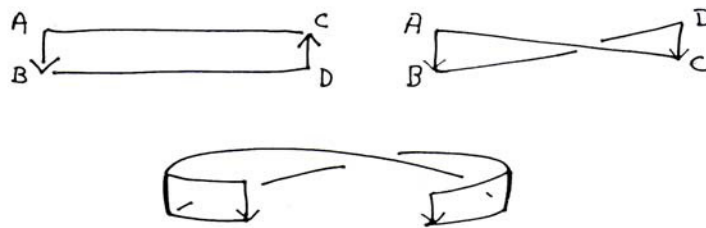

Granon-Lafont, J., 1985, op. cit., p.30

‘Line AC of the original strip continues in BD. There is now only one edge. It traces a figure which resembles an eight folding on itself. Lacan called it “internal eight”. This line can also be described as a loop closing on itself. Lacan gave it also the name “double loop” (Granon-Lafont, J., ibid.).

Moebius strip figure 2

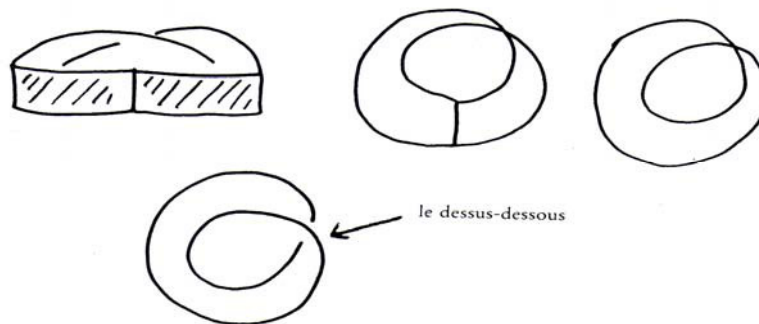

Granon-Lafont, J., 1985, op. cit., p.31

In order to see the double loop properly, from Moebius strip fig. 1, which is an object still represented in ordinary three-dimensional space with an illusion of depth, we have to pass to Moebius strip fig. 2, a two dimensional representation, ‘a laying flat’ (*mise à plat*), as the topologists do. ‘The cross-check and the discontinuous line do not evoke depth, but a going over and under.’ (Granon-Lafont, J., *Ibid*)

Lacan developed the Moebius strip in Seminar Book XIII, *The Object of Psychoanalysis* (1965-1966).

In Seminar Book IX, *Identification* (1961-1962), Lacan presented the torus as the topological transformation of a sphere from which a handle was extracted. He placed on that handle the graph of desire (Cf.: This thesis, Chapter 6, p. 346). A torus can be built in three dimensional space; it looks like a doughnut. Topologically it is a two-sided surface without an edge. It has an inside and an outside. (Cf.: This thesis, Chapter 6, 346). It can be built by the rotation of a double circle, to which we give a volume, around a central axis

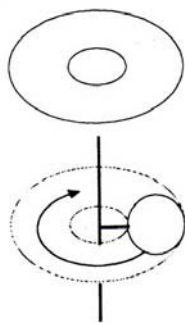

Lacan, J., Seminar IX *Identification*, 7 March 1962, op. cit., 131.

The two holes of the torus, the internal void and the central void are irreducible. The internal void is known as 'soul' (*âme*) of the torus. On it Lacan showed the process of demand of the subject as circles traced around the internal void surrounding object *a*. A second circle around the central void is traced at the same time by the subject who does not know it. The internal void accounts for object *a*, the central void for the subject as unconscious,  $\beta$ . It is the logic of *privation*, the subject's first identification to the Father, where he is -1, nothing, and even when the two trajectories combine in trajectory  $\gamma$ , they do not catch any object.

The three single toruses and their trajectories  $\alpha$   $\beta$   $\gamma$

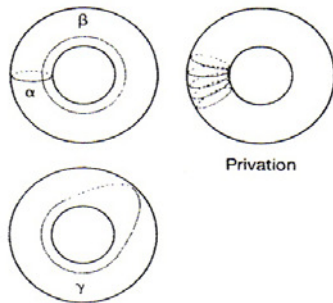

(Conté, C., op. cit., 1993, 434)

As Conté underlines, the subject's trajectory in the single torus is twofold. In the figure above trajectory  $\alpha$  surrounds the internal void with the repetition of demand always missing what it encircles, object *a*. At the same time another trajectory  $\beta$  traces another circle around the central void, of which the original subject knows nothing; 'he knows nothing of his dependence on the signifier'. Circle  $\beta$  is constitutive of the unconscious. The combined trajectory of  $\alpha + \beta$  form trajectory  $\gamma$ , surround two voids. This operation has been called by Lacan *privation* and by Conté first identification to the Father of the subject's prehistory.

Lacan likened it to Kant's *ens privativum*, 'a being empty of the concept' or the empty pot of mustard (Cf.: Kant's table of 'Nothing', this thesis, Chapter 5, p. 302)

We can take two toruses and built one into the other. It is another topological operation called intertwined toruses. They show the operation of *frustration* :

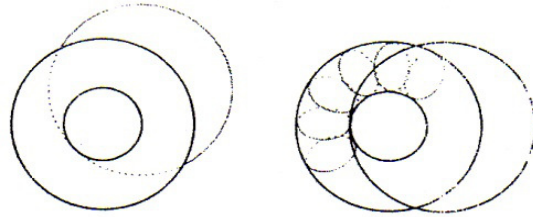

Conté, C., (1993), 434.

These intertwined figures show the subject and the Other. In the trajectory of demand around the object of desire, the subject ends up surrounding the central void of the second torus. There is an illusion that the two holes interlock. He ends up believing that the object of desire is ravished by the Other.

This is shown clearer in the figures below:

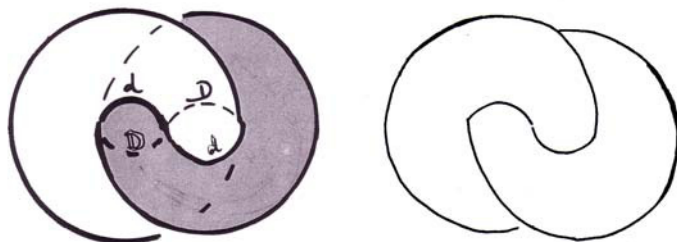

Granon-Lafont, J., 1985, 56 and 146.



As Granon-Lafont put it the figures above show a knotting where the demand of the one is the desire of the other and vice-versa: ‘The image of two intertwined toruses is the metaphor of the hole. It brings a consistency which supports the contradiction of not-having: the hole has a consistency which cannot be imagined. The edge of the hole is the representation of the hole itself.’<sup>32</sup>

Conte showed also the following two single and one intertwined toruses figures:

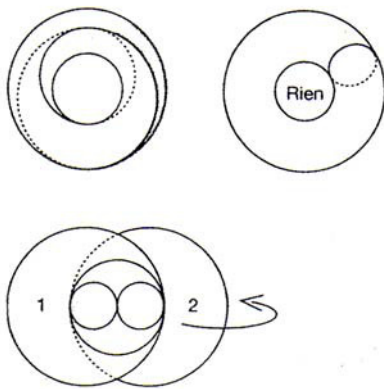

Conte, C., 1993, op. cit., p. 439

In the single torus on the right, demand repeated around the internal void surrounds nothing (*rien*), when in the single torus on the left, when the second circle around the central void is complete, demand has gone around the contour of the object without knowing it. It has also encircled the central void of the second torus (2, the Other), in the intertwined figures at the bottom. The two voids interlock as torus 2 pivots around torus 1.

---

<sup>32</sup> Granon-Lafont, J., op. cit., 146

‘By repeating itself on torus 1 as a series of trajectories  $a$ , the subject’s demand surrounds the central void  $\beta$  of torus 2, which figures desire. The object is here presented as ravished, held by the other of rivalry; demanding the object of his desire on which there is no possible answer, the subject ends up in making the object of the Other’s desire inaccessible.’ (Conté, C., Ibid.)

It is the situation common in neurosis. The demand of the subject and the desire of the Other have no common measure, but the desire of the subject includes necessarily the demand  $x$  of the Other, and this causes anxiety. Anxiety is overcome by the subject proposing the phallus as the object of the Other’s desire.

The mediation by the phallus

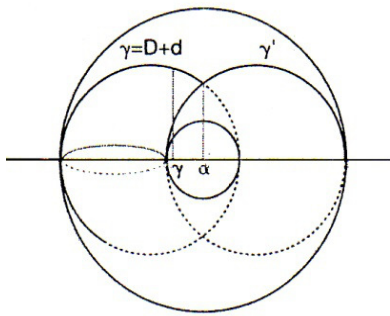

Conté, C., (1993), *Topologiques (Surfaces)*, 435.

As Conté put it, ‘I don’t know the Other’s desire, but I know its instrument, the phallus’ (Ibid.). The phallus, as the mediator is figured above in the diameter of trajectory  $\gamma$  whose perpendicular falls within the empty circle of the subject. Object  $a$  has also its perpendicular falling on the same empty circle (the subject), but at a distance and in a different way for the subject.

But, the solution by the phallus, the neurotic solution concerning desire is an ‘imperfect solution’ as the anxiety of losing the phallus (*aphanisis*) remains. Another way is to go beyond the point of castration towards object *a*.

*Castration* was one of the three modalities of lack that Lacan had shown in his logical table *privation, frustration, castration*. Conté underlined the parallel between Freud’s three identifications and Lacan’s three modalities of lack. The table Lacan produced in Seminar Book IX was a reduction of his table in Seminar Book IV, *The Object Relations*, 1956-1957(Cf.: This thesis, Chapter 5, p. 299)

Agent		Subject	Object
Castration R S I			
Frustration S I			R
Privation I R S			

Lacan, J., *Identification*, Seminar IX, 28 February 1962, 124

Conté placed on the horizontal line the *Agent* as *A*, the *Subject*, and the *Object* and on the vertical line and produced a slightly different table:

	L'agent est l'A comme A	Le Sujet est affecté au niveau Sujet	l'objet est
Castration	(R ?)	S	I
Frustration	A (ou S)	I	R
Privation	I	R	S

Conté, C., 1993, op. cit, 443

Conté thus underlined the three kinds of subject as a result of each operation at the symbolic, the imaginary and the real register. *Privation* was the foundation of lack. It was the first operation of identification to the father 'in the form of a devouring oral drive', before any object choice and before any subjectivity. 'It affects the Other's being and refers us to the absent essence of the body' (ibid.). It was ego ideal. This identification is met clinically in psychosis.

*Frustration* concerned the dialectics of demand and desire. It was Freud's second identification, that to the 'one only trait' chosen from the abandoned love object. Lacan called it 'unary trait', and said first that it was the signifier, any signifier. It concerned the Oedipus complex and identification to the subject's ideals. It was a regression from love. It is met clinically in neurosis, but also in melancholia.

*Castration* was the third form of identification. It concerned the Other's desire and involved the dialectics of having or being. But, as Lacan had remarked, the subject's libido is not spent totally in the Other's dimension. There is a remainder, object *a*. As Conté underlined,

neither being nor having can fulfill the subject's desire. 'Castration' is a process of 'de-subjectification', of identification to the trait of object *a*, and that trait, as we are going to see, is more than a signifier, it involves the real; it is met at the end of analysis but it was there from the beginning.

Lack is first the lack in the subject. In formulating his logic of lack Lacan found his support in Charles Peirce's logic of propositions as Peirce showed them in his *Quadrant* (Cf.: this thesis, Chapter 5, 305-306). Lacan used it and placed the subject in the empty case of as -1. As Conté reformulates: 'in the quadrant of Peirce the subject occupies the empty case, and the universal affirmative is founded on the union of case 1, 'all traits are vertical', and case 4, which is empty: 'no trait'.<sup>33</sup>

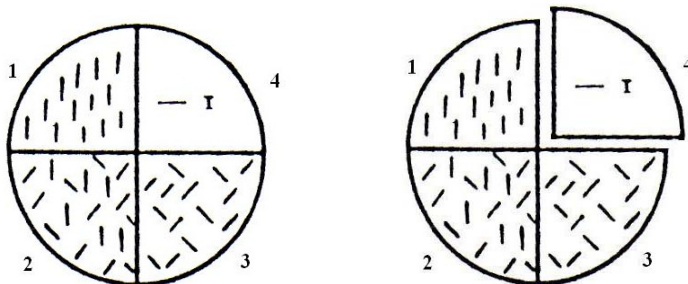

<sup>33</sup> Conté, C., (1992 [1970]), 194 and (1993) 'Topologiques (Surfaces)', 433; Lacan, J., Seminar Book IX, *Identification*, 17 January 1962, 91-92; and Peirce's Quadrant, Appendix V, op. cit., 345) The quadrant of Peirce is based on a modification of the premises of the Aristotelian Logic of propositions formalized in medieval times as Aristotle's square. The American philosopher took a critical view of the use of *quantity* as the criterion for the distinction between Aristotle's *Universal* and *Particular* Propositions (UP) and of *quality* as the criterion for the distinction between *Affirmative* and *Negative* propositions (AN). Universal Affirmative (A) and Universal Negative (O) propositions implied, for reasons of consistency, the existence of the subject, whether it existed or not. But, Peirce chose a different criterion and turned round in a clockwise direction Aristotle's propositions according to the distinction between  $\Lambda\acute{\epsilon}\xi\iota\varsigma$  and  $\Phi\acute{\alpha}\sigma\iota\varsigma$ . Universals and Particulars involved the subject, therefore its existence could be asserted or denied ( $\Phi\acute{\alpha}\sigma\iota\varsigma$ ). Universals do not imply the existence of the subject, while Particulars do. For the Affirmative and Negative Propositions the distinction will apply on the predicate only ( $\Lambda\acute{\epsilon}\xi\iota\varsigma$ ). Extracts in Appendix V are from: Peirce, C., *Collected Papers*, Cambridge, Harvard University Press, 1960, Vol. II, Book III, Chapters 1, 2 and 3. Cf.: This thesis, Chapter 5, p. 306-307.

The propositions were placed by Peirce on the Quadrant according to his own conception of classification. On the left hand side, the Universal Affirmative, **A**, and the Particular Affirmative, **I**, encompassed by the term  $\Lambda\acute{\epsilon}\xi\iota\varsigma$ . They implied existence. On the right hand side, the Universal Negative, **E**, and the particular negative **O**, encompassed by the term  $\phi\acute{\alpha}\sigma\iota\varsigma$ .  $\Lambda\acute{\epsilon}\xi\iota\varsigma$  is the principle of choice of existence,  $\phi\acute{\alpha}\sigma\iota\varsigma$  is only a say 'yes' or 'no' to the attribute.

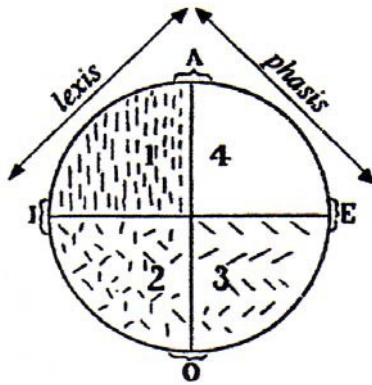

Cf.: This thesis, Chapter 5, p.307

The logic of lack concerning the subject was supported by the topological surface of the torus introduced in Seminar Book IX, *Identification* (1961-1962). The modalities of lack in relation to the object were the structures of *privation*, *frustration*, *castration*. They also defined the subject's three identifications, to the Father, as *Ideal*, to the *phallus*,  $i'(a)$  in the Oedipus complex (ideal identifications) and to desire,  $i(a)$  of object  $a$ , in symbolic castration.

The *torus* was a surface without an edge, and as such equivalent to a sphere, but it delimited an internal and an external space. Therefore it was bilateral. <sup>34</sup> It had also two irreducible voids, an internal, called ‘the soul’ of the torus, and a central void (Cf.: This thesis, Chapter 6, 338).

The vectorialized polygon generating the torus. <sup>35</sup>

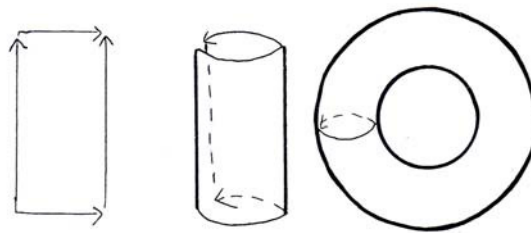

Granon-Lafont, J., 1985, op. cit., p. 49

A torus can be built from a polygon whose opposite sides have the same direction, be folded and form a cylinder whose ends are joined to form a doughnut.

We showed already the construction from a sphere from which one extracts a handle.

Lacan used the latter to inscribe the graph of desire. <sup>36</sup>

---

<sup>34</sup> Granon-Lafont, J. , (1985), op. cit., p. 48-49.

<sup>35</sup> Conté showed a similar schema, (1993), *Topologiques (Surfaces)*, op. cit., 433.

<sup>36</sup> Lacan, op. cit., 21 March 1962, 151.

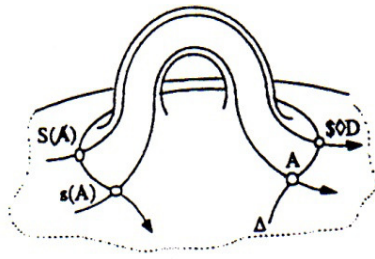

Lacan, J., Op. cit., session 21 March 1962, 151 (Cf.: This thesis, Chapter 6, p. 337).

The surface on which it was possible to show –although topologically disputed- the crossing from the phallus to object *a*, was *the cross-cap*. In order to introduce the cross-cap surface we need to remind that it is the topology of the projective plane and that a projective plane known as *Schema R* figured in Lacan’s ‘On a Question Prior to any Possible Treatment of Psychosis’ (Dec.1956- Jan.1958)<sup>37</sup>

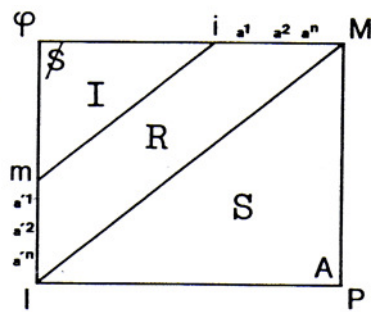

Granon-Lafont, J., op. cit., 83

<sup>37</sup> In *Ecrits* (1966), 446 for the English translation. Lacan reminded his readers accustomed to his topological presentations (2006, 462) that the R schema laid flat the cross-cap, and the strip R, the real, with which he was concerned, boiled down to the cut of the Moebius strip on a cross-cap.(Op. cit., note 14, p. 486-487)



The lines MI and mi are not parallel but they cross-check at each point starting from I and I, M and m and continuing with the other points. They delimit the field defined by Lacan as the Real.

We can obtain the same field of the Real in the cross-cap.

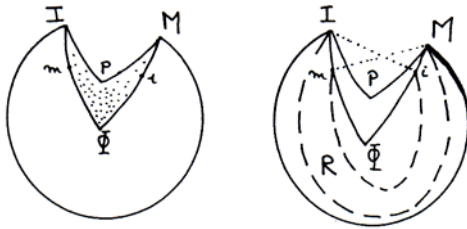

‘The square of Schema R takes the form of a pocket or a sphere missing a bit. We can then write on its surface the letters of schema R.’ It is the cut of the Moebius strip showing the structure of fantasy, the fundamental fantasy which joins and separates the subject and the object of desire. ‘Fantasy constitutes our window, our frame of the perception of reality.’ (Granon-Lafont, J., *ibid.*)

A half sphere with a cross-cap or bishop’s mitre at the top.

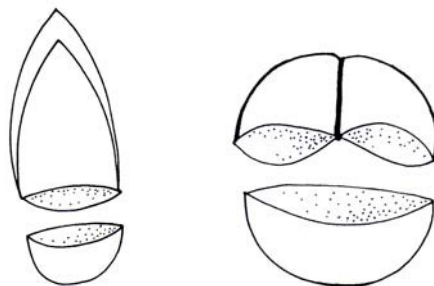

(Granon-Lafont, J., *op. cit.*, 75, 73)

Two remarks impose themselves: 1) the cross-cap has two points impossible to imagine, the point of penetration at the top of the cap and the point of cross-cut at the bottom (you have to imagine a piece of cloth on which this surface is formed). One can try to make it in real space but the point of self-penetration is impossible to show). 2) The cut on the cross-cap has a trajectory of double loop or internal eight or Moebius strip crossing from front to back and from back to front. Lacan compared this trajectory to the crossing of phantasy.

The generating polygon of the cross-cap

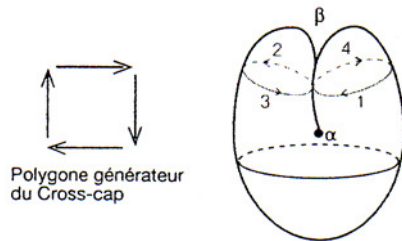

Conté, C., 1993, op. cit., 347

The two points  $\alpha$ ,  $\beta$  of the disputed topologically penetration and the trajectory of the double loop cut 1234 as shown in the cross-cap delimit the trajectory of fantasy.

We can make other cuts further down without slicing it and allow a glimpse of *object a*.

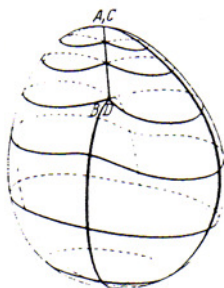

But let us return for a moment to the graph of desire on which Lacan underlined the difference between message and question to inscribe the subject's emergence as lack, in the four points of discourse (Lacan, J., op. cit., 21 March 1962, p. 152). It was his answer to Kant's table of nothing (*Nichts*).<sup>38</sup>

Perhaps nothing and nothing perhaps<sup>39</sup>

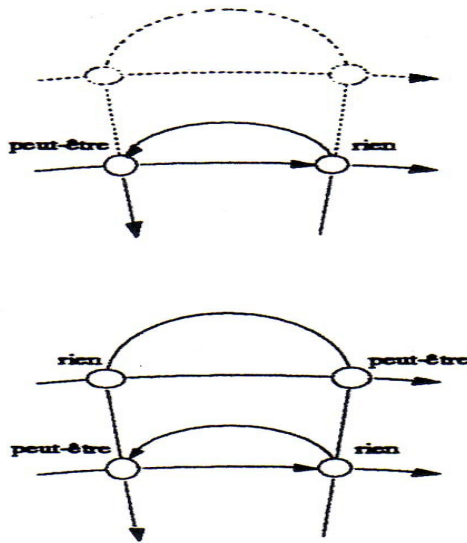

At the lower level: 'Perhaps?..... Nothing.....':

The level of the message, it says there is a possibility on the side of the subject.

At the upper level: 'Nothing ..... Perhaps? .....':

<sup>38</sup> *ibid.* In Seminar Book IX, *Identification*, session 7 March 1962, 134, this is what Lacan had to say about the subject as the missing count of the 'unary repetition' on the single torus: 'insofar as the subject traces the successive rounds of his demand, he is necessarily deceived on the one missing count, and we thus see -1, the unconscious, appear as a function.' This is the subject as 'perhaps nothing', as Kant's '*ens privativum*'

<sup>39</sup> Lacan, Seminar Book IX, *Identification*, 21 March 1962, 152.

Concerning the question of desire, there is no answer, but the probability of everything being undetermined, nothing being certain. There is no answer from the Other because the Other does not know.(Cf.: This thesis, Chapter 6, 353).

The difference between message and question

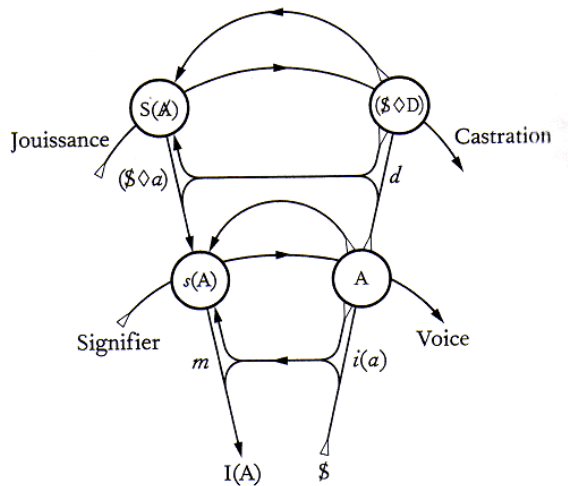

‘In the first line, A . . . s(A): The signification of the message returning to the subject from the Other on the first level A answers the subject’s question with the signifier which resides in the Other s(A).’

‘In the second line, \$ \diamond D...S(A barred): The relation of the subject to demand insofar as it is specified in the drive (\$\diamond D)\$ returns as his own question, because the Other cannot be formalized , S(A barred), he is also marked by the signifier, . . . there cannot be a metalanguage.’<sup>40</sup>

Like in the two intertwined toruses similarly in the graph of desire a moment of *anxiety* arises when the subject is confronted to the desire of the Other:

---

<sup>40</sup> Ibid.

‘The two intertwined toruses by their topology suggest that the desire of the subject *has no common measure* with the desire of the Other. Indeed, there is no possible contract on the level of desire. But, desire necessarily includes the *x* of the Other’s demand, hence anxiety perhaps. Looking at the Other’s mirror I do not see my insignia (non-specular); I meet his demand with the question: *what can he possibly want of me?*’<sup>41</sup>

Graph of Desire, *chè vuoi?* The hook of the Other

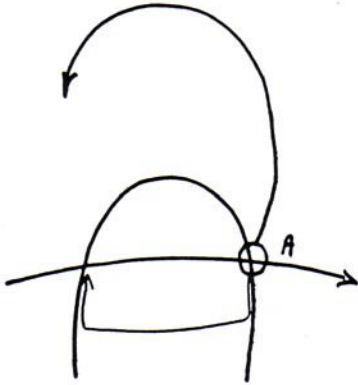

Conté, C., *Topologiques (Surfaces)*, op. cit., 435.

As Conté put it, to the question ‘what do you want’, *che vuoi?* (as in the novella by Gazotte, *The devil in love*), uttered by the subject at the level of enunciation, the Other’s answer is a mere echo, *che vuoi?* an empty space, a non-answer because the Other cannot answer, is also barred by the signifier, *S(A barred)*.

This was the dissymmetry which Lacan formulated in the logic of *perhaps- nothing* and *nothing- perhaps* (Cf.: this thesis, Chapter 6, 350-351). On the first level of the graph at the moment when ‘the subject enters the real’ the message is: it is possible:

‘It is not on the side of the Thing that it is possible, but on the side of the subject. The message opens in terms of possibility constituted by the expectation (*attente*) in the

---

<sup>41</sup> Conté, C., op. cit., 435. The famous *chè vuoi?* ‘What do you want?’ at the top level of the graph of desire, originates in J. Cazotte’s novel, *Le diable amoureux*, Gallimard, 1981.

situation constitutive of desire...perhaps, the possibility exists before the nominative 'nothing' which takes the value of substitute of the positivity. It is a point, that's all. The place of the unary trait is there reserved in the void and can respond to the expectation of desire'.

At the second level, 'nothing perhaps?' is perhaps an answer but not an answer to the first question. Everything remains undetermined, there is no conclusion, it is impossible to conclude. As Lacan says, 'only the eventuality of the real allows something to be determined and the nomination of nothingness (*néant*) of the pure subsistence of the first question, this is what we have to deal with at the level of the question'.'<sup>42</sup>

At that level, the Other's impotence to answer is rooted in an impossible, which is the same as what has led us to the question of the subject . . . '*Not possible* was the void where the dividing value of the unary trait emerged . . . desire is defined as the intersection of that which in the two demands 'is not to be said' (*n'est pas à dire*).<sup>43</sup>

Facing the anxiety of what cannot be said, *castration*, the subject will propose the phallus as the answer to the lack in the Other. There is another possible way, we saw it in the articulation of demand and desire which the two intertwined toruses and their possible intersection (Cf.: This thesis, this chapter, 342)

---

<sup>42</sup> Lacan, J. *L'identification*, 21 March 1962, 152.

<sup>43</sup> *Ibid.*, 153.

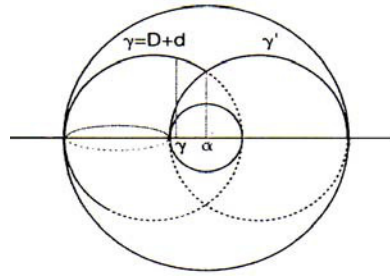

Conté, C., *Topologiques (Surfaces)*, op. cit., 435.

The full schema of the intersection within the two intertwined torus, shows the phallus as the diameter of trajectory  $\gamma$  (demand  $D$ +desire  $d$ ) whose perpendicular falls within the empty circle, fro the subject. Thus ‘The phallus gives the measure of the field to define within demand, which is desire.’<sup>44</sup> Within the empty circle we also find object  $a$ , but in a different way for the subject, as Conté notes:

‘I do not know the Other’s desire but I know its instrument, the phallus’: there is a paradox for the little boy, who in order to enter symbolic castration has to demand the phallus, by pawning the penis, the ‘bit of flesh’, by ‘allowing a levying on the enjoyment of the organ’.<sup>45</sup>

Freud thought that every analysis stumbled at the rock of castration, and could become interminable demand. Although he recognized that analysis could sometimes end with the acceptance of castration by both sexes, he argued that most of the times it failed. But for Lacan analysis was at the same time ‘finite’ and ‘infinite’, and this was the translation he proposed in French for Freud’s (1937) *Die endliche und unendliche Analyse*. Lacan thought that there was a possible end through object  $a$ . The neurotic’s solution undoubtedly passes

---

<sup>44</sup> Conté, C., op. cit., 435.

<sup>45</sup> Ibid.

by the phallus, he/she identifies with it, while the object of desire remains at a distance. The desire of the hysteric remains unsatisfied while she tries to sustain the desire of the Other. But her own desire is supported by the question of ‘what is a woman’ (in hysteria, as Conté noted, the object is homosexual. The hysteric demands the object of the Other).

Conté’s schema L with the desire of the hysteric.

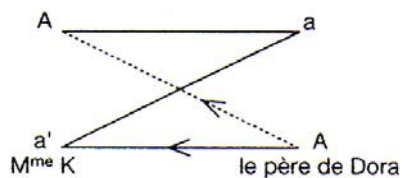

Conté, C., *Topologiques (Surfaces)*, op. cit., 436.

On the other hand, the desire of the obsessional is sustained by the impossible. It is a quite a destructive desire which, in its construction, implies a dead man. It is therefore quite difficult to sustain. There is very little anxiety in both neuroses. Phobia is a first step towards a solution by the object, as the object which causes anxiety is between an object-cause of desire, but also has a phallic function. Anxiety in that context is not the fear of *aphanisis* of desire, as Ernest Jones put it, but of *aphanisis* of the phallus, a fear of losing the phallus, anxiety of castration,  $-\phi$ . Lacan in his Seminar Book X (1963-1964), *Anxiety argued that* anxiety of castration was not necessarily the end point of analysis. There was another way.



There is another way to inscribe the intersection which as De Morgan showed can extract a field, a field 'defining the symmetric difference', the *either or* of logical exclusion. This cannot be done on the torus but on the cross-cap and the Klein bottle.

Lacan used the topological surfaces not only to show the structure of the subject via the operations of privation, frustration, castration, the three forms of his identification and the logic of the subject's lack, but also the logic of a cut imposed by the object of desire, and the structure of fantasy it determined. 'Going through the fantasy' in analysis was necessary in order to have a glimpse at the object cause of one's desire. For the latter the topological objects Lacan used existed in another, non Euclidian space. They were evolving in a fourth or even fifth dimension, they were the cross-cap and the Klein bottle, the latter was developed in Seminar Book XII, *Crucial problems for Psychoanalysis* (1964-1965). They could be laid flat on the drawing board, and show the trajectories of the psychoanalytic operations, the *crossing of fantasy* in the cross-cap, *interpretation*, *transference* and *the end of analysis* in the Klein bottle. Some cuts were themselves a surface; such was the *internal eight* or otherwise *double loop*, a loop which creating an internal and an external space 'homogenizes' them. It was the surface Lacan chose to show a De Morgan intersection, he called it 'internal eight'.

'Internal eight' or double loop surface and the topology of the subject.

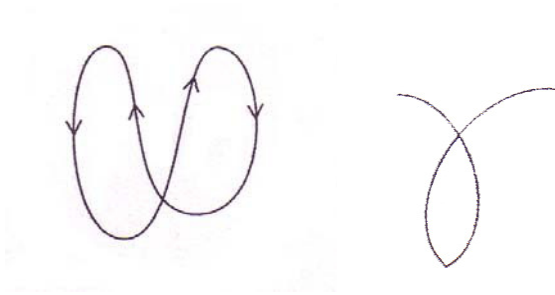

Lacan, J., *Identification*, Session, 2 May 1962, [210]

The displaceable, deformable line of the double loop stands for the phallus which can introduce any subject in the field of desire. This was the case in the cross-cap cuts we showed above (Cf.: this thesis, Chapter 6, 349).

The double loop cannot be done on the torus, where it misses object *a*. The subject as excluded from the field of the signifier designates the space of the Real (R)

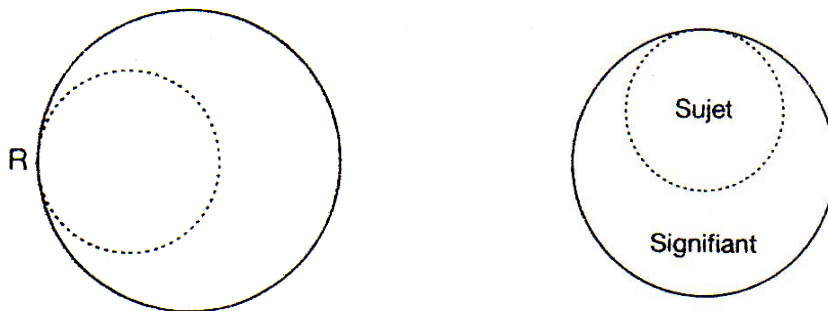

Conté, C., 1993, op. cit., 438.

Making a double loop cut around what is supposed to be the central point (hole) takes away with it the structure of the cross-cap: a small disk falls off. The double loop cut extracts object  $a$ , the disc, - assuming that the point of penetration is topologically possible -and leaves a Moebius strip, the subject

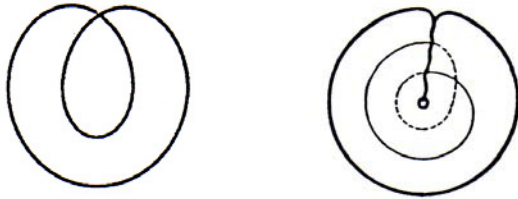

Lacan, J., Seminar Book IX, Identification, 2 May 1962 and 9 May 1962

On the intertwined toruses the field of the intersection could not be extracted. Thus it could show neither the signifier's self-difference, which excludes the subject, nor object  $a$ . On the torus, for the reasons we already explained, we cannot trace a double loop unless we destroy the surface. We then obtain a special kind of knot, called trefoil knot.

Trefoil knot on the torus

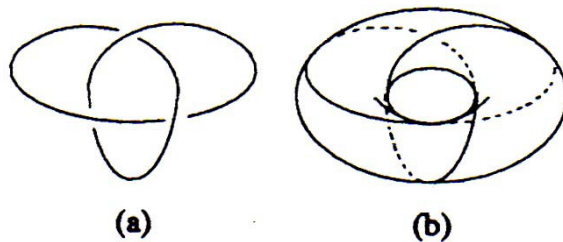

Lacan, J., *Identification*, Session, 2 May 1962, 212-213

The cross-cap was the appropriate surface to show the trajectory of fantasy. The cut ‘interior eight’ on the cross cap surface is ‘orientable,’ it has a left and a right hand direction , but it has no mirror image, it is asymmetrical. Object *a* has no image in the mirror

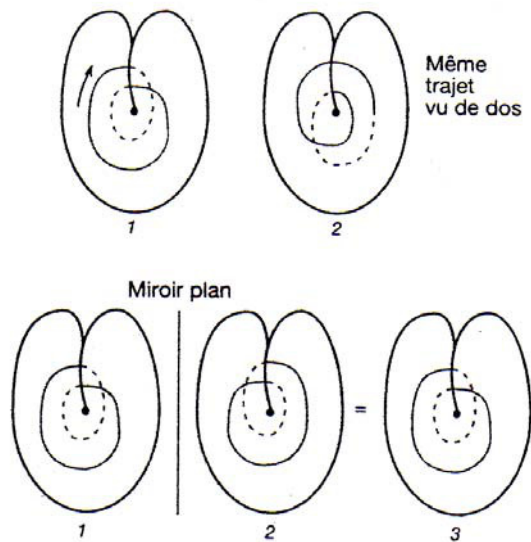

Conté, C., Topological (surfaces), op. cit., 440.

We need here to remember that the topological surfaces are objects, some of which exist in Euclidian space, such as the Moebius strip and the torus, others which can only be shown on a virtual space of four or more dimensions or drawn on a piece of paper. In the latter case they become representations and as such create an imaginary which is not there.

Conté argued that the topology of the cross-cap supported the relation ‘to the image of the body which Lacan called secondary narcissism and which takes all its weight from the fact that it is linked with the relation to the object which characterizes the fundamental fantasy.’

Always according to Conté, there are here two imaginaries:

1. A false imaginary, the mirror image, which supports the mirages of ‘misrecognition’. It takes its consistency by
2. A true imaginary, effect of the relation of the body to the Other, as foundation of the subject of discourse.

This is what Conté tells us then:

‘The fantasy is situated at the point of the Other’s fundamental failure as locus of speech, [marked as] *A* barred, the ultimate failing of the universal witness. Object *a* is situated at that point of the Other’s failure, of the Other’s absence, which is also the point from where the subject receives from the Other the *unary trait*, a turning point [in the process] of its rejection from all signifying realization.’<sup>47</sup>

The phallic function is then identified to the hole of the cross-cap, the common point of emergence:

Of the subject as \$

Of object *a* which makes desire authentic giving it the property of the cross-check surface of the cross-cap.’ (Conté, *ibid.*)

However this account leaves many questions unanswered concerning the *Real* and object *a*.

Lacan started developing the idea of a ‘beyond the roc of castration’ using Freud himself in Seminar Book X, *Anxiety* (1962-1963). The Seminar presents what Lacan considered to be another topography (*topique*) of Freud, based on his second theory of anxiety in ‘Inhibitions, Symptoms and Anxiety’ (1926d). In Seminar Book X Lacan constructed another table where he placed *Inhibitions*, *Symptoms*, and *Anxiety*. So, for Lacan two topographies were considered as possible transitions from the established first and second topography to Freud’s later developments – and there could have been possibly another

---

<sup>47</sup> Conté, C., *op. cit.*, 440.

topography with the *Ichspaltung* (1940[1938e]). In the same Seminar and continuing from Seminar IX, *Identification* (1961-1962) Lacan declared that anxiety was not a signal of the object lacking, but of the *lack of its lack*.

The table Inhibitions, Symptoms and Anxiety

Inhibition Impeachment		Embarrassment
Emotion	Symptom	Passage to the Act
Emotion (Emoi)	Acting out	Anxiety

(Lacan, J., Seminar Book X, 19 December 1962)

### III Conclusion

#### A. The trajectory of the Freudian Ich, from Identification to Anxiety.

In the first part of this thesis I have underlined and developed the idea that Freud's *Ich*, was mistaken most of the times as the ego of consciousness, psychical unity and adaptation to the demands of external reality. I argue that it was a more complex structure which covered all the aspects of what Freud had called the psychical reality and even coming close of what Lacan had called the *divided subject*. Narcissism, introduced by Freud in the middle period of his works (1914-1918), widened the field of applications of his libidinal theory to psychosis and the narcissistic neuroses. He introduced distinctions between primary and secondary narcissism, and between between ego ideal and ideal ego which can be compared to Lacan's theory of the imaginary register of the ego. In the third period of his work (from 1918 onwards) and after the introduction of the compulsion to repeat and the death drive, a revision of his first topography became necessary. In that third period, examining Freud's theory of identification, in 'Group Psychology and the Analysis of the Ego' (1921c), I put to the test J. Florence's thesis that all identification in Freud was narcissistic, that it was in Lacanian jargon identification to the specular other, and claimed that identification in Freud had also to do with the subject's desire; This is why one had to distinguish between ego ideal and ideal ego. Ego ideal was on the symbolic level, an identification to the Father, while ideal ego was an identification to the specular image of the little other. Then one had to distinguish between the ego ideal and object *a*.

Lacan argued on both points. Already in his Seminar Book I, *Freud's Papers on Technique* (1953-1954), he supported their difference with Freud's theory of the two narcissisms. But, in Seminar IX, *Identification* (1961-1962), what he underlined was that Freud's third identification was identification to desire, the desire of the Other, that it involved object *a*. Behind *I*, the ego ideal, there was object *a*, its non-specular image, *i(a)*, was the stuff of fantasy and *i'(a)* its specular image, the image of the body. Object *a* does not have a specular (mirror) image, but all identifications concealed that object under the ideal signifiers of the subject and the first identification to the ego ideal too (op. cit., 20 June 1962). In that Seminar priority was given to Freud's second identification to the one trait only, but quite early on he turned his attention to the problems arising not from the narcissistic image, but from anxiety in relation to the desire of the Other in the third kind of identification. He left the first identification for some time and only approached its enigmas towards the end of his teaching, in Seminar XXIV, *L'insu que sait de l'unebevue s'aile à mourre* (1976-1977).

In Chapter 4, I explained Lacan's *optical schema*, as he developed it in 'Remarks to Daniel Lagache's Presentation' (Ecrits, 1966 [1960]), and why although with the optical schema Lacan articulated the symbolic and the imaginary orders, he was forced to left the real undeveloped, given the fact that in its structure the optical schema was based on the specular function. It could not show the true status of *object a*, which as we said, is non-specular.



In Chapter 5, I moved to the core of this thesis. I examined the important aspects of Lacan's essentially philosophical but also very original theory of identification in his eponymous Seminar (Book IX, 1961-1962). I argued that he definitely introduced the *Real* as a special topological space, impossible to imagine. His developments took off particularly concerning the object of anxiety in Seminar Book X, *Anxiety* (1962-1963). I presented some aspects of it. In Seminar IX, the signifier found an exemplary formulation in what he defined as the 'unary trait', Freud's *einzigster Zug*, the *second* form of *identification*. His developments signifier as letter, the theory of the proper name, and the conjecture of writing, showed us that Lacan was moving away from the structure of the unconscious as language, as metaphor and metonymy, to the register of the real not only for the object but also for the subject. Topology showed how the signifier could enter the real in the cross-check of the internal eight or the reduced cross-cap surface. Topology became essential for the transmission of psychoanalysis. We showed the topological surfaces of the torus, the cross-cap and the Klein bottle, the latter from Seminar Book XII, *Crucial problems of psychoanalysis* (1964-1965). We showed the Moebius strip and the trajectory of the subject in the Klein bottle essential for identification, transference and the end of analysis. The operation of crossing of the fantasy was shown with the internal eight cut on the cross-cap around 'the point of penetration'. Except for the Moebius strip the other surfaces involved the register of the Real and object  $a$  .<sup>48</sup> The Moebius strip showed rather the progression of the signifying chain.

---

<sup>48</sup> Lacan on finding the *internal eight* in Peirce: see Seminar IX, *Identification*, 23 May 1962, where he expresses his admiration for the American philosopher of Logic.

*Crossing of fantasy* was a term introduced after Lacan to designate the analytic operation necessary for going beyond what Freud had called ‘the rock of castration’ in the man, and ‘penisneid’ in the woman. Indeed this was an obstacle on which, according to Freud, all analytic treatments floundered. In his Seminar Book X, *Anxiety* (1962-1963), Lacan argued that another end of analysis was possible and anxiety of castration was not an obstacle in itself: ‘Anxiety of castration is already there in  $-\phi$ , at the level of the fracture when we approach the libidinal image of the fellow other’ (see below ‘the simplified optical schema’),<sup>49</sup> something which causes all sort of dramas and emotional traumas. But it fiercely emerges too, when in the place of absence in  $-\phi$  something appears. Our image of ourselves as supported by the Other, big A, is sustained by an absence, but this absence is what causes desire. If something appears in place,  $-\phi$ , this is what causes ‘real’ anxiety. So, what the neurotic backs away from is not imaginary castration but, as Lacan put it, ‘what he cannot stand is to make his own castration what the Other lacks, to make his own castration something positive, the guarantee of the Other’s function . . .’,<sup>50</sup>

The simplified optical schema

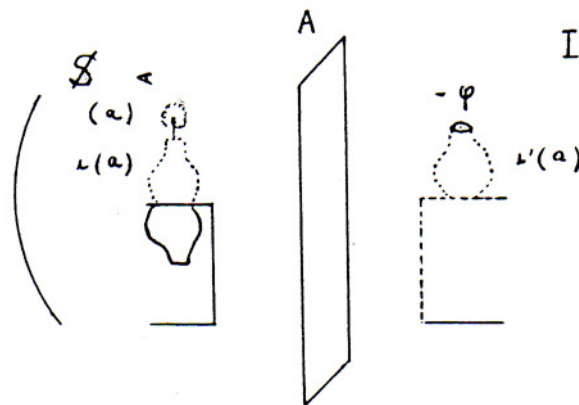

<sup>49</sup> Lacan, J., op. cit., 5 December 1962: 50.

<sup>50</sup> Ibid., 58.

Conté, C., On Anxiety (1964), in 'The real and the sexual'(1992, p.15).

In Seminar Book XII, Crucial Problems of Psychoanalysis (1964-1965), Lacan constructed on the board another topological surface known as Klein bottle. It is a surface in which the external and the internal space are in continuity, and it is a closed surface. The subject in the treatment moves from the circles of demand around object *a* to the other side without noticing it, but at the end with a cross-check leap at the bottom it can realise his position as the reverse of the decor, which is to say he realizes his identification to object *a*. The subject thus can realize the way he inhabits the structure.

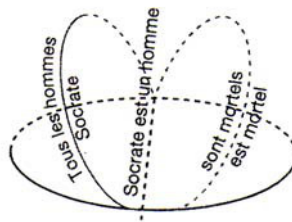
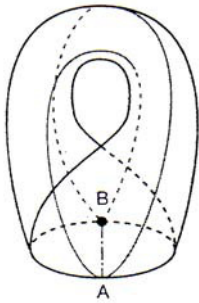
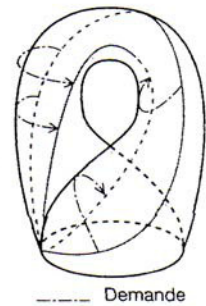
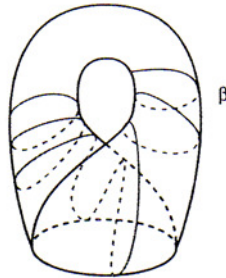
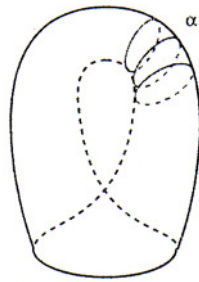

Seminar Book IX, *Identification* (1961-1962) is a preliminary to both Seminar Book X, *Anxiety* (1962-1963) and Seminar Book XII, *Crucial Problems for Psychoanalysis* (1964-1965) and this makes it particularly important.

I placed a particular emphasis in the last part of this thesis on the importance of topology and in particular of the topological surfaces in the formalizations of the middle period of Lacan's teaching. Topology indeed continued to interest the late Lacan (after 1972) with the use of the Borromean Knots. Topology is an important tool to show something concerning the Real.

I claim therefore that Lacan turned his developments in Seminar IX, *Identification*, to introduce the register of the Real and make object *a* inhabiting this space. The Real was the fourth dimension of the topological surfaces he used in Seminar IX, the inexistent space, as he said much later (*L'Etourdit*, 1972), but made already obvious from Seminar IX onwards. Thus we claim that he did not introduce the Real in Seminar Book XI, *The Four Fundamental Concepts of Psychoanalysis* (1964), as it is widely accepted. In 1960 the six volumes of Peirce's *Collected Papers* were published. Lacan said that he found there his unary trait not as a signifier but as a sign, as letter as sign of the subject who excluded from the symbolic inasmuch as he speaks finds himself in the Real, but he was already there from the beginning. With the proper name and the conjecture on the origins of writing a common space was found between symbolic and real in the projective plane which took into account the logic of lack, Although the third register was already in Lacan's theoretical

arsenal since 1953, as his famous lecture of 1953 testifies, it had been left to the side for quite a while.

**B. Why Conté's choices of Lacan's concepts from the second period of his teaching were important in the Lacanian orientation.**

Claude Conté is practically unknown to the English public. Only one of his papers, 'The Phallic Phase and the Subjective Importance of the Complex of Castration(1968) was translated in English and published in *Feminine Sexuality, Jacques Lacan and the Ecole Freudienne de Paris* (1982), a selection of texts by Lacan and eminent analysts of his School, edited by J. Mitchell and J. Rose. Published first in *Scilicet*, no 1, the external publication of the *Ecole Freudienne de Paris*, the paper was not signed, as was the use. Conté's papers remain largely unknown in the English speaking world, despite their importance as the earliest attempts to present difficult and complex aspects of the Lacanian teaching as it was delivered. He has not been translated and there are no commentaries of his work, either, as far as we know. However he was one of the prominent first generation of analysts formed by Lacan himself, one of the first AME, analysts members of his School since its foundation in 1964, and an AE (Analyst of the School), soon after. He was a member of its Directorate from the start and responsible for the School's internal bulletin, *Lettres de l'Ecole Freudienne*. He continued his teaching and research after the School's dissolution in 1982, formed with a few others one of the largest psychoanalytic associations in the post-Lacan era, the Cartels Constituants d'Analyse Freudienne(1983) and published extensively while continuing his practice as an analyst. two of the Lacanian

One of his earlier publications was his paper 'On anxiety' (*Sur l'angoisse*<sup>1</sup>, 1964) where most important formulations from the Seminar *Anxiety* (1952-1963), while his choice reflected his own interest in the theme of anxiety, as he had been already researching Goldstein's theory of 'catastrophic reaction' and published on the subject in the medical journal '*L'Encéphale*' (1961). 'On anxiety' was published as Internal Document of Research of the EFP. It was followed by 'On the way the part drives present themselves in the treatment', presented in the study days of September 1972, and published in 1973 in '*Lettres de l'Ecole Freudienne*', no 11. 'The Clinical application of the Graph' (*La Clinique du Graphe*), another important paper, was published in *Lettres de l'Ecole Freudienne*, no 21 in 1976.

He continued writing, teaching and researching for the next twenty years of his life. In 1991 together with a few others he left the *Cartels Constituants de l'Analyse Freudienne* to form the organization *Analyse Freudienne*. During the last decade, he worked on the themes which most interested him, the formation of the analyst and the pass, and published again his research, namely on 'Transference and de-subjectification' (1983), and 'Pass and the Practice of Analysis' (1988). His 'Pass and Exploration of the Real as Impossible' (1991) and other papers of that final year were only published posthumously. 'Short Remarks on the dimension of the Real in Jacques Lacan's teaching', also of 1991, was published in *Esquisses Psychanalytiques*, no 5, now precious for their emphasis on the importance of the *Real* in Lacan's teaching. He considered the Real as 'the Lacanian field', next to Freud's Unconscious as 'the Freudian field'. All his papers were assembled and published with the appropriate title 'The Real and the Sexual' shortly before his death in 1992. Three

more articles appeared posthumously in *L'Apport Freudien*, Elements for an Encyclopedia of Psychoanalysis (1993), on the headings, The Graph, the Paternal Metaphor, and the 'Topological Surfaces' .

This research was inspired by some of his ideas, especially the parallels between splitting and identifications of the subject from one of his most significant early papers 'The splitting of the subject and its identification', first published in *Scilicet* no 2-3, in 1970. He tackled the fundamental themes of Lacan's Seminar Book IX, *Identification* in which he assisted and took notes, the subject and knowledge, the logic of lack, the splitting and the division in the subject's identifications. One of Conté's last papers, published in 'L'Apport Freudien', *Elements for an Encyclopedia of Psychoanalysis*(1993) was an exposition of all Lacan's 'Topological (Surfaces),' from Seminars IX and XII. Conté was able to develop and clarify some the most complex theoretical issues in Lacan's teaching and show their importance for the clinical practice. He followed the Seminars assiduously, he took manuscript notes and kept a record of all the Seminars he followed which he made available to the publications of the Seminars (edited or non edited internal publications). When Lacan was alive he was one of the few he encouraged to do exactly that work, of presenting aspects of his teaching in his own way. In later years he assisted other, younger analysts in their own research. Thus, his sudden and tragic death attracted tributes and testimonies of his pupils for his presence as an analyst in the first generation following Lacan.

### C. Predominance of the Real

Finally, we need to emphasize that this research leads us to emphasize anew the Real, as the less noticed territory of Psychoanalysis (theory and practice), a direction which Lacan's took from the middle to the late period of his teaching. The register of the real is not something mythical or mystical. One can say succinctly that it is the other side of truth and the unconscious. It is the subject as inhabiting a space topology can only explore, 'difficult to imagine' or 'unreal', and it is the logical category of the 'impossible'. It is what comes back always in the same place as Lacan said in Seminar IX. In the clinical practice it meant the impossible of the sexual relation. Therefore we need to develop and understand better what it means.

Freud, who somehow was embarrassed with his distinction between psychical and external reality, in whose topographies something always slipped every time he tried to redefine them, had, we suggest some idea about the enigma of the real. For example in his short theoretical text of the *Ichspaltung* (1940e[1938]) he left us with the question of why can the perception of the female genital organs create an anxiety of castration in as far as there was nothing already there before. The real is full, still there is the perception of a lack in reality which causes anxiety and a symptom, a phobia and anxiety of being devoured by the Father. That gaping hole, we could say, is the only thing we know about the real.

In one of his last notes Freud wrote: *Mystik, die dunkle Selbstwahrnehmung des Reiches ausserhalb des Ichs, das Es*: Mystic, the dim self-perception of the realm outside the *Ich*, which is the *id*. (in *Ergebnisse, Ideen, Probleme*, London, June 1938, 22, G.W., VIII.,



Schriften aus dem Nachlass, 1892-1939 and Resultats, idees, Problemes, a translation in french published in 19...). Now, because the term of 'mystic' can lead to misunderstandings, we better define the real as Lacan did, as the impossible. We can retain from the above definitions of the real, the topological one, the edge or rim of the hole, and the logical, the category of the impossible.

The real as the impossible to say (*l'impossible à dire*) was emphasized by Lacan in L' *Etourdit* (1971), and object *a* was for a time standing for it in the gap of the projective place or the hole around which he tied the Borromean knot which 'fitted like a ring in his [Lacan's] finger' (Seminar Book XIX, *Ou pire . . .* 1971-1972).

Abraham, K., 'Notes on the Psychoanalytical Investigation and Treatment of Manic-depressive Insanity and Allied Conditions' (1912), *Selected Papers on Psychoanalysis*, London, International Psychoanalytic Library, Hogarth Press Ltd, 1927, reprinted London, Karnac Books, (1979)

Abraham, K., 'The First Pregonital Stage of the Libido' (1916), *Selected Papers on Psychoanalysis*, London, International Psychoanalytic Library, Hogarth Press Ltd, 1927, reprinted London, Karnac Books, 1979.

Allouch, J., 'La conjecture de Lacan sur l'origine de l'écriture', *Littoral* no 7-8, Paris, érès, (1983).

Aristotle, *Nicomachean Ethics*, Loeb Classical Library, Vol. XIX, Harvard University Press, Cambridge Massachusetts, (1926).

Aristotle, *On Interpretation*, Loeb Classical Library, Vol. I, Harvard University Press, Cambridge Massachusetts, (1973).

Balint, M., *Primary Love and Psychoanalytic Technique*, (1952, reprinted London, Maresfield Library reprint, 1985).

Burgoyne, B. and Leader D., 'A Problem of Scientific Influence', Newsletter of the Centre of Freudian Analysis and Research, no 13, 1988

Bursztein, J-G., *Qu'est-ce que l'appareil psychique?*, (Paris, Nouvelles Etudes Freudiennes, 1999).

Bussanich, J., *The One and its Relation to the Intellect in Plotinus*, (Leiden, Brill, 1988).

Conté, C., 'Sur l'angoisse', (in 'Documents, Recherches et Travaux', internal publication of the EFP, 1964, reprinted in *Le réel et le sexuel*, Paris, Point Hors Ligne, 1992).

Conté, C., 'Le clivage du sujet et son identification', (*Scilicet* no. 2-3, 1970, reprinted in '*Le réel et le sexuel*', Paris, Point Hors Ligne, (1992).

Conté, C., 'La clinique du graphe', *Lettres de l'EFPP* no. 21, 1977, reprinted in *Le réel et le sexuel*, Paris, Point Hors Ligne, (1992).

Conté, C., 'Brèves remarques sur la dimension du réel dans l'enseignement de Jacques Lacan', 1991, in '*Le réel et le sexuel*', Paris, Point Hors Ligne, (1992).

Conté, C., 'Topologiques (Surfaces)', *L'apport freudien*, Paris, Bordas, (1993).

Cruglak, C., 'Identification primaire, incorporation', ('Les Carnets de Psychanalyse', no 2, Paris, 1991-1992)

Dagfal, A., 'La psychanalyse à l'intérieur de la psychologie: les avatars du projet de Daniel Lagache', (*Essaim*, No 9, Paris, érès, (2002).

Darmon, M., *Essais sur la Topologie lacanienne*, (Paris, Editions de l'Association Freudienne, 1990).

De Saussure, F., *Cours de Linguistique Générale*(1915), (Paris, Payot, 1972)

Descartes, R., *Discours de la Méthode* (1636), (Paris, Garnier-Fammarion, 1966).

Descartes, R., *Meditationes de Prima Philosophia*, (1639-1640), (Paris, Librairie Philosophique Vrin, J., 1978).

Dor, J., *Introduction à la Lecture de Lacan*, (Paris, Denoel, 1992).

Dorgeuille, C., & Conté, C., 'La question du sujet: Débat', *Etudes Freudiennes*, no 33, Paris, April (1992).

Dreyfuss, J.P., 'Remarques sur das Ding dans l'Esquisse', in *Littoral* no 6, Paris, érès, (1982).

Evans, D., *Dictionary of Lacanian Psychoanalysis*, (London, Routledge, 1996).

Ferenczi, S., 'La confusions des langues entre l'enfant et l'adulte', in *Oevres Completes*, (Paris, Payot, 1982).

Février, J.G., *Histoire de l'écriture*, (Paris, Payot, 1959).

Fink, B., *Jacques Lacan Ecrits*, (London, New York, W.W.Norton & Co., 2006).

Frege, G.F.L., *Les Fondements de l'Arithmétique*, (1884), (Paris, Seuil, 1969).

Florence, J., *L'identification dans la théorie freudienne*, (Bruxelles, Presses Universitaires Saint-Louis, 1978).

Freud, S., 1894a, 'The Neuro-Psychoses of Defence', Standard Ed., **3**

Freud, S., 1895d, 'Studies on Hysteria', Standard Ed., **2**

Freud, S., 1899a, 'Screen Memories', Standard Ed., **3**

Freud, S., 1900a, 'The Interpretation of Dreams', Standard Ed., **4 & 5**

Freud, S., 1905d, 'Three Essays on the Theory of Sexuality', Standard Ed., **7**

Freud, S., 1908e, 'Creative Writers and Day Dreaming', Standard Ed., **9**

Freud, S., 1910c, 'Leonardo Da Vinci and a Memory of his Childhood', Standard Ed., **11**

Freud, S., 1910i, 'The Psychoanalytic View of Psychogenic Disturbance of Vision', Standard Ed., **11**

Freud, S., 1911b, 'Formulations on the Two Principles of Mental Functioning', Standard Ed.,  
**12**

Freud, S., 1911 c, 'Psychoanalytic Notes on an Autobiographical Account of a Case of  
Paranoia', Standard Ed., **12**

Freud, S., 1912-13, 'Totem and Taboo', Standard Ed., **13**

Freud, S., 1914c, 'On Narcissism: an Introduction', Standard Ed., **14**

Freud, S., 1914g, 'Recollecting, Repeating and Working Through', Standard Ed., **14**

Freud, S., 1915b, 'Thoughts for the Times of War and Death', Standard Ed., **14**

Freud, S., 1915c, 'Drives and their Vicissitudes', Standard Ed., **14**

Freud, S., 1915d, 'Repression', Standard Ed., **14**

Freud, S., 1915e, 'The Unconscious', Standard Ed., **14**

Freud, S., 1917d, 'Metapsychological Supplement to the Theory of Dreams', Standard Ed.,  
**14**

Freud, S., 1917e [1915], 'Mourning and Melancholia', Standard Ed., **14**

Freud, S., 1918b[1914], 'From the History of an Infantile Neurosis', Standard Ed., **17**

Freud, S., 1920g, 'Beyond the Pleasure Principle', Standard Ed., **18**

Freud, S., 1921c, 'Group Psychology and the Analysis of the Ego', Standard Ed., **18**

Freud, S., 1923a, '*Psychoanalyse*' and '*Libido Theorie*', tr. as 'Two Encyclopedia Articles',  
Standard Ed., **18**

Freud, S., 1923b, 'The Ego and the Id', Standard Ed., **19**

Freud, S., 1924c, 'The Economic Problem of Masochism', Standard Ed., **19**

Freud, S., 1925h, 'Negation', Standard Ed., **19**

Freud, S., 1926d, 'Inhibition, Symptoms and Anxiety', Standard Ed., **20**

Freud, S., 1927d, 'Humour', Standard Ed., **21**

Freud, S., 1927e, 'Fetishism', Standard Ed., **21**

Freud, S., 1930a 'Civilization and its Discontents', Standard Ed., **21**

Freud, S., (1932b) 'Preface to Hermann Nunberg's *General Theory of the Neuroses on a Psychoanalytic Basis*', Standard Ed., **21**

Freud, S., (1933[1932]), '*Lecture XXXI, New Introductory Lectures on Psycho-Analysis*', Standard Ed., **22**

Freud, S., (1940a [1938]), 'An Outline of Psychoanalysis', Standard Ed., **23**

Freud, S., 1940e [1938], 'Splitting of the Ego in the Process of Defence', Standard Ed., **23**

Freud, S., 1942a, 'Psychopathic Characters on the Stage', Standard Ed., **23**

Freud, S., 1950a[1887-1902], *Aus den Anfängen der Psychoanalyse*, London, ed. Freud A., Kris, E., Bonaparte M., Imago Publishing Company, 1950, tr. as *Origins of Psycho-Analysis* (including 'A Project for a Scientific Psychology'), Standard Ed., 1.(1954), Strachey J. In collaboration with Freud, A.

Le Gaufey, G., 'Représentations freudienne et significant lacanien', in *Littoral* no. 14 (Paris, érès, 1984).

Geerardyn, F., *Freud's Project, On the Roots of Psychoanalysis*, (London, Rebus Press, 1997).

Granon-Lafont, J., *La Topologie Ordinaire de Jacques Lacan*, (Paris, Point Hors Ligne, 1985).

Hartmann, H., Kris, E. & Loewenstein, R., 'Comments on the Formation of Psychic Structure', *The Psychoanalytic Study of the Child*, Vol. II, (London, Imago Publishing Co., 1946)

Jekels, L., and Bergler, E., 'Übertragung und Liebe', *Imago*, (Vienna, 1934), tr. in *Psychoanalytic Quarterly*, (London, 1949).

Jones, E., *Sigmund Freud Life and Work*, (London & New York, Vol. 1, 1953; Vol. 2, 1955; Vol. 3, 1957).

Jung, K., (1912), *Wandlungen und Symbole der Libido*, tr. as *Psychology of the Unconscious*, (London, 1919).

Kant, I., (1781), *Critique of Pure Reason*, (Cambridge, Hackett Publishing Co., 1996).

Kneale, W. & Kneale, M., *The Development of Logic*, (London, Clarendon Press, 1962).

Lacan, J., (1932), *De la psychose paranoïaque dans ses rapports avec la personnalité* (Paris, Seuil, 1975).

Lacan, J., (1953), 'Le symbolique, l'imaginaire et le réel', *Bulletin de l'Association Freudienne*, no. 1, 1982

Lacan, J., 'La Science et la Vérité', *Cahiers pour l'analyse* no. 1-2, Paris, Seuil (1966).

Lacan, J., (1966), 'Of Structure as an Immixing of an Otherness Prerequisite to any Subject Whatever, (paper given to International Symposium in Baltimore, in *The Structuralist Controversy*', John Hopkins University Press, 1982).

Lacan, J., (1971), 'Lituraterre', Revue *Littérature*, no. 3, reprinted in *Autres Ecrits*, Paris, Seuil, 2001

Lacan, J., (1972), 'L'Etourdit', in *Scilicet*, no. 4, Paris, Seuil (1973).

Lacan, J., (1975), 'La Troisième', *Lettres de l'Ecole Freudienne*, no. 16.

Lacan, J., Seminar Book I (1953-1954), *Freud's Papers on Technique* tr. Forrester, J., (Cambridge, Cambridge University Press, 1988).

Lacan, J., Seminar Book II (1954-1955), *The Ego in Freud's Theory and in the Technique of Psychoanalysis*, tr. Tomaselli, S., (Cambridge, Cambridge University Press, 1988).

Lacan, J., Seminar Book IV, 'La relation d'objet'(1956-1957), (Paris, Seuil, 1994)

Lacan, J., Seminar Book V (1956-1957), *Les Formations de L'Inconscient* (Paris, Seuil, 1998).

Lacan, J. Seminar Book VI (1958-1959), *Le Désir et son interprétation*, (unpublished).

Lacan, J., Seminar Book VII (1959-1960), *The Ethics of Psychoanalysis*, tr. Porter, D. (London, Routledge, 1992)

Lacan, J., Seminar Book VIII (1960-1961), *Transference* (Paris, Seuil, 1991)

Lacan, J., Seminar Book IX (1961-1962), *L'identification*(unpublished). Document de travail, E. Gabay, Paris, 1995



Lacan, J., Seminar Book X (1962-1963), *L'angoisse*, (Paris, Seuil, 2004).

Lacan, J., Seminar Book XI (1964), *The Four Fundamental Concepts of Psychoanalysis*, tr. Sheridan, A. (New York, W.W. Norton & Co, 1977).

Lacan, J., Seminar Book XII (1964-1965), *Problèmes Cruciaux pour la Psychanalyse* (unpublished).

Lacan, J., *Ecrits*, (Paris, Seuil, 1966).

Lacan, J., Seminar Book XVI, 1968-1969, *D'un Autre à l'autre*, (Paris, Seuil, 2006).

Lacan, J., Seminar Book XVIII (1970-1971), *D'un discours qui ne serait pas du semblant*, (Paris, Seuil, 2006).

Lacan, J., Seminar Book XXIV, 1976-1977, *L'Insu que sait de l'une-bévue s'aile à mourre*, 1976-1977, (unpublished).

Lagache, D., *Oeuvres*, Vols. I – IV (Paris, PUF, 1977).

Lagache, D., *The Works of Daniel Lagache, Selected Writings*, (London, Karnac Books, 1993).

Laplanche, J., and Pontalis, J.B., *The Language of Psychoanalysis*, (London, Karnac Books, 1988).

Liddell-Scott, *Ancient Greek Dictionary*, (Oxford, Clarendon Press, 1985).

Masson, J.M., *The Complete Letters of Sigmund Freud to Wilhelm Fliess, 1887-1904*, (Cambridge Massachusetts, and London, Harvard University Press, 1985).

Meijer, P.A., *Plotinus on the Good and the One*, (Amsterdam, Gieben, 1992).

Miller, J.A., 'La suture', *Cahiers pour l'analyse*, no. 1-2, Paris, Seuil (1966).

Miller, J.A., A.F. Moebius, The first strip, *Ornicar* 17-18, Paris (1978).

Miller, J.A., 'Les six paradigmes de la jouissance', *La Cause Freudienne*, no. 43, Paris (1999).

Miller, J.A., (1992), 'The Inexistent Seminar', *Psychoanalytical Notebooks*, issue 15, London L.S.N.L.S. (2006).

Mitchell, J., & Rose, J., *Feminine Sexuality, Jacques Lacan & the Ecole Freudienne*, (London, MacMillan, 1982).

Nunberg, H., (1932), *Allgemeine Neurosenlehre auf psychoanalytischer Grundlage* (Berne, tr. Strachey, L., as *General Theory of the Neuroses based on Psychoanalysis*, London, 1955, later as *Principles of Psychoanalysis*).

Jean Piaget, *Le Structuralisme*, Que sais-je, (Paris, PUF, 1968).

Peirce, C., *Collected Papers*, (Cambridge Massachusetts, Harvard University Press, 1960).

Plato IV, *Parmenides*, (Cambridge Massachusetts, Loeb Classical Library, 1977).

Plotinus, *Enneads*, (*Philosophia Antiqua*, Vol. XLIX)

Ragland, E. and Milovanovic, D. (eds), *Lacan: topologically speaking*, (New York, Other Press, 2004).

Ringenbach, A-M., Legroux, E., & Samson, F., 'La Bouteille de Klein', in *L'UNEBEVUE*, Paris (1993).

Romero, R. D., & Manino J. A. 'Comment l'expérience analytique interroge-t-elle le temps?', in *Les Carnets de Psychanalyse*, No 3-4, Paris (1993).

Roudinesco, El., *Jacques Lacan, The Mirror Stage*, (Lecture given in 2000 in the Bibliothèque Nationale de France, Paris, 2001).

Russell, B., 'On Denoting', *Mind*, October (1905).

Short, T., L., 'The development of Peirce's Theory of Signs', *The Cambridge Companion to Peirce*, ed. By Cheryl Misak, Cambridge University Press, 2004, United States, pp. 214-240

Vappereau, J.M., 'Etoffe, Surfaces Topologiques Intrinsèques', *Topologie en Extension*, Fascicule no. 2, Paris (1988).

Viltard, M., Legroux, E., & Toutin-Thélier, C., *L'UNEBEVUE*, no. 7, Supplément, *Negation*, Paris, E.P. E. L, (1995-1996).



## PUBLICATIONS

- ‘The subject in Freud’, article submitted to Journal ‘Subjectivity’, London, 2009  
Under press 2010

## SEMINARS

- ‘The subject in Freud’, public seminar given in CFAR 14 February 2009
- ‘RSI’, Lectures on topology, The London Society of the Lacanian School, March 2006
- ‘Lacan and Topology, a presentation of the cross-cap’, Lectures on topology, The London Society of the Lacanian School, February 2005