

# Design and Development of an Automatic Tool Changer for an Articulated Robot Arm

**H Ambrosio<sup>1</sup> M Karamanoglu<sup>2</sup>**

<sup>1</sup>Designer in Residence, Department of Design Engineering and Mathematics, School of Science and Technology, Middlesex University, London, UK

<sup>2</sup>Head of the Department Design Engineering and Mathematics, School of Science and Technology, Middlesex University, London, UK

Email: h.ambrosio@mdx.ac.uk

**Abstract.** In the creative industries, the length of time between the ideation stage and the making of physical objects is decreasing due to the use of CAD/CAM systems and additive manufacturing. Natural anisotropic materials, such as solid wood can also be transformed using CAD/CAM systems, but only with subtractive processes such as machining with CNC routers. Whilst some 3 axis CNC routing machines are affordable to buy and widely available, more flexible 5 axis routing machines still present themselves as a too big investment for small companies. Small refurbished articulated robots can be a cheaper alternative but they require a light end-effector. This paper presents a new lightweight tool changer that converts a small 3kg payload 6 DOF robot into a robot apprentice able to machine wood and similar soft materials.

## 1. Introduction

In manufacturing, the length of time between the ideation stage and the making of physical objects is decreasing due to the use of CAD/CAM systems. These systems allow small creative industries and workshops to use flexible manufacturing and just-in-time (JIT) production and as a result manufacture products with a price point able to compete with similar products manufactured by larger companies that benefit from economy of scale on pricing. In East London we can find a successful example of a furniture shop that produces solid wood furniture on demand using a CAD/CAM large router and a computer integrated manufacturing system (CIM) [1]. The company, Unto This Last, does not need to stock any products, offers a degree of product customisation to its clients and is able to compete in price with much larger furniture retailers.

Materials suited for fused deposition modelling, such as polymers, a new generation of affordable additive manufacturing machines is providing desktop manufacturing for small creative industries.



The last year also saw the emergence of composite wood plastic compounds being created for additive manufacturing.

Natural anisotropic materials, such as solid wood can also be transformed using CAD/CAM systems, but only with subtractive processes such as machining with CNC routers. Whilst some 3 axis CNC routing machines are affordable to buy and widely available, more flexible 5 axis routing machines are still as a too big investment for small companies. Small refurbished articulated robots can be a cheaper alternative but they require a light end-effector.

Examples of articulated robots used in routing of wood materials are increasingly found in industry [2] (Fig.1).



Figure 1 - Robot at work in Louis Mackall's Breakfast Woodworks cabinet making company [3]

Although articulated robots present less rigidity than CNC machines that can result in inaccurate machining [2], the accuracy is measured in hundreds of a millimetre and therefore suited for wood routing [4]. Articulated robots present increased machining flexibility when compared CNC machines because of the extended work surface by use of tracks [5].

### *1.1 Tool changers for robot material removal operations*

Industry examples used in routing found during this research use large payload robots that borrow motors, spindle and automatic tool changers for the CNC routing industry (Fig.2). Automatic tool holders for CNC routing industry use a drawbar mechanism that clamps tool holders to a spindle. For this type of end effectors the lightest tool changer found weighed 3.5 kg and this is excluding any motor.



Figure 2 – Robot Trim RT-400 with V-taper automatic tool changer [6]

In mechanical process operations requiring less cutting forces than routing, such as deburring and polishing it is possible to find in the market tool changers that change the spindle motor and tool

(Fig.3). This option applied to this specific project of routing would mean a different motor for each routing tool on the tool changer and that would be a costly option.



Figure 3 - Application of robotic arm in deburring of metal and plastic moulded pieces [7]

This paper presents a new lightweight tool changer that converts a repurposed 3kg small payload 6 DOF articulated robot into a robot apprentice able to machine wood and similar soft materials.

## 2. Method

For the design and development of this automatic tool changer presented in this paper the following method was used. A literature review was made in the use of robots in industry to understand the context and review existing patterns in technical specifications of robotic applications similar to the one in this paper. A second literature review examined existing tool holding and tool changing devices, both manual and automatic. This served to provide an image of what is standard in the industry and understand the structure of the mechanism this thesis proposes to develop.

The literature review was followed by the analysis of wood cutting forces (the main material the robot would be asked to work with) and calculations of torque, speed and power parameters to create a clear path for motor research. Following the technical knowledge provided by the above analysis, it was possible to research spindle motor with the best weight, torque speed and price ration to use as motor around which the tool changer was designed.

Following the choice and acquisition of a spindle motor, nine design concepts under the form of sketches were produced, inspired by the research and observation of existing solutions. This phase was followed by a scrutiny of each concept using the weighing chart. A 3D CAD model provided the first detailed outline with the necessary dimensions and visual representation to proceed with the mathematical analysis and finite element analysis of some of the forces that would be affecting the mechanism. A prototype was developed to test the design concept on its ability to engage and clamp a tool holder both when the motor was off and on.

## 3. The robot routing station

### 3.1. The robot

The light tool changer was designed for a Thermo F3 [8] desktop articulated robot manipulator with 6 degrees of freedom (DOF) and maximum payload of 3kg or 29.4N mounted on a 3 meter linear track. This implies that the spindle motor, tool changer, tool holder and end-effector adaptor can have, all together a maximum 3kg in weight. This robot is aimed at the pharmaceutical industry and due to being on the lightest payload of articulated robot arms, it is also on the most affordable price range, making it a great example of robot apprentice for small creative companies manufacturing that don't have a large budget. (Fig. 4)

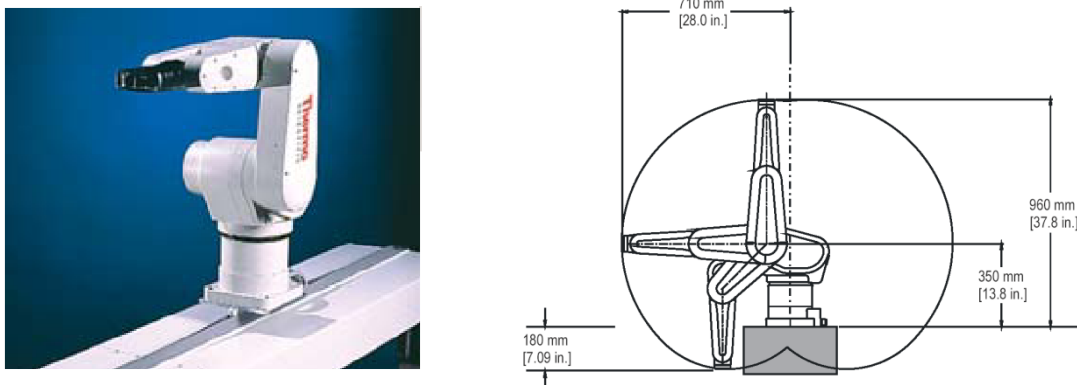

Figure 4 – Thermo F3 robot mounted on track and its work envelope [8]

### 3.2. Motor selection

Motor systems for machining are composed of two parts: a motor and a spindle with the tool. These two parts connect through belts, pulleys and gears or by direct flange. Belt and pulley systems would interfere in the robot's movement. A routing motor was chosen from a selection of electric and pneumatic motors suitable for routing. Hydraulic motor systems were excluded as they are, per definition, heavy and more expensive than pneumatic and electric motors [9]. The chosen motor was the Unimatic direct drive electric motor suitable for wood routing. The Unimatic motor has an output power of 0.35Kw and on-load speed of up 24,100 RPM and an on-load torque of 0.14Nm. Since the maximum weight allowed for the end effector was 3kg, and motor weighs 1.4kg, the automatic tool changer and the robot end of arm adaptor could have a maximum weight of 1.6kg.

## 4. Design of the automatic tool changer

The automatic tool changer design presented is a spring loaded clamping mechanism that needs supplied air pressure only when the end effector collects and returns the tool holder to the tool magazine. Each routing tool would be placed in a tool holder and several tool holders can be stored in a tool magazine. The robot arm would select the adequate tool from the tool magazine, grip the tool, perform the routing task, return tool to tool holder and collect the next tool [1].

The spring loaded mechanism had to hold the weight of the tool holder. Thrust bearings located on the tool holder absorb friction, centrifugal forces and cutting forces that were calculated with mathematical models. The multijaw coupling has to cope with torque generated by cutting forces involved in wood routing.

### 4.1. Self-centring mechanism selection

**4.1.1. Forces involved in wood cutting** Cutting forces in wood were calculated using Eyma [10] simplified formula for calculating wood cutting forces:  $F_c = F_1 \times b \times K_h \times K_m$ , where  $F_1$  is related to direction of cut and wood chip = 44.74 N,  $K_h$  is the moisture coefficient = 0.12,  $b$  is the tool width (diameter) in mm and  $K_m$  is the material coefficient given by the formula:  $K_m = (5.73 \times 10^{-5} \times E_c / SG) + (2.57 \times 10^{-5} \times P_f, I)$ . For the  $K_m$  formula  $P_f, I$  is coefficient of determination of 0.86 between the  $E_c$  or modulus of elasticity in Mpa and and  $SG$  is the specific gravity.

As a reference the cutting forces were calculated (Table1) for high density wood Boco (Bocoa prouacensis Aubl.) [10] as this a hardwood that would produce higher cutting forces than softwood.

<b>Boco (Bocoa prouacensis Aubl.) properties</b>	<b>Boco wood material coefficient</b>	<b>Boco wood cutting forces</b>
F1 = 44.74N Ec = 9940 MPa SG = 1.109	$K_{mboco} = (5.73 \times 10^{-5} \times 9940/1.109) + (2.57 \times 10^{-5} \times 0.86) \rightarrow K_{mboco} = 1.0963 \text{ N}$	$F_{cboco} = 44.74 \times b \times 0.12 \times 1.0963 \rightarrow F_{cboco} = b \times 5.89$ where b is tool width in mm.

Table 1. Boco wood cutting forces [10]

The  $F_{cboco}$  formula was used to calculate the necessary cutting forces for different tool diameters and determine the range of tools the Unimatic motor could cope with to cut Boco hardwood (Table 2)

<b>Tool diameter</b>		<b>Tool radius</b>	<b>Cutting force needed</b>	<b>Torque</b>	<b>Preal using a)</b>	<b>Spindle speed</b>
in	mm	m	N	Nm	kW	RPM
1/4"	6.3500	0.0032	37	0.12	0.230	12000
3/16"	4.7625	0.0024	28	0.07	0.176	16040
1/8"	3.1750	0.0016	19	0.03	0.120	24060

Table 2. Range of tools the Unimatic motor can cope with for cutting Boco hardwood

**4.1.2. Multijaw coupling** The self-centring element was achieved using R3208 stainless steel DIN10718 multi-jaw coupling from Automotion [11]. The multijaw coupling can hold a maximum torque of 7.8Nm which is sufficient to cope with the largest cutting tool the Unimatic motor can cope with. (Table2).

## 5. Design Validation

To test the design a prototype was made. The automatic tool changer prototype weighs 0.345kg and the tool holder weighs 0.176kg.

The prototype was attached to the motor and placed onto a pneumatic rig that has tested the clamping mechanism ability to clamp and release. The clamping mechanism was then loaded with weights up to 120kg

After this first test the mechanism was mounted onto the robot arm (Fig.5) and the robot programmed to perform autonomously the task of collecting a tool from the tool magazine, move away from the tool magazine, return a tool the magazine and collect another tool from the tool magazine.

Finally the design was tested with the motor on without cutting loads at its lowest RPM – 10,000.



Figure 5 – Automatic tool changer with motor and tool holder as the new end-effector for the F3 robot

## 6. Results and discussion of the tool changer design

The automatic tool changer clamping mechanism successfully coped with the 120kg without mechanical deterioration of its components. In addition, the robot was able to easily perform the task of collecting, returning and changing tools meaning the self-centring and the clamping mechanisms are both successful.

Some issues with overheating arisen when turning the routing motor. The overheating is considered to be due to an incorrect choice of thrust bearings or imperfections on the mechanical attachment between bearings and tool holder. The next action to be taken is to develop this design iteration to a point where it has solved a number of performance issues and is ready for prototyping.

In addition, total weight of the tool changer and tool holder at this prototyping stage is 0.521kg. With the motor being 1.4kg it leaves 1.9kg of payload. This means that there is the possibility of attaching the automatic tool changer to a larger and more powerful motor of up to 2.4kg weight. This would mean the possibility of increasing the maximum tool diameter for hardwood cutting and therefore increasing the scope of the design.

## 7. Conclusions and future work

The use of affordable second hand robots in just in time manufacturing with CAD/CAM will allow small companies to compete with larger manufacturers of wood products that benefit from economy of scale. It will also allow these small manufacturers to customise designs and therefore offer added value to the products they sell, creating new business opportunities.

The goal of this work was to design and develop an end-effector with an automatic tool changing mechanism for an articulated robot arm and expand the manufacturing capabilities of small creative businesses.

Through the first part of the validation of this new automatic tool changer mechanism we proved the clamping and self-centring design proposal works well.

Further work is being carried to select and possibly co-design appropriate bearings that will cope with wood routing spindle speeds and the forces generated by the this wood machining process so that this automatic tool changer can be used in industry in the near future.

## References

- [1] Rehg J.A 2003 *Introduction to robotics in CIM systems* (Prentice Hall)
- [2] Hardin W 2006 *Robot CNCs: The Path from Tending to Machining* (Embedded)
- [3] Aitken R 2007 *The Ecstasy of Possibility: An Interview with Louis Mackall* (Fine Homebuilding)
- [4] Papp T and Kovacs Z 2012 *Development of Process Capability Based Fits and Tolerances for the Enhancement of Productivity in the Secondary Wood Processing* International Scientific Conference on Sustainable Development & Ecological Footprint
- [5] Kim C and Chung J.H 2006 *Robust coordination control of a pneumatic deburring tool* J.Robot.Syst. **22**: S1-S13
- [6] 2006 *KMT Cutting Systems launches new tool changer for robotic routers*, Industrial Robot-an International Journal **33** pp 236-237.
- [7] ATI <http://www.ati-ia.com>
- [8] 2004 Thermo Electron Corporation. 2004, CRS F3 Robot System User Guide, UMI-F3-400
- [9] Asfahl C.R. *Robots and manufacturing automation* (Wiley)
- [10] Eyma F, Méausoone P, Martin P. 2004 *Strains and cutting forces involved in the solid wood rotating cutting process* JMater.Process.Technol. **148** issue pp220 – 225
- [11] Automotion <http://www.automotioncomponents.co.uk/en/catalog/rotary/rigid-couplings/rigid-shaft-couplings/r3208>