

Middlesex University Research Repository:

an open access repository of
Middlesex University research

<http://eprints.mdx.ac.uk>

White, A S, 1999.
Mechatronics of systems with undetermined configurations.
Available from Middlesex University's Research Repository.

Copyright:

Middlesex University Research Repository makes the University's research available electronically.

Copyright and moral rights to this thesis/research project are retained by the author and/or other copyright owners. The work is supplied on the understanding that any use for commercial gain is strictly forbidden. A copy may be downloaded for personal, non-commercial, research or study without prior permission and without charge. Any use of the thesis/research project for private study or research must be properly acknowledged with reference to the work's full bibliographic details.

This thesis/research project may not be reproduced in any format or medium, or extensive quotations taken from it, or its content changed in any way, without first obtaining permission in writing from the copyright holder(s).

If you believe that any material held in the repository infringes copyright law, please contact the Repository Team at Middlesex University via the following email address:

eprints@mdx.ac.uk

The item will be removed from the repository while any claim is being investigated.

MECHATRONICS of SYSTEMS

with

**UNDETERMINED
CONFIGURATIONS**

by

AS White MSc, MSc, BSc (Eng.), CEng, FRAS, MRAeS

In partial fulfilment of a PhD by Published Works

At

Middlesex University

1999

Abstract

This work is submitted for the award of a PhD by published works. It deals with some of the efforts of the author over the last ten years in the field of Mechatronics.

Mechatronics is a new area invented by the Japanese in the late 1970's, it consists of a synthesis of computers and electronics to improve mechanical systems. To control any mechanical event three fundamental features must be brought together: the sensors used to observe the process, the control software, including the control algorithm used and thirdly the actuator that provides the stimulus to achieve the end result. Simulation, which plays such an important part in the Mechatronics process, is used in both in continuous and discrete forms. The author has spent some considerable time developing skills in all these areas.

The author was certainly the first at Middlesex to appreciate the new developments in Mechatronics and their significance for manufacturing. The author was one of the first mechanical engineers to recognise the significance of the new transputer chip. This was applied to the LQG optimal control of a cinefilm copying process. A 300% improvement in operating speed was achieved, together with tension control.

To make more efficient use of robots they have to be made both faster and cheaper. The author found extremely low natural frequencies of vibration, ranging from 3 to 25 Hz. This limits the speed of response of existing robots. The vibration data was some of the earliest available in this field, certainly in the UK. Several schemes have been devised to control the flexible robot and maintain the required precision.

Actuator technology is one area where mechatronic systems have been the subject of intense development. At Middlesex we have improved on the Flexator pneumatic muscle actuator, enabling it to be used with a precision of about 2 mm.

New control challenges have been undertaken now in the field of machine tool chatter and the prevention of slip. A variety of novel and traditional control algorithms have been investigated in order to find out the best approach to solve this problem.

This Thesis is dedicated
To
My Mother, Father and Brother

Acknowledgements

I wish to give thanks to the students and colleagues with whom I have worked on the research described in this thesis. To them I owe a considerable debt.

I would also like to thank my Head of School Professor Kubie for his encouragement to submit this work and to my colleague William Maskell for his helpful advice and guidance as mentor.

I have to acknowledge the debt I owe to Mehmet Karamanoglu and Raj Gill for their continued support, without which it would not be possible to achieve so much.

Finally I must thank my wife and daughter for their unstinting encouragement.

Table of Contents

Abstract	2
Dedication	4
Acknowledgements	5
Table of Contents	6
List of Extra Figures	8
List of Symbols	9
List of Submitted Papers	10
Statement about shared contribution	14
Chapter 1 Introduction	15
Chapter 2 Sensors and Actuators	20
Chapter 3 Simulation	34
Chapter 4 Flexible Structure Control	42
Chapter 5 Regenerative and Friction processes	69
Chapter 6 Development of this Research Programme	75
Chapter 7 Discussion and Conclusions	78

References	83
Appendix A Submitted Papers	100
Appendix B Statements of shared authorship	393

List of Extra Figures

Figure Number Number	Title	Page
2.1	Control system schematic	24
2.2	Heave and pitch optical sensor	26
2.3	Rotary sensor	27
2.4	Schematic of the eye-in-hand sensor	29
2.5	Schematic of the dual flexator	30
2.6	ACSL simulation of proportional control of the actuator	31
2.7	ACSL simulation of PID control of the actuator	32
3.1	Roll response of the ship	37
3.2	Effect of winglets on ship roll	37
3.3	Boat toilet used in the FRAC project	39
3.4	Student Bode plot of band pass filter	39
3.5	Student output from the wire drawing simulation	40
4.1	Step response of the film winding system	49
4.2	PDF controller schematic	51
4.3	Optimising simulation results	52
4.4	PDF control of thermal system with time delay	53
4.5	Puma robot modal data	64
4.6	Validation of the optically guided robot	67
4.7	Optically guided robot	67
5.1	Film slip prevention with a neural network controller	72
5.2	Chatter vibration reduction with a PDF controller	75

List of Symbols

Roman

G	Transfer function
k	Gain
k_1, k_2	PDF controller gains
k_D	Differential controller coefficient
k_I	Integral controller coefficient
p	Supply pressure
T	Torque
w	Width of the flexator

Greek

θ	Angle of movement
----------	-------------------

List of Submitted Papers

Presented for the award of PhD by Published Work

In the text these are referred to in square brackets viz. [2]

- 1 AS White. 'An example of optical measurement of vibration', *JSEE*, Vol. 24-2, 21 - 23, (June 1985)
- 2 AS White. 'An optical sensor for angular position measurement of control surfaces in wind tunnel models', *Sensor 85 Conf. Proc.*, 117 - 118, (September 1985)
- 3 AS White & GE Beswick, 'Computer applications of modelling for mechanical engineers', Chapter 18 in *Mathematical modelling, Methodology, Models and Micros*, 223 - 237, Ellis Horwood (1986). ISBN 0-7458-0080-7
- 4 AS White. 'Simulation of a ship's ultimate half roll'. *Marine Simulation Workshop*. Royal Naval College, Greenwich, (Jan. 1988).
- 5 S Adams & AS White. 'A Novel Adaptive Phase Equaliser'. *Proc.Int. Conf. on Computer Applications in Industry*, Egypt, (Feb. 1988).
- 6 SR Ruocco & AS White, 'The Application of ACSL to Robot sensor modelling'. *VI Int. Symp. on Applied Informatics*, Switzerland. (Feb. 1988).
- 7 M Taio, R Seals, R Gill, R Ruocco, AS White. 'Towards Automated Assembly Using Flexible Robotic Assembly Cells, Transputers and Expert Systems'. *IMechE conference on Automated Assembly*. MEP Ref. C86/8, 114-124. (April 1988).
- 8 AS White, S Adams & R Ruocco, 'The use of ACSL and Control-C in teaching electronics', *CAL workshop*, Liverpool Polytechnic. (April 1988).
- 9 AS White, 'Case studies in teaching manufacturing technology', *LOPOCOM forum*, (May 1988).
- 10 JT Parsons, P Warner, AS White, 'CONTROL-C and ACSL used in the teaching of Control Engineering', *IFAC Swansea*, 265 - 271, (July 1988).

- 11 PT Gleeson, Y Wong , AS White, 'Experience of Computer-Aided Testing in Demonstrating Control and Vibration', IFAC Swansea, 245 -251, (July 1988).
- 12 Y Wong, AS White & R Gill. 'Performance measures of a small robot', Proc.5th Irish Manufacturing Conf. IMC-S,475-484. (1988).
- 13 AS White et al. 'On the vibration characteristics of robots'. Proc. 4th Nat. Conf. on Prod. Res., 278-284, Sheffield. (September 1988).
- 14 S Ruocco, R Gill, AS White. 'Sensors for the control of Advanced Manufacturing processes'. IProDE Manufacturing Symposium, Singapore, (December 1988).
- 15 AS White, R Gill & S Ruocco. 'Problems and Prospects for Automated Assembly', IProDE Singapore, (December 1988).
- 16 SR Ruocco & AS White. '3D Robot Vision: the effect of Sensor Intelligence'. Intelligent Sensor Conf., China. (April 1989).
- 17 AS White, 'Simulation of Robot Vibrations', IMA Conf. on Robotics, Loughborough, 553 - 568, Robotics: Applied Mathematics and Computational Aspects,553-568, Clarendon Press, (1993) ISBN 0-19-853649-6
- 18 SR Ruocco & AS White, 'Robot Optical Position Sensor Simulation', European Simulation Conf., Edinburgh, 602-609, (Sept. 1989). ISBN 0-911801-60-X
- 19 AS White, PT Gleeson & Y Wong, 'Robot vibrations', *JSEE*, Vol. 3, No.1, 26-31, (March 1990).
- 20 M Stoker & AS White, 'Control of Winding Processes', Proc. UKSC Conf. on Comp. Simulation, 35-39, (Sept. 1990). ISBN 0-9516509-04
- 21 SD Prior, PR Warner, RGS Platts, KWJ Wright, AS White & JT Parsons, 'Low cost Pneumatic actuators for use in rehabilitation, robotic applications', Proc. Int. Conf. on Rehabilitation Robotics, (June 19 - 20 1991).
- 22 M Stoker & AS White, 'Transputer control of film copying processes'. Proc. Conf. Eurotech Direct '91, (24 July 1991).
- 23 AS White, 'Vibration Control in Robots and other Automation', Proc. 6th Int. Conf. on CAD/CAM, Robotics and Factories of the Future, London, Vol.2, 550 -555, (19-22 August 1991). ISBN 0-874418-02-0

- 24 SD Prior, PR Warner, JT Parsons, AS White & P Oettinger, 'A Hybrid rehabilitation Robotic Arm for the Physically disabled electric wheelchair users', ICOR Keel University, (15 -16 September. 1992).
- 25 J Lewis, R Gill, AS White, 'Heavy Load Robot', *Industrial Robot*, Vol.19, No.4, 28 - 30, (1982).
- 26 AS White, 'Vibration Control in Robots', IEE Colloquium on Active techniques for vibration control -sources, isolation and damping, 2/1 - 2/7, (1992).
- 27 SD Prior, PR Warner, AS White, JT Parsons & R Gill, 'Actuators for rehabilitation robots', *Mechatronics*, Vol.3, No. 3, 285 - 294, (1993).
- 28 M Stoker & AS White, 'Mechatronics Applied to High Speed Motion Picture Film Transport', *Advances In Manufacturing Technology VII*, Proc. 9th Nat. Conf. on Manufacturing Res., Bath, (Sept 1993), ISBN 1-857-90-00-7
- 29 ASWhite, 'Prospects for the active control of chatter vibrations', Proc. CARS and FOF, New Jersey USA, (August 1993).
- 30 SD Prior, AS White, R Gill, JT Parsons & PR Warner, 'A Novel Pneumatic Actuator', Proc. IEEE Int. Conf. on Systems, Man and Cybernetics, 418 - 422, (October 1993).
- 31 AS White, 'Vibration Control in Elastic Manipulators', *J. Computing and Control*, (IEE), 83-88, (April 1994).
- 32 AS White & C Kelly, 'Optimisation of a Control Algorithm using a simulation package', *Microprocessors and Microsystems*.Vol.18, No. 2, 89-94, (March 1994).
- 33 P Ryckaert, B Salaets, M Stoker, AS White, 'Slip Avoidance using a Neural Network Control Algorithm', 10th ISPE/IFAC Conf. on CAD/CAM and factories of the Future CARS & FOF'94, Ottawa, Canada, 602-607, (1994). ISBN 1-895634-06-7
- 34 SD Prior, AS White, 'Measurements and simulation of a pneumatic muscle actuator for a rehabilitation robot.' *Simulation Practice and Theory*, 3, 81-117,1995.
- 35 AS White, J Ebeling and F Ghandban, 'Optimising Pseudo-Derivative Control for an Evaporative Cooling Process', Eurosim '95, Proc. 1995 European Simulation Conf., Vienna, 789-794.

- 36 JS Surdhar, AS White, M Stoker, R Gill and J Korhonen, 'Transputer Implementation of a Fuzzy PD Controller Applied to a Flexible Link Manipulator', Proc. IFAC Workshop on Human-Oriented Design of Advanced Robotics Systems, Vienna, 149-153, (Sept. 1995).

Statement about Shared Contribution

Of the papers submitted in this work, many are by the author alone but 27 are shared with other authors. For all of these the author made a substantial, if not the major contribution. For papers 11, 12, 13, 19, 20, 21, 22, 24, 25, 27, 28, 30, 32, 33, 34, 35, and 36 the work was part of a student PhD or undergraduate programme that I was supervising. The other shared papers were with staff colleagues. Papers 12, 13, 19, 20, 22, 28, 32, 33, and 36 describe work that I initiated.

Appendix B gives statements by the co-authors that have responded to requests for details of the authors' contribution to these papers.

Chapter 1

INTRODUCTION

1.0 WHAT IS MECHATRONICS?

Mechatronics is a new area of engineering, a concept, which was invented by the Japanese in the late 1970's. It consists of a synthesis of computing and electronics to improve mechanical systems. Principally, the use of computer simulation to aid design and sophisticated procedures to control the action of mechanisms is the prime objective of the exercise. To control any mechanical event three fundamental features must be brought together: the sensors used to observe the process, the control software, especially the control algorithm used and thirdly the actuator that provides the stimulus to achieve the end result of the process. My published work concerns investigations into all these areas. Considerable effort has been expended by the Danes (Buur 1989) to identify the fundamental principles of the Japanese methodology without decisive results. The Japanese work with considerable attention to detail as well as defining sensible objectives from the beginning of any design. The key to success was and is the use of the best technology available.

After being strongly influenced by the new approach of Japanese companies I developed a programme of work that looked at the integrated design of manufacturing automation, particularly robots. Robots were, and mostly still are, expensive devices of low mechanical accuracy and precision. To make them more effective and cheaper, Mechatronic techniques can be used to improve their dynamic accuracy, which is limited by vibrations, and reduce the cost of the motors and the fabricated parts by using electronics to stiffen the structure using active vibration control instead of making a mechanically stiffer structure.

1.1 CURRENT STATE-OF-THE-ART

In the USA the Mechatronics concept is relatively new, for example only this year the IEEE started the first US journal of Mechatronics. In this journal early practitioners of the art from Japan, namely Harashima, Tomizuka and Fukuda (1996) refer to Mechatronics as a *postcompetitive technology in the sense that theory follows practice*. They outline eleven technical areas of mechatronic interest. These include:

- 1) Modelling and design
- 2) System integration
- 3) Actuators and sensors
- 4) Intelligent control
- 5) Robotics
- 6) Manufacturing
- 7) Motion control
- 8) Vibration and noise control
- 9) Microdevices and optoelectronic systems
- 10) Automotive systems
- 11) Other applications

They also assert that the Mechatronics industry worldwide is worth about \$110 thousand million or £80 thousand million. At present there is no general theory of Mechatronics. It is not certain that there will ever be one. There is no universally accepted theory of design for example. David Auslander (1996) reviews the requirements for a successful implementation of Mechatronics pointing out the possibilities for disaster.

The originators of the Mechatronic concept, Kyura and Oho from Yaskawa Electric (1996) outline a fundamental division of Mechatronic devices, a procedure not generally used in the West. Their idea is that class 1 mechatronic systems “perform a major portion of system functions, such as machining, motion performance, and operation functions”, their function has been enhanced by the addition of electronic technology. Class 2 mechatronic products “are traditionally wholly mechanical

products that have retained their external configuration and primary functions, but have changed their internal configuration with the introduction of electronic technology". Class 3 products are those, which retained their mechanical functions only, a good example being a digital watch. The Japanese make great play of these subdivisions; however in the West they do not provide much light. More important are the design issues identified by Kyura and Oho. These include:

- * Software deficiencies where inclusion of control function and mechanisms are desired.
- * Lack of general detail design parameters from overall performance simulation
- * The control function is difficult to choose from a requirement on the precision
- * No way at present to choose sensor and actuator data from system requirements

They also acknowledge the movement to use PC's as the controlling computer in Mechatronic products.

Rolf Isermann (1996) discusses the modelling and control of mechatronic products. He describes the critical design features to allow precision control in the presence of considerable friction. His is a wide-ranging survey of the current state-of-the-art including the use of bus systems, supervision and fault detection. His special point is to plead for real time simulation of mechatronic systems.

Youcef-Toumi of MIT (1996) describes the use of Bond graphs for analysing mechanical components of the mechatronic system. He goes on to describe the control algorithms in use at MIT, particularly on their direct drive robots. The principal conclusion from his paper is that the more accurate the system requirement, the more complex the control system needs to be.

The ultimate proof of the mechatronics concept is given by Ohishi, Miyazaka and Nakamura (1996) who have shown that the mechanical and electrical limitations of a velocity servodrive using an optical encoder sensor can be overcome by clever use of observers.

1.2 SCOPE OF THIS THESIS

The purpose of this thesis is to show the contribution the author has made to the field of Mechatronics and to contrast his work with that of the current best practitioners. Since this PhD is to be judged on the basis of published work a central theme will be outlined and the papers grouped into that theme.

Systems can be grouped into those, which have characteristics that are known in good detail and do not change with time or space and those which do change with time, or with position. Two types of systems examined here, which fit the second category, are robots, and systems, which include friction. Robots have members or links that have a variety of positions associated with their programming. They also have members that have considerable elasticity. For a given programme the elastic deformation will depend on the precise loading of the arm at that time. In the case of systems where friction is the dominating dynamic feature the precise movement is uncertain because the exact time of movement is not known in advance. These systems were very difficult or even impossible to control before electronics and software made the problem more tractable. In the Mechatronic approach all these problems have a certain similarity that will be drawn out in the succeeding pages.

Chapter 1 gives an overview of current Mechatronics practice with the attention concentrated on the issues that are the subject of this thesis. Mechatronics as already indicated includes the application of sensors and actuators, these are covered in Chapter 2 which gives an indication of the current state-of-the-art. This is followed by an analysis of the contribution given in the authors published work. Development of all Mechatronic systems is an integrated function and the development of sensors and actuators cannot be divorced from the model devised to design and operate them. This requires a suitable simulation of the response of the model to all possible stimuli that the device is exposed to being undertaken. In Chapter 3 this simulation environment is examined. The implications for the design process are carefully considered in this section.

These features are most important when the control of flexible mechanical systems is dealt with in the next chapter. This is where the bulk of the author's works is concentrated. It is also the area where most other researchers in the field of Mechatronics are concentrating their work at present. As already indicated the uncertain nature of the system can be allowed for if a rigorous programme of testing can be undertaken but in many systems this is not possible since the varying operating conditions are not known in advance. This is referred to the problem of robustness. The controller can be designed to allow for the range of possible circumstances.

The choice of controller to effect this result is now quite wide. As in many other fields of human activity fashion plays an important role. Up to five years ago the favourite method was an LQG optimal controller, but now Fuzzy or Neural network controllers would be tried first. This is basically because they are much simpler to design and implement. However they do not always work as well as other controllers and a trial choice is made using simulation. In Chapter 4 a review of control methods is given together with a critique of techniques used in flexible robotic arm control. The author's work is then critically examined with respect to these other workers.

Chapter 5 continues with the analysis of undetermined systems, this time with those governed by friction. A critique of the problems is given with a review of current methods used. These are then compared to those used by the author. Chapter 6 contains a discussion relating to the development of this work in the University and Chapter 7 contains a discussion and some conclusions about the work described here originated by the author. The thesis is terminated by the copies of published work submitted here.

Chapter 2

SENSORS and ACTUATORS

2.0 INTRODUCTION

Sensors and actuators are two important parts of any engineering system (fig 2.1). If the system properties cannot be sensed correctly then an observer can be designed to give the necessary information provided a good model of the system can be created. However this procedure gives poorer control than that available if the information comes from sensors directly (Doyle and Stein 1981).

There can be no system control at all if the actuator is not present. However even if an actuator of insufficient bandwidth is available then some form of control can be achieved. It is usually the case that the actuator is not “good enough” in all cases. It may be torque-limited or not respond with sufficient amplitude at high frequencies. As in all design, choosing an actuator is a compromise between performance and price. As Mechatronics engineers we have to examine the implications of this dichotomy. In a field where we are trying to achieve tasks that have not been possible before a substantial amount of research has been undertaken into new types of actuators including the development of actuators which at present have a limited application, but are potentially very useful in other areas. Many of these are applications of pneumatics, which are simple and cheap. Mechatronic principles can be used to overcome the limitations of the medium, that of non-linearity and hysteresis. This is the area that has occupied the team at Middlesex.

2.1 REVIEW of CURRENT DEVELOPMENTS

The major industrial nations are all investing in developments in this field because the potential world sales are enormous, potentially of the order of several thousand million pounds a year. All industrial and commercial sales are likely to use the new

sensors and actuators. This is without the contribution of new applications. In the sensing field new areas of investigation include chemical and surface data, measuring position more cheaply and faster as well as greater accuracy. Britain has a significant slice of the world market! It is currently investing heavily in research into new sensors but not into new actuators. In Japan for example new motor designs appear monthly, they are the biggest investors in research on new pneumatic actuators and all their robotic teams have some research into new types of actuator.

2.1.1 Sensors

The field of sensors is vast; over 200 papers per year are published in this area alone. There are three relevant fields to discuss.

- * Position sensing, linear and angular
- * Shape sensing

Modern displacement measurement includes laser velocity transducers (1989). These devices can now cope with multi-channel measurements over several metres range. They can be used to detect velocities of the order of 0-0.2 m/s. The frequency range can be up to 20 kHz. At the lower frequency of 0.1 Hz a velocity of 10 nm/s can be measured.

Not many angular displacement sensors are described in the literature, but of the free floating designs we would include miniature gyros. These are about 20 mm in diameter and 50 mm long but cost over £2000. Other sensors for this role would probably be angular accelerometers, these are about 20 mm cube but cost several hundred pounds.

Eye-in-hand sensors have been used by a number of authors including Whitehead et al. (1986), Orrock et al. (1986), Baird and Lurie (1986), Loughlin and Morris (1986) and Agrawal and Epstein (1986). They all have some features in common with the work described by Ruocco and White but do not extend it as far.

Costa-Maniere et al. (1995) of Carnegie Mellon used an eye-in-hand device to contour follow unknown objects.

Jardim and Absi-Alfaro (1996) have designed an eye-in-hand system that includes a CCD camera and a small laser diode rangefinder. It can also be used for edge identification and following objects.

Luo (1996) reviews the overall impact of sensors in the field of Mechatronics.

He divides sensors for mechatronic applications into the following categories:

- a) Inductive proximity sensors
- b) Capacitive proximity sensors
- c) Photoelectric proximity sensors
- d) Ultrasonic proximity sensors
- e) Linear Variable differential transformer displacement sensors
- f) Solid-state sensors
- g) Fibre-optic sensors
- h) Force-torque sensors and load cells

He also discusses highly redundant sensors and multi-sensor fusion and the part biological research has to play in providing information on the techniques used by animals. The advantages which microsensors have due to their small size and ability to contain functions such as self-checking are listed by Luo. He also poses the problems that such sensors have due to their exposure to the environment. Due to their small size and capabilities new applications are to be found in Medical and Biological Control situations.

Kyura and Oho (1996) include a biting critique of current sensor qualities for mechatronic applications. They state that inadequacies of sensors include:

- * Lack of compactness;
- * Reliability;
- * Durability in harsh environments;

- * Response for real time control;
- * Component accessibility;
- * Data and signal processing;
- * Communication between sensor and the network;
- * Price.

There are sensors that already meet the requirements and it is expected that nano-technology will deliver substantial improvements.

2.1.2 Actuators

Actuators are definitely restricted in applications by their size and force/torque capacity. They tend to fall into a small number of classes:

- 1) Pneumatic
- 2) Hydraulic
- 3) Electric
- 4) Chemical

Ishihara, Arai and Fukuda (1996) describe actuators that are suitable for micro mechatronics. This type of actuator can be produced by using electromagnetic, electrostatic, piezoelectric and optical principles. Areas of application include micro catheter in the medical field and inkjet printer in the industrial field. The energy supply for these devices is usually a chemical silver oxide, lithium or nickel-cadmium batteries. These devices are often manufactured using conventional electronic fabrication techniques. Response times of these small actuators are of the order of 1 s to 1 μ s. Miniature motors with shaft sizes as small as 150 μ m have been constructed while electrostatic grippers of 10 mm length are typical. Some of the actuators described can be scaled up to larger sizes but others are limited by the fundamental design.

Pneumatic actuators are very useful in that they exhibit compliance that is not the case in other more well controlled actuators. Shimizu et al. (1995) describe a pneumatic rubber actuator for rotary joints. Static characteristics were presented. The control was executed using an adaptive gain method. Hamerlain (1995) describes a “new” actuator using antagonistic pneumatic muscles. These are controlled using a variable structure controller and a PID controller. Both step and tracking responses appear to be satisfactory. Similarly Medrano-Cerda et al. (1995) use adaptive pole placement for their controller. Tang and Walker (1995) also used a variable structure controller to achieve adequate control of a pneumatic actuator.

A McKibben ‘Rubbertuator’ was used by Tondu et al. (1995) to actuate a SCARA type robot and Chou and Hannaford (1996) describe an analysis of the McKibben pneumatic artificial muscles. Their analysis is similar to that performed by Prior and White [34]. The results are broadly in line with that work despite the different construction.

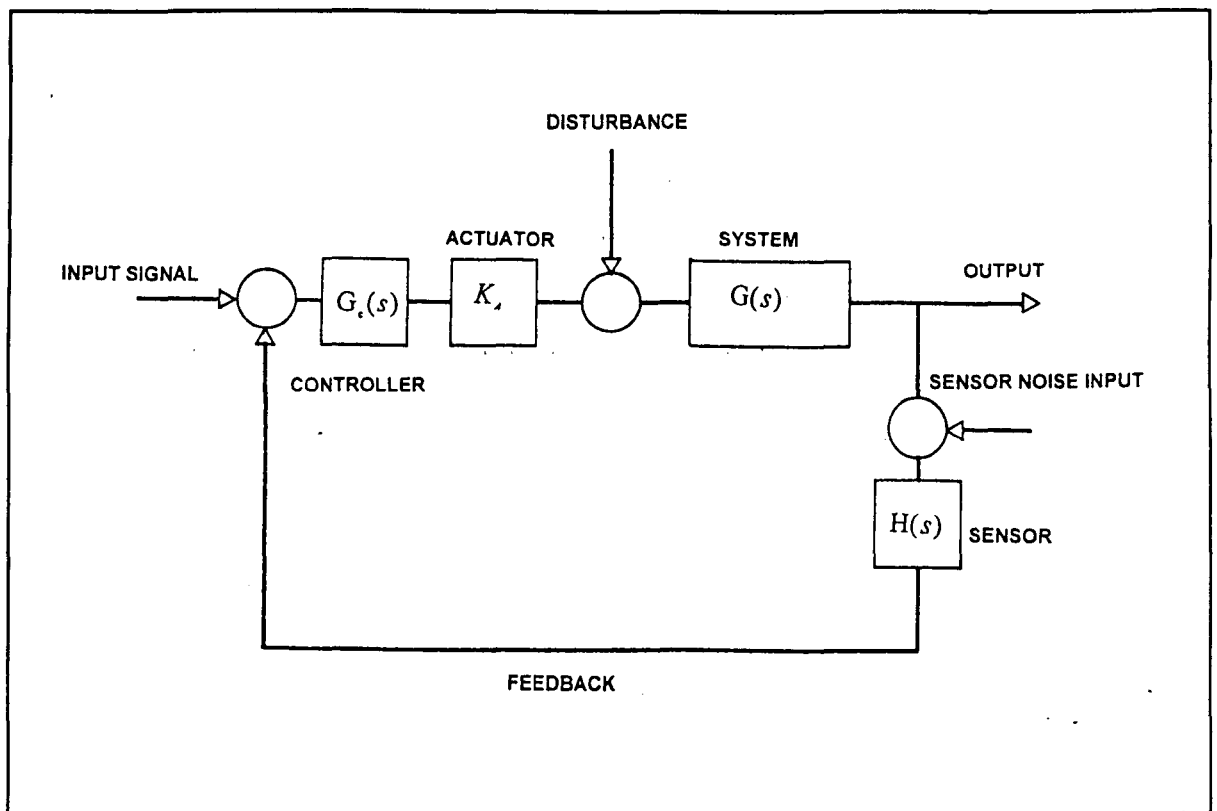

Figure 2.1 Control System Schematic

2.3 RESEARCH at MIDDLESEX

2.3.1 Aircraft and ship model motion sensors

As part of a computer control system [1], a simple optical sensor was devised, originally, to measure the motion of an aircraft model in a wind tunnel. Later it was used to measure the roll and heave of a ship model. It used a laser beam split into two paths and directed through a pair of graded filters mounted on the model (fig 2.2). The tapered slots were mounted on the model and the photocells mounted on the opposite wall to the laser. Only small inertial (4%) and vibration effects on the model were sustained. Motions up to 50 mm in amplitude and 20° in pitch could be measured. The disadvantages of the system were that the random motion of the aircraft model due to tunnel turbulence produced greater motions than the available range of the device, in the ship model it sometimes did not remain in the same plane due to the effects of a close walled basin. The original filter used a graded optical filter that was non-linear in operation. This meant that electronic filters could not be used to filter out the random motion. A linear slot version was developed for the ship model that was more satisfactory. The principle has been used on other sensor applications used by the author [2]; these use a novel variation to measure rotary motions. The sensor, linear in its calibration to within 3% was produced on a Computer Numerically Controlled wire-eroding machine. This sensor has been used to measure rotation of a satellite model (fig 2.3). In this case a flexible satellite model is to be controlled. The rotary optical sensors measure the rotation at three bays on the satellite.

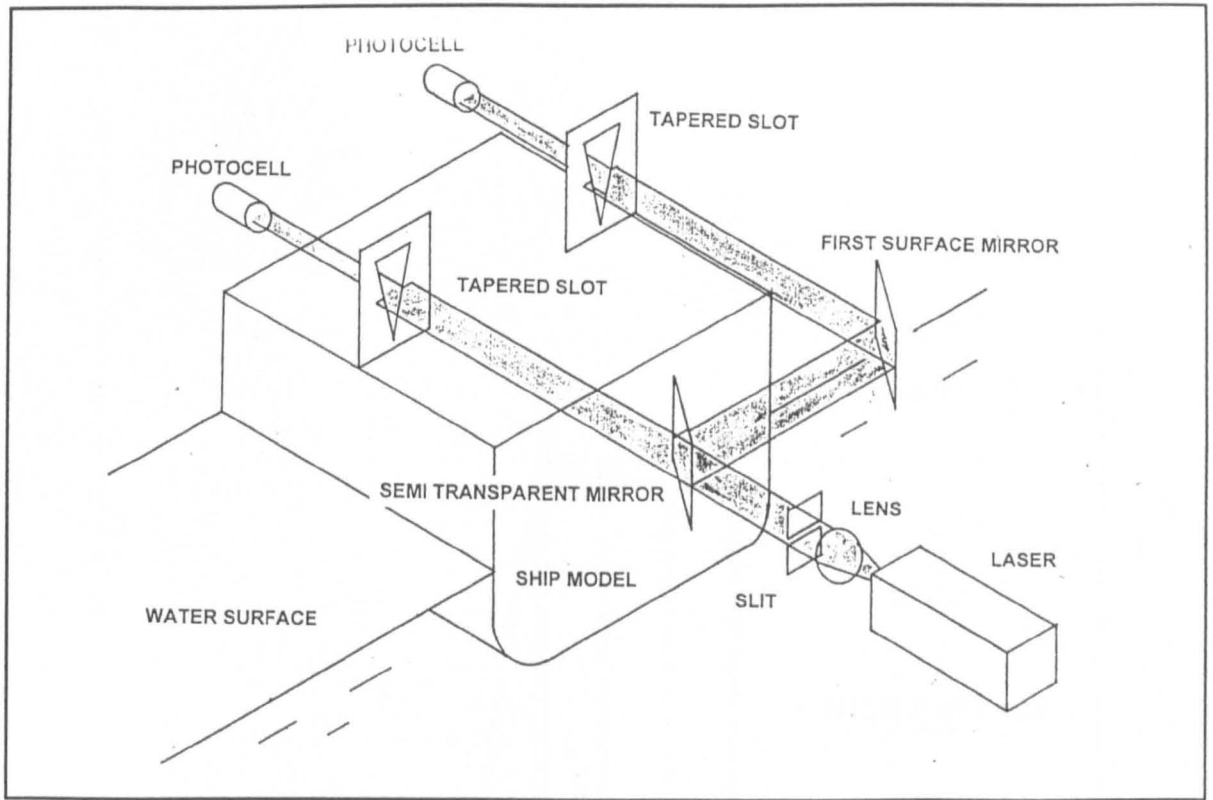

Figure 2.2 Heave and Pitch Optical Sensor

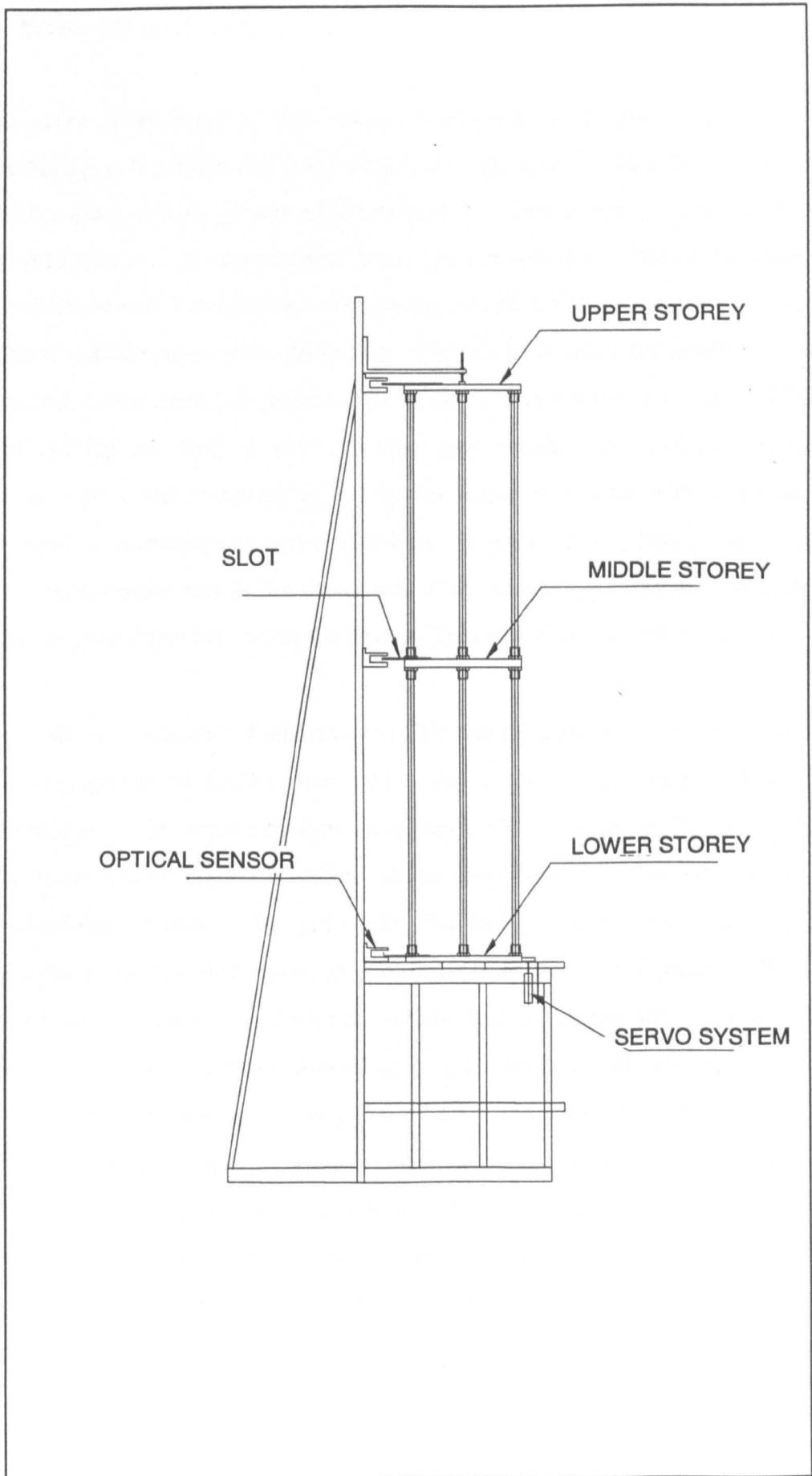

Figure 2.3 Satellite rig using the rotary sensor

2.3.2 Robot Vision Sensor

At the same time research was being undertaken to produce a sensor fusion manufacturing cell, which was to be largely autonomous [7, 14&15]. In any multi-sensory feedback system greater information is available in vision systems. We give in [14] a breakdown of vision sensor types used in robotics. One of the criteria for greater effectiveness in assembly is knowledge of the distances involved between the robot hand and the object to be picked up. For this to be achieved intelligent sensors are required. Since more information can be gained from vision Ruocco & White [6, 14, 16&18] fig 2.4 devised such an intelligent sensor. At that time it had an advantage over a video camera in that it was faster as it dealt with less data. This sensor used a statistical adaptive algorithm to gain its sensitivity. The author's principal contribution was in the simulation of the sensor's performance and devising mechanical procedures for testing the device. This was also reported in [21].

The basic device consisted of an array of LEDs and photocells, which are arranged, in a guard ring around the LED source, which sent out a scanned beam set towards the unknown object. The schematic block diagram is shown in [18 fig 3]. Data is gained using a model driven algorithm, based on the object that is suspected to be present. The methodology is indicated in [16 fig 5]. For each frame of values, range gradients are calculated and the reflectance is estimated from the optical model. These are compared with estimated reflectance values and a confidence limit calculated. Alteration of the scan is made according to the statistical data computations. The author's contribution was in devising the ACSL simulation of the highly non-linear and adaptive optical coupling model. This was crucial in altering the design. This model is similar to that of Jardim and Absi-Alfaro but is actually more sophisticated. Costa-Maniere et al. have shown how useful this type of device can be in industrial applications, allowing intricate contour detection to be effected in a relatively shorter time than using a contact probe.

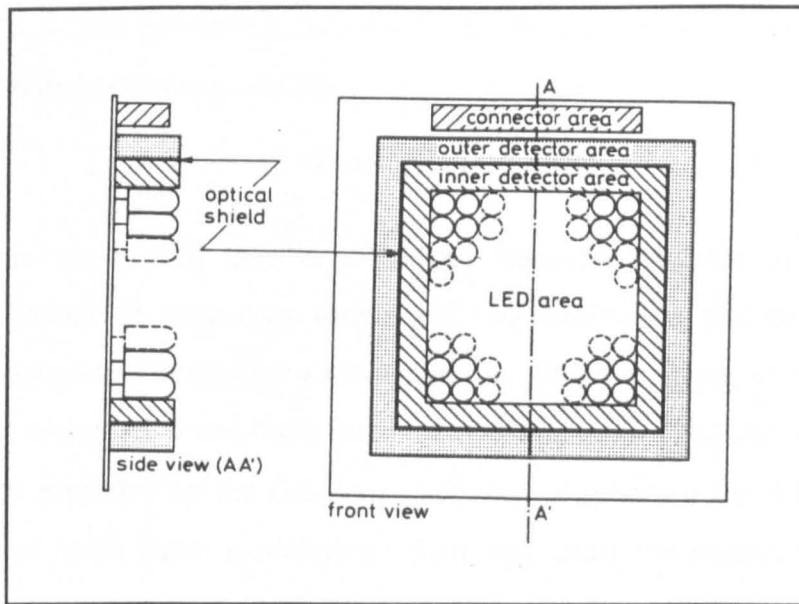

Figure 2.4 Schematic of the Eye-in-Hand Sensor

2.3.3 Pneumatic Actuator

A new actuator, the flexator, has been investigated by PhD student S. Prior [21, 24, 27, 30 & 34], based on the muscle that drives the Splitting Image puppets. Rival devices such as the rubbertuator operate as linear travel actuators. A flexible rotary actuator is formed by cutting a length of fire hose, bending it and the ends are then sealed. We normally operate it in the dual antagonistic mode (fig 2.5) which yields greater linearity and smaller hysteresis. When pressure is applied the flexator is pressurised, its volume increases and a webbing strap attached to the tube and wrapped around the muscle produces the torque[34(fig 1)]. The flexator operates at pressures up to 3.5 bar. The advantage that this muscle has over conventional actuators is low cost and high power-to-weight ratio. It is limited however by its non-linear behaviour. These papers represent differing aspects of the work especially the static behaviour of the actuator, the energy storage and the dynamic performance. The overall static energy balance is such that the maximum thermal efficiency is just over 50%. The stiffness of the dual flexator used gave a linear curve against displacement. This enables the device to be powerful and compliant, qualities desirable in a medium for use with disabled users. From non-dimensional analysis a relationship between

torque, T , the supply pressure p and the width of the muscle w and the angular displacement θ in degrees is given by:

$$\frac{T}{pw^3} = 0.12 - 0.016\theta \quad 2.1$$

It is shown in paper [30] that in the larger sizes the flexator outperforms all conventional pneumatic devices on torque and torque to weight and on price! . This muscle was applied to a design for a robotic arm to aid quadriplegic wheelchair users. The robot arm designed to use these muscles was a modified SCARA type with the rotary function provided by the flexators. Air was admitted to the solenoid valves using a form of pulse width modulation. This was under the control of an INTEL 8051 microcontroller. Simple potentiometers were used for the joint sensors. The simulation model described in [34] shows how the control pressure system can be driven to overcome a large part of the non-linear behaviour. Good agreement was obtained between the measurements and the simulation model. Subsequent simulation, figures 2.6 and 2.7, has shown the effects of simple proportional control being replaced with PID control. It can be seen that the overall response without altering the structure is much faster and has reduced steady state error.

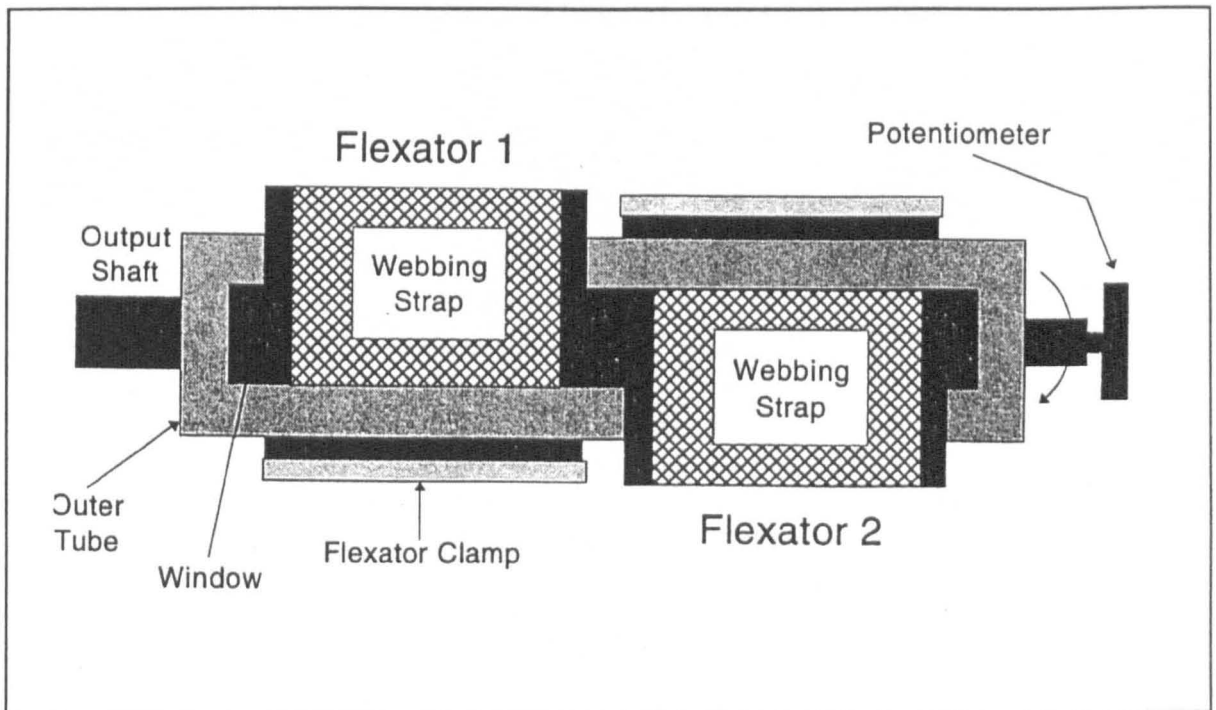

Figure 2.5 Schematic of Dual Flexator

Other workers have experimented with the same actuator and are producing similar results (Tillett 1993). The work of Shimizu and Hammerlain (1995) is also broadly equivalent.

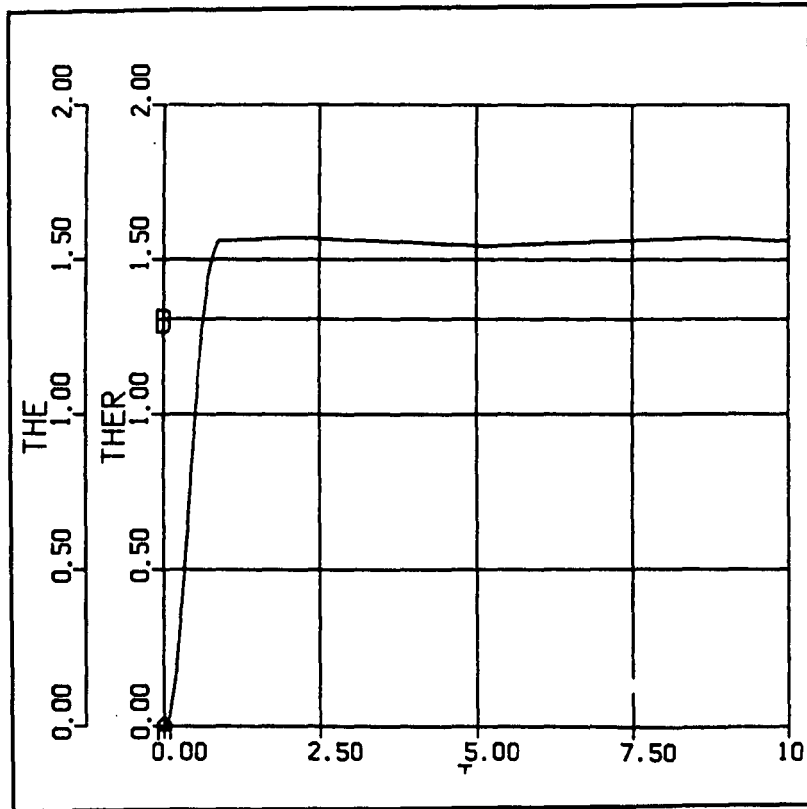

Figure 2.6 ACSL Simulation Proportional Control

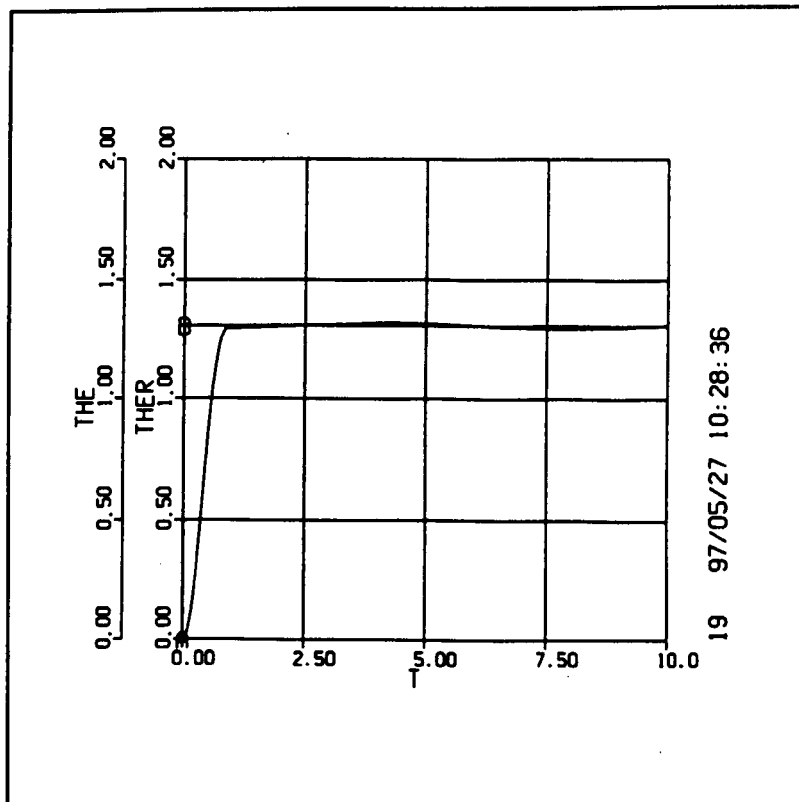

Figure 2.7 ACSL Simulation PID Control

2.4 SUMMARY

The aircraft model sensors devised constitute a viable solution where low cost and reasonable resolution (0.05 mm) are required. They are restricted in frequency response by the structure upon which they are mounted rather than by their own limitations. Their frequency response could be extended to several hundred hertz. However because they are displacement sensors they do respond to noise at a more significant level at low frequencies, which can be a problem, since this is exactly where the rigid body response is. In a similar sense to laser Doppler equipment they can be accessed remotely. The order of accuracy is however much less, but so is the price. The robot vision sensor, although in no way fully developed, is quite equivalent to or in advance of contemporary research. It will eventually lose out to miniaturised TV cameras as the price, size and difficulty in processing data become less of a problem. However as a more sophisticated range finder it may still find a role.

Compared with commercially available actuators the dual flexator is cheaper, produces as much torque and is lighter. The method of pulse-width control is adequate but could be improved upon if a cheap proportional valve were available. Compared with other researchers in the field the work is as far advanced as any. Compared with the rubbertuator the device is considerably superior.

Chapter 3

SIMULATION

3.0 INTRODUCTION

Over the last fourteen years digital simulation has become an industry in itself. There are several continuous simulation packages available besides ACSL. The most significant development is the availability of icon front-end interfaces to equation solvers. The biggest rival to ACSL is perhaps the SIMULINK package that runs with MATLAB. ACSL now has its own similar graphical front end. Perhaps the greatest change is the professional development of the simulation community, with several specialist journals concerned with the theoretical development of simulation. The state-of-the-art is now such that excellent textbooks, (Matko et al. 1992 and Bennett 1995) have represented current practice.

Considerable effort has been placed over the last ten years into the comparison of solutions for benchmark problems using different packages. The development of CACSD software has been mirrored by the rise of the discrete solver packages for manufacturing simulation. These include SIMAN/CINEMA, HOCUS and WITNESS. The author first used SIMAN in the early 1980's but it proved to be a difficult package to teach to students. We have now moved to use WITNESS, a much friendlier package.

3.1 SIMULATION in DESIGN

An approach to the integration of computer techniques to the design process was initiated in the new Finneston degree at Middlesex. This programme [3] used a comprehensive approach to the use of simulation to solve engineering problems, which was at the time in advance of many US degree programmes. It exploited the

use of computer simulation and finite element analysis to an extent not widely used at that time. The finite element work was due to G. Beswick whereas the author formulated the continuous simulation. The subject matter to which the students were exposed included numerical analysis and Computer Aided Drafting as well as analysis. Much of the time was spent in pointing out the difficulties that could be encountered and how to deal with them. The approach as taught dealt with design as an optimised simulation procedure. The basis of this procedure is that of validation and feedback. In any simulation the model must first be established by analysis and judgement. This is refined by thought experiments until the model is considered good enough to test. A simulation model is derived and the model programmed. Verification of the computer code is checked and the digital experiments performed according to a previously defined set of criteria. The results are validated against some external features of the model. When and only when this has been achieved can predictions of performance be obtained from the simulation. Hence simulation and the design process are inextricably linked. Besides purely mechanical design we can use the same procedures for any Mechatronic devices.

Simulation of electronic circuits is possible with several pieces of software, but ACSL has advantages in flexibility over the most commonly used, which is SPICE. Collaboration with two colleagues on their PhD material was undertaken[5 & 6]. One of these was already described in Chapter 2, but the other was concerned with a novel adaptive phase equaliser circuit for tape recording. While the original electronics was due to the co-authors this author produced the simulation work. The use of ACSL on such adaptive circuits had not been attempted before in the UK. The phase equaliser circuit had been design and tested at King's College but was not producing results that could be explained. During the modelling phase it was found that the way the electronics was thought to behave did not account for high frequency coupling of several components. This was corrected when the ACSL simulation model was written. Validation with the experiments was then achieved.

3.2 MECHATRONICS, SHIPS AND SIMULATION

Simulation plays an important part in the Mechatronics process, both in continuous and discrete forms. The author has spent some considerable time developing skills in this area.

Mechatronics can be applied to ships [6] as readily as to any other system. As a result of the shipping capsizes of the late 1980's it was decided to see if any simple or Mechatronic solution was possible. To validate the simulation a capsize problem from an earlier investigation was examined. Capsize of a vessel due to stern quartering waves is a system that requires a model that is described by two coupled non-linear differential equations. The simulation was produced for the first time at Middlesex on a PC rather than on the mainframe. Time of execution was of the order of a few minutes. This allowed an extensive investigation to be made before any model was built. At the same time an analogue computer model was used to check other Danish workers' solutions. For the analogue computers a very good match was obtained. The digital simulation was somewhat different, predicting capsize at a lower wave height (fig 3.1). This gives good agreement to model tests performed by several project students. This disagreement between digital and analogue simulation is quite common. The analogue machine is only accurate to within 0.1% in each component, so that when several components are put in series the overall accuracy drops to about 5%. One solution examined, the addition of winglets, would have prevented several recent capsizes if installed (fig 3.2). Active control of ship stabilisation has been shown to be successful in model tests. Subsequent research by the author has examined the effect of using a manoeuvrable propeller for this task. Other workers, trying to prevent the sinkings similar to that of the Free Enterprise, have tried several passive installations for preventing capsize. This would **not** prevent capsize due to quartering seas that the author's method would. This is the subject of a patent application.

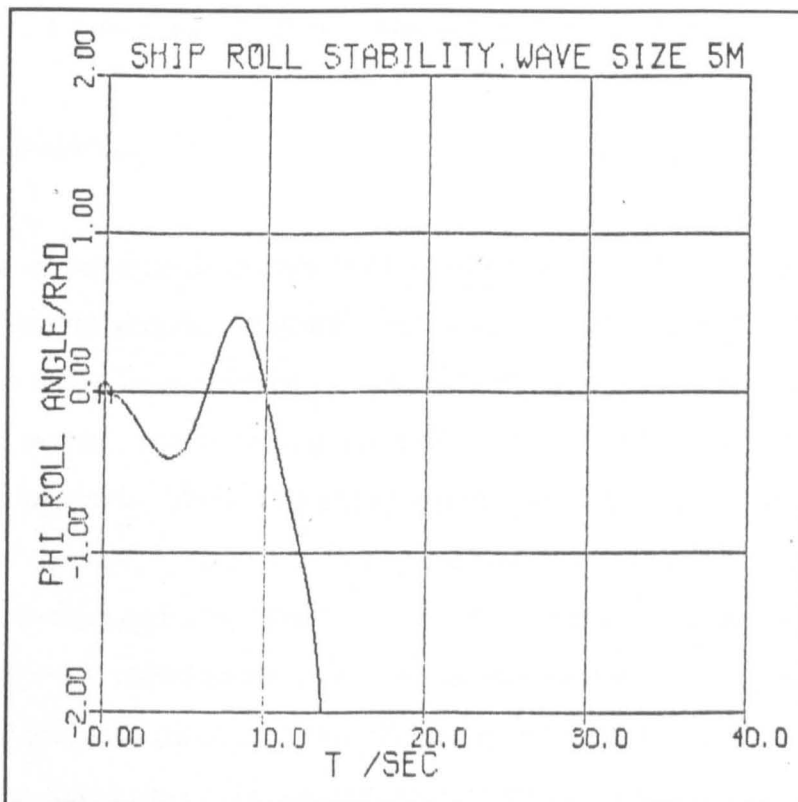

Figure 3.1 Roll Response of Ship

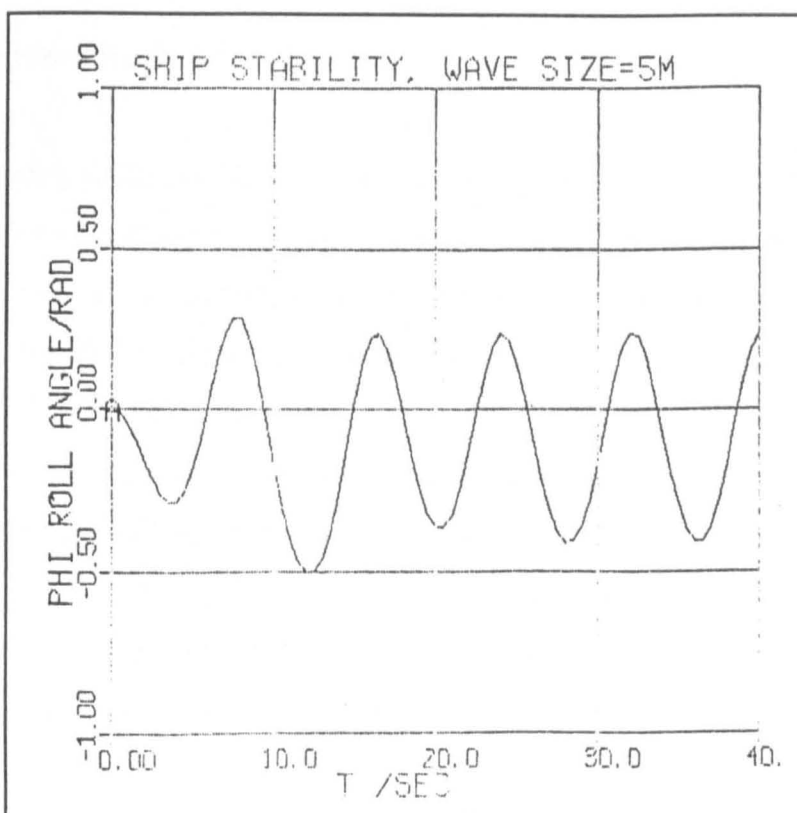

Figure 3.2 Effect of Winglets

3.3 SIMULATION, TEACHING AND MANUFACTURING

3.3.1 Manufacturing

A key feature of the modern manufacturing process is the extent to which the whole procedure can be integrated. The robotics group at Middlesex looked at the way a boat toilet (fig 3.3) could be assembled [7, 15] with the most favourable developments, including the use of expert systems for the recognition of parts and the possible layouts of the assembly robots. The entire layout, part ordering and assembly details were made by the author with only minor contributions by the other authors to the implementation procedures. Although not put into practice because of the probable costs it did allow the manufacturer to reconsider the manual assembly and gain some efficiencies. Major costs associated with the project were the robots themselves. Other costs including development of sophisticated software proved to be far less than expected. For manufacturers to use such intelligent manufacturing cells, robot costs had to be reduced.

3.3.2 Electronic Circuit Analysis

Programmes using ACSL and CONTROL-C, a computer aided control system design package, for electrical filters and more complex controllers developed by the author in conjunction with Stanford University, were used by S. Adams and R. Ruocco to teach their M.Sc. in Applied Computing students [8] in the Electronics School. The Bode plot from a student's work is shown in fig 3.4. Similarly results of some consultancy work to control the extrusion of material such as metal bars or plastic tubes, was used to illustrate teaching on these MSc courses [9] (fig 3.5). The next two papers [10 & 11] show that these techniques could be also used to teach Computer Integrated Engineering to other students at MSc and higher degree level.

Students were not instructed in any more than bare details of how to operate the packages but were taught about the techniques of simulation, especially verification and validation. This work was highly interactive with the students often taking the simulation to regions not envisaged by the tutors. As such it was extremely popular,

and somewhat in advance of normal practice in the early 1980's. Now of course there are much more student friendly packages for this type of work including Working Model and Mathcad.

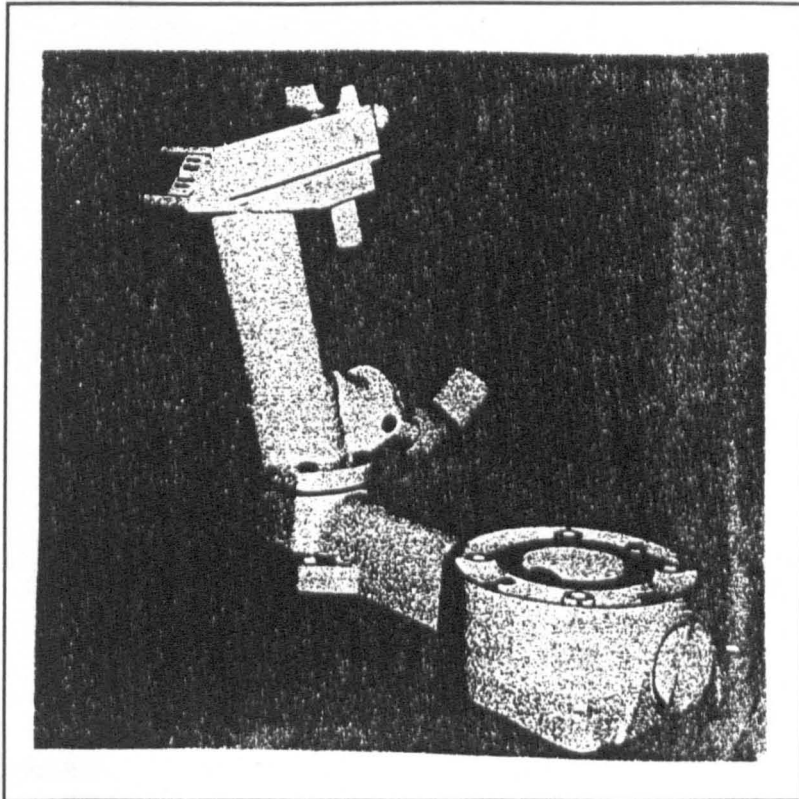

Figure 3.3 Boat toilet

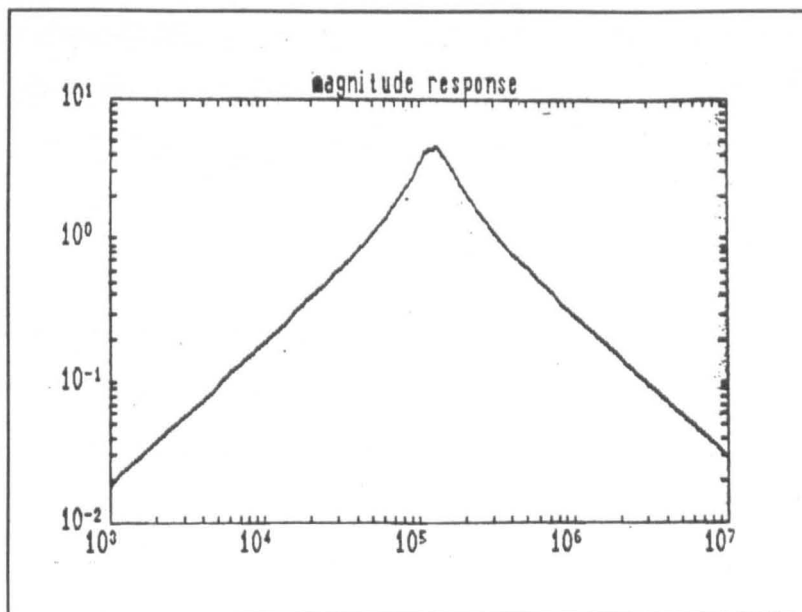

Figure 3.4 Student Bode plot of band pass filter

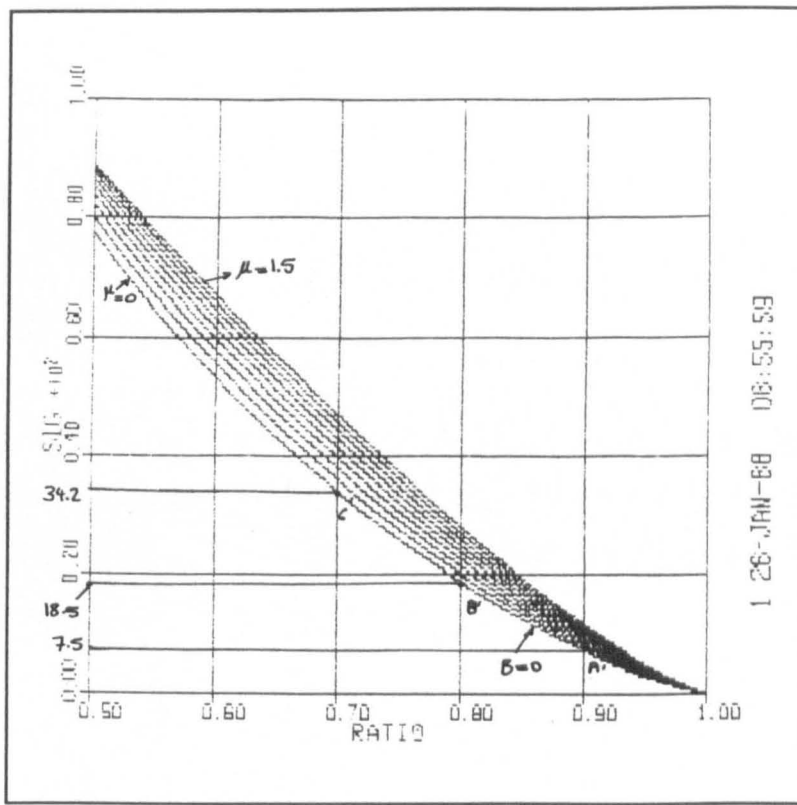

Figure 3.5 Student output of wire drawing simulation

3.4 SUMMARY

Using the simulation approach to design allowed the students to perceive the potential benefits of the methodology as well as its handicaps well away from any subject specific analysis. This meant that many of the objectives of a Computer Aided Engineering degree could be gained without departing radically from a Mechanical degree programme.

In showing the power of a mechatronics approach to regaining ship stability the author has helped to show that any problem that was previously intractable can now be tackled with promise of success. Although naval architects are only now beginning to consider control-configured ships, submarines have been treated this way for some time. Most of this material is classified. This example is another system where the configuration changes in a way, which is or was not predicted by the designer and we require a control system to cope with the situation. The size of the wave is not known

in advance nor is the exact response of the ship in roll since it depends on the previous unknown time history because it is a non-linear system.

The power of digital simulation in solving quickly problems to do with manufacturing and allowing the possibility of creating autonomous manufacturing cells is clearly shown here.

Use of these powerful simulation packages as teaching aids has proved to be the key to the way to introduce students to the mechatronics methodology. The rapidity of solution and the range of complex real world problems gives the students' confidence in their ability to make progress.

Chapter 4

FLEXIBLE STRUCTURE CONTROL

4.0 INTRODUCTION

Control systems are almost 2000 years old. Most modern applications date from the seventeenth century, with a great flowering in the twentieth century. By the time of the start of the Second World War the basis for classical control theory was in place with Proportional, Integral and Derivative (PID) controllers in use as was velocity feedback. During the Second World War these were applied to radar, guns and the direction control of aircraft and missiles. In the 1960's the advent of the space programme led to the state-space method becoming the choice of representation.

Optimal control theory (Athans 1966) was nearly fully developed by the end of the decade. When applied to even fairly simple systems it became clear that Optimal Control did not work as well as conventional control. Very few industrial examples were forthcoming but the theory continued to be improved over the next twenty years until today the theory is proven to be an excellent control strategy.

Over 10000 papers have been published in this subject area so that we can only attempt to highlight the most significant developments.

4.1 CONTROL ALGORITHMS

In order to control a mechanical or other system a control system must be designed to cope with the range of known inputs to the system. Analysis is performed to produce a model that can adequately represent the system. This is usually the most difficult task, while the choice of control algorithm is fairly straightforward. However there are now many choices that can be made. Almost all of these include some form of negative feedback, which is the key element of a mechatronic system. Controllers that use classical integro-differential models to represent the system are almost all related

to the Proportional(P), Integral (I) and Derivative (D) controllers developed before the Second World War. Controllers, that use the state-space set of differential equations, are usually based on a least squares weighted state and control input optimal model. Newer methods such as Fuzzy and neural network controllers are also becoming important.

4.1.1 Optimal Control

As already indicated the operation of optimal controllers was somewhat suspect in the early 1970's but after Kalman had developed the filter theory that now takes his name, the basis for Linear Quadratic Gaussian (LQG) theory (Safonov and Athans 1977) was in place. The problem of controlling spacecraft was the lynchpin in developing the method in the early 1980's (Doyle and Stein 1981). The introduction of robustness theory by Chen and Desoer (1982) allowed the development of new variants of optimal control, the H. method (Francis and Zames 1984) and μ synthesis (Macfarlane and Glover 1989 and Macfarlane and Glover 1992) method. These methods although still under review and development, have been applied successfully to several aircraft systems, notably the X-29 in the USA and to the control of a harbour gate in the UK. They have now been overtaken by the use of Fuzzy control in many respects.

Digital control has been in use since the early 1950's in machine tool applications and there are several claimants to be the originator. As the speed of microprocessors increases the need for separate discrete analysis will disappear. All the methods described herein have been executed in a discrete form.

Another area of optimal control still used is in the tuning of PID control parameters. Graham and Lathrop (1953) introduced the method. Lightbody and Irwin (1994) designed a neural network based auto-tuned regulator. The principle was proved on second order plants and then applied to a non-linear chemical reactor. Recent developments in this have been made by Wang and Wu (1995) & Kocijan et al. (1995).

Multi-loop PID controllers are still in common use. They use goal attainment, based on a root-locus method for each of the loops, derived optimally.

4.1.2 Pseudo-Derivative Feedback (PDF)

The novel controller devised by Phelan in the 1960's has not been widely adopted. This is largely because it was devised at a time when optimal control made its debut. It does have some advantages over the commonly (still) used PID controller. Phelan developed his controller ideas in several ways, the first of which was to divide the system into sub-variable loops (1981). This method can be extended to any degree and has several advantages to simplify design. Phelan and Chen (1983) expanded this with practical results. Phelan then examined systems with time delays (1986) in some detail showing that PDF control outperformed other controllers at this task.

4.1.3 Fuzzy Control

Zadeh invented fuzzy system theory in the late 1960's. Mamdani (1974) made the first application to a control system. Mamdani was a fellow research student with the author at Queen Mary College in the late 1960's. This controller was applied to a steam engine. Efstathiou (1987) extended the work of Mamdani to process control. He showed that the controller was robust.

The Japanese Ministry of International Trade and Industry (MITI) set up a special research Institute for Fuzzy Control. They developed hardware as special microprocessor chips as well as software solutions. They used these products in several consumer items such as cameras and washing machines. A fuzzy controller was also used in a VW Golf GTI car engine idling system (Kruse 1993)

The state-of-the-art in 1993 is illustrated by Kandel and Langholz. This volume covers topics such as learning algorithms, unified theory for fuzzy controllers,

different structures from that of Mamdani, VLSI implementation and dynamic analysis of fuzzy controllers.

Wang and Jordan (1994) investigated the dynamic performance of a fuzzy logic control system. They showed that the scaling range of parameters for a robust performance was quite narrow.

Chen and Hoberock (1995) implemented a multilayer MIMO Fuzzy logic controller. This was used to control vision parameters in a large robotic dishwashing system. Both gain and offset were controlled to achieve better performance than with a single layer fuzzy system. Kim et al. (1995) used an eye-in-hand camera to slave a robot. To achieve a solution to the inverse Jacobian problem a fuzzy controller was used. The Fuzzy rules were tuned automatically.

Fuzzy logic controllers can be used to control a variety of mechanisms as in the control of an inverted pendulum by Meashio et al. (1996). They can also be used to tune conventional controllers as in the work of Schmidt et al. (1996) applied to extremely non-linear hydraulic mechanisms. They found that the controller was not robust to plant uncertainties.

It has been shown that Fuzzy can be used on almost every type of control system.

4.1.4 Neural Network Control

Artificial Neural Networks (ANN's) have some of the characteristics and capabilities of the human brain, such as parallel processing, learning, non-linear mapping, and generalisation. Most artificial networks operate on layers of n artificial neurons. Within a given layer, none of the neurons are connected together, but each artificial neuron is connected to every neuron in the next layer of m neurons. The neural networks are usually taught by a lengthy process to recognise patterns. This learning process takes many trials. Their use in control has become much more important in this decade. However their use has been somewhat overshadowed by the advent of fuzzy control. ANNs are used when a specific model of the system is either not available or is too uncertain for conventional controllers to be designed.

Two papers in the early part of the decade address two important problems. One is how dynamic systems can be identified and controlled. Narendra and Parthasarathy (1990) showed that these problems were technically feasible and indicated the methods that would be successful in achieving this. Observations about the stability of the resulting system were made. The second by Kraft and Campagna (1990) addressed the problem of comparability between ANN control and more conventional control, such as a least squares self-tuning regulator and a Lyapunov model reference adaptive controller. The results were comparable but the Lyapunov controller used less actuator output, but was prone to noise.

Wang and Broome (1994) at the University of Sheffield used a neural network to tune a PID controlled robot. The advantage of this scheme was that the existing robot control system could still be used.

At Glasgow University Ge and Postlethwaite (1995) have shown how the methods have advanced, applying the method to control flexible joint robots. In this paper singular perturbation techniques are used to model elastic forces as fast variables and inertia forces as slow variables. Unlike many ANN's in the literature the inverse dynamic model evaluation is not necessary. It is not necessary to train the network; it only has to be initialised with approximate values based on the initial posture of the robot.

Oh, Park and Nam (1995) describe a neural network control of a robot in real time using position detectors. They claim a standard deviation in tracking error of 0.3 mm. More recently Lin and Yih (1996) derive an error back-propagation learning algorithm for the control of a flexible link robot. Connection of the weights of one ANN to control the link is derived via the error back-propagation of another network incorporated with the rigid model for identifying the forward dynamics of the flexible manipulator. Robustness of the network with respect to the payload is insufficient at the present stage of development.

This brings out the primary criticism of ANNs, by Warwick (1994) that they are not capable of producing a robust control system.

4.1.5 Transputer implementation

Transputers were originally manufactured by Inmos Ltd a British company but have now been bought out by a French concern. The first Transputer, the T414, was introduced in 1985. The Transputer is a parallel-processing device; in fact it is a miniature computer CPU on a chip. It has onboard memory and communications as well as processing units. Development of its use has been championed by the SERC and later by EPSRC and the DTI. Very successful clubs were established of academic and industrial users who were provided with the means to apply the device to new areas of research. The Transputer is widely used on the continent and in the USA. There is little doubt that if it had been an American chip every PC would now use a Transputer and not a Pentium processor.

Bakkers et al. (1992) describe the use of Transputers in Mechatronic control. They illustrate the use of layer architecture with a T414. They had developed a real time language TASC to cater with the timing problems of real time control. The operation was at a rate of 1 kHz.

Virk and Tahir (1992) on the other hand used multi-Transputers to achieve optimal control of aircraft in real time. They give comparisons of several different network approaches to solve the same problem. A tree network appears to give the best performance, although the cycle time of the collective mode array is least.

Holding and Sago (1992) gave a formal approach to the control of high-speed machinery. They use petri-nets to produce a formal programming technique with fault tolerance including synchronisation logic.

4.2 CONTROL RESEARCH at MIDDLESEX

The work described here deals with the procedure of implementation of optimal algorithms. Original work on the viability of the PDF algorithm is also outlined here.

4.2.1 Transputer Control

Faster control was, and is limited by the serial nature of the microprocessors of the time. The then (1985) new parallel Transputer chip with onboard memory and communications made it possible for the first time to implement some of the Optimal State-Space controllers that had been devised in the USA in the early 1980s, for fast physical processes such as film copying, in real time. Transputers made available by SERC supported this work. Mechatronic machines combine the use of computer hardware and software to make possible devices that are not possible using other means, in this case a film-copying rig. Our work was carried out in conjunction with Metrocolor that is the second largest cine-film processing company in the world. Using transputer technology and the new optimal control algorithms a successful implementation of part of the copying process showed speed improvements of 300% over the existing machines could be achieved with greater steadiness in the visible image [20,22 & 28]. Step responses to a change in film speed demand are shown in fig 4.1. This, one of the first working truly mechatronic machines was developed by a student under the supervision of the author using the author's ideas about control strategy. The overall approach was to use a more rigid version of a copying machine with the motion provided by direct drive DC motors. The film was not driven by the sprockets but by a split friction roller. The slip was controlled by the software. Unlike conventional machines no buffer loops were provided; both rollers were driven. Film speed was measured with a digital optical sensor registering the sprockets; both film tension and speed were controlled with the optimal control system. A Kalman filter was used to provide the states that were not observed. One of the Transputers ran the software for the Kalman filter while the others shared the rest of the data acquisition and control between them. No similar machines of superior performance have yet appeared.

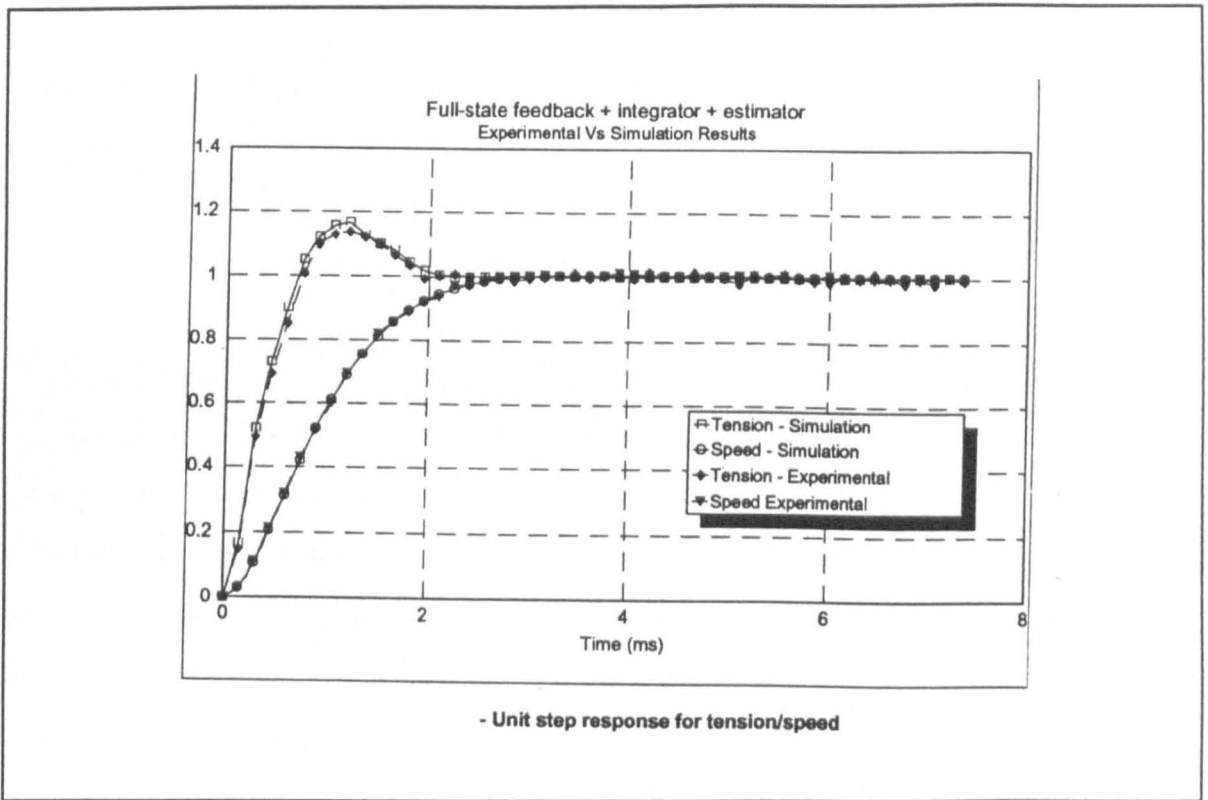

Figure 4.1 Step response of film winding system

4.3.2 PDF controllers

Several US authors have commented on the novel idea contained in Professor Phelan’s controller. This is the principle of one master. In the PID controller, for example, the three terms all try to oppose each other. As Phelan correctly observes this is quite wasteful of control energy. His controller has only action in the forward path (fig 4.2). Although it appears to only include two terms it can give results which are superior to the conventional three-term controller. The controller was derived from a feedback of a velocity signal, but is not actually measured, hence pseudo-derivative feedback. It is interesting to compare the transfer functions of a PDF and PID controllers:

Table 4.1 Comparative Transfer Functions

PID Transfer Function	PDF Transfer Function
$\frac{k(s+k_D s^2+k_I)G}{[s+k(s+k_D s^2+k_I)G]}$	$\frac{k_1 G}{[s(1+k_2 G)+k_1 G]}$

This results in some interesting properties, particularly with respect to disturbance suppression.

Table 4.2 Comparative System Properties

PID properties	PDF properties
2 new zeroes introduced	No new zeroes introduced
Denominator of order $n+1$	Denominator of order $n+1$
Numerator of order $m+2$	Numerator of order m
3 terms in denominator which can be tuned for stability	2 terms in denominator which can be tuned for stability
K affects system gain	Only k_1 affects the system gain
	Denominator same for PID with $k_D=0$
Disturbance $\Rightarrow 0$ as $t \rightarrow \infty$	Disturbance $\Rightarrow 0$ as $t \rightarrow \infty$

The main advantages of the PDF algorithm with respect to the PID controller are

- * Reduced overshoot due to lack of zeros
- * No real derivative, so reduced noise response.

The disadvantages are that it cannot stabilise some systems that are unstable, that can be stabilised by a PID controller. For system response particularly in robotics the smaller overshoot due to the absence of the two extra zeros is an important attribute.

Two areas of work by the author have shown how the controller can be effective. Standard rules by Zeigler and Nicholls are normally used to tune a PID controller, whereas Wang and Wu used an analytical procedure to tune multi-loop PID controllers. To produce a similar database the author together with an undergraduate student produced tuning results using a computer simulation for the PDF algorithm. In this procedure[32] a bivariate search is established within an ACSL simulation of a system response to a step response. Several orders and types of system were

investigated, and this work is continuing. In this method the coefficients of the controller are chosen to minimise a weighted error criterion. This criterion can be chosen at will and is similar to that conventionally use by Wang and Wu. The coefficients are entered in the programme code and can be switched on for any procedure. The programme is fully interactive and the operator can choose the limits of the responses. When this is used with systems that are stable the PDF is superior to a PID controller up to a third order system.

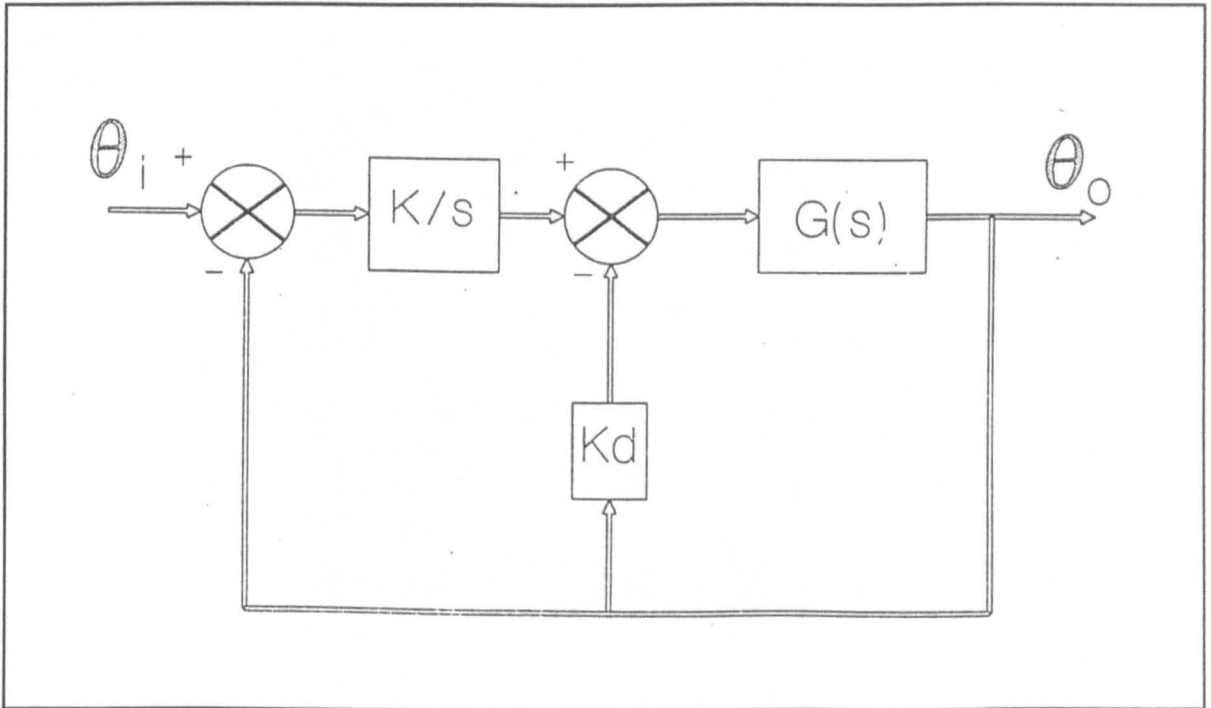

Figure 4.2 PDF controller

Phelan has used his controller primarily with systems that include a time delay. In the case of digital systems, time delays occur because of timing problems and computational delays. It is also quite common to model high order systems as a low order model with a time delay to represent the higher order modes. In paper [35] the author and two ERASMUS students used their project from Germany on the behaviour of an evaporator for the Hermes spaceplane to investigate the performance of the PDF controller dealing with time delays. In this case, as is typical of heat exchangers, which are governed by partial differential equations, the control model is a linear ordinary differential equation (ODE) plus a time delay. The implementation was a digital version of the PDF algorithm. This has a computational advantage over

the PID controller since no differential term has to be calculated, hence reducing the noise effects. The results were significant, producing a 30% better step response than the PID controller

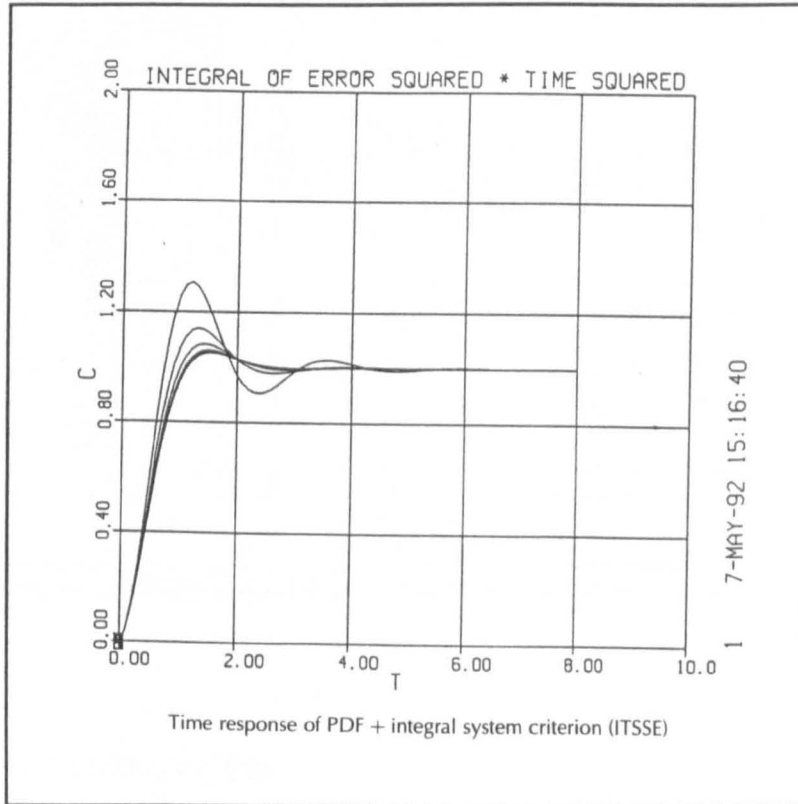

Figure 4.3 Optimising simulation results

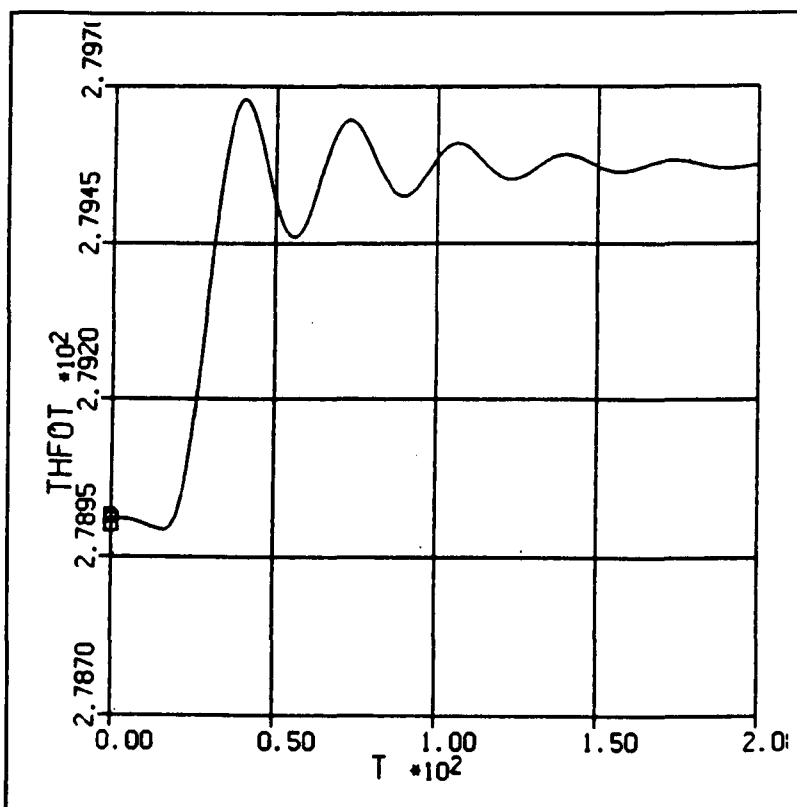

Figure 4.4 PDF control of a thermal system with time delay

4.3 ROBOT VIBRATIONS

The advent of robots in the 1960's presented the control designers of the day with difficult control problems. The eight bit microprocessors of the day were only just capable of the digital control complexity required to make such a precise tool. The early PUMA robots used some analogue controllers to achieve the necessary flexibility. It was realised that to increase the accuracy of the device for precision assembly, the effects of vibration had to be taken into account.

All machines are flexible and robots excessively so; they exhibit non-linear stiffness in the arms together with backlash and flexibility in the joints. Before any attempt is made to compensate for vibrations present in robots the general behaviour must be identified. The earliest work in this area was due to Burckhardt and Gerelle (1980) from Switzerland. They identified vertical and horizontal frequencies for the Tralfa TR 3000 W robot of 9 Hz and 17 Hz respectively. They also commented on the fact that this robot is less stiff than the human arm. J. Rees-Jones (1983) was the next to

offer vibration data for a hydraulic robot. Warnecke, Schraft and Wanner(1985) measured the modal behaviour of a Unimation PUMA 560 robot at the Fraunhofer Institute in Stuttgart. They established the effects of pose angle and determined the lowest frequency to be 19 Hz. Bosnick and Sommer(1987) tested a General Electric A4 industrial robot and obtained the modal values for this machine. This is a SCARA type robot and is much stiffer than a robot of the PUMA type. Despite this they established the lowest mode to be at 9 Hz, with 3 others below 20 Hz. Russian experiments and theoretical approaches by Gradetskii et al. (1985) yielded a low frequency mode of 13 Hz for a RPM-25 industrial robot.

In 1987 Leu, Dukovski and Wang made a comprehensive study of the effects of elasticity on a range of parallelogram robots including a GE P-50. The compliance of the joints, bearings and arms were measured. Agreement with theory was within 10%.

4.3.1 Modelling

Modelling of robot structures is difficult since they are structures supported by an elastic bearing at one end and carry a substantial payload at the other. Often they consist of an incomplete tube with several cutouts covered by bolted plates. They may be of cast, machined or welded construction. They are generally not a thin Euler beams yet researchers, often electronics engineers, persist in modelling them as such in order to produce a linear optimal controller.

Several authors have used a Lagrangian formulation to model robots. These include Bejczy and Paul (1981) and Chernousko et al. (1986) Chernousko et al. add the flexible structure motions to the rigid body motion solutions. Although analytically clever these methods can lead to severe errors for typical industrial robots. Development of a state space model using a Lagrangian formulation and with experimental verification by Hastings and Book (1986) showed clearly the effects of the load attachment on the overall modal frequencies. Generally a clamped mass assumption gives better results. It also clearly showed the possibility of using low order models for accurate control.

A combination of finite element method and Lagrange's equations were used by Chang and Hamilton (1991) to develop the concept of the Equivalent Rigid Link System (ERLS). This method should in principle be able to cope with any type of robot. Parks and Pak (1991) use the Euler-Bernoulli derivation of the beam equations to allow for the effect of the payload. They concluded that for a transfer function representation the effect of adding a tip mass was to change the poles and zeros drastically. They conclude importantly that observability may be lost for some payload variations if only a tip sensor is used. Miu (1991) made an even more general approach. Here a physical interpretation was made of the transfer function zeros for controlled flexible mechanical systems. In any system the complex poles in the transfer function correspond to the resonant frequencies of the system. The zeros are related to the energy propagation characteristics of the flexible system. For elastic beams the complex zeros are related to the resonant frequencies of the constrained sub-structure. Real zeros, which cause the control system to be minimum phase, are related to the non-propagation of energy. The zeros are the frequencies obtained when the structure is constrained at the locations of the sensor and actuator.

Sharan et al. (1992) describe a method using non-linear dynamic equations with a Galerkin interpretation into elemental form to reduce the overall vibration effects. Methods of computing the resulting motions are also discussed. Lin and Lee (1992) use a very similar procedure also using a Galerkin solution.

Xi and Fenton (1994) at Toronto University have devised a new method of computing the natural frequencies of manipulators. They sub-divide the modes into fast and slow sub-systems. They found that if the inertia of the link is greater than those of the joint then the natural-frequencies are dominated by this and remain constant over the workspace.

Chirikjian (1993) of John Hopkins University has compared the trajectory performance of a lumped model of a flexible manipulator and compared this with that

of a continuous model. For structures with between 15 and 35 bays there is less than 10% difference, in the actuator forces, between the lumped model and the continuous model.

Mayes and Eisler (1993) made experiments on a two link flexible manipulator at the Sandia National laboratory. A finite element model was constructed. This model was modified to match the link stiffness until the error was less than 1.5%. They also concluded that the hub motor dynamics had to be included in the overall FE model to get accurate results.

All of these methods have one major limitation that they cannot cope with robot arm sections that suffer warping when they bend. Warping is a phenomenon that occurs in open sections, when they are loaded in bending, where the edges of the open section do not remain in the same plane.

4.3.2 Open-Loop Control

The reference to open-loop control does not of course mean that the robot joints are controlled open loop but that the end-effector position is not controlled. This is the normal situation since the robot arm is assumed to be rigid by the designer of the robot controller for existing robots. It has been noticed that different vibration results were obtained for the same arm if the controller was altered. This led Meckl and Seering (1985) to propose open-loop controllers using bang-bang control switched so that the vibration modes were compensated. Kuntze and Jacobasch (1985) implemented a filtering algorithm that used pole/zero cancellation to eliminate the effects of flexibility. They also made a reduction in the effects due to backlash and non-linear friction. Choura, Jayasuriya and Medick (1991) devised a similar procedure to modify the angular velocity profile from the input to the controller to suppress the unwanted vibration modes. This method was applied to a simple beam for experimental confirmation.

Bhat, Tanaka and Mui (1991) used a different technique to that of Choura et al. They used the fact that an open loop system can be controlled precisely if the open loop

transfer function is known exactly. They measured very precisely the open loop modes of vibration in a thin beam. They then used polynomial input functions to derive the exact control form to achieve a given output. They also tried minimum norm and truncated square wave (bang-bang) inputs to achieve the same goal. Foster and Silverberg (1991) tried a similar method based on a minimum energy criterion trying to minimise the fuel consumed by the actuator. The results shown are *not* impressive.

Several other authors including Lin (1993) have investigated the idea of input shaping to precondition the command input. This was designed by a pole/zero placement method. It was claimed to be superior to other methods but no comparisons are presented.

Chen and Zheng (1993) proposed two passive approaches to solve the vibration problem. One is a redesigned path that does not induce large amounts of vibration. The residual is dealt with by the second method using a rubber mounting which absorbs the vibration remaining. This method does appear to work. Whether it is a universal solution is not so certain.

Cho and Park (1995) describe another open loop system using an input shaping pulse technique. They use decoupled modal functions to calculate the amplitude of shaping pulse train. In general it is not greatly superior to earlier efforts. Kwon et al. (1994) at Oak ridge have used fuzzy input shapers to control the vibration in long reach robots. They also successfully used robust input filters for the same purpose. Although these techniques have in general worked well the methods would require individual tuning of the robot to allow for differences in the structures and dynamic elements.

4.3.3 Sensor based Closed Loop Control

Trying to control the vibration of the end effector using non-collocated sensors and actuators looked to many researchers to be an impossible task. They set out to devise systems that would rely on a bewildering array of sensors and methods to reduce vibrations to an acceptable level.

Shigeru Futami and colleagues at Yaskawa Electric set out to do the task as simply as possible. They first (1982) examined the range of the problem, identifying non-linear stiffness in robot joints, backlash, steady state deflections as well as vibration. In 1983 they went further and used acceleration feedback on a Motorman L-10 5 axis electrically driven robot. They managed to reduce the vibration by a factor of 2 in peak values and the settling time by five times.

Cannon and Schmitz performed the most important series of experiments at Stanford University (1984). They showed experimentally that the concept of controlling a flexible arm using only an actuator and sensor at the driven shoulder joint was difficult. They also devised a Linear Quadratic Gaussian (LQG) controller that provided good control with a tip sensor and an estimator to obtain all the other non-measured states. It was found that control of the tip motion could not be achieved until the travelling wave from the root had reached the tip.

Fukuda and Kuribayashi (1984) used a control method based on modal separation using strain gauges to measure the root bending moment. This method could also be used to control collision with objects. Singh and Schy (1985) proposed a mode-decoupling controller for a PUMA type robot. Simulation results showed that the combination of non-linear decoupling and elastic stabilisation permits rapid and accurate tracking of large joint commands with a well-damped elastic response. Marino and Nicosia (1985) used a Lagrangian model with singular perturbation techniques to guarantee accurate asymptotic tracking.

Bailey and Hubbard (1985) proposed a different technique. They used a piezo-electric polymer to provide active control of a cantilever beam. Although this was designed to work on spacecraft it is entirely suitable for robot arms. Lyapunov control laws were tried as well as negative constant gain velocity feedback and negative constant amplitude velocity feedback. Both methods work well.

Design of a large tree moving lifting arm was investigated by Kärkkäinen (1985) who suggested the use of modal synthesis. A low order model is assumed and then pole placement or a linear optimal controller is used to provide the necessary feedback.

Toshio Fukuda (1985) now at the University of Tokyo expanded on his method of low order modal analysis based on the simplified Euler-bending theory. Strain gauges were used to feed back state signals in an optimal state-space controller. Although not a wholly robust system the results are impressive. A reduction of 50% in settling time was achieved.

In the Soviet Union Chernousko and Rogov (1985) developed an optimal switching technique, using a Lyapunov method, to control a robot with flexibility driven by an electric motor.

The control of large flexible structures in space has a great similarity to that of robots. Sidman and Franklin (1986) investigated a flexible four rotor structure at Stanford University. An on-line system identification procedure was used together with an adaptive controller using Radial Pole-Projection. Radial pole projection dynamically assigns the location of the closed loop poles by projection of resonant open-loop poles in the direction of the Z-plane origin and utilises the result of *a priori* LQG design for the placement of rigid body modes. The step responses presented are very good with minimal overshoot. Van Den Bossche et al (1986) also used an adaptive controller but with a finite element model. Identification with a spectrum analyser using modal analysis and recursive parametric identification gave an eighth order model. Unfortunately the LQG controller used did not give good results. The response contained substantial high frequency signals.

At the winter meeting of ASME in 1986 several authors presented papers that gave indications of the progress achieved at that time. Tilley, Cannon and Kraft (1986) devised an end point force control for a very fast acting end effector on a flexible arm. The controller used LQG methods with command shaping and feedforward to achieve controllable tip forces. Hastings and Book (1986) devised reduced order observers for the flexible variables for their controller. It was found that the controller was most sensitive to modal velocity gains produced by the observer. Instabilities occurred in the modes that had been truncated from the reduced order model. Slow observers aggravated this control "spill over" into the higher modes. Alberts, Dickerson and

Book (1986) investigated the addition of a visco-elastic layer to provide distributed damping in the beam and obtained the transfer functions for this system. It was found that although the lower frequencies were altered, the frequencies were almost unchanged. Modelling was possible and gave similar transfer functions to those of purely elastic beams. Wang and Vidyasagar(1991) described the control of a flexible beam using the stable factorisation method. A two-parameter compensator was implemented and gave good results.

Plump, Hubbard and Bailey continued their work at MIT (1987) investigating the use of piezoelectric film to achieve vibration control off a continuous beam for space applications. Similar to their previous efforts they continued to use a Lyapunov controller but with greater success.

Investigations for a Mast flight system to be flown on the space shuttle by Wie (1988) used a novel control method. He modelled the mast as a uniform beam with a tip mass. The system is modelled with a transcendental transfer function with exact poles and zeros. A new generalised structural filtering concept was employed to phase-stabilise the second bending mode. It was claimed that it could be extended to state space format. The effect of microprocessor implementation was included in the calculations. Tip overshoot responses are still extremely high with this method. Bhat and Miu (1991) extended their work on open loop Laplace domain work to include feedforward information based on a polynomial interpretation of the modal shape. This proved to be extremely effective for the design of disc drive read/write heads. Errors of less than 1% in point to point control were obtained. At about the same time Habib and Radcliffe (1991) were using active vibration control of a modified simply supported beam using Euler-Bernoulli theory, observing the axial velocity of the beam and applying a modified bang-bang variation of beam tensile stress to control the beam transverse stiffness. An asymptotically stable result is obtained with reduction to 26% in five cycles. This is not as good as other control techniques. Jiang et al. (1991) obtained similar results using two piezoelectric bimorphs instead of film. 1991 was an extremely good year for work in this area and Wang and Vidyasagar (1991a) showed that it was not possible to obtain feedback linearisation control of 5 bar

linkages with a single flexible link. They went on to show (1991b) that by using an observer for the flexible link, the system could be made stable in a local sense and hence controlled.

One important aspect of the robot payload problem is that the exact value of the payload mass is often unknown. Alder and Rock (1991) investigated the problem of handling non-rigid bodies such as containers of liquid. They experimented with endpoint feedback to determine the effects of unmodelled dynamics.

The twin problems of controllability and accessibility were addressed by Tosunoglu et al. (1992). Although all robots with rigid links can maintain full controllability, this was not generally found to be the case for flexible robots. A system is defined to be accessible if it is possible to model all positions where an oscillation component can be directly affected by at least one of the actuators. No actuator can therefore affect at least one oscillation if the robot is in an inaccessible position. It may not be possible to control the flexibility in this case.

All of the approaches discussed thus far only deal with single link problems. Nathan and Singh (1991) used sliding mode control on a two-link arm with fair reduction of the vibrations. They used combinations of feedforward and feedback control to achieve good tracking. Siciliano et al. (1992) used output state feedback based on a Lagrangian model to produce oscillatory but stable results for step commands also in a two-link robot.

Feliu et al. (1992) used a completely different approach, modelling the continuous beam as a set of lumped masses connected by springs. Several sensors were used to detect intermediate positions of the beam other than just the root and tip. Motor dynamics were also included. Two nested feedback loops are used to control the system together with a feedforward loop. Tests on a single link arm gave good responses when the feedforward term was active.

An extremely sophisticated theory was developed by Lu et al. (1992). This theory, an Integrated Lattice Filter adaptive Control System is used with off-line computations.

Simulated results show a reduction in settling time of 82% compared with the uncontrolled system.

An interesting variation by Matsuno et al. (1994) treats a flexible beam in which the bending and torsional vibrations are decoupled. A separate motor using calculations in Hilbert space controls each set of vibrations. It would appear to be quite as good as other methods.

Zaki and Elmaraghy (1994) from Western Ontario have used a finite element model to derive a gain-scheduling controller and secondly a model reference controller. Both were successful in reducing the end point vibration to acceptable limits. Purdy (1994) used a Linear Quadratic controller augmented with the integral of tip angle error. The simulated results show excellent performance to a step demand.

The whole field is now advanced sufficiently for textbooks to appear. Readman (1994) reviews the modelling of flexible joint robots, and the various control methods that have been used by various researchers.

A novel approach used by Lew and Trudnowski (1996) involved the use of a macro/micro robot system. This trial used industrial robots to achieve a 200% reduction in vibration levels using inertia feedback (acceleration control). Similar work was performed by Yashkawa et al. (1996). Initially PD control was used but more modern control algorithms are to be used in future. Vibration control experiments on SCARA type robots are rare although one exception is shown in the work of Luo et al. (1996). They used shear force feedback to achieve a result based on transforming the partial differential equation into a standard boundary moment control problem. Experiments on set point control as well as trajectory tracking were conducted.

A novel development introduced by Milford and Asokanthan (1996) was to find the transfer function representation of the slewing arm by using a frequency domain least squares technique. This has the advantage of being able to cope with payload variations. An LQG controller was designed using a Kalman Filter to provide the

missing states. The whole process is operated as an adaptive controller. The final vibration reduction of a factor of 5 is impressive.

Generally the methods described above indicate a whole panoply of devices and techniques able to suppress beam vibrations in single and multi-link robots. Some of these methods are complex and do not warrant the development time but others are extremely good with relatively simple procedures.

4.4 ROBOT VIBRATION CONTROL at MIDDLESEX

To make more efficient use of robots they have to be made both faster and cheaper. The development of cheaper robots requires that they be made lighter to use smaller motors and gearboxes. This would result in a much more flexible robot with serious implications for the accuracy. Mechatronic principles show that this accuracy could be restored using active vibration control. In order to have a basis for comparison, a PhD programme was initiated, supervised by the author, to measure the existing performance of robots and then to make the response more rapid. The vibration experiments that were conducted using the latest modal analysis equipment of that period, a Frequency Response Analyser (FRA) and a Real Time Analyser (RTA). Extremely low natural frequencies of vibration were found [12 & 13] limiting the speed of response of the existing robots. This vibration data, shown in fig 4.5, was some of the earliest available in this field.

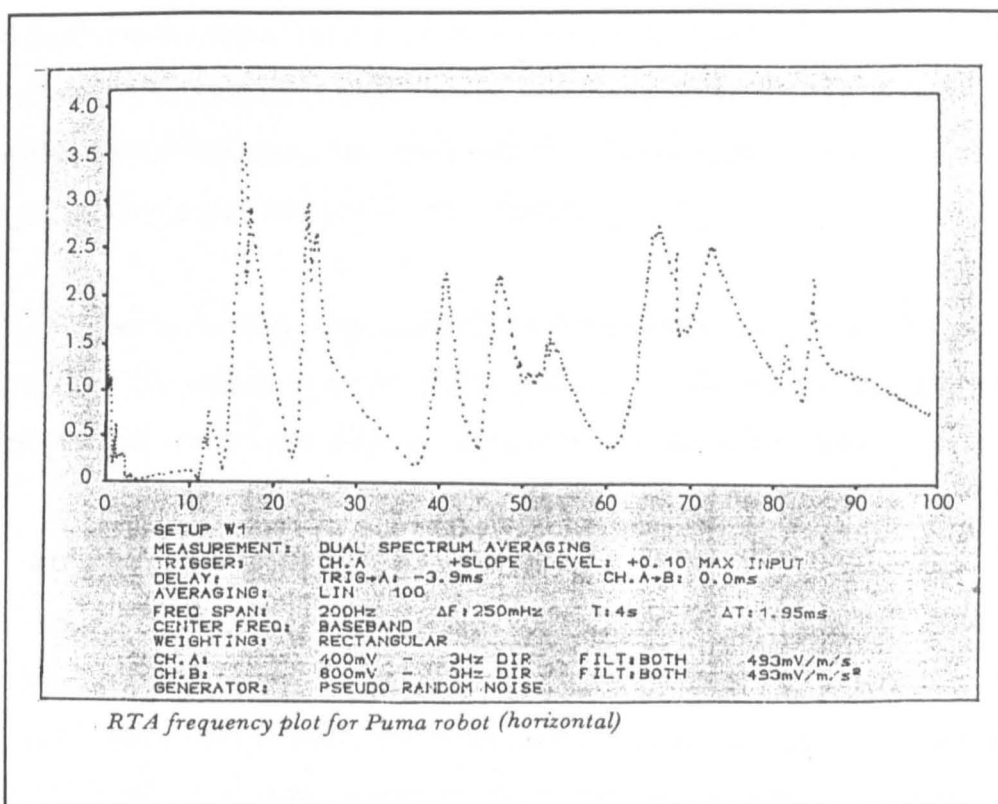

Figure 4.5 Puma modal data

Fast robots are limited by their inherent flexibility. In order to design a robot to take advantage of higher speeds a validated simulation was produced [17], using a finite difference model, wholly by the author, which is still in use today in our test of Fuzzy Control Algorithms. (See 3.12) This was validated against theoretical analysis and experimental data. All the investigations of robot flexibility were summarised in [19] in which the authors' contribution to the testing procedure and interpretation of the material is clearly shown. The models that were used by other workers (4.3) are not the same as that used by the author. They have tended to use finite element models or modal representations. (This primarily because they tend to be electronics engineers.) Both require considerable assumption of linearity and cannot be altered easily to include cutouts in the structure as in most commercial robots, nor can they allow for non-linear gearbox elasticity or friction. The author's model can cope with all these. To obtain a linear model by modal testing has recently proved extremely difficult even on a closed tube robot arm. Often a high gear ratio is used and this exaggerates the effect of gearbox and motor friction.

The author's model and experimental data are fully validated, whereas other workers rarely show any validation of their models. However the experimental data given by Warnecke et al (1985) agrees very well with the authors work. The simulation model is quite comparable with that of Chirkjian (1993).

One major finding from the experiments and simulation work is that it is possible to model a robot for control purposes taking account of only the fundamental mode of oscillation. This is due to the large damping effects of the motor magnetic field.

4.4.1 Robot Vibrations and Novel Controllers

The overall approach to the control of flexible manipulators was summarised by the author [31]. Most robots have low fundamental natural frequencies ranging from about 5 Hz to 50 Hz. Control algorithms that have been used by workers in the field include weighted open-loop controllers, adaptive control, acceleration feedback and various forward path filters. The author's contribution has been to examine the possibility of controlling the vibration using no feedback sensors but using a different algorithm that reduces disturbance sensitivity. In essence this type of control provides a shaped filter open loop controller as far as the tip of the end effector is concerned.

To obtain the optimum results for these new controllers the constants in the algorithms were obtained using an optimising simulation package [32], which can allow any cost function to be used and find the optimum value of a large number of constants. The author used a PDF controller on a reduced order robot model [26 & 31] to show how the vibrations could be reduced. For higher order models the PDF controller was not so effective. This is due to the location of a large number of vibration poles close to the imaginary axis in a low damping metal structure. We are now examining whether a model with a time delay representation of the higher modes will produce a realisable controller. Other experiments have shown that a PD controller is effective but a PID controller does not work at all. Similarly to the PDF it is the pole at the origin of the root locus, which is responsible for the problems. Poles close to the imaginary axis represent the natural vibrations. When the extra

controller pole is introduced the locus cannot be prevented from moving into the right hand half of the plane and hence becomes unstable.

Other workers, Cannon et al. for example have used optical sensors to detect the elastic deflection of their robot arms, but the author and his students have taken this a stage further. In the configuration designed by us the position of the robot is designated by a laser mounted inside the arm [25] (fig 4.6) and the deviation between the designated path and the robot arm is detected by a quadrant detector. The controller operates to reduce this error thus compensating automatically for load and other deflections. Initially, PD control was used but now a fuzzy controller has been developed.

Fuzzy control is based on the work of Zadeh and Mamdani who devised the basis of this method in the 1970's. Here data is considered to be non-exact or fuzzy. The controlled variable can be considered to be large, medium or small and control action can be invoked on this basis. Despite appearing to be crude it is a very powerful technique and has proved to be superior to conventional control methods in this case [36]. The effectiveness of this controller is superior to all those tried at Middlesex (fig 4.7). We are now in the process of building an optimal LQG controller to compare with the fuzzy controller.

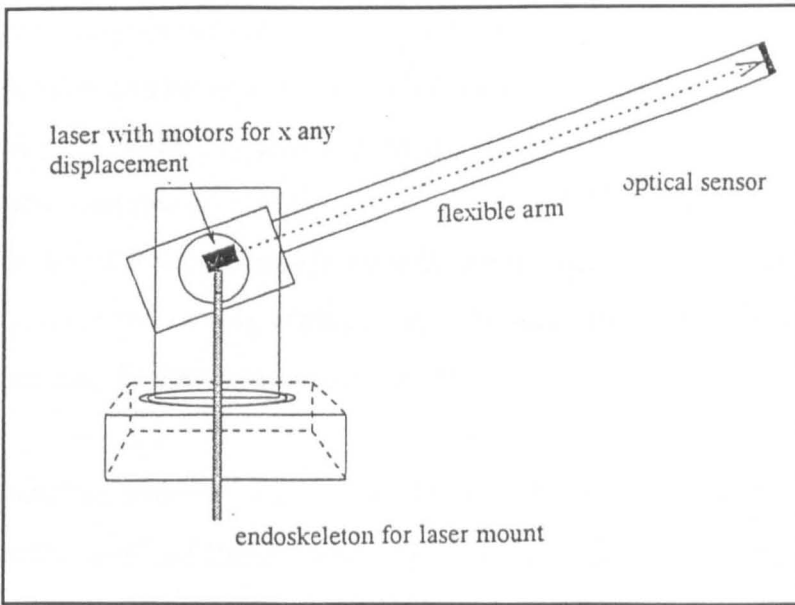

Figure 4.6 Optically guided robot

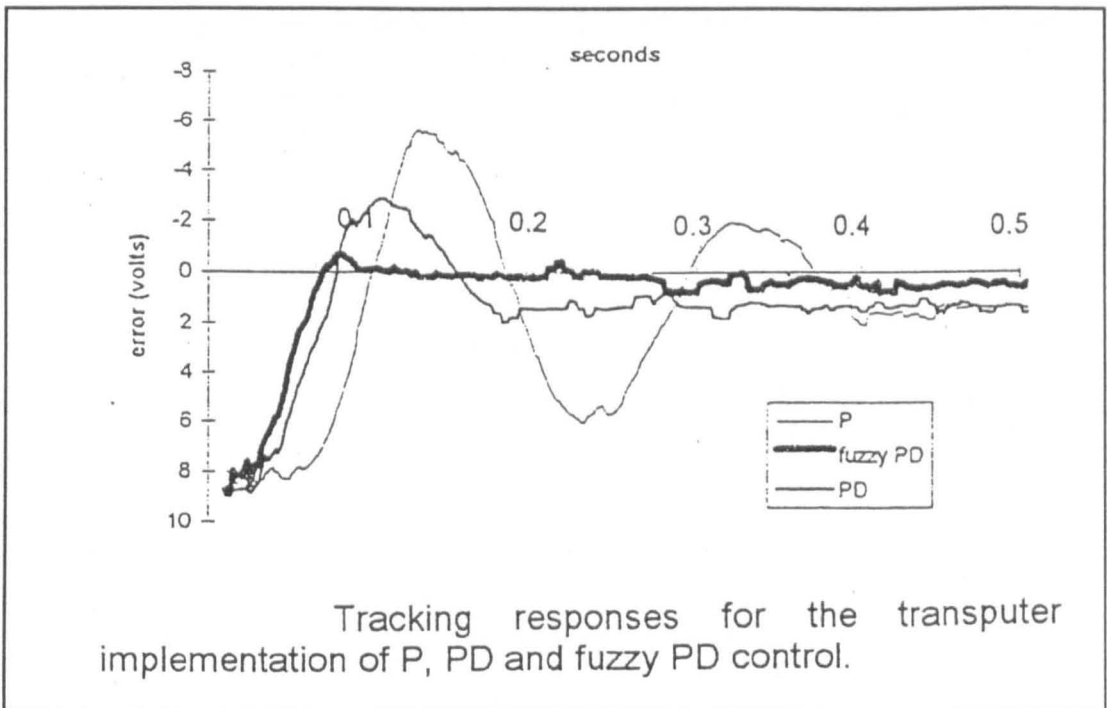

Figure 4.7 Fuzzy Controlled Robot Performance

4.5 SUMMARY

In the early 1980's there were few examples of successful implementation of optimal LQG control on real hardware; in fact there are still few working systems. The number of applications using parallel processing is even fewer. Most published work

turns out to be merely simulation. As a result of our work on the control of film copying is considered to be superior to that of most other workers of the period. The rig was improved by 300% in speed and the tension controlled to within 10% whereas it was totally uncontrolled previously.

The work with the PDF controller agreed with the findings of Phelan and extended this work to produce new tuning information. The author's work concerning the investigation of this algorithm is almost unique.

The data generated from measurements of robot vibration modes was amongst the earliest of this kind published, certainly in Europe. The novel robot guidance technique using optical sensors has proved to be well able to cope with load variations of 200% of the arm mass. The Fuzzy controller developed for this robot has proved so far to be up to 50% quicker than conventional PD control with no overshoot.

Chapter 5

REGENERATIVE and FRICTION PROCESSES

5.0 INTRODUCTION

The effects of friction dominate purely mechanical systems. For example, the behaviour of a mechanism at low speeds is dominated by stick-slip and lost motion will result. This has severe repercussions for accurate positioning. Considerable intelligence is required to allow a mechanism to behave as the designer predicted when friction effects are taken into account. The system is truly undetermined because the effect of friction is to make the system velocity-dependent and since friction and wear effects increase with age, or are time-dependent with a long time constant. With suitable sensors friction or slip effects can be detected and controlled.

5.1 CONTROL of FRICTION and REGENERATIVE PROCESSES

Before the advent of digital computers, systems that contained significant friction could not be controlled precisely. It was dealt with in control using a variety of techniques; the most reliable of which was the describing function method (Atherton 1982). Most of the analytical effort was expended in determining whether the system remained stable. Performance was usually found by simulation (Doebelin 1985). The earliest example of the use of adaptive control in controlling friction was by Walrath (1984). He was able to reduce the effect of gimbal bearing friction of an airborne pointing system. An adaptive digital filter was devised using a bilinear transformation. Stabilisation errors were reduced by a factor of two.

Two areas of have been examined at Middlesex, namely Slip Prevention and Chatter control, and friction or similar effects dominate both processes. This type of non-linear problem with memory effects has proved to be difficult to control with linear state-space controllers.

5.1.1 Slip Prevention

There are two areas of current research: one dealing with vehicle traction control and the other to do with control of processes.

5.1.1.1 *Traction Control*

A typical example is given by Mazumdar and Cheng (1995) who describe the application of neural networks to an anti-skid braking system. They used a model reference adaptive controller to adapt the system to environmental changes. The controller regulates the torque to prevent slip. A second example is that of Olson and Milacic (1996) who investigated an Anti-lock Braking System (ABS) system on a military vehicle. The active system showed considerable improvements over the non-active system. Kimbrough and Datla (1996) illustrated an effective means of preventing wheelslip without measuring ground speed directly. They used an accelerometer and a wheel speed sensor to predict slip.

Fuzzy controllers were used by Bauer and Tomizuka (1996), one was used to estimate the peak slip of the road wheels and fixes the value at this value while the other regulates the slip at any desired value. It is claimed to be insensitive to varying road conditions.

5.1.1.2 *Servodrive Slippage*

Creutzmann et al. (1995) considered the problem of paper handling. They prevented slip by controlling the tension of the opposing web processes exactly. Purucker and Robinson (1996) from the University of Pittsburgh devised an air-bearing platform to study falling potential. A feedback loop is used to manipulate the friction level between translating surfaces.

Song and Cai (1996) have used a robust Lyapunov direct method designed controller to allow for the effects of stick-slip in the path control of a robot. They claim a smooth control action and smooth motion on the contact surface.

Emura, Wang and Chen (1996) describe a traction drive using disturbance compensation to eliminate the effects of stick-slip. Getz (1996) has applied neural nets and fuzzy logic to control conveyor belt slip. No details are given to see how this was achieved. Popovic et al. (1995) have used a very interesting approach in a very accurate positioning device. They use short torque pulses to achieve the desired location. This has similarities to the old fashioned technique of applying a dither signal with the command signal to overcome the friction. A precision single axis system by El-Roy and Friedland (1995) based on a printer mechanism uses a special control algorithm designed by Friedland to compensate for stick-slip. The system response is 150 ms for a 25 mm step with accuracy better than 1 micron. Huang et al. (1995) have shown that a PDF controller can overcome the problem of stick-slip. The resulting accuracy is 1 arc second using a traction drive

5.1.2 Slip Prevention in Film Copying

The relatively new technique [33] of Neural Networks has been applied to the prevention of slip in rotary motion transmission. Several different neural techniques were evaluated with conspicuous success. Unlike classical and modern systems theory neural network and fuzzy control systems do not require a system model in order to be designed. Neural networks consist of a number of components connected together, each component carrying out a different function. This allows parallel processing to take place, although serial computations within the network can be carried out. A backpropagation technique was used with a sigmoid actuation function. Here the system is up to speed within 20 ms (fig 5.1) and the NN controller performs considerably better than the original state-space controller does. This compares favourably with the controllers of Emura et al. and Huang et al.

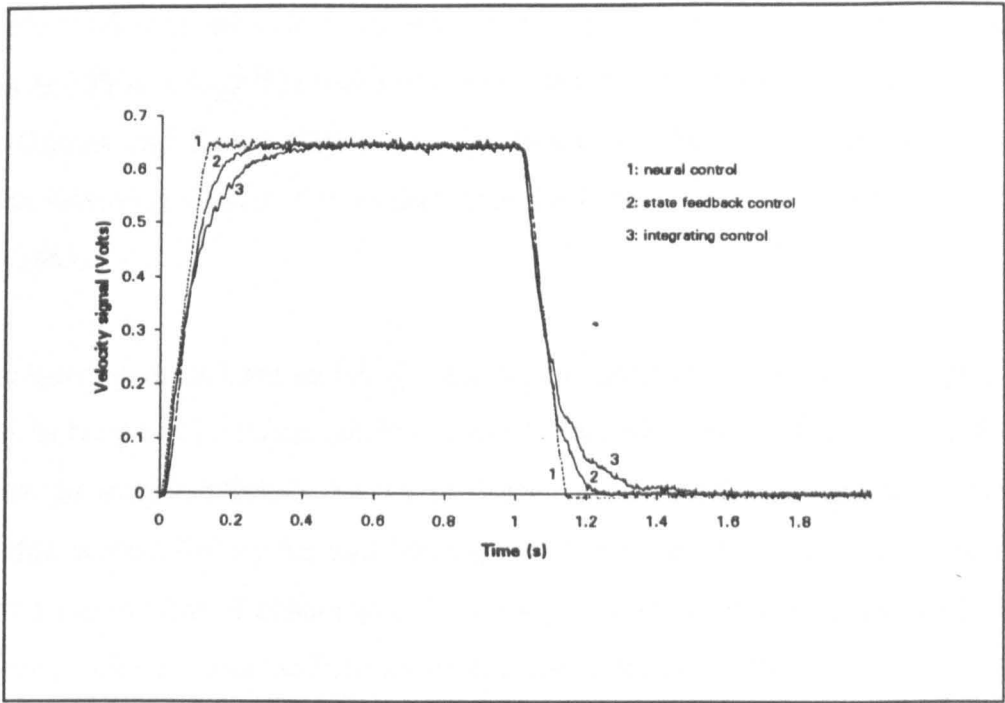

Figure 5.1 Film slip prevention with a neural network controller

5.1.3 Chatter Control

Chatter is a self-excited vibration caused by the interaction of the chip removal process and the structure of the machine tool and it is a major concern today when we are all trying to achieve high quality. The vibrations can be of quite large amplitude and result in the following:

- Poor surface finish
- Dimensional inaccuracy of the work
- Premature wear, damage and ultimately failure of the cutting tool. This is particularly important in the case of ceramic tipped tools.
- Damage to machine components from vibration.
- Loud objectionable noise.

Chatter is often initiated by a disturbance such as a lack of homogeneity in the material. Changes in the cutting friction due to insufficient cooling can also start the vibration. Regenerative chatter is the most important type of self- excited vibration. This is when the tool cuts a surface, which has roughness or disturbances from the previous cuts. It has very similar characteristics to stick-slip friction.

Arnold (1946) appears to be the first person to have investigated the phenomena of chatter while Hahn (1954) discovered the principle of regenerative vibrations. Most of

the early work was directed to obtain the stability borderlines for chatter prevention. Tobias and Fishwick (1953) made an exact solution to the three borderlines of stability while Gurney and Tobias (1962) also developed boundaries for n degree of freedom systems involving chatter. Tobias discusses the limitations of these approaches in his book (1965).

Recent developments have included a non-linear model of chatter by Tlustý and Ismail (1983). In his paper he points out that in a real machining process the vibration does not continue growing indefinitely but reaches some limiting amplitude and undergoes a limit cycle that is modelled by the tool leaving the workpiece. Shiraishi and Kume (1988) achieved suppression of chatter using a state-space controller with an estimator for the extra states inferred from the Pade approximation to the time delay.

5.1.4 Chatter Control at Middlesex

New control challenges have been undertaken in the field of machine tool chatter [29]. Chatter is an unacceptable vibration that occurs when a piece of metal is machined. A variety of novel and traditional control algorithms including Proportional and Pseudo-Differential Feedback and optimal controllers, have been investigated in order to find out the best approach to solve this problem. The basis of the work is to use active control to reduce the effect of machine tool chatter; this is shown in figure 5.2, where the reduction of vibration is clearly indicated. Various strategies have been investigated, but the most promising appears to be either the use of a micro-drive mounted on an existing machine or tool bending. This use of a microdrive would of course have greater benefit as many existing machines could be retrofitted. The results so far compare well with Shiraishi and Kume. This work has now attracted a HEFCE scholarship from the University.

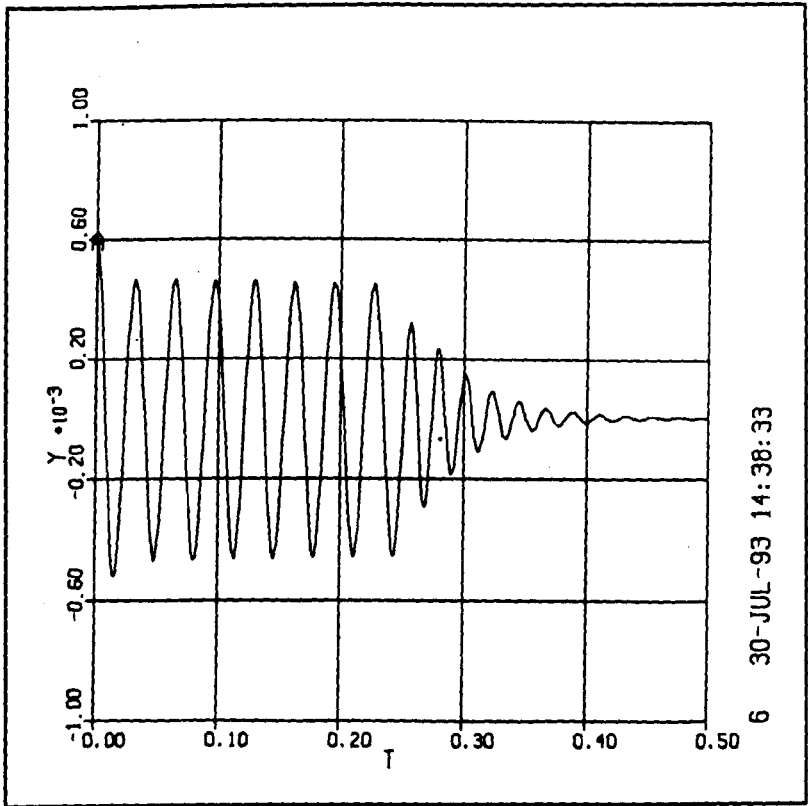

Figure 5.2 Chatter vibration reduction with PDF control

Chapter 6

DEVELOPMENT of the RESEARCH STRATEGY

6.0 INTRODUCTION

After being strongly influenced by the new approach of Japanese companies I initiated a programme of work that examined the integrated design of manufacturing automation, particularly robots. Robots were, and mostly still are, expensive devices of low mechanical accuracy and precision. To make them more effective and cheaper, Mechatronic techniques can be used to improve their dynamic accuracy, which is limited by vibrations, and reduce the cost of the motors and the fabricated parts by using electronics to stiffen the structure using active vibration control instead of making a mechanically stiffer structure.

In 1983 I transferred back to the Mechanical School from Civil Engineering. I then started to teach Dynamics and Control after the retirement of a colleague. In a sense this was returning to the work I had been doing when I was loaned to Civil Engineering 7 years before. My scholarship revealed a substantial amount of new developments in the field of optimal control that had taken place in my enforced absence. It took me two years to catch up with these developments. At this time it became clear that one major area of work that was relevant to my interests was the control of flexible structures. This fitted in well with my previous Aerodynamic experience in flutter, gained in industry. The particular problem that exercised my thoughts was that of non-collocated control of flexible structures such as robots, although this applies to whole classes of mechatronic machines.

The revolution in microprocessor technology was clear to me as a “new” entrant and particularly the power of the new microcomputers. I was the first to use PCs in the Engineering Faculty. Another new development that became available around this time was the Transputer, a novel parallel-processing chip. These were obtained on

loan from SERC and used in the control of film processing project. One of the most advanced control applications in the country at that time.

Around this time (1985) we were able to use INSET money for retraining and I arranged for the top control people from Stanford University in the USA to give us a short course to bring our staff up to the state of the art in optimal control, short-cutting a time consuming learning process. Our school was the largest user of INSET money in the country, making up for years of neglect in retraining. Due to retirements, I am now the only person at Middlesex who understands the full range of modern control theory applied to Mechatronics. I have since kept up to date attending most of the advanced short courses organised by Institution of Electronic and Electrical Engineers (IEE) in control, as well as contributing to their research colloquia. We were at the time the biggest users of Computer Aided Control System Design Software in the country, using CONTROL-C, MATLAB and ACSL all of which I introduced to research and teaching.

Around this time we were fortunate enough to obtain National Advisory Body (NAB) funding for two major projects. Together with funds from industry we were able to start projects to examine robot vibrations and the copying of cine-film both areas of work where flexibility of the medium is significant. These two projects started the whole of the Mechatronics research undertaken at Middlesex. The School of Electronics gained a foothold in this area as a result of another NAB application made by Professor K. Wright, two of the Electronics staff and myself together with a medical charity. The PhD student working on rehabilitation robotics was a former project student of mine. Both students on the other projects were former undergraduate project students of mine. In the Mechanical School this activity was co-ordinated by the Dynamics and Robotics subject group led by me. In 1991 this group was re-organised to include the Advanced Manufacturing group and became the Advanced Manufacturing and Mechatronics Centre led by Dr R. Gill.

Expansion into new Mechatronic areas followed with the development of a student project of mine and of R. Ruocco's concerned with the optical guidance of robots.

This is funded by British Nuclear Fuels (BNFL) and is part of their programme to develop flexible multi-jointed robots to disassemble nuclear reactors. This has been successful and the student has now obtained a PhD supervised by Dr. R. Gill and myself. A second student funded in part by BNFL is extending this work to include fuzzy control. Another student is now working on extending the rehabilitation robotics project; supervision is shared by me with the Electronics School. BNFL funding is also allowing another student I am supervising with R. Gill to create a new approach to path planning for robots. Yet another PhD student is analysing the design of a Mechatronic machine to aid brain-damaged children. The last area of development in the Mechatronics Centre is that of control of machine tool chatter funded by a university HEFCE funded studentship. The student appointed is critically examining the past and current theories of machine tool chatter and comparing them with his more accurately measured experiments as a first step.

A large part of the success of the Centre has been due to the considerable number of ERASMUS students from Germany and Belgium who have developed equipment and contributed to the experimental developments that have taken place. Generally the author has either initiated or participated in all the Mechatronics development that has taken place at Middlesex.

Chapter 7

DISCUSSION and CONCLUSIONS

7.0 INTRODUCTION

The purpose of this section is to address the relative merits of the work submitted herein and to compare it with the state-of-the-art at the time of its completion. My work is both currently relevant and has brought the University to a position of comparability to other research centres in Japan and the USA in these research areas.

7.1 SENSORS and ACTUATORS

Sensors developed at Middlesex are comparable in performance to other devices of similar cost. To measure the movement of a model aircraft or robot with the accuracy and frequency response to that in paper [1] would require a laser vibrometer costing £20000. It is still not possible to measure a small rotation in such a small space for a price of less than £50 with such an absence of friction. The sensor developed with R. Ruocco is better in principle than those of section 4.1 since it can deliver texture information as well as range.

The pneumatic actuator used by Prior was quite unique until recently but has now been copied and used to drive a robot as shown in section 4.2. The analysis he and I used is now being used by others to analyse the earlier McKibbern actuator. His survey work is quoted widely.

7.2 SIMULATION

The use of simulation in teaching was developed by the author for a considerable period before the connection to Mechatronics, but reached a systematic form that could be operated as a formal design scheme during the early 1980's. The use of

simulation was considerably in advance of US degree courses at that time and probably other UK degrees as well.

The principle theme was to illustrate how the processes of simulation clearly dictate the procedures of design for Mechatronic systems. Initially data about the system and its requirements have to be gathered. This is followed by a design model formulation and then its simulation. This process is highly interactive. Validation of the model is an important stage in the overall process and without validation the whole scheme is worthless. In other words the checking phase of the design process is critical to its success. For students this has proved to be an effective teaching strategy. Most textbooks do not emphasise the interactive nature of design, particularly with finite element analysis and synthesis. They do not stress the importance, as we did here, of the answers being of the right order of magnitude and concurring with other data or solutions, in fact, being validated.

7.3 CONTROL and FLEXIBLE SYSTEMS

7.3.1 Control algorithms

Control design is like any other design procedure, there are the staple solutions that work most of the time, PID for example, and then there are the occasions when they fail and more exotic methods have to be employed. In the case of the film project, applying a simple controller would not achieve the necessary requirements of a quantum leap in performance. Fortunately it was possible to measure the system parameters and hence possible to apply optimal control in a practical form. With the use of Transputers it could be computed and applied in real time. In 1985 this would not have been possible with any other microprocessor!

The use of the PDF controller in several applications was without parallel anywhere. Although several US authors have commended its use almost no reported examples exist. Consequently, work of the author is unique in this subject. The use by the

author and his students of neural networks to control slip puts the work at least equal to developments in the US and ahead of European competitors.

The investigation of Fuzzy controllers at Middlesex is only just reaching the state others were at some time ago but in the field of application to control flexible robots it is probably just ahead of comparable research. At Middlesex we use a grouping technique to enable the choice of sets to be made on the basis of data gleaned from the simulation of the flexible system.

7.3.2 Robot Vibrations

The field of robot vibrations is one in which the author has probably made his greatest contribution. Certainly we were the first in the UK to measure, on a systematic basis, robot modes of vibration. We still have measured more different types of robots than anyone else in the UK and have experience, which leads us to make the judgement about the importance of the fundamental mode of vibration in the reduction of flexible effects. Our experience also has led us to use a simulation model that is not based on a modal solution to the Euler-Bernoulli equation. However have produced results in line with other workers. The control techniques we have proposed and implemented with the optical guidance are more sophisticated than those in use elsewhere (section 4.5.3) and the proposal to use PDF control with no feedback of tip position fits in well with other researchers in section 4.5.2 but produces better results for the case where the higher order modes can be neglected. It does not appear to give as good results when more modes are included.

7.4 FRICTION and REGENERATIVE CONTROL

Friction and wear are major problems for reliability and precision particularly in micro-machines. It is increasingly likely that the Japanese will place extra effort in this direction in the near future.

7.4.1 Slip Prevention

The work done at Middlesex is very comparable with other workers. Driving the polyester film stock with the rubber traction drive using the neural network gave changes of speed within 20 ms while with the conventional controllers it took some ten times longer. It forms the basis of a co-operative bid of ours with European partners for the development of electric vehicles.

The Americans now have a vehicle in production using a Fuzzy Logic controlled traction system. Our system could have been in use with the film-copying machine two years ago but for the company declining to invest in *any* new machines.

7.4.2 Chatter Control

The work here has shown that theoretically it is possible to control chatter with a number of different methods. Various control algorithms have been tried, mostly with success. The simulation showed that the chatter could be eliminated before the operator had recognised that something was wrong. We are now comparing our data with rival theories in order to develop a satisfactory model of the process. This work will shortly be implemented in hardware.

7.5 CONCLUSIONS

The essential contributions to knowledge presented here are:

- * Novel optical sensors to measure a wind tunnel model linear and angular displacements and the position and shape of a manufactured part.
These are still in use and are cheap for their performance. In the case of the aircraft model sensors this is ± 0.5 mm and $\pm 0.1^\circ$, and in the case of the eye-in-hand sensor, of the order of ± 0.25 mm.

- * Original measurements of vibration modes for industrial robots. These were made for polar, SCARA and cylindrical types of robots.
These results agree well with other workers. The tests on industrial robots show that the lowest frequency mode is extremely dominant and the higher modes are much less important than in research robots made from tubes or other continuous structures.
- * Implementation of optimal LQG controller on a working transputer controlled rig.
This was an early and almost unique application to a winding process. At the time of implementation it was one of the most significant applications of optimal control in the UK. No other winding controlled process has been able to demonstrate 300% improvement in process rate.
- * Contribution to the development of a new pneumatic actuator for robot application.
This actuator has the advantage for rehabilitation robots of low cost and useful compliance.
- * Investigation of non-standard control algorithms in controlling machine tools and mechanical problems such as slip.
A neural network controller was successfully developed to prevent slip. This controller is as effective as current work in the USA. I have also shown that chatter can be eliminated with unconventional PDF controllers.

References

- Agrewal, A, 1986 *Robot Eye-in Hand using Fibre Optics*, in Robot Sensors Vol.
Epstein, M, 1, Ed A. Pugh.
- Alberts, T.E, 1986 On the Transfer Function Modelling of Flexible Structures with
Dickerson, S.L, Distributed damping, *ASME DCS-Vol.3*, 23-31.
Book,W.J.
- Alder, L.J, 1994 Control of a Flexible Manipulator with Unknown Payload
Rock, S.M, Dynamics, *ASME DSC- vol 31*, 61-66.
- Arnold, R.N, 1946 Mechanism of Tool vibration in Cutting of Steel, *Proc. of the
Institution of Mechanical Engineers*, 154, 261-276.
- Athans,M, 1966 *Optimal Control*, New York,: McGraw-Hill.
- Atherton, D.P,1982 *Nonlinear Control*, Van Nostrand Reinhold.
- Auslander, D.M, 1996 What is Mechatronics?, *IEEE/ASME Trans. on Mechatronics*,
1, 1, 5-10.
- Bakkers, AWP 1992 Transputer based Control of Mechatronic Systems,
Meijer, J *Chap. 3 of Transputers in Real Time Control*, Ed by
Musters, JC *GW Irwin and PJ Fleming, Research Studies Press*
Tillema, HG *Wiley 1992*, 53-94.
- Bailey, T, 1985 Distributed Piezo-Electric Active Vibration Control of a
Hubbard, J.E.Jr, Cantilever Beam, *Jnl. Guidance*, 8, 5, 605-611, Sept.-Oct.
- Baird, H.S, 1986 *Precise Robotic Assembly using Vision in the Hand*, in Robot
Lurie, M Sensors Vol. 1, Ed. A. Pugh

- Bennett, BS, 1995 *Simulation Fundamentals*, Prentice-Hall.
- Bejczy, A.K. 1981 Simplified Robot Arm Dynamics for Control, 20th *IEEE Conf. on Decision and Control Including the Symposium on adaptive Processes*, 261-262.
Paul, RP,
- Beuer, M, 1996 Fuzzy Logic traction controllers and their effect on longitudinal vehicle platoon systems, *Vehicle System Dynamics*, 25, 4, 277-303.
Tomizuka, M
- Bhat, S. P, 1991 Experiments on Point-to-Point Position Control of a Flexible Beam Using Laplace Transform Technique-Part 1: Open Loop
Tanaka, M
Mui, D. K *Trans ASME, Jnl of Dynamic Systems, Measurement and Control*, ,Sept., 433-437.
- Bhat, S. P, 1991 Experiments on Point-to-Point Position Control of a Flexible Beam Using Laplace Transform Technique-Part 2: Closed Loop,
Mui, D. K *Trans ASME, Jnl of Dynamic Systems, Measurement and Control*, ,Sept., 438-493.
- Bosnick, J. R 1987 Vibrational Kinematic Parameter Estimation for Robot Manipulators, *Proc. 5th Int. Conf. on Modal Analysis*, 1432-1437, London.
Sommer, H. J
- Burckhardt, CW. 1980 Dynamic Design Parameters for Robot Arms: Experimental Results, *Proc, 10 th. International Symposium on Industrial Robots*, March Milan, 321-329.
Gerelle, EGR
- Buur, J,1989 A theoretical approach to mechatronics design,
Lyngby Institute of Design, Technical University of Denmark.

- Cannon, R. H, 1984 Initial Experiments on the End-Point Control of a Flexible One-Link Robot, *Int. Jnl. of Robotics Research*, 3, 3, 62-75.
- Schmitz, E,
- Chang, L. W, 1991 The Kinematics of Robotic Manipulators With Flexible Links Using an Equivalent Rigid Link System (ELRS) Model, *Trans. ASME Jnl. Dynamic Systems, Measurement and Control*, 113, 48-53, March.
- Hamilton, J. F,
- Chen, B 1995 Fuzzy Logic Controller for Automatic Vision Parameter Adjustment in a Robotic Dish Handling system, *Proc. 10th IEEE Int. Symposium on Intelligent Control*, 332-337.
- Hoberock, LL.
- Chen, M. J, 1982 Necessary and Sufficient Conditions for Robust Stability of Linear Distributed Feedback Systems, *Int. Jnl. Control*, 35, 2, 255-267.
- Desoer, CA,
- Chen, MZ 1993 Vibration-free movement of deformable beams by robot manipulator, *Proc IEEE Int. Conf on robotics and Automation*, 456-461.
- Zheng, YF
- Chernousko, FL 1986 Simulation of Dynamics and Optimisation of Robot Systems, *Proc. 5th IFAC/IFIP/IMACS/IFORS, Suzda, USSR, April*, 199-204.
- Akulenko, L. D,
- Bolotnik, N. N,
- Gradetsky, VG
- Chernousko, F. L, 1988 Optimal Control of a Robot with Electric Drive and Elastic Element, *Robot Control* 88, *IFAC Symposium*, 91.1-91.5.
- Rogov, N. N,
- Chirikjian, G. S, 1993 A Comparison of Continuum and Lumped-Mass Models for Hyper-Redundant Manipulator Mechanics, *ASME DE-57*, 1-6.

- Cho, JK 1995 Vibration reduction in flexible systems using a time-varying
Park, YS impulse sequence, *Robotica*, 13, 3, 305-313.
- Chou, C. P, 1996 Measurement and Modelling of McKibbern Pneumatic
Hannaford, B, Artificial Muscles, *IEEE Trans. on Robotics and Automation*,
12, 1, 90-102, Feb.
- Choura, S. 1991 On the Modelling, and Open-Loop Control of a Rotating Thin
Jayasuriya, S. Flexible Beam, *Trans. ASME, Jnl. Dynamic Systems*,
Medick, M.A, *Measurement and Control*, 113, March, 27-33.
- Costa-Maniere, E 1995 Visual servoing in the task-function framework: a contour
Couvignou, P following task, *Jnl Intelligent and Robotic Systems*, 12, 1, 1-21,
Jan. Khosla, PK.
- Creutzmann, E, 1995 Paper path control at high speed electrophotographic
Eckardt, A printing, *Proc. IS&T 11th Int. Congress on Advances*
Kopp, W *in Non-Impact Printing Technologies*, 267-270.
Winter, H
Goldmann, G
- Doebelin, EO 1985 *Control System Principles and Design*, Wiley.
- Doyle, JC, 1981 Multivariable Feedback Design: Concepts for a Classical/
Stein, G, Modern Synthesis, *Trans. IEEE on Automatic Control*, Ac-26,
4-16.
- El-Roy, A, 1995 Precision single-axis motion control system with friction
Friedland, B compensation, *Proc. American Control Conf., Part 5*
3299-3302.

- Efstathiou, J, 1987 *Rule-Based Process Control Using Fuzzy Logic, in Approximate Reasoning in Intelligent Systems, Decision and Control, Pergamon Press, Ed E.Sanchez and LA Zadeh, 145-158.*
- Emura, T, 1996 *Servomechanism using traction drive, Trans. of the Japanese Society of Mechanical Engineers, Pt C, 62, 593, 141-148.*
- Wang, L,
Chen, X.
- Feliu, V, 1992 *Modelling and Control of Single-Link Flexible Arms with Lumped Masses, Trans. ASME Jnl. Dynamic Systems, Measurement and Control, 114, 59-69, March.*
- Rattan, KS
Brown, HB,
- Foster, LA, 1991 *On-Off Decentralised Control of Flexible Structures, Trans. ASME Jnl. Dynamic Systems, Measurement and Control, 113, 41-47, March.*
- Silverberg, L,
- Francis, BA, 1984 *On H_{∞} -Optimal Sensitivity Theory for SISO Feedback Systems, Trans IEEE on Automatic Control, Ac-29, 9-16.*
- Zames, G,
- Fukada, T, 1984 *Precise Positioning and Vibrational Control of Flexible Robot Arms with Consideration of Joint Elasticity, Proc. IECON 84, 410-415.*
- Kuribayashi, Y,
- Fukada, T, 1985 *Flexibility Control of Elastic Robot Arms, Jnl. Robotic Systems, 2, 1, 73-85.*
- Futami, S, 1982 *Intelligent Servo System: An Approach to Control-Configured Robot, Proc. 6th Int. Conf. on Robot Technology, 381-389, France.*
- Kyura, N,
Nanai, S.

- Ge, SS 1995 Adaptive Neural Network Controller Design for Flexible Joint Robots Using Singular Perturbation Technique, *Trans. Inst. MC.*, 17, 3, 120-131.
- Postlethwaite, I
- Getz, R, 1996 Neural nets and Fuzzy Logic improve conveyor belt slip control, *Industrial Computing*, 15, 2, 20-22.
- Gradetskii, VG 1985 Effect of Elastic Structural Compliance of Robots on their Dynamics, *Mechanics of Solids(Mekhanika Tverdogo Tela)*, 20, 3, 63-71.
- Gukasyan, AA,
Grudev, AI,
Chernousko, FL
- Graham, D. 1953 The Synthesis of Optimum Transient Response Criteria and Standard Forms, *AIEE Trans.*, 72, II
- Lathrop, RC
- Gurney, JP, 1962 A Graphical Analysis of Regenerative Machine Tool Instability, *Trans. A.S.M.E*, 84, 103.
- Tobias, SA,
- Habib, MS 1991 Active Parametric Damping of Distributed Beam Transverse Vibration, *Trans. ASME Jnl. Dynamic Systems, Measurement and Control*, 113, 295-299, June.
- Radcliffe, CJ,
- Hahn, RS, 1954 On the Theory of Regenerative Chatter in Precision Grinding Operations, *Trans. ASME*, 76, 593-597.
- Hamerlain, M 1995 Anthropomorphic robot arm driven by artificial muscles using a variable structure control, *Proc IEEE/RSJ Int. Conf. on intelligent Robots and Systems*, 550-556.
- Harashima, F, 1996 Mechatronics "What Is It, Why and How", *IEEE/ASME Trans. on Mechatronics*, 1, 1, 1-5.
- Tomizuka, M
Fukuda, T.

- Hastings, GG, 1986 Reconstruction and Reduced-Order Observation of Flexible
Book, WJ, Variables, *ASME DSC-Vol.3, 11-17.*
- Hastings, GG, 1986 Verification of a Linear Dynamic Model for Flexible Robotic
Book, WJ, Manipulators, *Proc. IEEE Int. Conf. on Robotics and
Automation, 1024-1029.*
- Holding, DJ 1992 A Formal Approach to Software Control of High Speed
Sagoo, JS Machines, *Chap. 9 in Transputers in Real Time Control, Loc.
Cit., 239-282.*
- Hung, C-J, 1995 Stability of PDF controller with Stick-slip friction device,
Yen, J-Y, *Proc. American Control Conf, Part 5, 3289-3293.*
Lu, S-S
- Isermann, R, 1996 Modelling and Design Methodology for Mechatronic Systems,
IEEE/ASME Trans on Mechatronics, 1, 1, 16-29.
- Ishihara, H, 1996 Micro Mechatronics and Micro Actuators, *IEEE/ASME
Arai, F Trans on Mechatronics, 1, 1, 68-80.*
Fukuda, T
- Jardim, J 1996 Design of an eye-in-hand robotic vision system, *Proc. 1996
Absi-Alfaro, SC. 6th Int. Offshore and Polar Engineering Conf., 4, 169-171.*
- Jiang, ZW, 1991 Position Control of a Flexible Arm Using Piezoelectric
Chonan, S, Bimorph Cells, *Trans. ASME Jnl Dynamic Systems,
Abé, H, measurement and Control, 113, 327-329.*
Tani, J.
- Kandel, A 1993 *Fuzzy Control Systems, CRC press.*
Langholz, G. Eds.

- Kärkkäinen, P, 1985 Compensation Manipulator Flexibility Effects by Modal Space Techniques, *Proc. IEEE Int. Conf. on Robotics and Automation*, 972-977.
- Kim, JG 1995 Auto-tuning fuzzy rule-based visual servoing algorithm for a
 Cha, DH slave arm, *Proc 10th IEEE Symposium on Intelligent Control*,
 Cho, HS 177-182.
 Kim, SH
- Kimbrough,S, 1996 Effective means for implementing wheelslip control without a
 Datla, K, groundspeed sensor, *Proc. 14th IAVSD Symp. on the Dynamics of Vehicles on Roads and Tracks, in Vehicle System Dynamics*, 25, 327-339.
- Kocijan, J, 1995 An Application of a Technique for the Tuning of
 Kosin, P Multiparameter Controllers, *Trans. Inst. MC*, 17, 2, 96-104.
 Karba, R.
- Kraft, LG, 1990 A Comparison Between CMAC Neural Network Control and
 Campagna, DP, Two Traditional Adaptive Control Systems, *IEEE Contr.Syst. Mag.*, April, 36-43.
- Kruse, R 1993 An application of Equality Relations to Idle Speed Control,
 Schröder, M. *Proc. 1st European Congress on Fuzzy and Intelligent Technologies*, 370-376, Aachen.
- Kuntze, H. B, 1985 Control Algorithms for Stiffening an Elastic Industrial Robot,
 Jacubasch, AHK, *IEEE Jnl. Robots and Automation*, RA-1, 2, June, 71-78.
- Kwon, DS 1994 Input filter shaping filter methods for the control of structurally
 Hwang, DH flexible long reach manipulators, *Proc IEEE Int. Conf on
 Robotics and Automation*, 3259-3264
 Babcock, SM
 Scott, M
 Burks, BL

- Kyura, N, 1996 *Mechatronics -an Industrial Perspective, IEEE/ASME Trans. on*
Oho, H *Mechatronics, 1, 1, 10-16.*
- Leu, MC, 1987 *Effect of Mechanical Compliance on Deflection of Robot*
Dukovski, V, *Manipulators, Annals CIRP, 36, 1, 305-308.*
Wang, KK.
- Lew, JY, 1996 *Vibrational Control of a Micro/Macro-Manipulator System,*
Trudnowski, DJ, *IEEE Jnl. Control Systems, 16, 1,26-32.*
- Lin, TC, 1993 *Design an Input Shaper to Reduce Operation-Induced Vibration,*
American Control Conf. 93, 2502-2505.
- Lightbody, G 1994 *A Neural network Based Auto-tuned Regulator*
Irwin, GW. *Control 94, IEE Conf Proc., 961-966.*
- Lin, LC, 1996 *Rigid Model Based Neural Network Control of Flexible Link*
Yih, TW, *Manipulators, IEEE Trans. Robotics and Automation, 12, 4,*
595-602, August.
- Lin, YJ, 1992 *Comprehensive Dynamic Modelling and Motion /Force Control*
Lee, TS, *of Flexible Manipulators, Mechatronics, 2, 129-148.*
- Loughlin, C, 1986 *Line, Edge and Contour Following with Eye-In-Hand Vision*
Morris, J. *System, in Robot Sensors Vol. 1, Ed A.Pugh.*
- Lu, E 1992 *Integrated lattice filter adaptive control system for time-varying*
Ni, J *CMM structural vibration control: part 1 theory and simulation,*
Wu, SM *ASME Annual Conf, 127-142.*

- Luo, RC, 1996 *Sensor Technologies and Microsensor Issues for Mechatronic Systems, IEEE/ASME Trans on Mechatronics, 1, 1, 39-50.*
- Luo, ZH, 1995 *Shear Force Feedback Control of Flexible Robot Arms,*
 Kitamura, S. *IEEE Trans. Robotics and Automation, 11, 5, 760-766.*
 Guo, BZ.
- McFarlane, DC 1989 *Robust Controller Design using Normalised Coprime Factor*
 Glover, K, *Plant Descriptions, Springer Verlag, Lecture Notes in Control and Information Sciences, Vol. 138*
- McFarlane, DC 1992 *A Loop Shaping Design Procedure using H_{∞} Synthesis., IEEE*
 Glover, K, *Trans on Automatic Control, 37,6, 759-769.*
- Mamdani, EH 1974 *Application of Fuzzy Algorithms for Control of Simple*
Dynamic Plant, Proc. IEE. Control & Science, 121, 12, 1585-
1588.
- Marino, R 1985 *On the Control of Robots with Elastic Joints, American Control*
 Nicosia, S, *Conf., 69-70.*
- Matsuno, F 1994 *Feedback control of decoupled bending and torsional vibrations*
 Murachi, T *of flexible beams, Jnl Robotic Systems, 11, 5, 341-353.*
 Sakawa, Y
- Mayes, RL 1993 *Experimental characterisation of a Flexible Two Link*
 Eisler, GR, *Manipulator arm, ASME DE-57, 109-113.*
- Matko, D 1992 *Simulation and Modelling of Continuous Systems, Prentice-*
 Karba, R *Hall.*
 Zupancic, B

- Mazumdar, SK 1995 Application of neural networks to anti-skid brake system design, *IEEE Int. Conf. on Neural Networks*, 2409-2414.
Cheng, CL
- Meashio, Y 1996 Tuneable Fuzzy Logic controller for a Hanging Pendulum, *Control 96 IEE Conf.Pub. 427*, 592-595.
Mahmood, A,
Singer, G.
- Meckl, P 1985 Active Damping in a Three Axis Robotic Manipulator, *Trans. ASME, Jnl. Vibration, Acoustics, Stress, and Reliability in Design*, 107, January, 38-46.
Seering, W,
- Medrano-Cerda, GA 1995 Adaptive position control of antagonistic pneumatic muscle actuators, *Proc IEEE/RSJ Intl Conf on Intelligent Robots and Systems*, 378-383.
Bowler, CJ
Caldwell, DG.
- Milford, RI 1996 Experimental On-Line Frequency Domain Identification and Adaptive Control of a Flexible Slewing Beam, *Trans. ASME Jnl. Dynamic Systems, Measurement and Control*, 118, 59-65, March.
Asokanthan, SF
- Miu, DK 1991 Physical Interpretation of Transfer Function Zeros for Simple Control Systems with Mechanical Flexibilities, *Trans. Jnl Dynamic Systems, Measurement and Control*, 113, 419-424, Sept.
- Narendra, KS 1990 Identification and Control of Dynamic Systems using Neural Networks, *IEEE Trans. Neural Networks*, 1, 1, 4-27, March.
Parthasarathy, K

- Nathan, PJ 1991
Singh, SN
Sliding Mode Control and Elastic Mode Stabilisation of a Robotic Arm with Flexible Links, *Trans ASME Jnl of Dynamic Systems, Measurement and Control*, 113, 669-675, Dec.
- Oh, S.Y 1995
Park, H.G,
Nam, S.H.
A Neural Network-Based Real-Time Robot Tracking Controller using Position Detectors, *Expert Systems*, 12, 2,115-122.
- Ohishi, K 1996
Miyazaki, T
Nakamura, Y
High Performance Ultra-Low Speed Servo System based on Doubly Coprime Factorisation and, Instantaneous Speed Observer, *IEEE/ASME Trans on Mechatronics*, 1, 1, 89-99.
- Olson, WW 1996
Milacic, D,
Development of anti-lock braking traction and control systems of advanced technology demonstrator II using DADS simulation code *Int. Jnl. of Vehicle Design*, 17,3, 295-317.
- Orrock, JE 1986
Garfunkel, JH,
Owen, BA.
An Integrated Vision/Range Sensor, in Robot Sensors Vol. 1 Ed A. Pugh.
- Parks, TR 1991
Pak, HA,
Effect of Payload on the Dynamics of a Flexible Manipulator-modelling for Control, *Trans. of ASME, Jnl. of Dynamic Systems Measurement and Control*, 113, 409-417.
- Phelan, RM, 1981
Subvariable Control, *Cornell University*, Private Communication.
- Phelan, RM, 1983
Chen, L.
Subvariable Control, *Cornell University report MSD-84-02*.
- Phelan, R.M,1986
PDF Control Systems With Time Delay, *Cornell University report MSD-86-03*.

- Plump, JM, 1987 Non-linear Control of a Distributed System: Simulation and
Hubbard, JE.Jr, Experimental Results, *Trans. ASME Jnl. Dynamic Systems*
Bailey, T, *Measurement and Control* 109, 133-139, June.
- Popovic, MR 1995 Novel controller using fuzzy logic interpolation for accurate
Gorinevsky, DM, positioning under conditions of non-linear low-velocity friction,
Goldenberg, AA. *Proc. 34th IEEE Conf. on Decision and Control, part 1,*
 262-272.
- Purdy, DJ 1994 High precision tip angle control of a flexible beam with drive
 line dynamics, *Control 94 IEE Conf Proc* 389, 565-570.
- Purucker, MC 1996 Design of a sliding linear investigative platform for analysing
Robinson, CJ. lower limb stability, *Proc. 15th Southern Biomedical*
 Engineering Conf., IEEE, 89-92.
- Readman, MC 1994 *Flexible Joint Robots*, CRC press.
- Rees-Jones, J 1983 Vibration due to Motion Discontinuities in Hydraulically
 Actuated Robots., *Robotica, 1,211-215.*
- Safonov, MG 1977 Gain and Phase Margin for Multiloop LQG Regulators, *Trans*
Athans,M, *IEEE on Automatic Control, AC-22, 2, April.*
- Schmidt, G 1996 Applying Fuzzy Tuned PI Control to a Non-Linear Hydraulic
Yang, TC, Positioning System, *Control 96, IEE Conf. Pub. 427, 603-605.*
Wu, Q.H.
- Sharan, AM 1992 Efficient Methods for Solving Dynamic Problems of Flexible
Jain, J, Manipulators, *Trans. of ASME, Jnl. of Dynamic Systems,*
Kalra, P. *Measurement, and Control, 114, 79-87.*

- Shimazu, T 1995 Development of a hexahedron rubber actuator, *Proc IEEE Intl Conf on Robotics and Automation, Pt 3*, 2619-2624.
- Hayakuwa, Y
Kawamura, S.
- Shiraishi, M 1988 Suppression of Machine-Tool Chatter by State Feedback Control, *Annals of CIRP*, 37, 1, 369-372.
- Kume, E
- Siciliano, B 1992 Output Feedback Two-Time Scale Control of Multilink, Flexible Arms, *Trans. ASME Jnl. Dynamic Systems, Measurement and Control*, 114, 71-77, March.
- Prasad, JVR,
Calise, AJ,
- Sidman, MD 1986 Adaptive Control of a Flexible Structure, *Proc. IFAC Conf. Adaptive Systems in Control and Signal Processing*, 277-282.
- Franklin, GF.
- Singh, SN 1985 Decomposition and State Variable Feedback Control of Elastic Robotic Systems, *American Control Conf.*, 375-382.
- Schy, AA.
- Song, G 1996 New approach to robust position/force control of flexible joint robot manipulators, *Jnl. Robotic Systems*, 13, 7, 429-444.
- Cai, L.
- Tang, J 1995 Variable structure control of a pneumatic actuator, *Jnl. of Dynamic Systems, Measurement and Control, Trans ASME*, 117, 1, 88-92.
- Walker, G.
- Tillett, ND 1993 Flexible pneumatic actuators for horticultural robots- a feasibility study, *Mechatronics*, 3,3, 315-328.
- Tilley, SW 1986 End Point Force-Control of a Very Flexible Manipulator With a Fast End-Effector, *ASME DSC-Vol. 3*, 1-11.
- Cannon, RH.Jr.
Kraft, R.

- Wang, D, 1991 Control of Manipulators with a Single Flexible Link-Part 1:
Vidyasagar, M, Feedback Linearisation, *Trans. ASME Jnl Dynamic
Systems, Measurement and Control*, 113, 655-661, Dec.
- Wang, D, 1991 Control of Manipulators With a Single Flexible Link-Part 2:
Vidyasagar, M, Observer-Controller Stabilisation, *Trans. ASME Jnl.
Dynamic Systems, Measurement and Control*, 113, 662-667,
Dec.
- Wang, J 1994 An Experimental Investigation of the Dynamic Performance of
Jordan, JR. Fuzzy Logic Control, *Trans. Inst. MC.*, 16, 3, 142-148.
- Wang, FS 1995 Multiple-loop PID Controller Tuning by Goal Attainment
Wu, TY. Trade-off Method, *Trans. Inst. MC.*, 17, 1, 27-34.
- Wang, Q 1994 A Novel Neural Adaptive Controller for Robots
Broome, DR *Control 94, Proc IEE Conf 389, 486-491.*
- Warnecke, HJ 1985 Application of The Experimental Modal-Analysis in the
Schraft, RD, Performance Testing Procedure of Industrial Robots.,
Wanner, MC. *Robot Technology and Applications, Proc. 1st Robotics
Europe Conference, Brussels, June 27-28,1984,
Springer Verlag.*
- Warwick, K 1994 Neural Networks for Control:Counter Arguments
Control 94, IEE Conf Proc 389, 95-99.
- Whitehead, HG1986 *A Low Resolution Vision Sensor*, in Robot Sensors
Mitchell, I, Vol 1 Ed A. Pugh
Mellor, PV.

- Wie, B 1988 **Active Vibration Control Synthesis for the Control of Flexible Structures Mast Flight System, *Jnl. Guidance, 11, 3, 271-277, May-June.***
- Xi, F 1994 **Determination of the natural frequencies of flexible joint manipulators, *Proc of the 5th World Conf on Robotics Research, Unpublished.***
- Fenton, RG
- Yoshkawa, T 1996 **Hybrid Position/Force Control of Flexible Macro/Micro Manipulator Systems, *IEEE Trans. Robotics and Automation, 12, 4, 633-640, August.***
- Harada, K
- Matsumoto, A.
- Youcef-Toumi, T 1996 **Modeling, Design, and Control Integration: a Necessary Step in Mechatronics, *IEEE/ASME Trans on Mechatronics, 1, 1, 29-39, March.***
- Zadeh, LA 1965 **Fuzzy Sets, *Information and Control, 8, 338-353.***
- Zaki, A 1994 **Experiments on the Modelling and Vibration Control of a Three-Degree Of Freedom Manipulator with Flexible Links, *Trans. Cam. Soc. Mech. Eng, 18, 1, 47-64.***
- Elmaraghy, WH.